



FORWARD

CONTENTS

HOW TO USE THIS MANUAL

MECHANISM ILLUSTRATIONS

Atena RS-21



SERVICE MANUAL



This service manual contains the technical data of each component inspection and repair for the SANYANG ATTILA RS-21 EFi 150 motorcycle. The manual is shown with illustrations and focused on “Service Procedures”, “Operation Key Points”, and “Inspection Adjustment” so that provides technician with service guidelines.

If the style and construction of the motorcycle are different from that of the photos, pictures shown in this manual, the actual vehicle shall prevail. Specifications are subject to change without notice.

This manual that contains all data, illustration, indication and specifications is based on current production information. SANYANG reserves the right to make changes at any time without notice and without incurring any obligation whatever. No part of this manual can be duplicated by any means without written permission of SANYANG.

**Service Department
SANYANG Industry Co., LTD.**

How to Use This Manual



This service manual describes basic information of different system parts and system inspection & service for SANYANG ATTILA RS-21 EFi 150 motorcycles. In addition, please refer to the manual contents in detailed for the model you serviced in inspection and adjustment.

The first chapter covers general information and trouble diagnosis.

The second chapter covers service maintenance and special service tools information.

The third to the eleventh chapters cover engine, fuel injection and driving systems.

The twelfth to fifteenth chapters are contained the parts set of assembly body.

The sixteenth chapter is electrical equipment.

The seventh chapter is exhaust emission control system.

The eighteenth chapter is for wiring diagram

Please see index of content for quick having the special parts and system information.

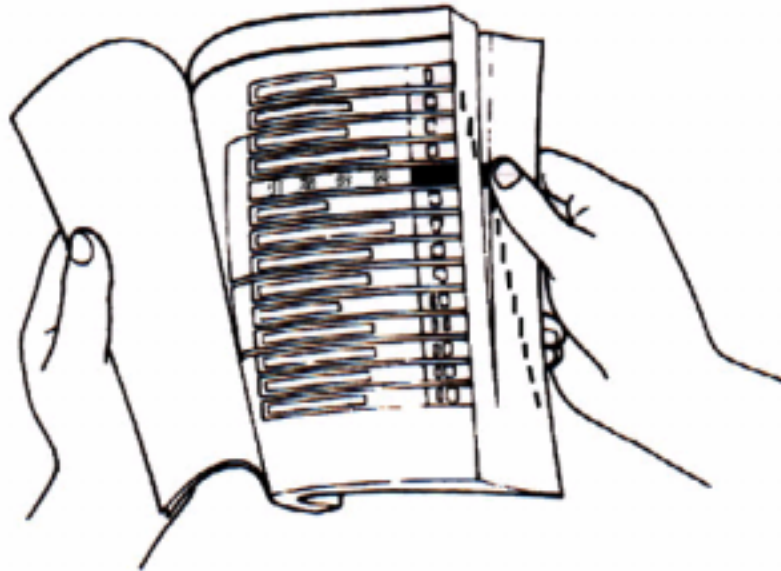

Page	Content	Index
1-1 ~ 1-16	General Information / Trouble Diagnosis	1
2-1 ~ 2-16	Service Maintenance Information	2
3-1 ~ 3-8	Lubrication System	3
4-1 ~ 4-38	Fuel System	4
5-1 ~ 5-10	Engine Removal	5
6-1 ~ 6-16	Cylinder Head / Valve	6
7-1 ~ 7-8	Cylinder / Piston	7
8-1 ~ 8-14	“V” Type Belt Driving System / Foot-Starter	8
9-1 ~ 9-6	Final Driving Mechanism	9
10-1 ~ 10-10	Alternator / Starting Clutch	10
11-1 ~ 11-6	Crankcase/Crankshaft	11
12-1 ~ 12-14	Body Cover	12
13-1 ~ 13-10	Brake System	13
14-1 ~ 14-8	Steering/Front Wheel/Suspension	14
15-1 ~ 15-6	Rear Wheel/Suspension	15
16-1 ~ 16-18	Electrical Equipment	16
17-1 ~ 17-8	Exhaust Emission Control System	17
18-1 ~ 18-2	Electrical Diagram	18



Model illustration

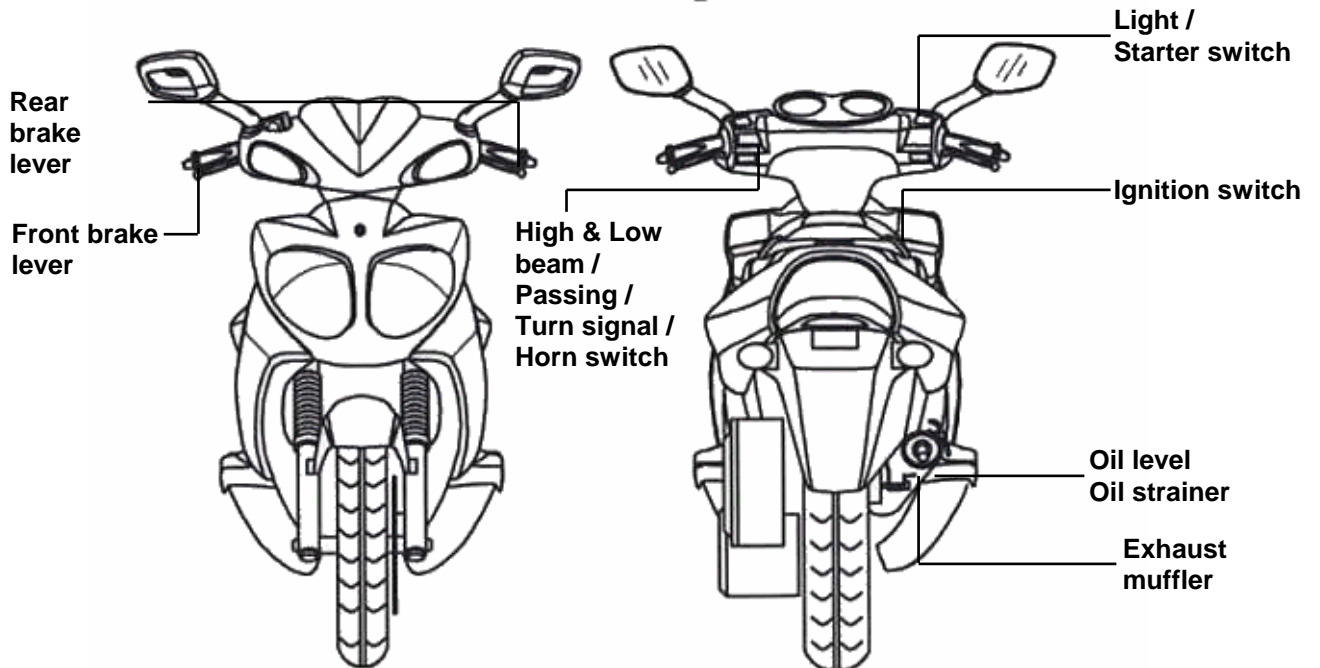
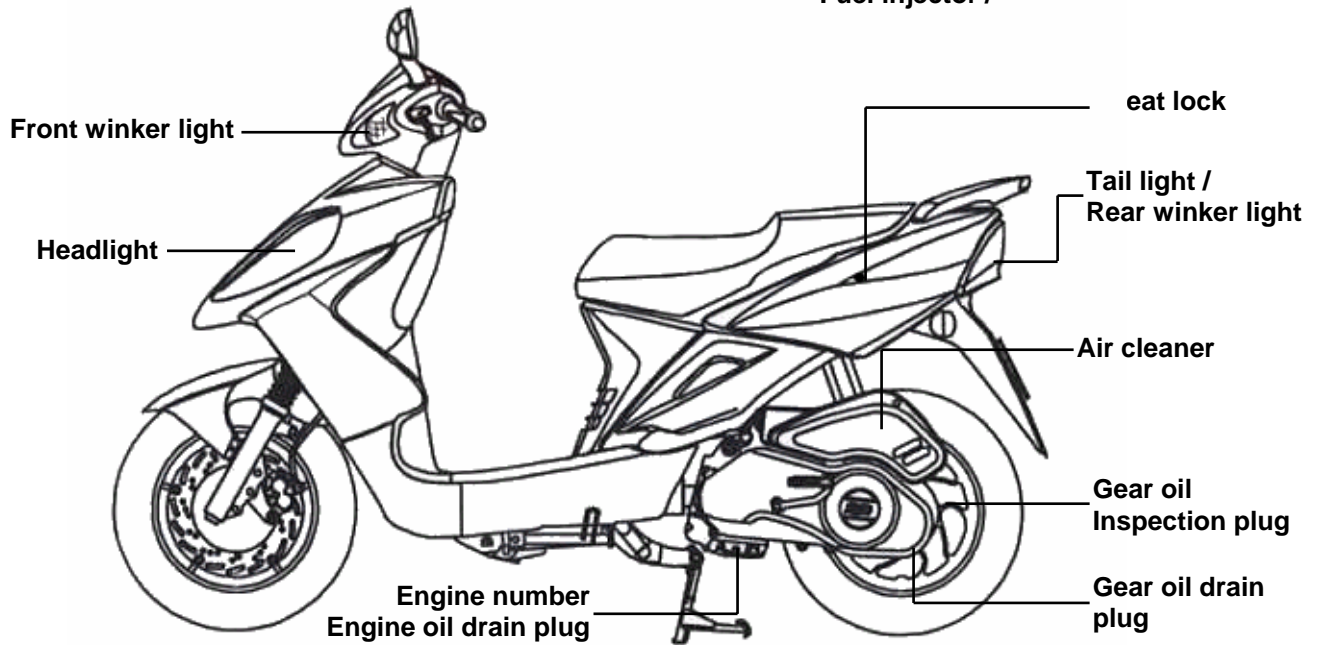
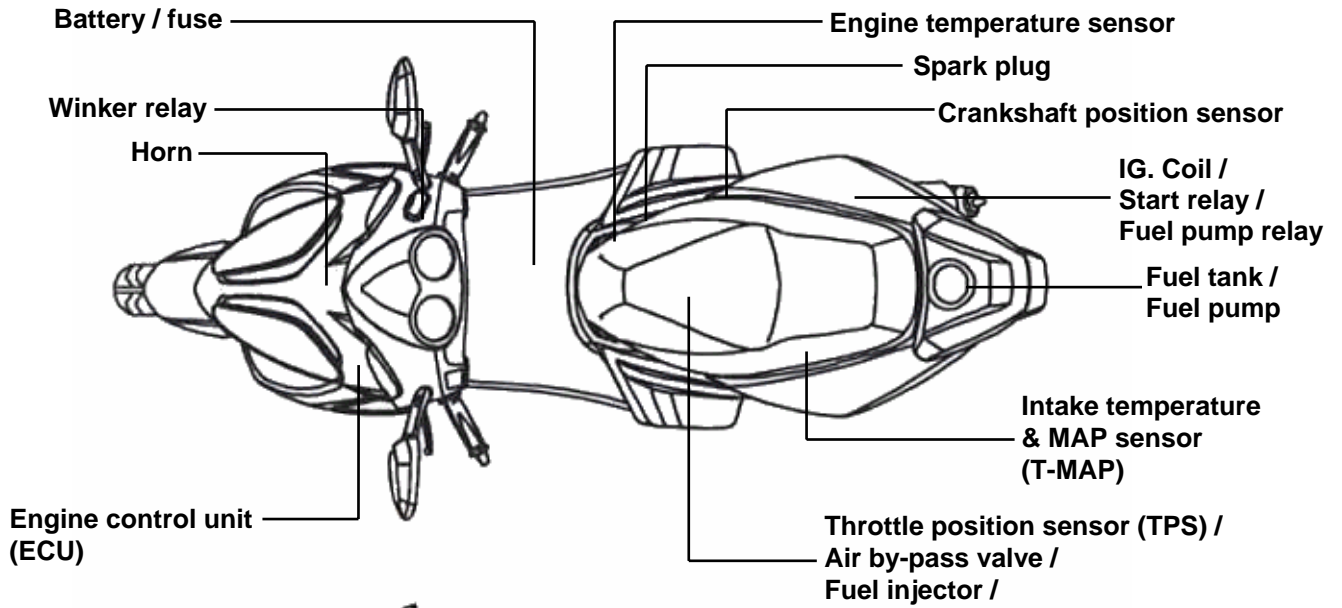

Symbols And Marks..... 1-1	Torque Values (Frame) 1-11
General safety 1-2	Standard Torque Values for Reference..... 1-11
Service Precautions..... 1-3	Troubles Diagnosis..... 1-12
Specifications..... 1-9	Parts To Be Greased..... 1-16
Torque Values (Engine)..... 1-10	

Symbols And Marks

Symbols and marks are used in this manual to indicate what and where the special service are needed, in case supplemental information is procedures needed for these symbols and marks, explanations will be added to the text instead of using the symbols or marks.

	Warning	Means that serious injury or even death may result if procedures are not followed.
	Caution	Means that equipment damages may result if procedures are not followed.
	Engine oil	Limits to use SAE 10W-30 API SG class oil. Warranty will not cover the damage that caused by not apply with the limited engine oil. (Recommended oil: KING MATE G-3 oil)
	Grease	King Mate G-3 is recommended. (KING MATE G-3)
	Gear oil	King Mate gear oil (SYM HYPOID GEAR OIL) is recommended. (SAE 85W-140)
	Locking sealant	Apply sealant, medium strength sealant should be used unless otherwise specified.
	Oil seal	Apply with lubricant.
	Renew	Replace with a new part before installation.
	Brake fluid	Use recommended brake fluid "DOT3" or "WELLRUN" brake fluid.
	Special tools	Special service tools.
	correct	Meaning correct installation.
	wrong	Meaning wrong installation.
	Indication	Indication of components.
	directions	Indicates position and operation directions.
		Components assembly directions each other.
		Indicates where the bolt installation direction, --- means that bolt cross through the component (invisibility).

1. General Information/Trouble Diagnosis

General safety

Carbon monoxide

If you must run your engine, ensure the place is well ventilated. Never run your engine in a closed area. Run your engine in an open area, if you have to run your engine in a closed area, be sure to use an extractor.

 **Caution**

Exhaust contains toxic gas which may cause one to lose consciousness and even result in death.

Gasoline

Gasoline is a low ignition point and explosive material. Work in a well-ventilated place, no flame or spark should be allowed in the work place or where gasoline is being stored.

 **Caution**

Gasoline is highly flammable, and may explode under some conditions, keep it away from children.

Used engine oil

 **Caution**

Prolonged contact with used engine oil (or transmission oil) may cause skin cancer although it might not be verdict. We recommend that you wash your hands with soap and water right after contacting. Keep the used oil beyond reach of children.

Hot components

 **Caution**

Components of the engine and exhaust system can become extremely hot after engine running. They remain very hot even after the engine has been stopped for some time. When performing service work on these parts, wear insulated gloves and wait until cooling off.

Battery

 **Caution**

- Battery emits explosive gases; flame is strictly prohibited. Keep the place well ventilated when charging the battery.
- Battery contains sulfuric acid (electrolyte) which can cause serious burns so be careful do not be spray on your eyes or skin. If you get battery acid on your skin, flush it off immediately with water. If you get battery acid in your eyes, flush it off immediately with water, then go to hospital to see an ophthalmologist.
- If you swallow it by mistake, drink a lot of water or milk, and take some laxative such as castor oil or vegetable oil, and then go to see a doctor.
- Keep electrolyte beyond reach of children.

Brake shoe

Do not use an compressed air or a dry brush to clean components of the brake system, use a vacuum cleaner or the equivalent to avoid asbestos dust flying.

 **Caution**

Inhaling asbestos dust may cause disorders and cancer of the breathing system.

Brake fluid

 **Caution**

Spilling brake fluid on painted, plastic, or rubber parts may cause damage to the parts. Place a clean towel on the above-mentioned parts for protection when servicing the brake system. Keep brake fluid beyond reach of children.

Service Precautions

Always use with SANYANG genuine parts and recommended oils. Using non-designed parts for SANYANG motorcycle may damage the motorcycle.



Special tools are designed for remove and install of components without damaging the parts being worked on. Using wrong tools may result in parts damaged.

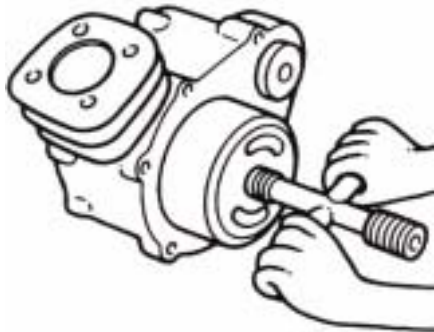

When servicing this motorcycle, use only metric tools. Metric bolts, nuts, and screws are not interchangeable with the English system, using wrong tools and fasteners may damage this vehicle.

Clean the outside of the parts or the cover before removing it from the motorcycle. Otherwise, dirt and deposit accumulated on the part's surface may fall into the engine, chassis, or brake system to cause a damage. Wash and clean parts with high ignition point solvent, and blow dry with compressed air. Pay special attention to O-rings or oil seals because most cleaning agents have an adverse effect on them.

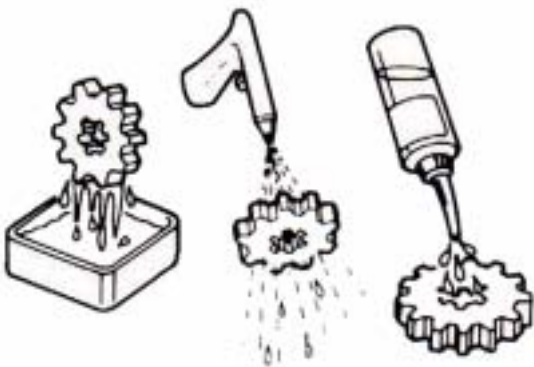

Never bend or twist a control cable to prevent stiff control and premature worn out.



Rubber parts may become deteriorated when old, and prone to be damaged by solvent and oil. Check these parts before installation to make sure that they are in good condition, replace if necessary.

When loosening a component which has different sized fasteners, operate with a diagonal pattern and work from inside out. Loosen the small fasteners first. If the bigger ones are loosen first, small fasteners may receive too much stress.

Store complex components such as transmission parts in the proper assemble order and tie them together with a wire for ease of installation later.

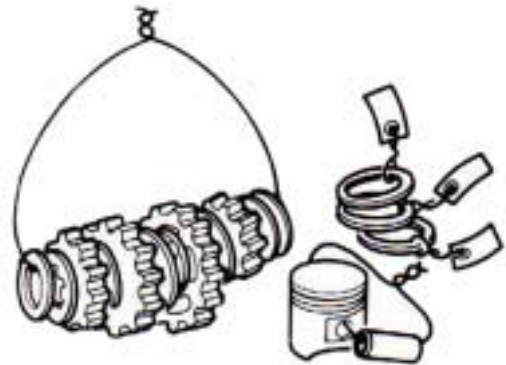

Note the reassemble position of the important components before disassembling them to ensure they will be reassembled in correct dimensions (depth, distance or position). Components not to be reused should be replaced when disassembled including gaskets metal seal rings, O-rings, oil seals, snap rings, and split pins.



1. General Information/Trouble Diagnosis

The length of bolts and screws for assemblies, cover plates or boxes is different from one another, be sure they are correctly installed. In case of confusion, Insert the bolt into the hole to compare its length with other bolts, if its length out side the hole is the same with other bolts, it is a correct bolt. Bolts for the same assembly should have the same length.

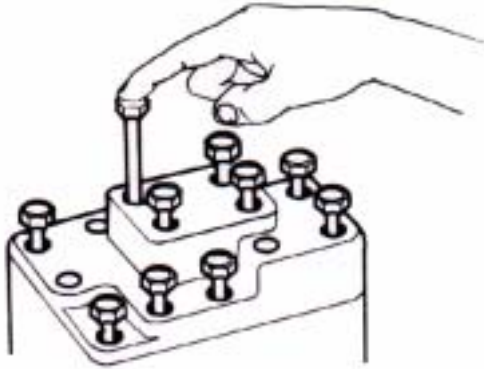

Tighten assemblies with different dimension fasteners as follows: Tighten all the fasteners with fingers, then tighten the big ones with special tool first diagonally from inside toward outside, important components should be tightened 2 to 3 times with appropriate increments to avoid warp unless otherwise indicated. Bolts and fasteners should be kept clean and dry. Do not apply oil to the threads.



When oil seal is installed, fill the groove with grease, install the oil seal with the name of the manufacturer facing outside, check the shaft on which the oil seal is to be installed for smoothness and for burrs that may damage the oil seal.

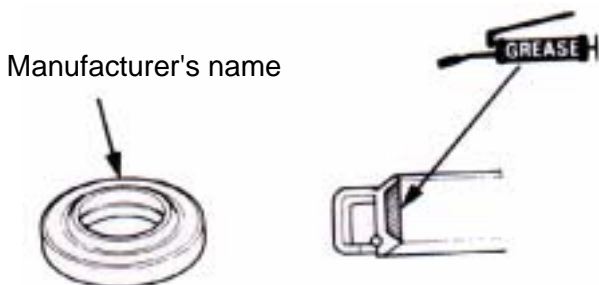

Remove residues of the old gasket or sealant before reinstallation, grind with a grindstone if the contact surface has any damage.



The ends of rubber hoses (for fuel, vacuum, or coolant) should be pushed as far as they can go to their connections so that there is enough room below the enlarged ends for tightening the clamps.



Rubber and plastic boots should be properly reinstalled to the original correct positions as designed.

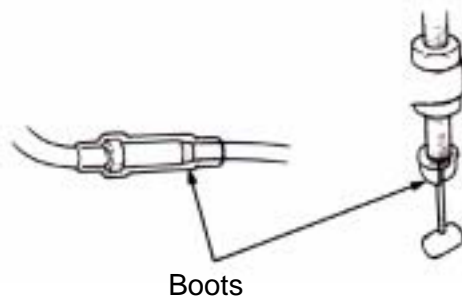

The tool should be pressed against two (inner and outer) bearing races when removing a ball bearing. Damage may result if the tool is pressed against only one race (either inner race or outer race). In this case, the bearing should be replaced. To avoid damaging the bearing, use equal force on both races.

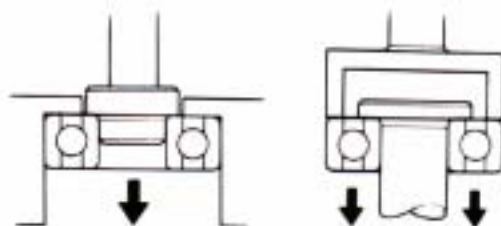

Both of these examples can result in bearing damage.

1. General Information/Trouble Diagnosis

Lubricate the rotation face with specified lubricant on the lubrication points before assembling.

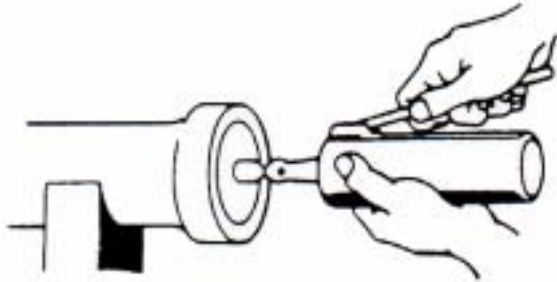

Check if positions and operation for installed parts is in correct and properly.



Make sure service safety each other when conducting by two persons.



Note that do not let parts fall down.



Before battery removal operation, it has to remove the battery negative (-) cable firstly. Notre tools like open-end wrench do not contact with body to prevent from circuit short and create spark.

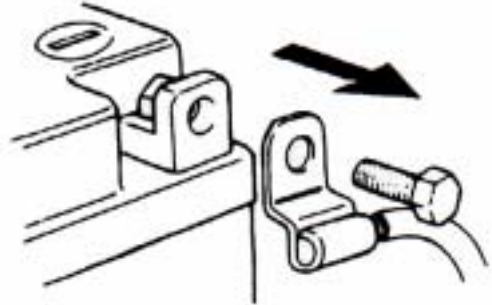

After service completed, make sure all connection points is secured. Battery positive (+) cable should be connected firstly. And the two posts of battery have to be greased after connected the cables.



Make sure that the battery post caps are located in properly after the battery posts had been serviced.

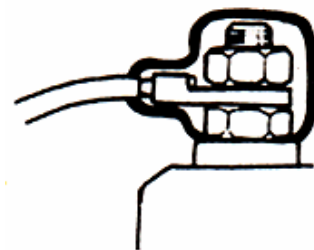

If fuse burned, it has to find out the cause and solved it. And then replace with specified capacity fuse.

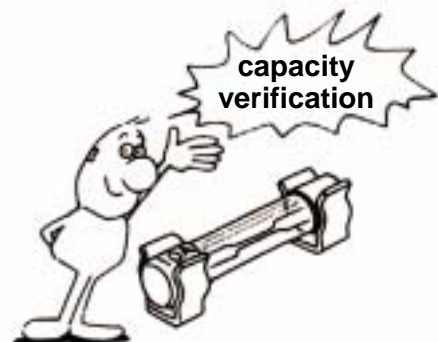

1. General Information/Trouble Diagnosis

When separating a connector, its locker has to be unlocked firstly. Then, conduct the service operation.

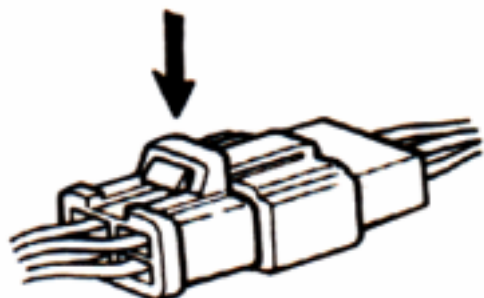

Do not pull the wires as removing a connector or wires. Hold the connector body.



Make sure if the connector pins are bent, extruded or loosen.

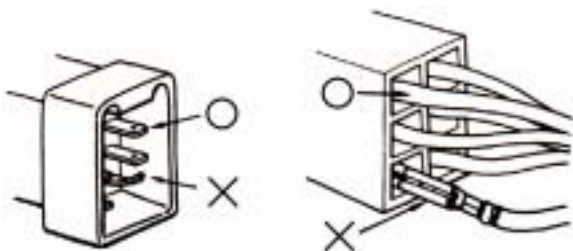

Insert the connector completely. If there are two lockers on two connector sides, make sure the lockers are locked in properly. Check if any wire loose.

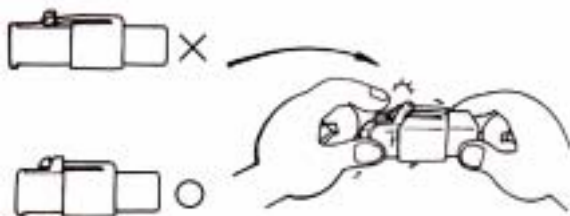

Check if the connector is covered by the twin connector boot completely and secured properly.

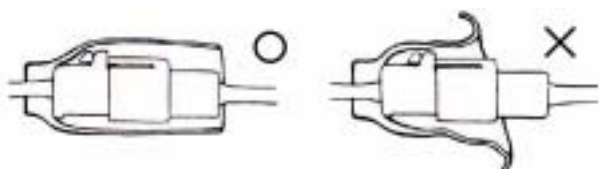

Before terminal connection, check if the boot is crack or the terminal is loose.



Insert the terminal completely. Check if the terminal is covered by the boot. Do not let boot open facing up.



Secure wires and wire harnesses to the frame with respective wire bands at the designated locations. Tighten the bands so that only the insulated surfaces contact the wires or wire harnesses.

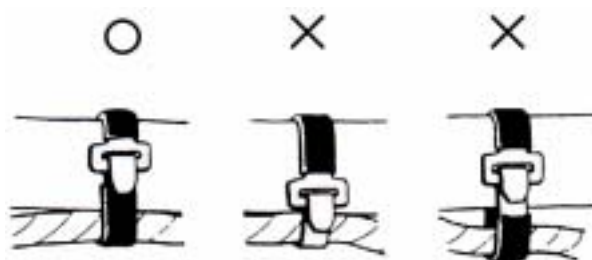

Wire band and wire harness have to be clamped secured properly.

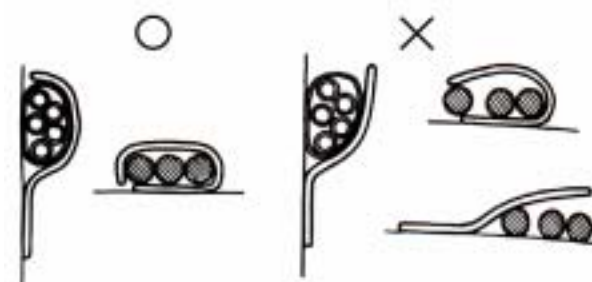

Do not squeeze wires against the weld or its clamp.



1. General Information/Trouble Diagnosis

Do not let the wire harness contact with rotating, moving or vibrating components as routing the harness.

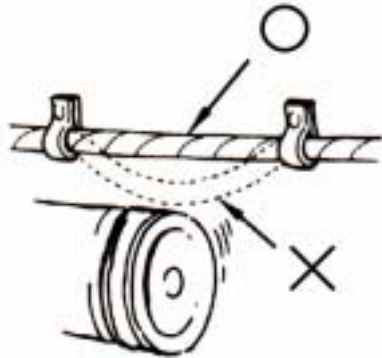

Keep wire harnesses far away from the hot parts.

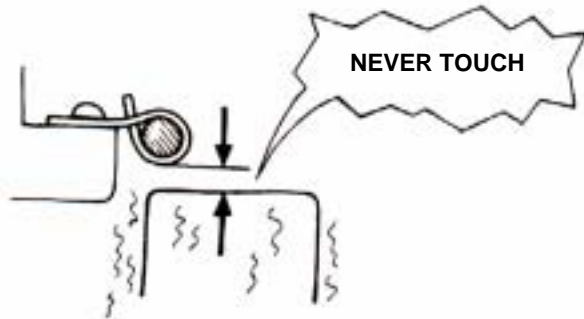

- Route wire harnesses to avoid sharp edges or corners and also avoid the projected ends of bolts and screws.

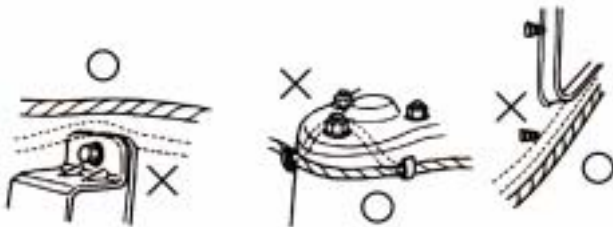

Route harnesses so that they neither pull too tight nor have excessive slack.

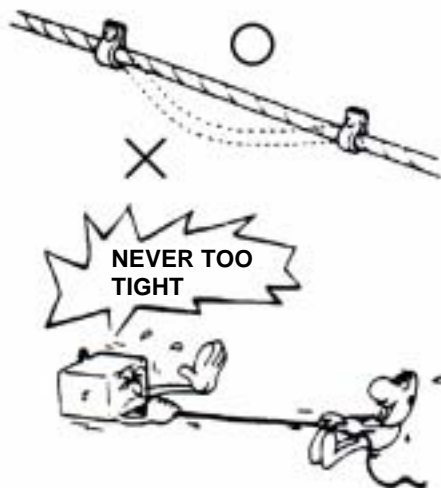

Protect wires or wire harnesses with electrical tape or tube if they contact a sharp edge or corner. Thoroughly clean the surface where tape is to be applied.

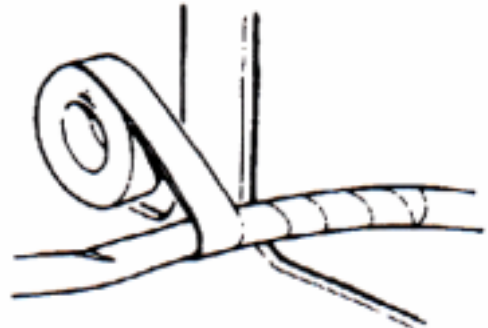

Secure the rubber boot firmly as applying it on wire harness.

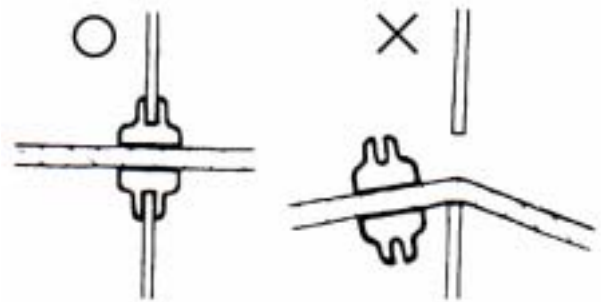

Never use wires or harnesses which insulation has been broken. Wrap electrical tape around the damaged parts or replace them.

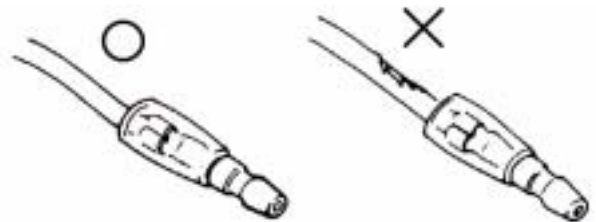

Never clamp or squeeze the wire harness as installing other components.



1. General Information/Trouble Diagnosis

Do not let the wire harness been twisted as installation.

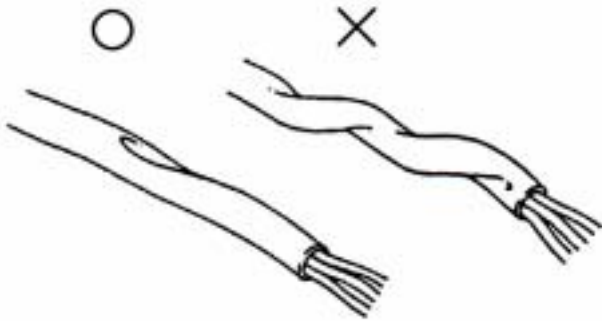

With sand paper to clean rust on connector pins/terminals if found. And then conduct connection operation later.



- Wire harnesses routed along the handlebar should not be pulled too tight or have excessive slack, be rubbed against or interfere with adjacent or surrounding parts in all steering positions.

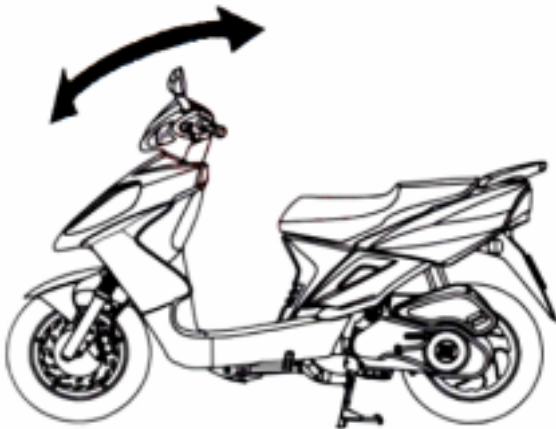

- Before operating a test instrument, operator should read the operation manual of the instrument. And then, conduct test in accordance with the instruction.

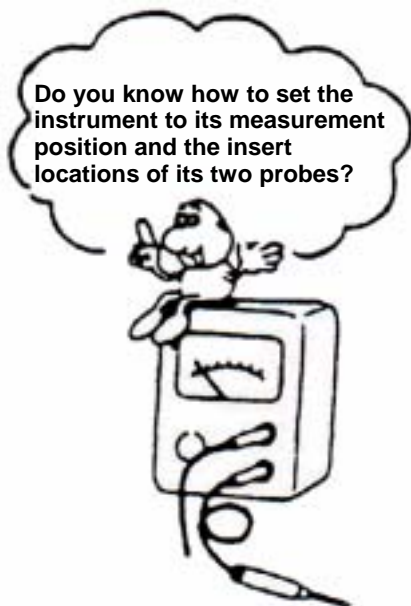



1. General Information/Trouble Diagnosis

Specifications

Maker		SANYANG		MODEL		HE15W	
DIMENSION	Overall Length		1933 mm		Suspension System	Front	TELESCOPE
	Overall Width		700 mm			Rear	UNIT SWING
	Overall Height		1160 mm		Tire Specifications	Front	100 / 90-12 (T/L)
	Wheel Base		1335 mm			Rear	130 / 70 -12 (T/L)
WEIGHT	Curb Weight	Front	48 kg		Brake System	Front	DISK (ø 273 mm)
		Rear	75 kg			Rear	DRUM (ø 200 mm)
		Total	123 kg				
	Passengers/Weight		Two /110 kg		PERFORMANCE	Max. Speed	100 km/hr Above
	Total Weight	Front	78 kg			Climb Ability	28° Below
		Rear	155 kg		Reduction	Primary Reduction	BELT
Total		233 kg		Secondary Reduction		GEAR	
Type		4-STROKE ENGINE		Clutch	Centrifugal, dry type		
Installation and arrangement		Vertical, below center, incline 80°			Transmission	C.V.T.	
Fuel Used		Unleaded		Speedometer		0 ~ 140 km/hr	
Cycle/Cooling		4-stroke/forced air cooled		Horn		70~90 dB/A	
ENGINE	Cylinder	Bore	57.4 mm		Muffler		Expansion & Pulse Type
		Stroke	57.8 mm		Exhaust Pipe Position and Direction		Right side, and Backward
		Number/Arrangement	Single Cylinder		Lubrication System		Separated-lubrication
Displacement		149.5 cc		Exhaust Concentration	Solid Particulate	-	
Compression Ratio		9.6 : 1			CO	Below 4 %	
Max. HP		12.4 ps / 8500 rpm			HC	Below 2000 ppm	
Max. Torque		1.15 kg-m / 6500 rpm		E.E.C.		YES	
Ignition		C.D.I.		P.C.V.		YES	
Starting System		Power & Foot		Catalytic reaction control system		NO	

1. General Information/Trouble Diagnosis

Torque Values (Engine)

Item	Q'ty	Thread Dia. (mm)	Torque Value(Kg-m)	Remarks
Cylinder head bolts	4	6	1.0~1.4	
Cylinder head nuts	4	8	2.0~2.4	
Cylinder/cylinder head two-ends bolts	4	8	0.7~1.1	Tighten to crankcase
Cylinder head left bolts	4	6	1.0~1.4	
Valve adjustment fixing nuts	4	5	0.7~1.1	Apply oil to thread
Cylinder head left cover bolts	2	6	1.0~1.4	
Spark plug	1	10	1.0~1.2	
Carburetor heat protector connecting nuts	2	6	0.7~1.1	
Engine oil draining plug	1	12	3.5~4.5	
Engine oil strainer cap	1	30	1.0~2.0	
Gear oil draining plug	1	8	0.8~1.2	
Gear oil filling bolt	1	10	1.0~1.4	
Oil pump screws	3	3	0.1~0.3	
Engine left side cover bolts	8	6	1.0~1.5	Rubber washer attached
Camshaft chain tensioner bolt	1	6	0.35~0.5	Hex socket bolt
Camshaft chain adjuster bolts	1	6	0.8~1.2	
Clutch driving plate nut	1	28	5.0~6.0	
Clutch outer bracket nut	1	12	5.0~6.0	
Driving disk nut	1	12	5.0~6.0	
Flywheel nut	1	12	5.0~6.0	
One-way clutch tighten bolts	3	6	1.0~1.4	Apply locking sealant
One-way clutch nut	1	22	9.0~10.0	Apply oil to thread
Crankcase bolts/right crank cover bolt	12	8	1.5~2.0	
Gear box cap bolts	7	8	2.0~2.4	
Exhaust pipe bolts	2	8	3.0~3.6	
Exhaust pipe connection nut	2	7	0.5~1.0	

Torque Values (Frame)

Item	Q'ty	Thread Dia. (mm)	Torque Value(Kg-m)	Remarks
Mounting bolt for steering handlebar	1	10	4.0~5.0	
Mounting nut for steering rod	1	25.4	1.0~2.0	
Cone seat for steering rod	1	25.4	0.2~0.3	
Front wheel shaft nut	1	12	5.0~7.0	
Rear wheel shaft nut	1	16	11.0~13.0	
Wheel hub/rim mounting nuts	1	5	0.15~0.3	
Speedometer cable locking screw	4	8	2.4~3.0	
Front shock absorber mounting bolts	1	10	3.5~4.5	
Rear shock absorber upper connection bolt	1	8	2.4~3.0	
Rear shock absorber upper connection bolt	4	6	1.0~1.4	
Brake lever bolts	2	4	0.1~0.2	
Front brake hose bolts	2	6	1.0~1.4	
Front brake air-bleeding valve	2	10	3.0~4.0	
Front brake disc mounting bolts	1	6	0.7~1.1	
Front brake clipper mounting bolts	4	8	4.0~4.5	
Drum brake arm bolts (front/rear)	2	8	2.9~3.5	
Engine suspension bracket bolts	2	10	4.5~5.5	On frame side
Engine connection bolt	1	12	5.0~7.0	On engine side
Main standard nut	1	10	3.5~4.5	
Foot-starting lever bolt	1	6	1.6~1.8	
Air cleaner bolts	2	6	1.0~1.4	

The torque values listed in above table are for more important tighten torque values. Please see standard values for not listed in the table.

Standard Torque Values for Reference

Type	Tighten Torque	Type	Tighten Torque
5mm bolt、nut	0.45~0.60 kgf-m	3mm screw	0.05~0.08 kgf-m
6mm bolt、nut	0.80~1.20 kgf-m	4mm screw	0.10~0.15 kgf-m
8mm bolt、nut	1.80~2.50 kgf-m	5mm screw	0.35~0.50 kgf-m
10mm bolt、nut	3.00~4.00 kgf-m	6mm screw、SH nut	0.70~1.10 kgf-m
12mm bolt、nut	5.00~6.00 kgf-m	6mm bolt、nut	1.00~1.40 kgf-m
		8mm bolt、nut	2.40~3.00 kgf-m
		10mm bolt、nut	3.50~4.50 kgf-m



1. General Information/Trouble Diagnosis

Troubles Diagnosis

A. Engine hard to start or can not be started

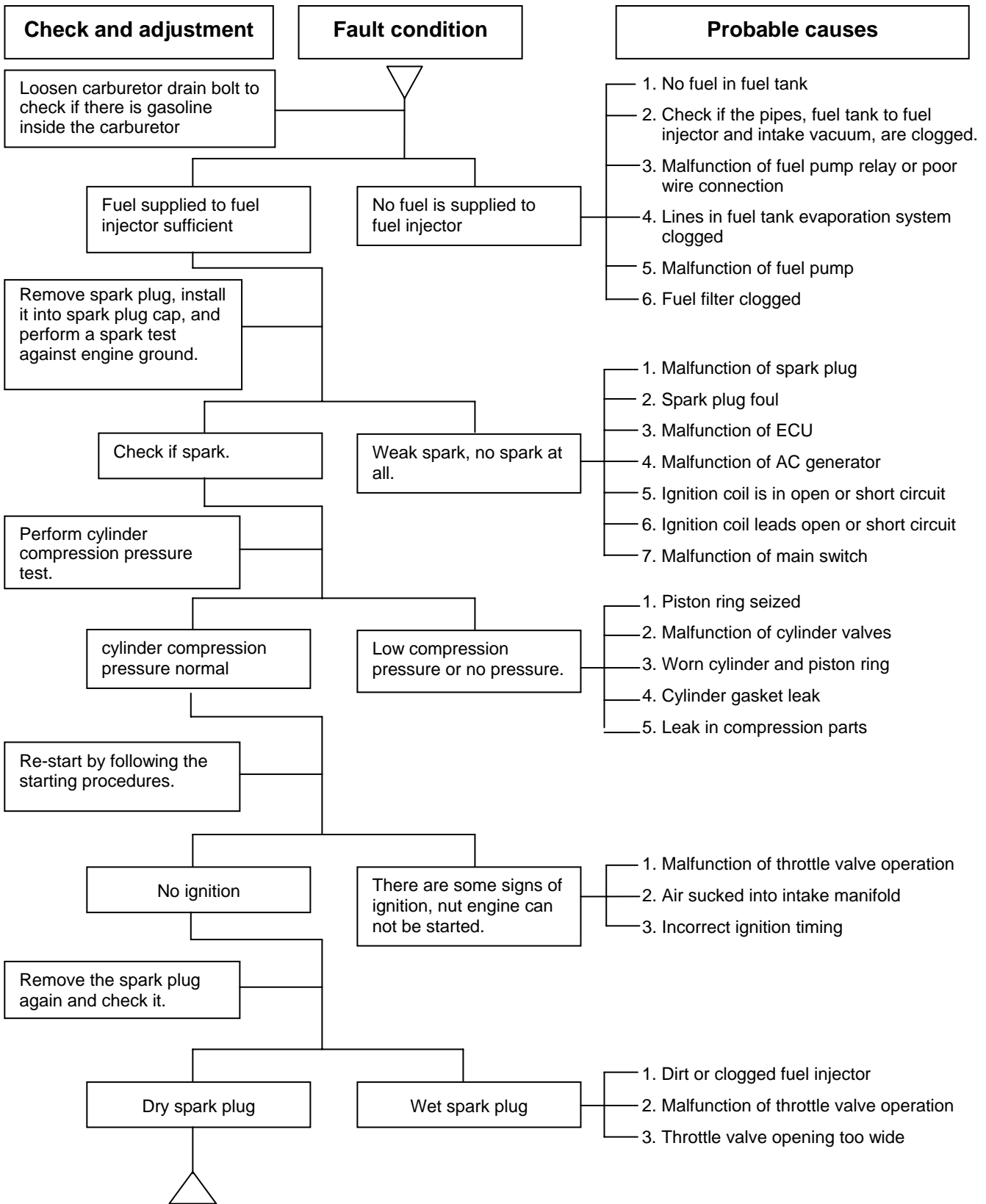



1. General Information/Trouble Diagnosis

B. Engine run sluggish (Speed does not pick up, lack of power)

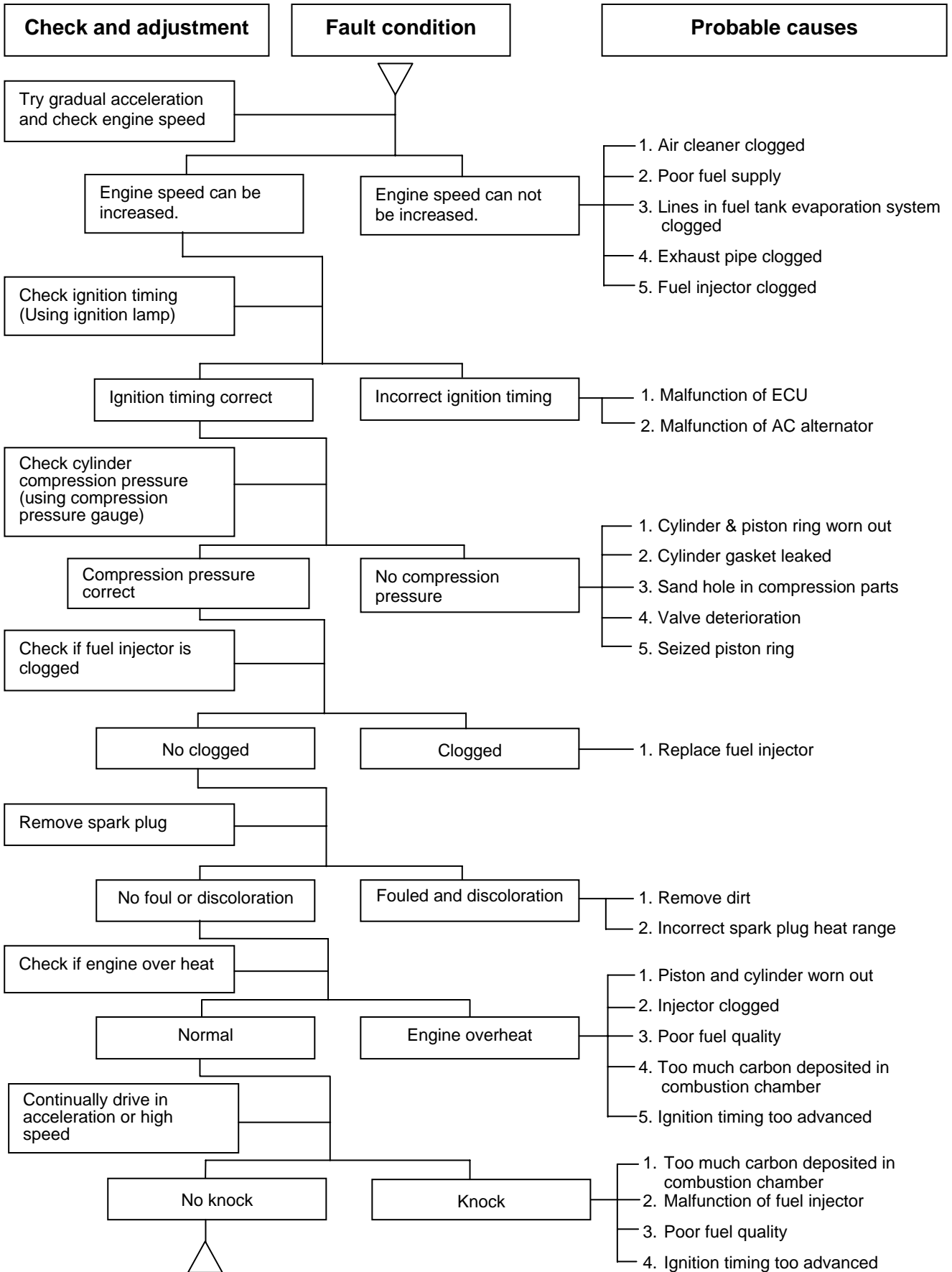

1. General Information/Trouble Diagnosis

C. Engine runs sluggish (especially in low speed and idling)

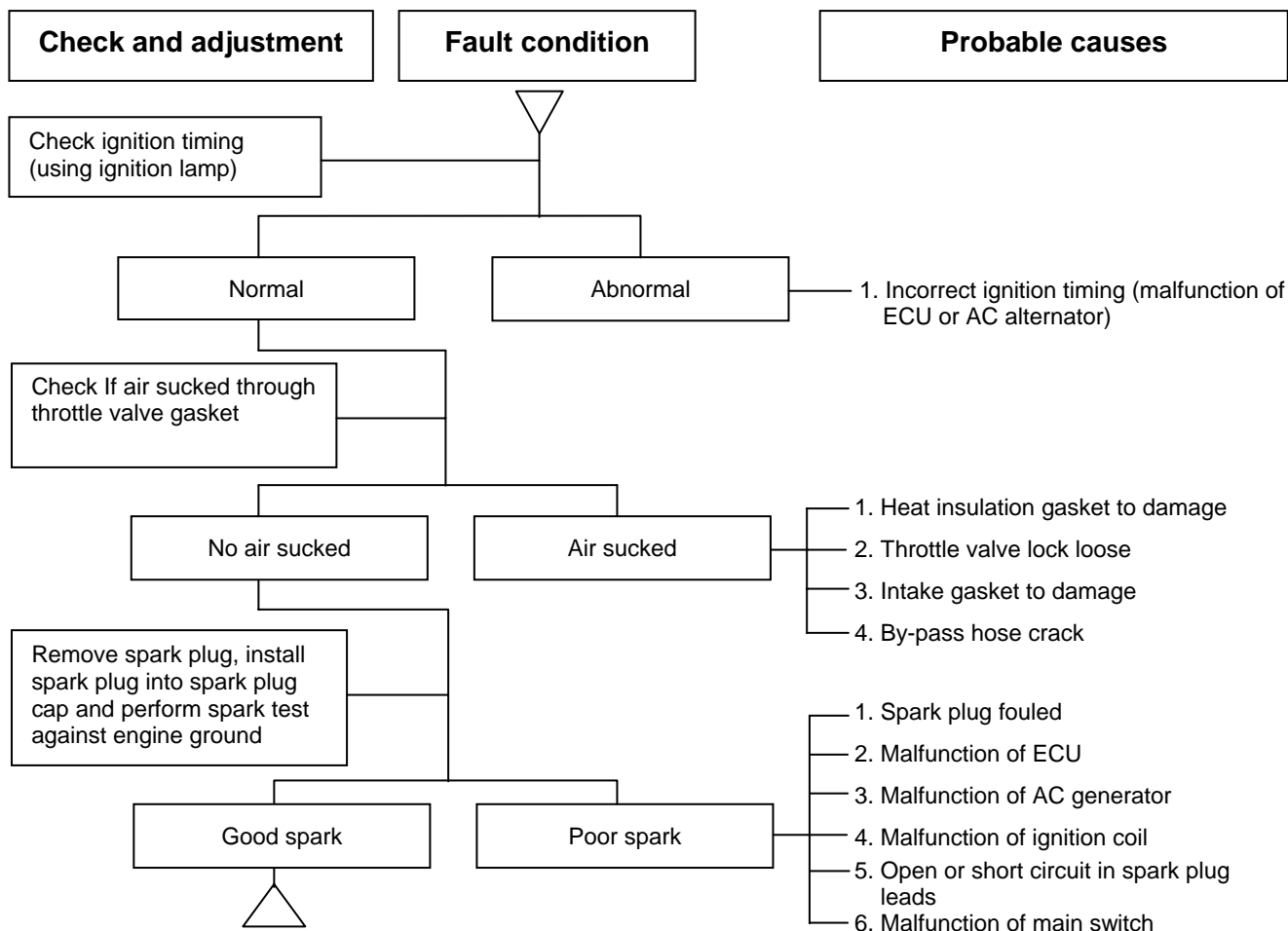

D. Engine runs sluggish (High speed)

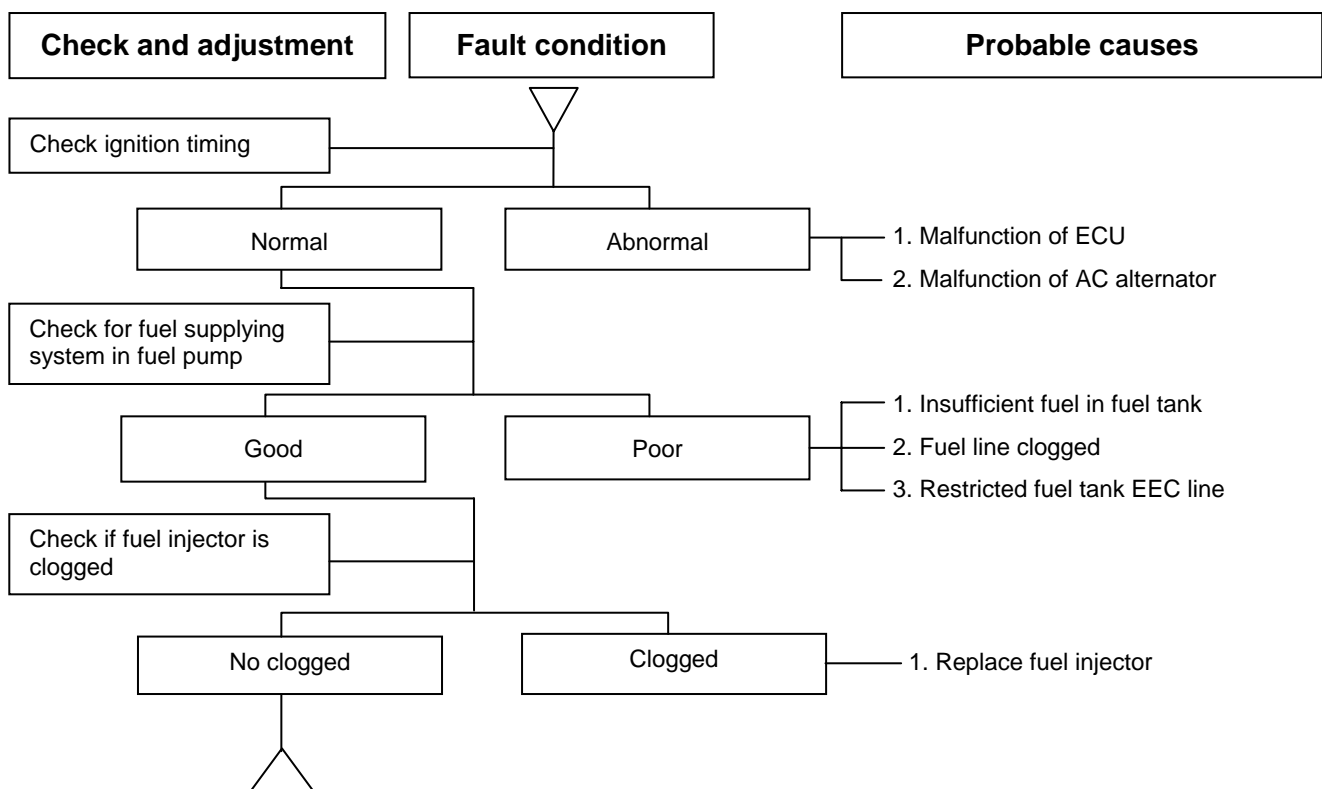

E. Clutch, driving and driving pulley

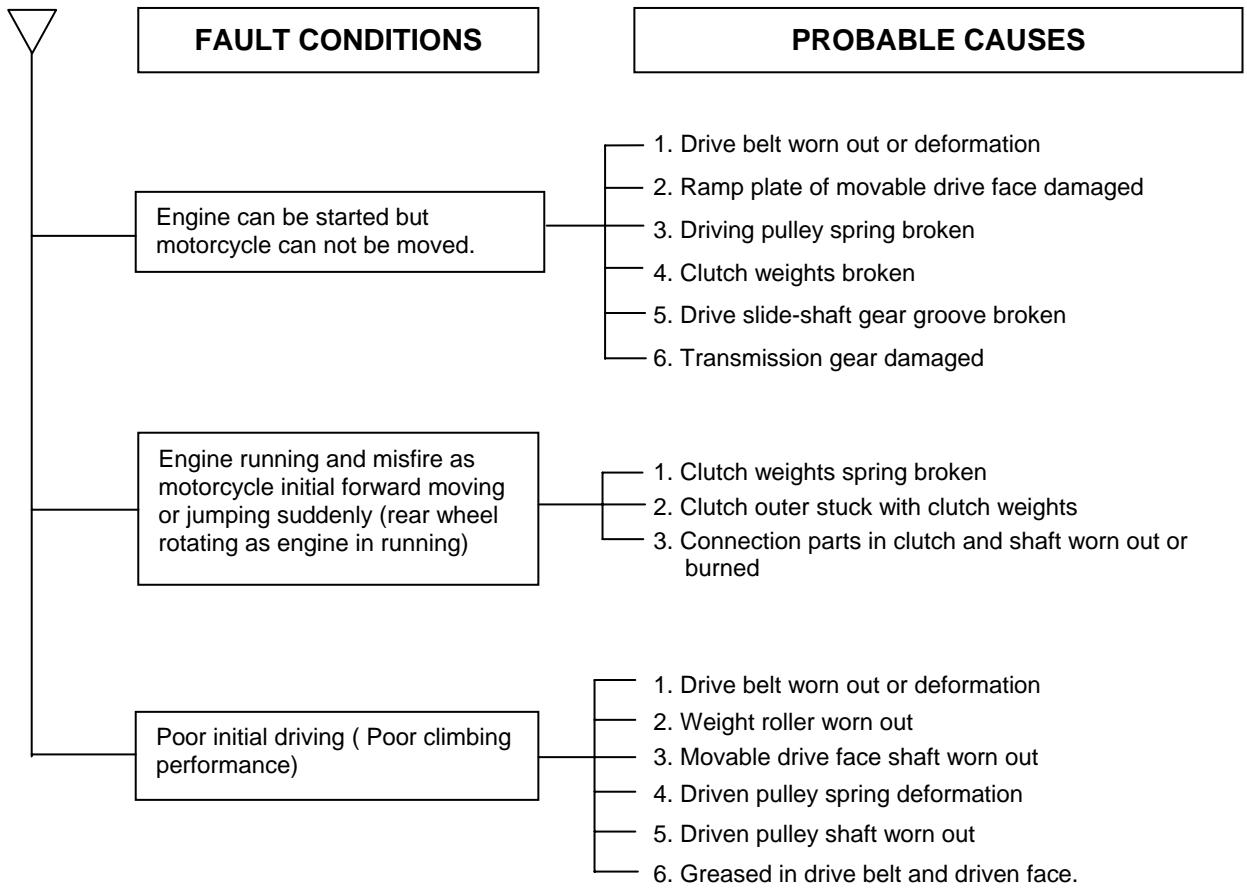

1. General Information/Trouble Diagnosis

Parts To Be Greased

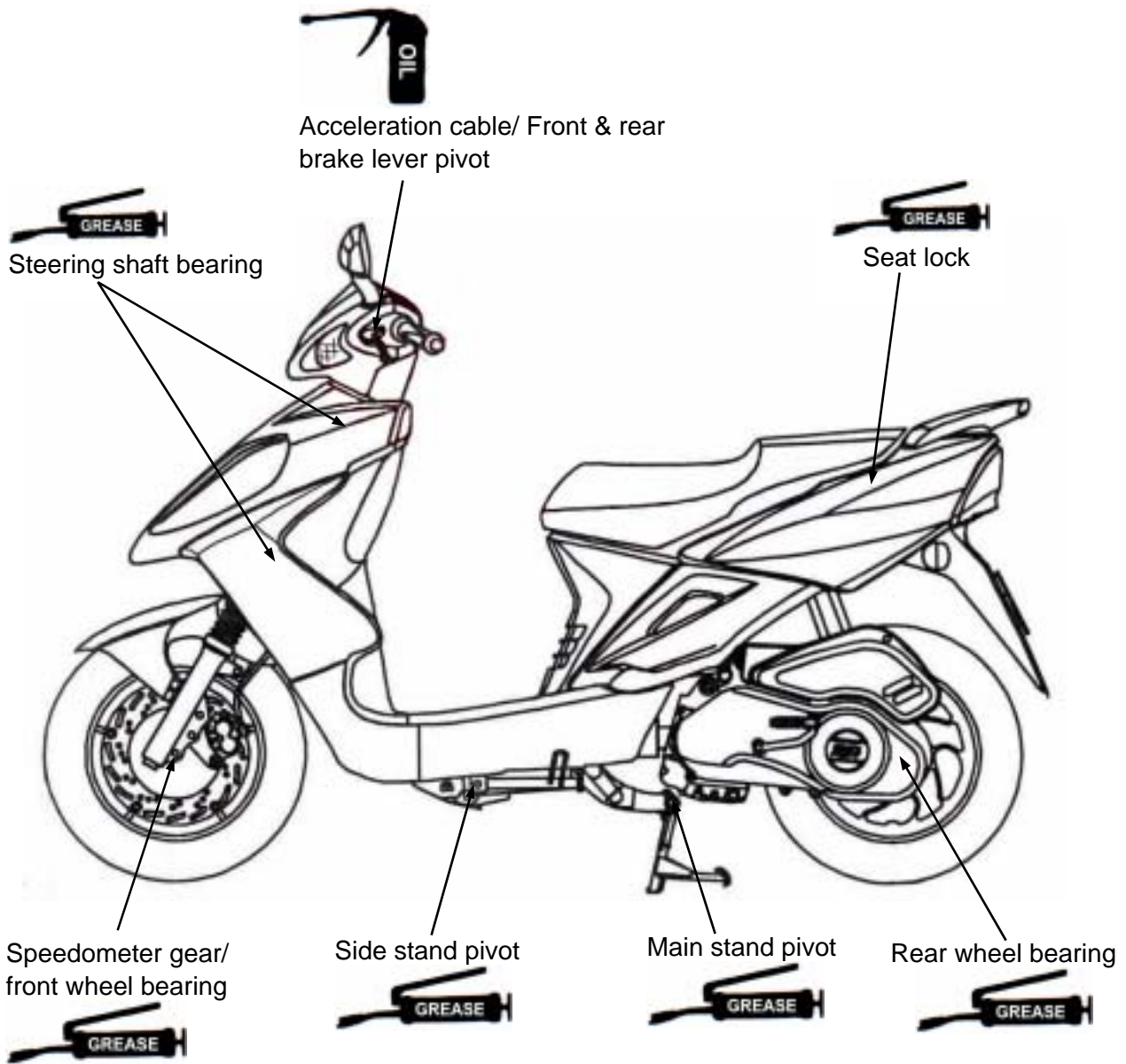

Precautions In Operation 2-1	Spark Plug 2-8
Periodical Maintenance Schedule 2-2	Cylinder Compression Pressure 2-9
Lubrication System 2-3	Driving System 2-9
Gear Oil 2-4	Steering System 2-10
Fuel System 2-4	Suspension System 2-10
Air Cleaner 2-5	Disk Brake System (Front/Rear Disk Brake) 2-11
Throttle Valve Operation 2-5	Wheel / Tire 2-13
Crankcase Ventilation 2-6	Battery 2-14
Valve Clearance Adjustment 2-6	Headlamp Adjustment 2-14
Valve Clearance Inspection And Adjustment 2-7	Nuts, Bolts Tightness 2-14
Idle Speed / Exhaust Gas Adjustment 2-7	Special Service Tools Catalogue 2-15
Ignition System 2-8	

Precautions In Operation

Specification

Fuel Tank Capacity		6100 c.c.
Engine Oil	Capacity	1000 c.c.
	Change	800 c.c.
Transmission Gear oil	Capacity	110 c.c.
	Change	100 c.c.
Clearance of throttle valve		2~6 mm
Spark plug		NGK CR8E Gap: 0.8 mm
"F" Mark in idling speed		BTDC 13° / 1600 rpm
Full timing advanced		BTDC 34° / 8000 rpm
Idling speed		1600±100 rpm
Cylinder compression pressure		12 ± 2 kgf/cm ²
Valve clearance: IN/EX		0.12 ± 0.02 mm
Tire dimension	Front	100/90-12 59J (T/L)
	Rear	130/70-12 59J (T/L)
Tire pressure (cold)	Single	Front: 1.75 kg/cm ² rear : 2.25 kg/cm ²
	Two persons	Front: 1.75 kg/cm ² rear : 2.50 kg/cm ²
Battery		12V8Ah (MF battery) type: YTX9A-BS (8Hr)



2. Maintenance Information

Periodical Maintenance Schedule

Maintenance Code	item	Initial 300KM	1 Month every1000KM	3 month every3000KM	6 month every6000KM	1 year every12000KM
1	Air cleaner	I		C	C	R
2	2nd air jet cleaner	I		C	C	R
3	Fuel filter	I			I	R
4	Oil filter	C			C	C
5	Engine oil change	R	Replacement for every 1000km			
6	Tire pressure	I	I			
7	Battery inspection	I	I			
8	Brake & free play check	I	I			
9	Steering handle check	I	I			
10	Cushion operation check	I	I			
11	Every screw tightening check	I	I			
12	Gear oil check for leaking	I	I			
13	Spark plug check or change	I		I	R	
14	Gear oil change	R	Replacement for every 5000km			
15	Frame lubrication				L	
16	Exhaust pipe	I	I			
17	Ignition timing	I	I			
18	Emission check in Idling	A	I			
19	Throttle operation	I		I		
20	Engine bolt tightening	I		I		
21	CVT driving device(belt)				I	R
22	CVT driving device(roller)				C	
23	Lights/electrical equipment/multi-meters	I	I			
24	Main/side stands & springs	I			I	
25	Fuel lines	I		I		
27	Cam chain	I		I		
28	Valve clearance	I		A		
29	Crankcase vapor control System	I		C		
30	Crankcase blow-by over-flow pipe	I	Replacement for every 2000km			
31	2nd air jet system	I		I	C	
32	vapor control system			I		
33	Throttle body	A	I	A	C	
34	Input signals from EFI ECU				I	
35	Sensors of EMS fuel injector	I		I		

Note: I - Inspection, A-Adjustment R- Replacement C- Cleaning L- Lubrication (The 33rd, 34th, and 35th items are for the fuel injection system)

The above maintenance schedule is established by taking the monthly 1000 kilometers as a reference which ever comes first.

Remarks:

1. These marks " " in the schedule are emission control items. According to EPA regulations, these items must be perform normally periodical maintenance following the user manual instructions.
2. Clean or replace the air cleaner element more often when the motorcycle is operated on dusty roads or in the Heavily- polluted environment.
3. Maintenance should be performed more often if the motorcycle is frequently operated in high speed and after the motorcycle has accumulated a higher mileage.
4. Preventive maintenance
 - a. Ignition system - Perform maintenance and check when continuous abnormal ignition, misfire, after-burn, overheating occur.
 - b. Carbon deposit removal - Remove carbon deposits in cylinder head, piston heads, exhaust system when power is obvious lower. Than ever
 - c. Replace worn out pistons, cylinder head.



Lubrication System

Engine Oil Capacity

⚠ Caution

- The vehicle must be parked on a level ground when checking oil capacity.
- Run the engine for 3-5 minutes then stop, wait about 3-5 more minutes allowing engine oil to settle before checking the oil level.

Remove dipstick to check the oil level. If oil level is below the lower limit mark, add oil to the specified upper limit mark.

Engine Oil change

Shut off the engine and remove dipstick.

Remove the oil drain plug on the bottom-left of crankcase to drain oil.

After draining out oil, clean oil plug and its gasket and reinstall. Replace the gasket if it is damaged.

Torque value: 3.5~4.5 kgf-m

⚠ Caution

Warm up the engine. This will make the oil flow out easily.

Add oil to the specified capacity.

Oil Viscosity: SAE 10W-30, or equivalent recommended using King-Mate serial oil.

**Engine oil capacity: Disassembly: 1050cc
Change: 800cc**

When checking for oil leak, run the engine at idle speed for a few minutes, then check oil capacity with dipstick.

Cleaning the oil strainer

Drain oil from engine, remove the strainer cover, spring and strainer.

If there is an accumulation on the screen, wash it off with suitable solvent (recommended using compressed air to cleaning the foreign).

Check O-ring for damage, replace if necessary. Reinstall strainer, spring, O-ring and strainer cover.

Torque value: 1.3~1.7 kgf-m

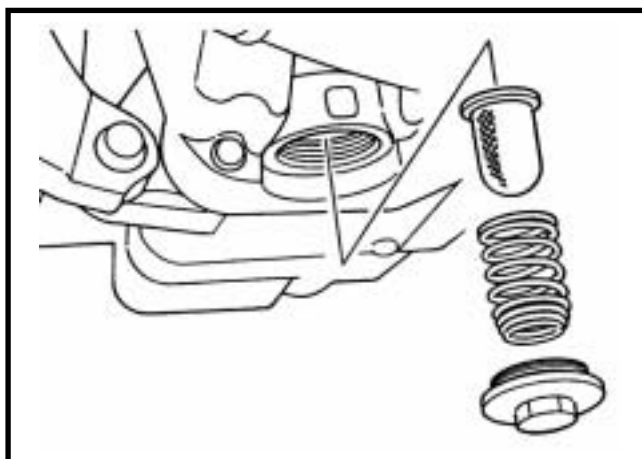
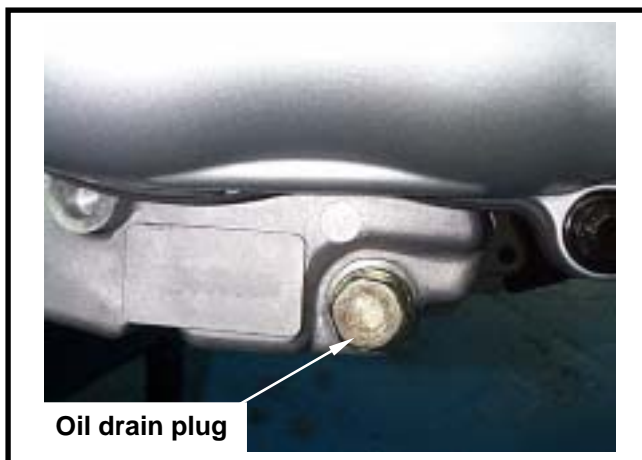

2. Maintenance Information

Gear Oil

Inspection

Check gear oil if leaking.
 Park the motorcycle with main stand on flat level place.
 Turn off engine and remove the gear oil draining plug.
 Place a measurement cup under the draining hole.
 Check gear oil if enough.

Replacement

At first, remove the gear oil refilling bolt, and then remove the draining plug.
 Install the draining plug after drained oil out.

Torque value: 0.8~1.2 kgf-m

Caution

Inspect if washer is in good condition.
 Replace it with new one if it was deformed or damaged.

Fill out specified gear oil from the engine oil filling opening.

Install the oil filling bolt.

Torque value: 1.0~1.4 kgf-m

Quantity: 100 c.c.

Recommended: King-Mate HYPOID GEAR OIL (#140)

Fuel System

Fuel Lines

Remove luggage box, rear carrier, body covers.
 Check all lines, and replace it when they are deterioration, damage or leaking.

Warning

Gasoline is a low ignition material so any kind of fire is strictly prohibited as dealing it.

Fuel filter

Remove luggage box, rear carrier, body covers.
 Remove fuel pump and fuel unit assembly.
 Check if the fuel filter is clogged, broken. If so, clean or replace the fuel filter with new one.

Caution

The arrow on the fuel pump and fuel sender mean the assembly direction of fuel tank, check if it is in corrective installation.

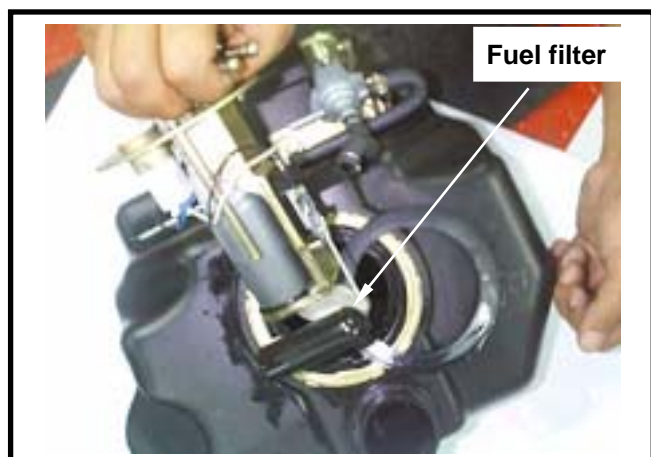
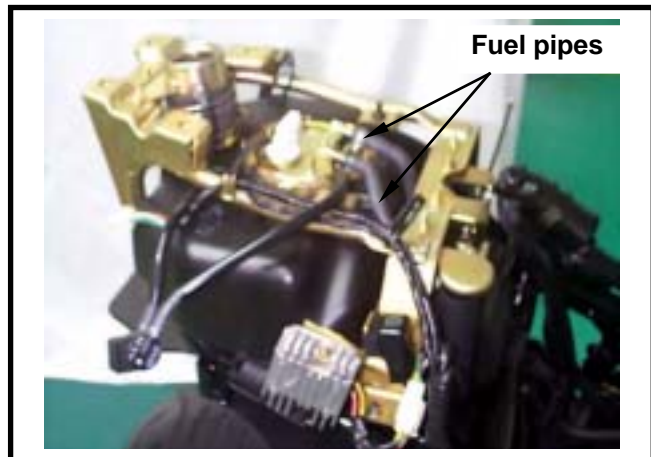

Air Cleaner

Air element

Remove the air cleaner cover (6 screws).

Remove the lock plate from the element of air cleaner.

Check the element if dirt or damaged.

If it is dirty, clean it with solvent and then soap it into cleaning engine oil after cleaned. Finally, squeeze it.

Replace it with new one if dirt or damaged.

Caution

- Make sure that the air cleaner cover had been installed properly after installation because improper installation will cause foreign sucking into cylinder.
- Do not wet the air cleaner as washing the motorcycle. Or it may effect engine performance.

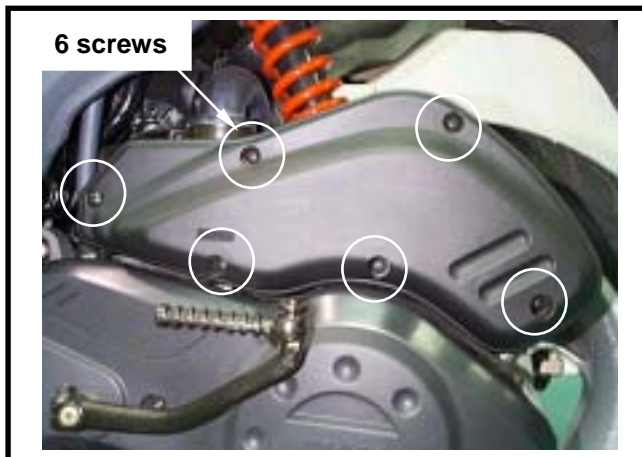

Throttle Valve Operation

Have a wide open of throttle valve as handle bar in any position and release it to let back original (full closed) position.

Check handle bar if its operation is smooth.

Check throttle valve cable and replace it if deteriorated, twisted or damaged.

Lubricate the cable if operation is not smooth.

Measure handle bar free play in its flange part.

Free play : 2~6 mm

Adjustment can be done in either ends.

Secondary adjustment is conducted from top side.

Remove rubber boot, loosen fixing nut, and then adjust it by turning the adjustment nut.

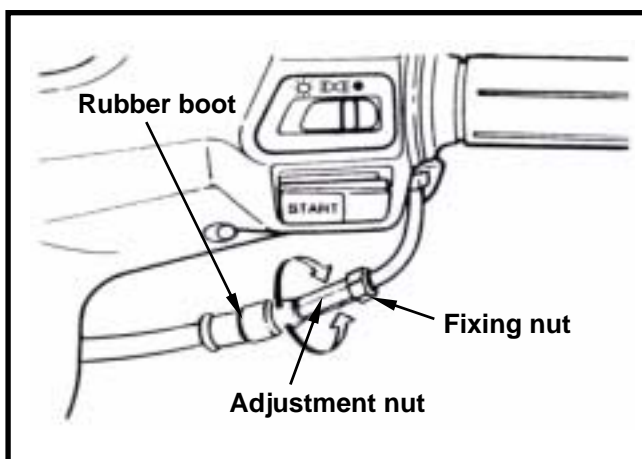
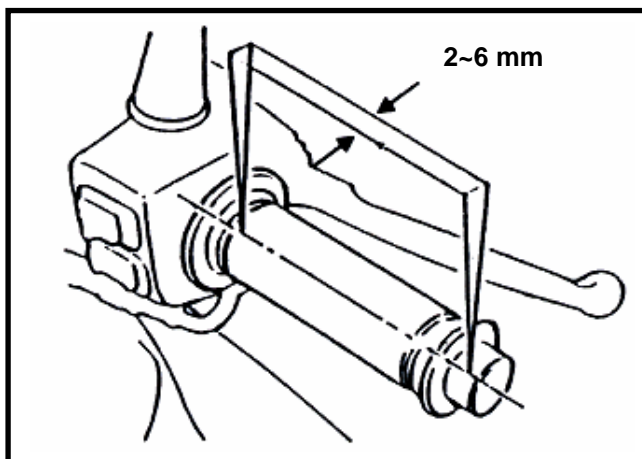

2. Maintenance Information

Primary adjustment is conducted from button side of cable on the throttle body.
Loosen fixing nut, and adjust by turning the adjustment nut for its free-play.
Tighten the fixing nut, and check acceleration operation condition after adjusted.

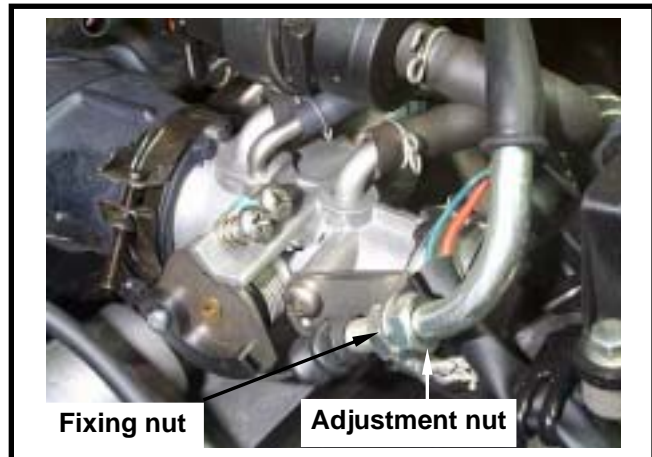

Crankcase Ventilation

Pull out the plug from draining hose to clean deposits.

Caution

When always riding in rainy area or full throttle position, maintenance travel must be shorted. The deposits can be seen in the transparent section of draining hose.



Valve Clearance Adjustment

Caution

Checks and adjustment must be performed when engine is cold (below 35 °C).

Remove luggage box.
Remove center cover.
Remove cylinder head left cap.
Remove the ignition timing check hole cap on the cooling fan cover.
With T type wrench, turn crankshaft in clockwise motion so that mark (T) on the generator flywheel aligns with the mark on the crankshaft, and camshaft is at TDC position also as same as level of cylinder head top-end. A single hole on camshaft sprocket is forward to up. (Piston is at TDC position in the compression stroke.)

Caution

The model that equipped with starting compression pressure reduction system can not be rotated in counter-clockwise to prevent from operating compression pressure reduction function so that valve clearance can not be measured.

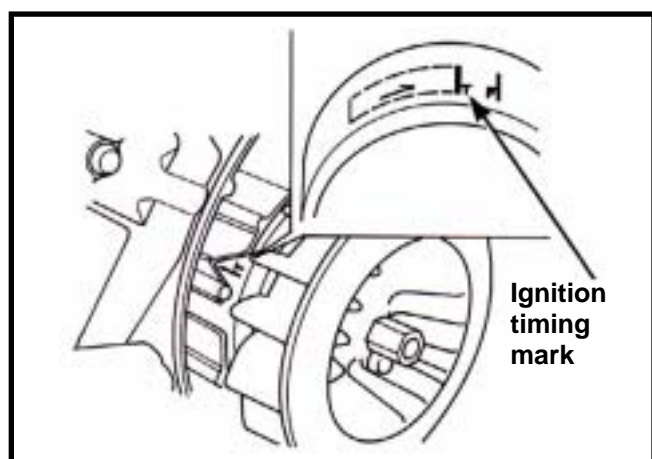
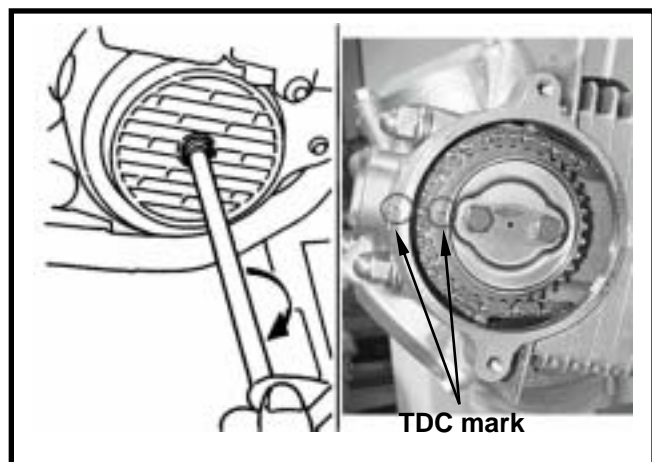



Valve Clearance Inspection And Adjustment

Check & adjust valve clearance with feeler gauge.

Valve clearance (IN/EX): 0.12 ± 0.02 mm

Loosen fixing nut and turn the adjustment nut for adjustment.

⚠ Caution

It has to make sure that valve rock-arm is be adjusted to standard level when adjusting it, and re-check the valve clearance after tightened the fixing nut.



Idle Speed / Exhaust Gas Adjustment

Connect the DATASCAN connector with the body harness connector.

Turn on main switch and start the motor. Then the DATASCAN will open to initial window automatically.

Adjust the Data Scan to data monitor menu.

⚠ Caution

- Inspection & adjustment for idle speed have to be performed after all other parts in engine that needed adjustment have been adjusted.
- Idle speed check and adjustment have to be done after engine is being warm up to working temperature 115~130 . (around 10 minutes)
- This inspection & adjustment have to be done with DATASCAN. Never adjust the adjustment screw on the throttle body arbitrarily to prevent from effect fuel injection precision.

If idle speed and CO have to be adjusted, then turn the DATASCAN to idle speed & CO adjustment function window.

Press "ENTER" key to enter adjustment function. The cursor "▲, ▼" is for a digit and the "◀, ▶" is for denary scale.

Emission standard:

Engine RPM	1600 ± 100rpm
HC	900 ppm
CO	1.5 ± 0.5%

Please refer to chapter 4, fuel system, for the detailed usage of DATASCAN.



2. Maintenance Information

Ignition System

Ignition Timing

Caution

C.D.I ignition system is set by manufacturer so it can not be adjusted.
Ignition timing check procedure is for checking whether CDI function is in normal or

Remove right side cover.

Remove ignition timing hole cap located on the cooling fan cap.

Connect tachometer and ignition lamp.

Start engine and set engine idle speed in 1600 rpm, and if the mark aligns with the "F", then it means that ignition timing is correct.

Increase engine speed to 8000 rpm to check ignition timing advance. If the detent aligns with advance mark "H", then it means ignition timing advance is in functional.

If not, check CDI set, pulse flywheel, and pulse generator. Replace these components if malfunction of these parts are found.

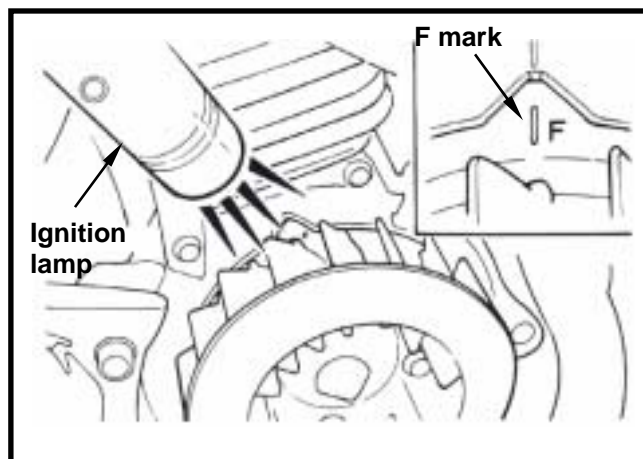

Spark Plug

Appointed spark plug : CR8E (NGK)

Remove trunk.

Remove central cover.

Remove spark plug cap.

Clean dirt around the spark plug hole.

Remove spark plug.

Measure spark plug gap.

Spark plug gap: 0.8 mm

Carefully bend ground electrode of the plug to adjust the gap if necessary.

Hold spark plug washer and install the spark plug by screwing it. Tighten the plug by turning 1/2 turn more with plug socket after installed.

Torque value: 1.0~1.2 kgf-m

Connect spark plug cap.

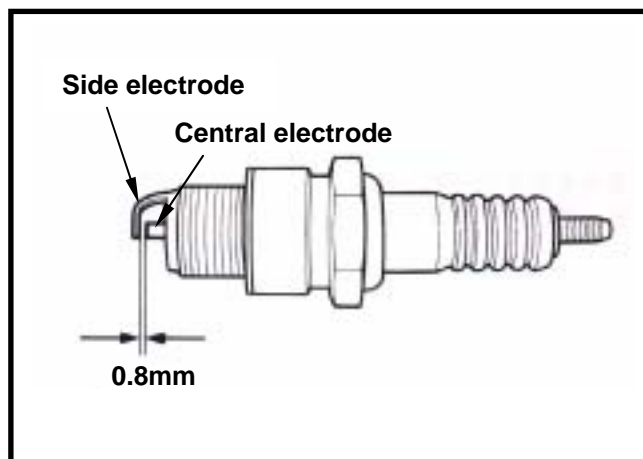
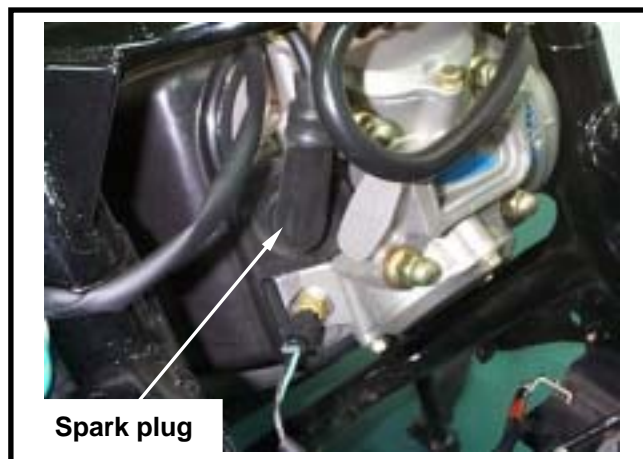

Cylinder Compression Pressure

Warm up engine and then turn off the engine.
 Remove the trunk and the central cover.
 Remove spark plug cap and spark plug.
 Install compression gauge.
 Full open the throttle valve, and rotate the engine by means of stepping the foot-starting lever.

⚠ Caution

Rotate the engine until the reading in the gauge no more increasing.
 Usually, the highest pressure reading will be obtained in 4~7 seconds.

Compression pressure: 12 ± 2 Kg/cm²

Check following items if the pressure is too low:

- Incorrect valve clearance
- Valve leaking
- Cylinder head leaking, piston, piston ring and cylinder worn out

If the pressure is too high, it means carbon deposits in combustion chamber or piston head.

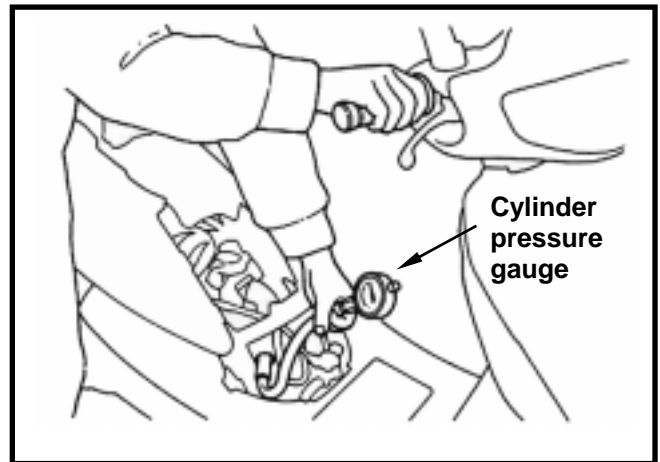

Driving System

Drive Belt

Remove left side cover.
 Remove mounting bolt located under air cleaner.
 Remove 9 bolts of the engine left side cover and the cover.
 Check if the belt is crack or worn out.
 Replace the belt if necessary or in accord with the periodical maintenance schedule to replace it.

Width limit: 18.5mm or more

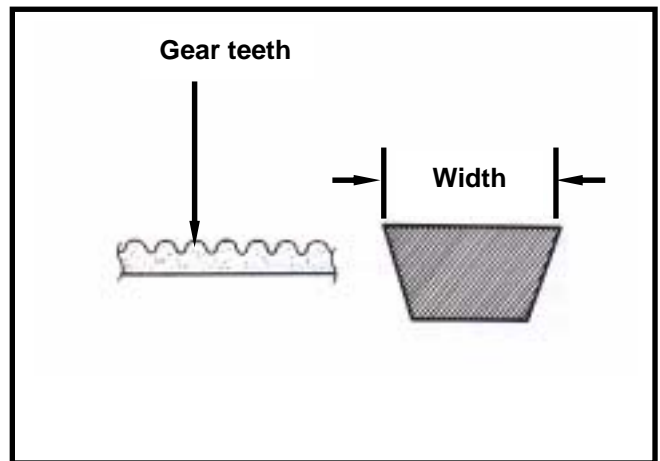

Clutch Pad

Start the motorcycle and gradually increase throttle valve openness to check clutch pad operation.
 If the motorcycle moves with shaking, then check its clutch pad for wearing. Replace it if necessary.

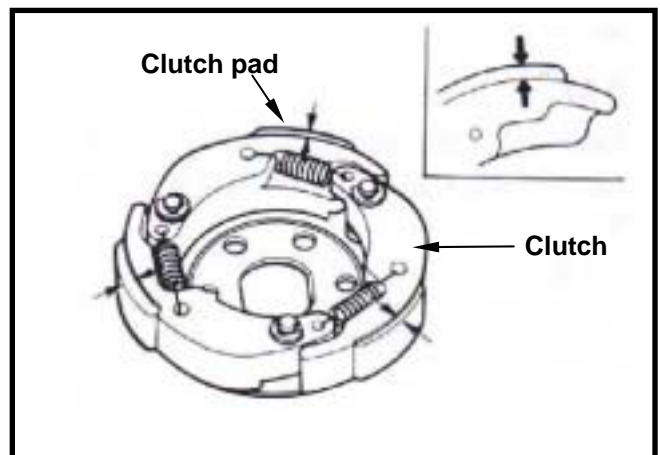

2. Maintenance Information

Steering System

⚠ Caution

Check all wires and cables if they are interfered with the rotation of steering handle bar.

Lift the front wheel out of ground.
Turn handle from right to left alternative and check if turning is smoothly.
If handle turning is uneven and bending, or the handle can be operated in vertical direction, then adjust the handle top bearing.

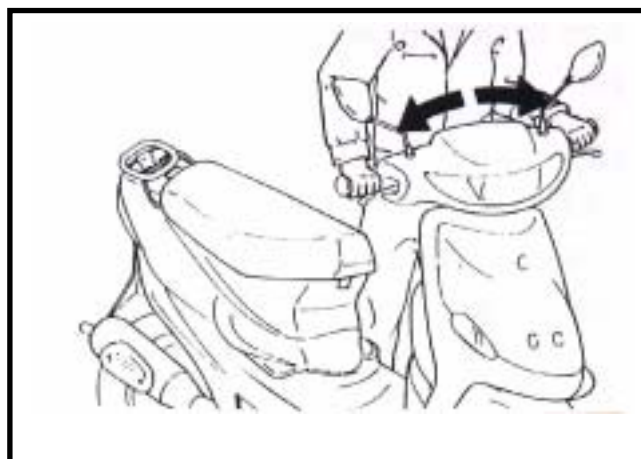

Suspension System

⚠ Warning

- Do not ride the motorcycle with poor shock absorber.
- Looseness, wear or damage shock absorber will make poor stability and drive ability.

Front shock absorber

Hold front brake lever and press down the front shock absorber for several times to check its operation.
Hold front brake lever and push forward the front shock absorber for several times to check its locking status.
Check if it is scratched or leaking.
Replace damaged and non-repairable components.
Tighten all nuts and bolts.

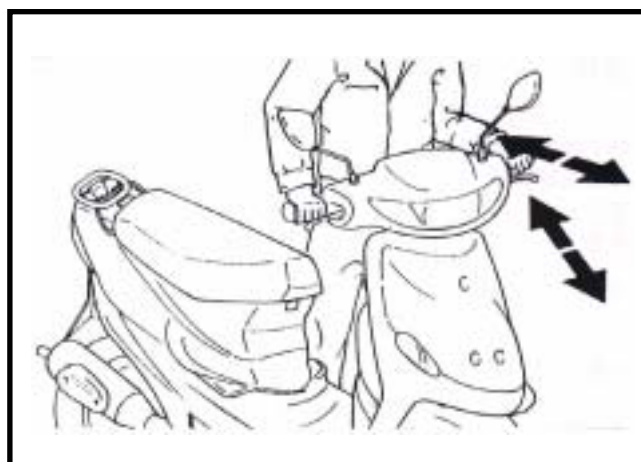

Rear Shock absorber

Press down the rear shock absorber for several times to check its operation.
Check if it is scratched or leaking.
Replace damaged and non-repairable components.
Park the motorcycle with main standard.
Start engine and let the rear wheel rotate after increased engine rpm. Check engine for any parts loose or shaking. Also check the engine suspension bushing for wear out. Replace the bushing if worn out.
Tighten all nuts and bolts.

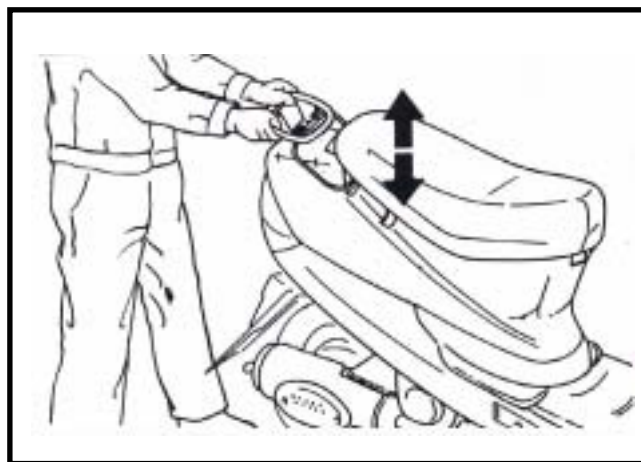



2. Maintenance Information

Disk Brake System (Front/Rear Disk Brake)

Brake System Metal Hoses

Make sure the brake metal hoses for corrosion or leaking oil, and also check brake system for leaking.

Brake Fluid

Check brake fluid level in the brake fluid reservoir. If the level is lower than the LOWER limit, add brake fluid to UPPER limit. Also check brake system for leaking if low brake level found.

Caution

In order to maintain brake fluid in the reservoir in horizontal position, do not remove the cap until handle bar stop. Do not operate the brake lever after the cap had been removed. Otherwise, the brake fluid will spread out if operated the lever. Do not mix non-compatible brake fluid together.

Filling Out Brake Fluid

Tighten the drain valve, and add brake fluid. Place the diaphragm in. Operate the brake lever so that brake fluid contents inside the brake system hoses.

Air Bleed Operation

Connect a transparent hose to draining valve. Hold the brake lever and open air bleeding valve. Perform this operation alternative until there is no air inside the brake system hoses.

Caution

Before closing the air bleed valve, do not release the brake lever.

Added Brake Fluid

Add brake fluid to UPPER limit lever. Recommended brake fluid: DOT3 or DOT4 WELL RUN brake fluid.

Caution

Never mix or use dirty brake fluid to prevent from damage brake system or reducing brake performance.

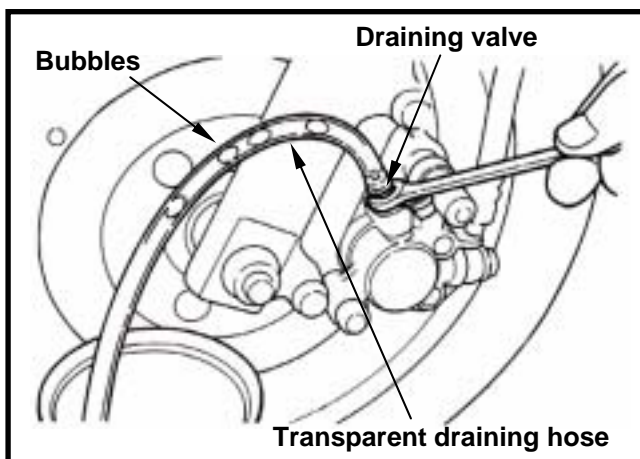
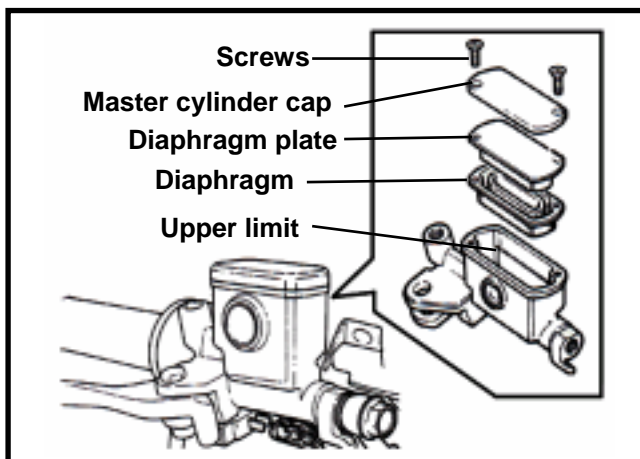
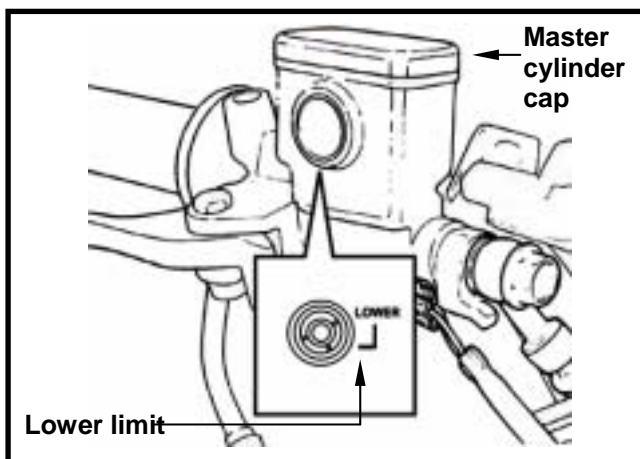
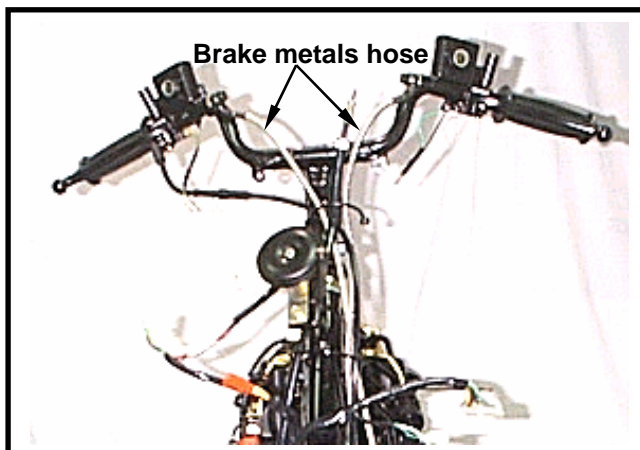

2. Maintenance Information

Brake Lining Wear

The indent mark on brake lining is the wear limitation.

Replace the brake lining if the wear limit mark closed to the edge of brake disc.

⚠ Caution

It is not necessary to remove brake hose when replacing the brake lining.

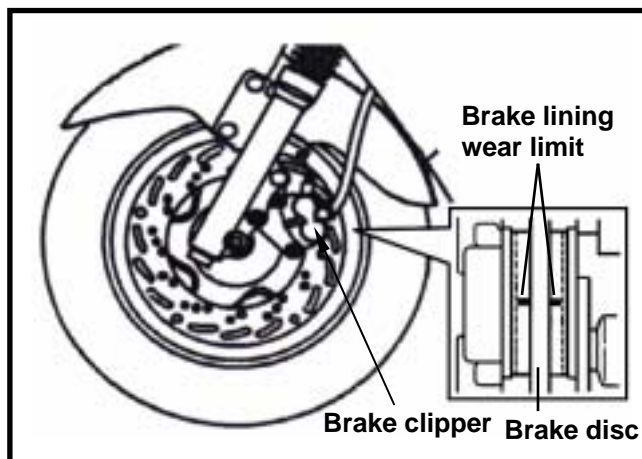

Remove the brake clipper bolt, and take out the clipper.

⚠ Caution

Do not operate the brake lever after the clipper removed to avoid clipping the brake lining.

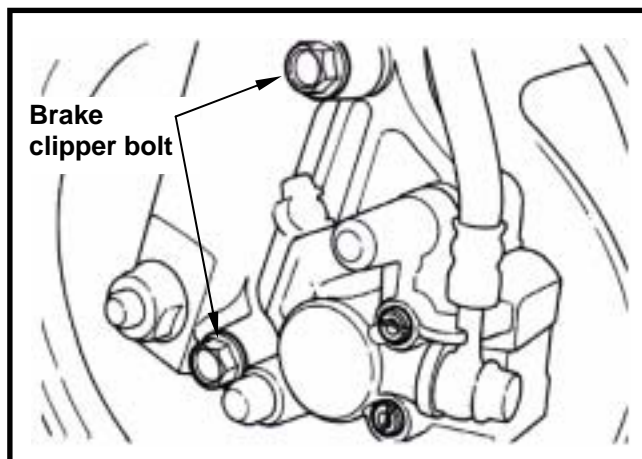

Pry out the brake lining with a flat driver if lining be clipped.

Remove brake lining bolt.
Take out the lining.

⚠ Caution

In order to maintain brake power balance, the brake lining must be replaced with one set.

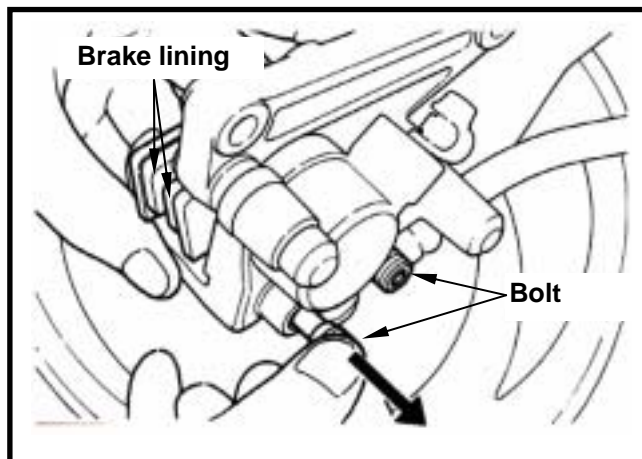

Brake Lamp Switch

The brake lamp switch is to lit up brake lamp as brake applied.

Make sure that electrical starter can be operated only under brake applying.

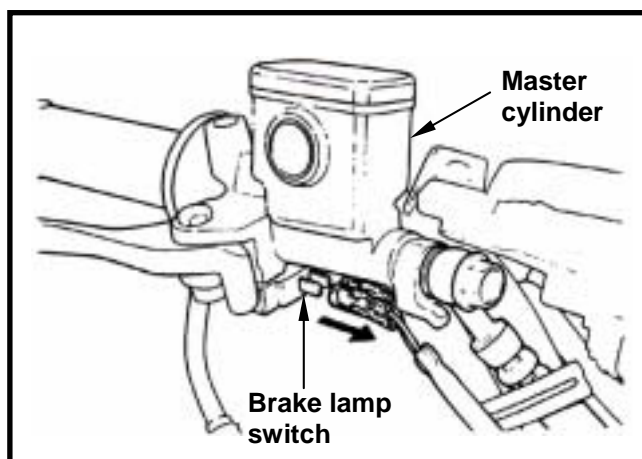



Wheel / Tire

Check if both front & rear tires' pressure is in correct.

⚠ Caution

Tire pressure check should be done as cold tire.

Appointed tire pressure

Tire size		Front tire	Rear tire
Tire pressure as cold tire (Kg/cm ²)	Load for single	1.75	2.25
	Load for two persons	1.75	2.5

Appointed Tire

Front wheel: 100/90-12 59J (T/L)

Rear wheel: 130/70-12 59J (T/L)

Check if tire surface is ticked with nails, stones or other materials.

Check if tire surface or wall for crack or damaged, and replace it if necessary.

The tire tread depth can be checked by visual inspection or depth gauge.

Replace the tire if tire tread dent or unusual wearing out.

The tire should be replaced if the wear limit mark “Δ” is in visible.

Measure tire thread depth from tire central surface.

Replace the tire if the depth is not come with following specification:

Front tire: 1.5 mm

Rear tire: 2.0 mm

⚠ Caution

The wear limit marks “Δ” are located around the tire wall even for inspection.

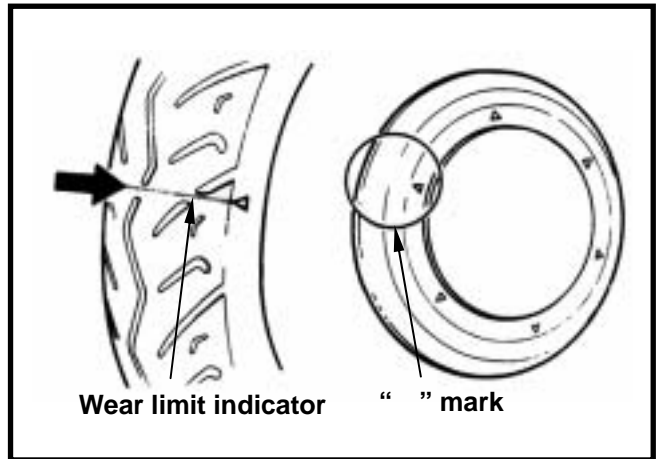
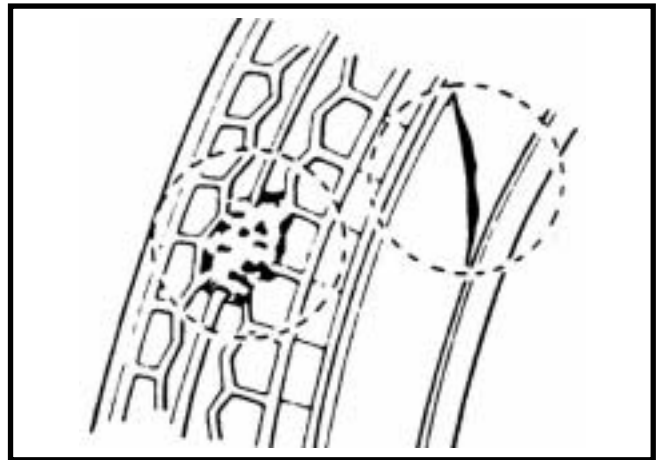
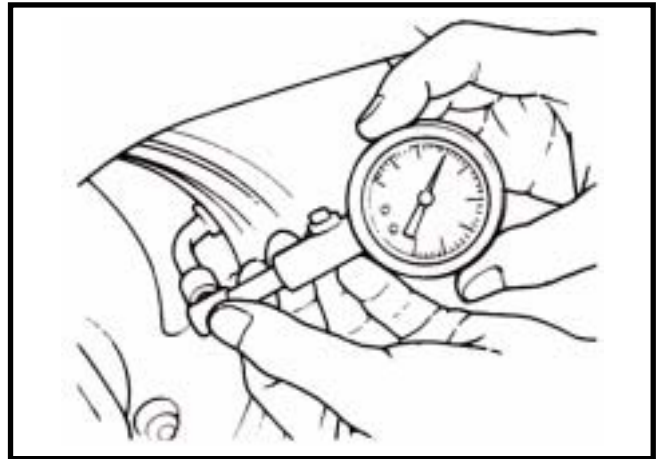

2. Maintenance Information

Battery

Battery Removal

Remove right cover. (3 screws)

Battery cables removal:

1. At first, remove the negative “-” cable.
2. Then, remove the positive “+” cable.
3. Remove the battery.

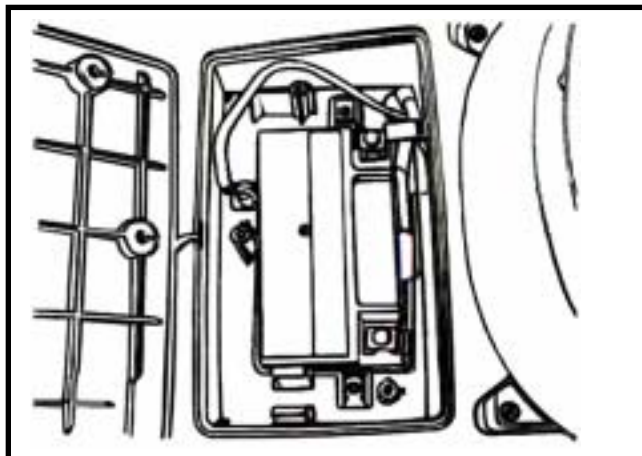

If there is some rust on battery posts, clean it with steel brush.

Install the battery in the reverse procedures of removal.

Caution

- If there is rust on the posts very serious, spray some hot water on the posts. Then, clean it with steel brush so that can remove rust for more easily.
- Apply some grease on the posts after rust removed to prevent from rust again.

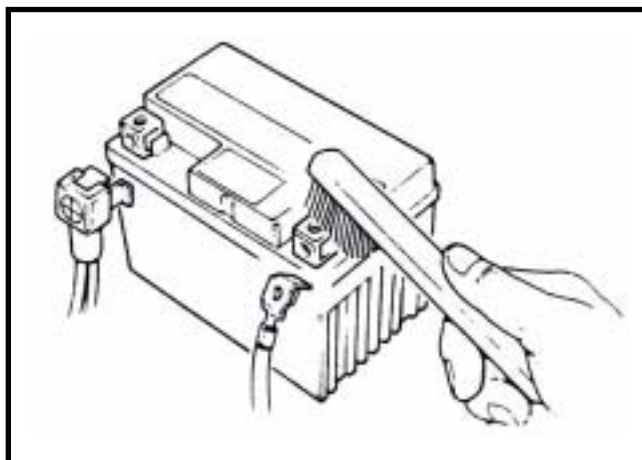

Headlamp Adjustment

Headlamp adjustment

Remove the front fender.

Turn the headlamp adjustment screw to adjust headlamp beam height. (C.W. is for increasing beam height, and C.C.W. is for decreasing beam height)

Reinstall the front fender.

Caution

- To adjust the headlamp beam follows related regulations. Do not adjust it arbitrarily if not necessary.
- Improper headlamp beam adjustment will make in coming driver dazzled or insufficient lighting.

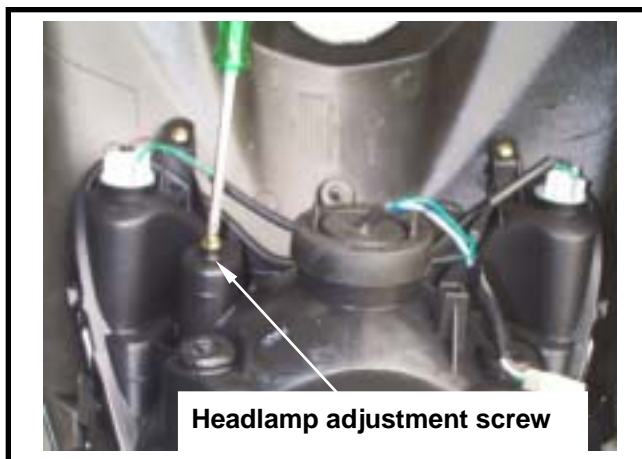

Nuts, Bolts Tightness

Perform periodical maintenance in accord with the Periodical Maintenance Schedule.

Check if all bolts and nuts on the frame are tightened securely.

Check all fixing pins, snap rings, hose (pipe) clamps, and wire holders for security.

Special Service Tools Catalogue

Name	Alternator fly wheel remover	Name	Puller/presser for crankcase bushing (30mm)	Name	Puller/presser for crankcase bushing (22mm)
Parts no.	SYM-3110A01	Parts no.	SYM-1120310	Parts no.	SYM-1120320
Name	Presser for crankcase bushing	Name	Valve spring compressor	Name	Valve spring compressor
Parts no.	SYM-1120300-H9A	Parts no.	SYM-1471100	Parts no.	SYM-1471110/20
Name	Valve clearance adjustment wrench	Name	Universal fixer	Name	Clutch spring compressor
Parts no.	SYM-9001200	Parts no.	SYM-2210100	Parts no.	SYM-2301000
Name	Valve clearance adjuster	Name	Bearing remover (inner type)	Name	Bearing remover (outer type)
Parts no.	SYM-9001210	Parts no.	SYM-6204002	Parts no.	SYM-6204001

2. Maintenance Information



<p>(6301)</p>		<p>(6204)</p>		<p>(6203/6004UZ)</p>	
Name	Bearing installer	Name	Bearing installer	Name	Bearing installer 17mm
Parts no.	SYM-9610000	Parts no.	SYM-9110400	Parts no.	SYM-9620000
<p>(27*42*7)</p>		<p>(25*40*8)</p>		<p>(20*32*6)</p>	
Name	Oil seal installer	Name	Oil seal installer	Name	Oil seal installer
Parts no.	SYM-9125500	Parts no.	SYM-9121600	Parts no.	SYM-9120200
Name	Clutch mounting bolt wrench	Name	Valve cap / Oil filter cap wrench	Name	Fuel pressure gauge
Parts no.	SYM-9020200	Parts no.	SYM-1236100	Parts no.	SYM-HT07010

Mechanism Illustration 3-1	Oil Pump Disassembly 3-4
Operational Precautions:..... 3-2	Oil Pump Inspection 3-5
Trouble Diagnosis 3-2	Oil Pump Re-assembly 3-5
Engine Oil 3-3	Oil Pump Installation 3-6
Cleaning Engine Oil Strainer 3-3	Gear Oil 3-7
Oil Pump Removal 3-4	

Mechanism Illustration

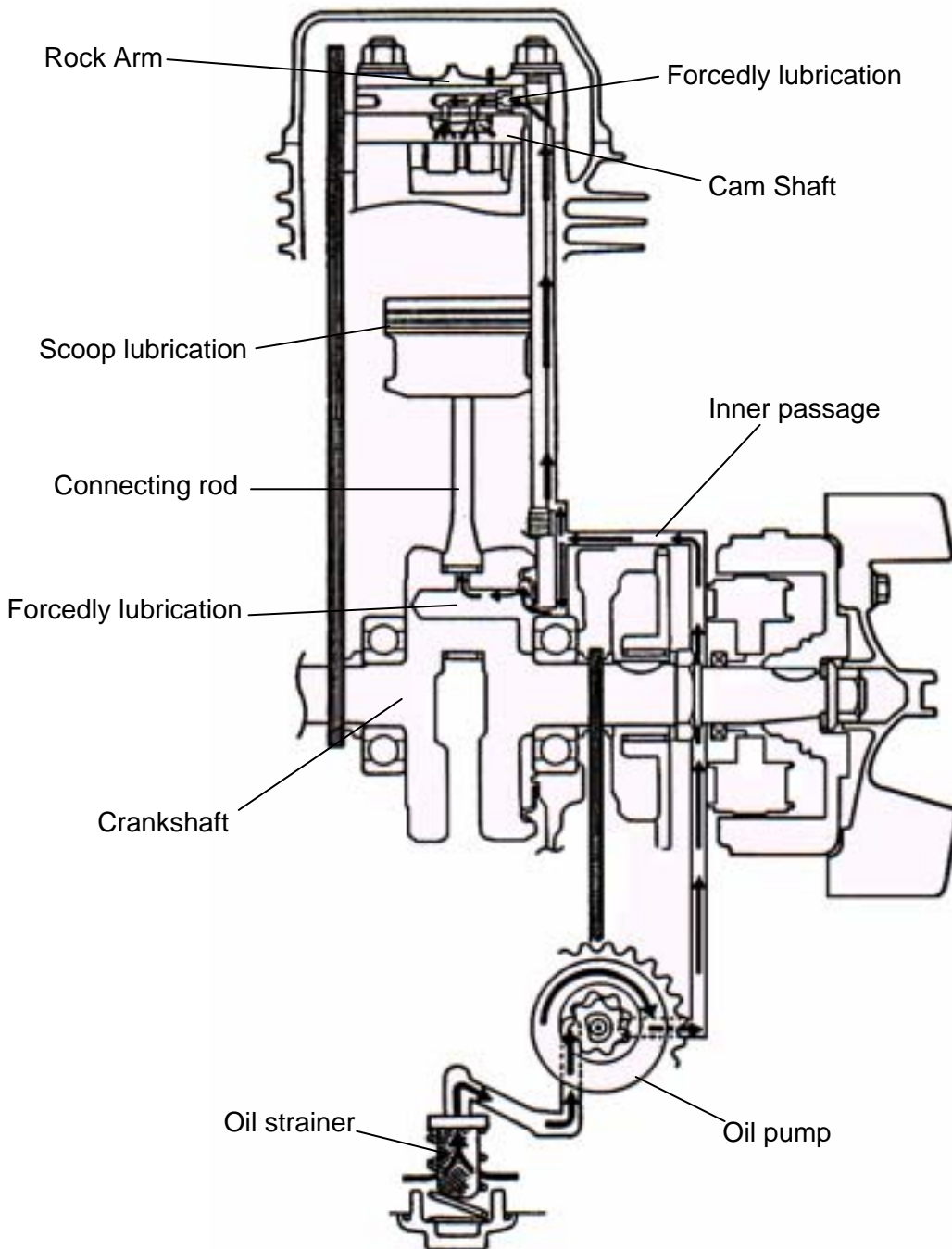

3. Lubrication System

Operational Precautions:

General Information

- This chapter contains maintenance operations for the engine oil pump, engine oil and gear oil.

Specifications

Engine oil quantity	Disassembly 1000 c.c. Replacement 800 c.c
Oil viscosity	SAE 10W-30 or equivalent (Recommended King-Mate serial oils)
Gear Oil	Disassembly 110 c.c. Replacement 100 c.c.
Oil viscosity of gear oil	SAE 85W-140 (Recommended King-Mate gear oil series SYM HYPOID GEAR OIL)

Oil viscosity

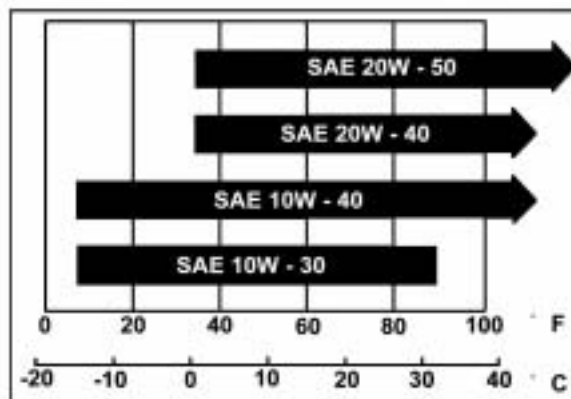

unit: mm

Items		Standard (mm)	Limit (mm)
Oil pump	Inner rotor clearance	-	0.12
	Clearance between outer rotor and body	-	0.12
	Clearance between rotor side and body	0.05~0.10	0.20

Torque value

Engine oil drain plug	3.5~4.5 kgf-m
Engine oil filter cover	1.3~1.7 kgf-m
Gear oil drain plug	0.8~1.2 kgf-m
Gear oil filling bolt	1.0~1.4 kgf-m
Oil pump connection screw	0.1~0.3 kgf-m

Trouble Diagnosis

Low engine oil level

- Oil leaking
- Valve guide or seat worn out
- Piston ring worn out

Dirty oil

- No oil change in periodical
- Cylinder head gasket damage
- Piston ring worn out

Low Oil Pressure

- Low engine oil level
- Clogged in oil strainer, circuits or pipes
- Oil pump damage

Engine Oil

Turn off engine, and park the motorcycle in flat surface with main stand. Check oil level with oil dipstick after 3-5 minutes.

Do not screw the dipstick into engine as checking.

If oil level is nearly low level, fill out recommended oil to upper level.



Oil Replacement

Caution

Drain oil as engine warmed up so that make sure oil can be drained smoothly and completely.

Place an oil pan under the motorcycle, and remove oil strainer cap.

Make sure if the aluminum washer of the draining bolt is damaged. If so, replace it with new one.

Install the drain bolt and tighten it.

Torque value: 3.5~4.5 kgf-m

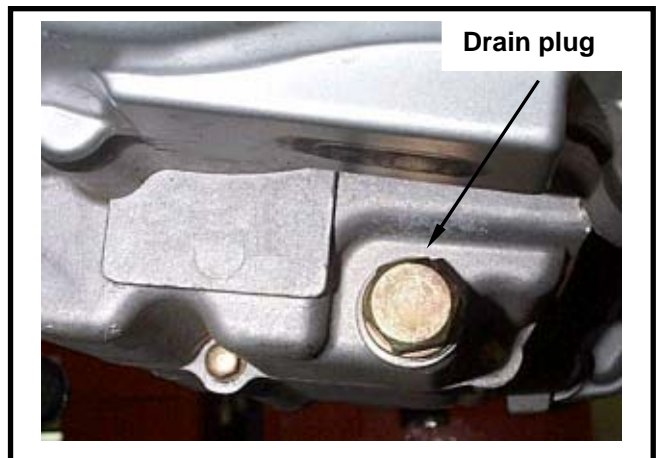

Cleaning Engine Oil Strainer

Remove the oil strainer cap.

Remove oil strainer and spring.

Clean oil strainer. (Recommended using compressed air to clean dirty foreign.)

Check if the strainer and O-ring of the oil strainer are broken. Replace with new one if found.

Install the oil strainer and spring.

Install the oil strainer cap and tighten it.

Torque value: 1.3~1.7 kgf-m

Fill out oil to the oil filler. (Oil viscosity SAE 10W-30) (Recommended King-Mate serial oils)

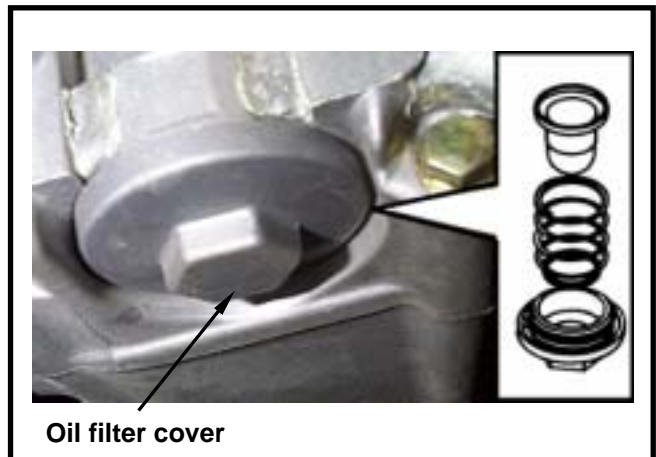

Engine oil quantity: Replacement 800 c.c.

After oil replaced, insert ignition key into the re-set bottom under instrument panel so that the oil indicator is changed from red to green and set oil replacement mileage to zero.

Install dipstick, start the engine for running several minutes.

Turn off engine, and check oil level again if within standard level after 3-5 minutes.

Check if engine oil leaks.

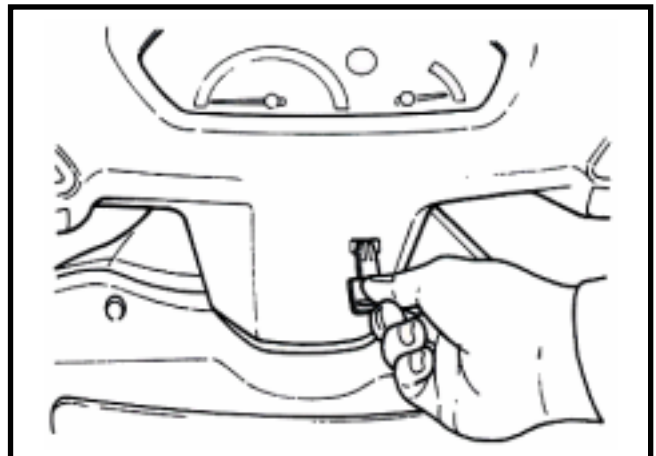

3. Lubrication System

Oil Pump Removal

Remove the alternator (refer to chapter 10).
 Remove the engine right cover.
 Remove the one-way clutch and starting gear (1 nut).
 Make sure that the pump axle can be rotated freely.
 Remove the oil pump cover (2 screws), and then the oil pump driving gear clamp and the gear.
 Remove oil pump body screws (3 screws).



Oil Pump Disassembly

Remove the screws on oil pump cover and disassemble the pump as illustration shown.

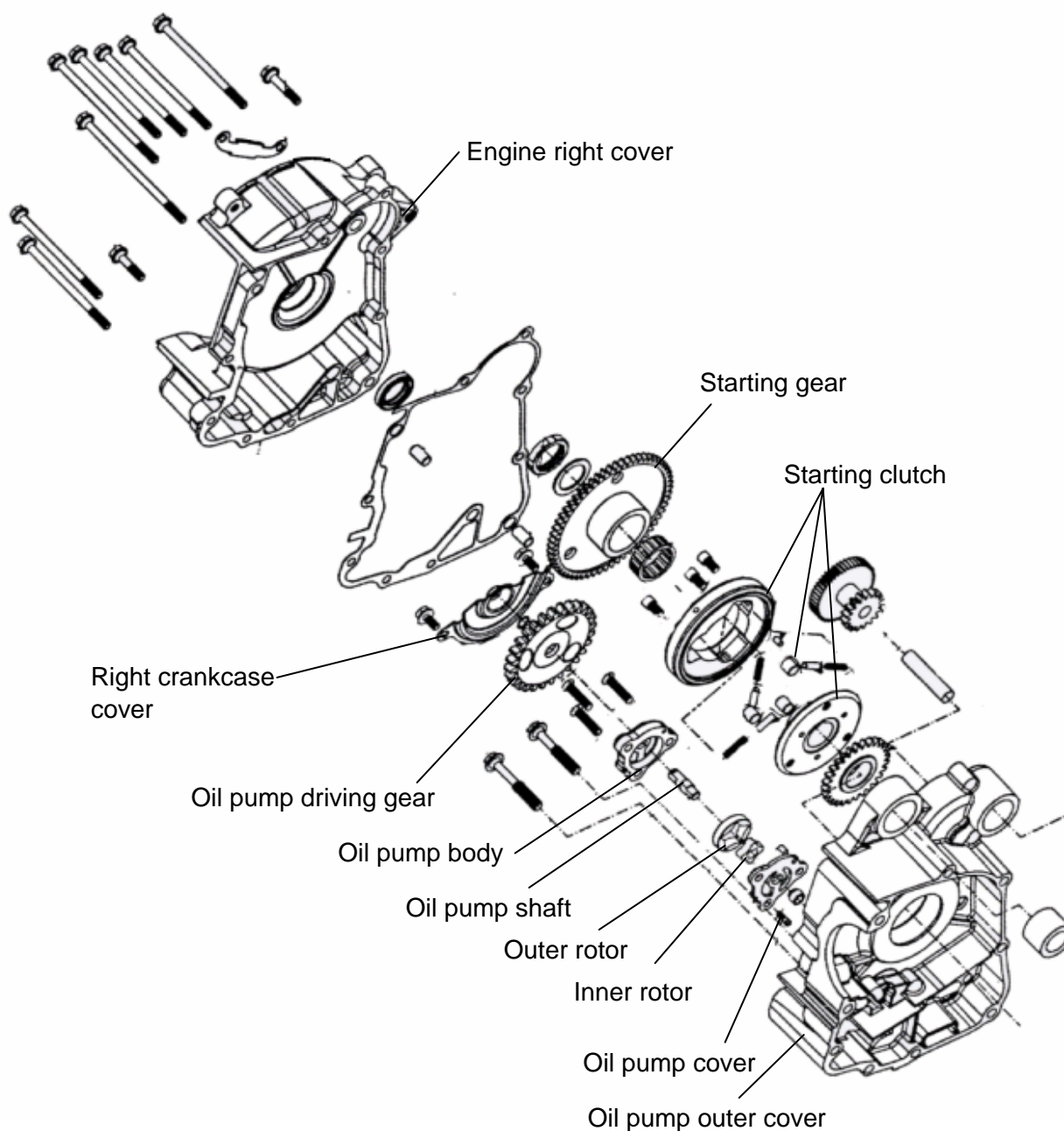

Oil Pump Inspection

Check the clearance between oil pump body and outer rotor.

Limit : below 0.12mm



Check clearance between inner and outer rotors.

Limit: below 0.12mm



Check clearance between rotor side face and pump body.

Limit: below 2.0 mm



Oil Pump Re-assembly

Install inner and outer rotors into the pump body. Align the indent on driving shaft with that of inner rotor. Install the driving shaft.

Install the oil pump cover and fixing pin properly and then tighten screw. (1 screw)



3. Lubrication System

Install driving gear and clamp.

Caution

Install the oil pump cover and fixing pin properly.



Oil Pump Installation

Install the oil pump (3 screws).

Caution

The elliptical hole on the driving gear is not match with the screw hole. Thus, the elliptical hole has to align with the screw hoe before tightening it.

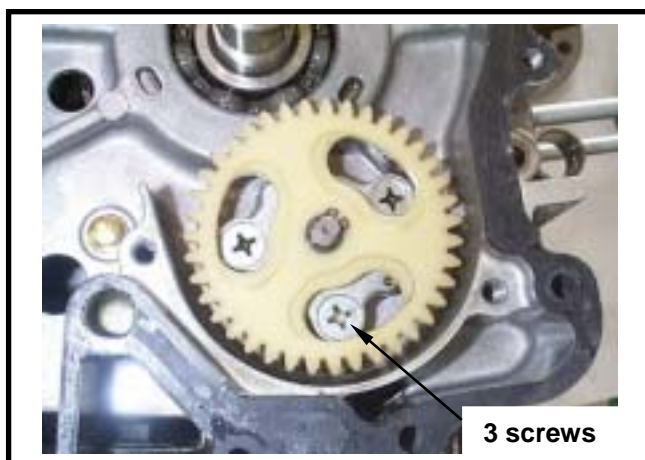

Install oil pump outer cover (2 bolts).

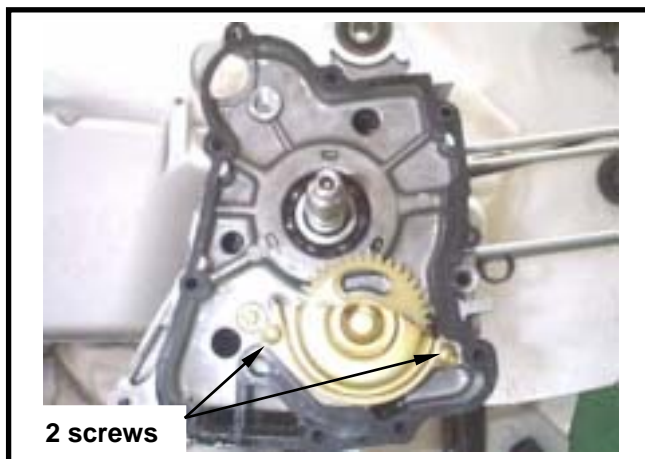

Install the starting gear and the alternator.
(Refer to chapter 10)



Gear Oil

Oil Level Inspection

Park the motorcycle on flat surface with main stand.

Turn off engine and remove both engine oil filling bolt and oil draining plug.



Remove gear oil filling hole bolt and place a measurement cup under the draining plug. Remove the oil draining plug and the pour gear oil into the measurement cup. Measure the gear oil quantity if within standard value. Add specified gear oil if the oil level too low. (Standard quantity: 110cc. / replacement: 100 cc.)

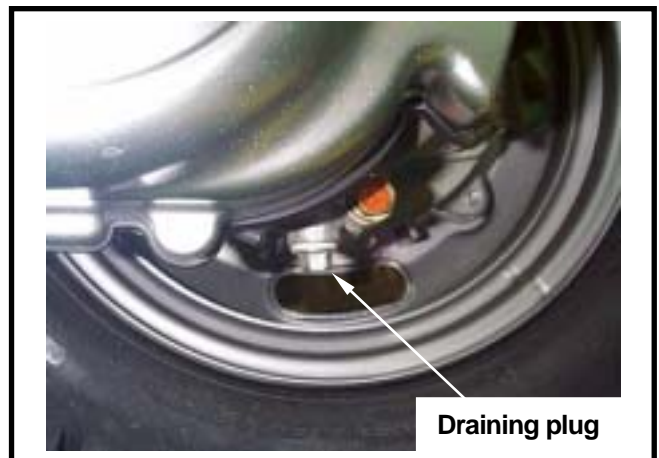

Gear Oil Replacement

Remove the gear oil filling hole bolt and its draining plug and then drain oil completely.

Install the draining plug and tighten it (Make sure if the plug washer is damaged. If so, replace it with new one.)

Torque Value: 0.8~1.2 kgf-m

Add new gear oil (100 c.c.) from the gear oil filling hole and then install the gear oil filling hole bolt after added oil. And then, tighten the bolt.

Torque Value: 1.0~1.4 kgf-m

Recommended to apply with SYM HYPOID

GEAR OIL (SAE 85W-140)

Start engine and run it for 2~3 minutes.

Turn of f engine and check if oil leaking.

3. Lubrication System



NOTES:

Mechanism Illustration 4-1	Air By-pass Valve 4-15
EFI System Components 4-2	Fuel Injector 4-15
Introduction Of Fuel Control System 4-3	Fuel Pump 4-15
Electronical Fuel Injection Components & Operation Principle Introduction 4-3	Fuel Tank 4-16
Precautions In Operation 4-4	Air Cleaner 4-19
Trouble Diagnosis 4-5	Trouble Diagnosis & Solutions Of EFI 4-20
Components Description Of Efi. 4-9	Error Code Message and Solution Operation 4-21
Fuel Lines 4-11	EFI Data scan Operation Manual 4-23
Ignition System 4-12	EFI Component Malfunction Check & Replacement Procedure (PI Engine) 4-36
Crank Position Sensor 4-13	
Temperature Sensor 4-14	

Mechanism Illustration

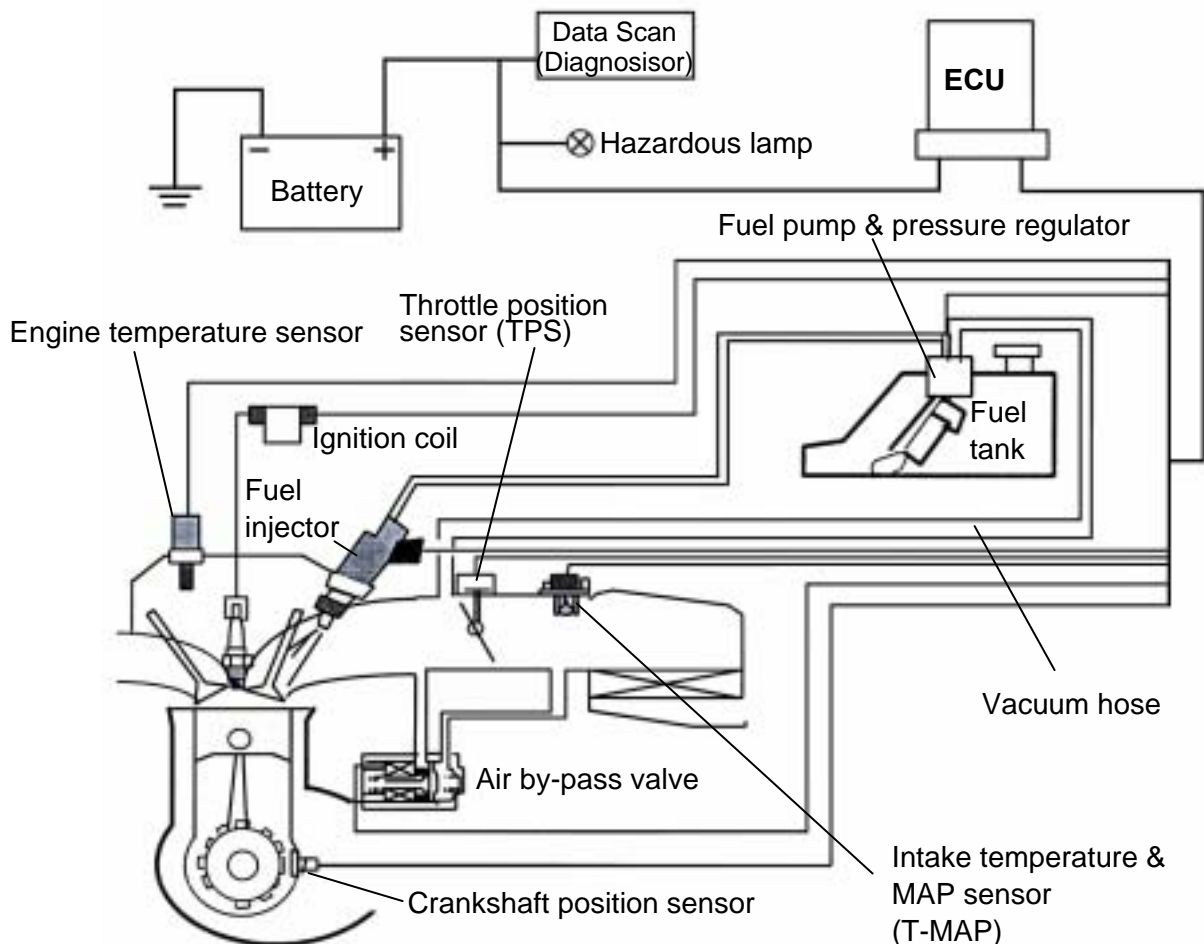

4. FUEL INJECTION SYSTEM

EFI System Components

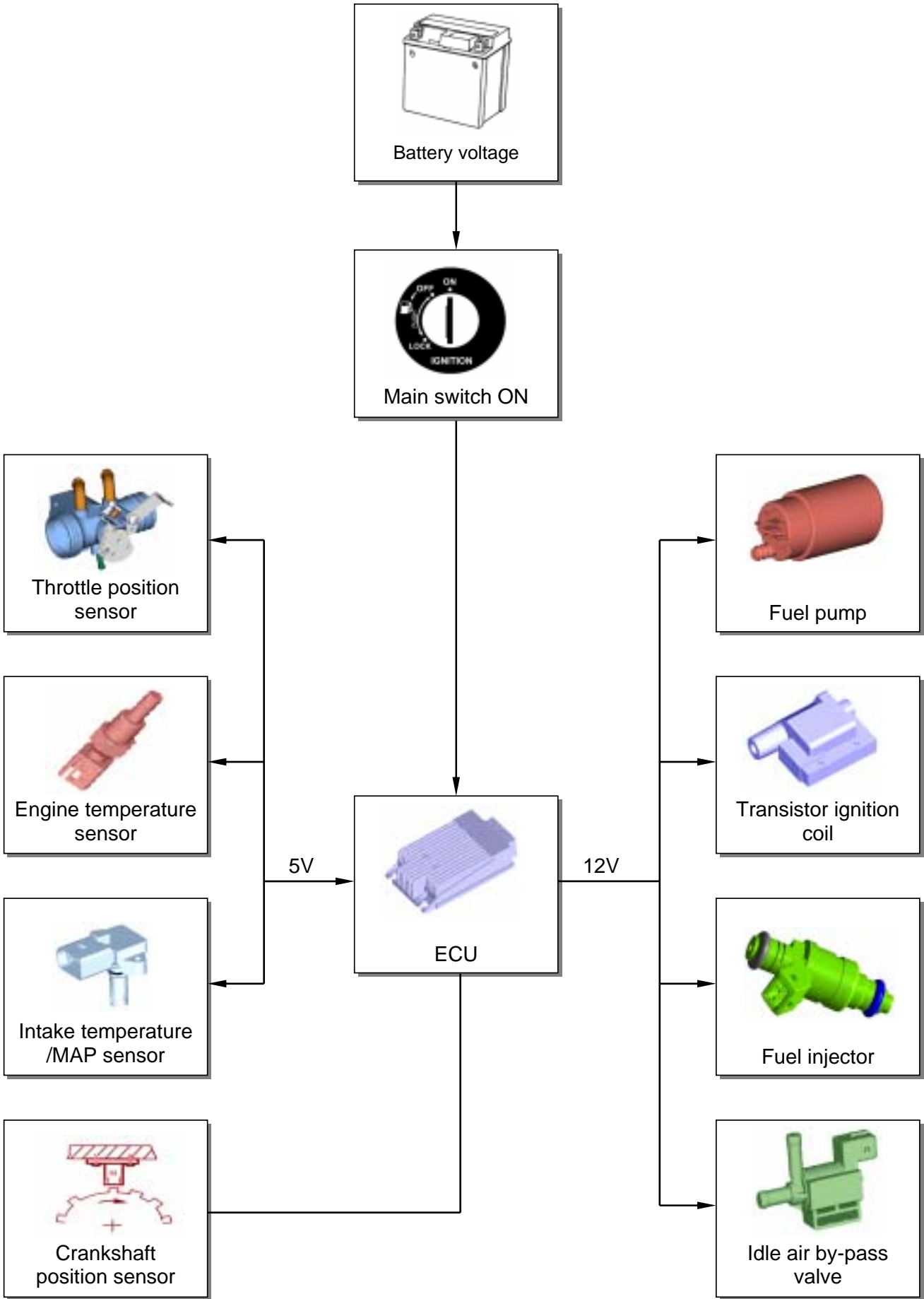

Introduction Of Fuel Control System

The engine of this model was based on a 150 c.c. four-stroke & 4-valve SOHC electronic controlled single cylinder, air-cooler, engine. It adopts a charcoal canister to absorb the fuel vapor generated through evaporation in the fuel system & crankcase. Then, introducing evapor into combustion chamber.

Electronic Fuel Injection Device:

This device consists of both the fuel supply system ---fuel tank, electrical fuel pump, fuel filter, and fuel pump regulator as well and the fuel control system---fuel injector and ECU.

Fuel is delivered to the fuel injector onto the intake manifold through fuel tank to fuel pump. Fuel pressure is kept within 2.5bar by means of the fuel regulator. Then, the injection signal from ECU is to let fuel inject to cylinder in every crankshaft rotation. In addition, the residual fuel is back to fuel tank by the fuel regulator. The fuel pump is stalled into the fuel tank so that can reduce noise and simplify the fuel pipe routing. The electronic controlled ignition & injection system can control fuel consumption & emission efficiently so that reaches to the purpose of environmental purification.

Fuel delivery way in most of motorcycle's engines is by carburetor. The absorption capacity of engine is to create vacuum inside of the carburetor so that fuel is suck into combustion chamber with air. Therefore, under such operation, air & fuel mixture ratio is decided by flowing air and fuel absorbed quantity. Thus, the 3 factors, air detective quantity, fuel quantity decision and fuel absorbed quantity, are conducted inside of the carburetor.

However, as for the fuel injection system, it detects air absorbed quantity and temperature. Thus, the fuel supply quantity is decided by the default preset in the system computer. Then, fuel is injected out by the fuel injector. Comparing with carburetor engine, the 3 factors are independent, and can increase their precision easily so that fuel supply can be much more accurate.

The engine is equipped with a fuel injection of computerized control and its main characters are as following:

1. The necessary fuel injection quantity is decided by correspondence with engine rotation. And, the engine also is applied with a good reaction and high accurate throttle valve. (So, fuel injection quantity and timing are decided by engine RPM and the throttle valve opening.)
2. The decision of fuel injection quantity and injection timing are controlled by a 8-bite highly accurate micro-computer.
3. The pressure regulator is always to keep the variances of intake manifold and fuel pressures in a constant value (2.5bar). So, with the change of intake manifold pressure, the fuel injection quantity can be kept in proper level.
4. The engine can measure the manifold pressure to enrich fuel injection based on high position level so that enhance driving capacity.
5. The idle speed control system is to provide manifold with the 2nd air to increase idle speed's stability and starting capacity.

Electronical Fuel Injection Components & Operation Principle Introduction

The electronic fuel injection components is consists of both the fuel supply system ---fuel tank, electrical fuel pump, fuel filter, and fuel pump regulator as well and the fuel control system---fuel injector and ECU.

Fuel is delivered to the fuel injector onto the intake manifold through fuel tank to fuel pump. Fuel pressure is kept within 2.5bar by means of the fuel regulator. Then, the injection signal from ECU is to let fuel inject to cylinder in every crankshaft rotation (i.e. the fuel supply system is to inject fuel to cylinder one time. In addition, the residual fuel is back to fuel tank by the fuel regulator through the fuel return pipe. In order to reduce noise and simplify the fuel pipe routing the fuel pump usually is designed to install into the fuel tank.

Generally speaking, the electronic controlled ignition & fuel injection system can control fuel consumption & emission efficiently so that reaches to the purpose of environmental purification.

4. FUEL INJECTION SYSTEM

Precautions In Operation

General Information

Warning

Gasoline is a low ignition point and explosive materials, so always work in a well-ventilated place and strictly prohibit flame when working with gasoline.

Cautions

- Do not bend or twist throttle valve cable. Damaged cable will make unstable drive ability.
- When disassembling fuel system parts, pay attention to O-ring position, replace with new one as re-assembly.

Specification

Item	
Idle speed	1600±100 rpm
Throttle handle free play	2~6 mm

Torque value

Engine temperature sensor: 0.74~0.88 kgf-m

Tool

Special service tools

Vacuum/air pressure pump

Injection system diagnosis (Data Scan)



Trouble Diagnosis

EFI Electrical Circuit Inspection

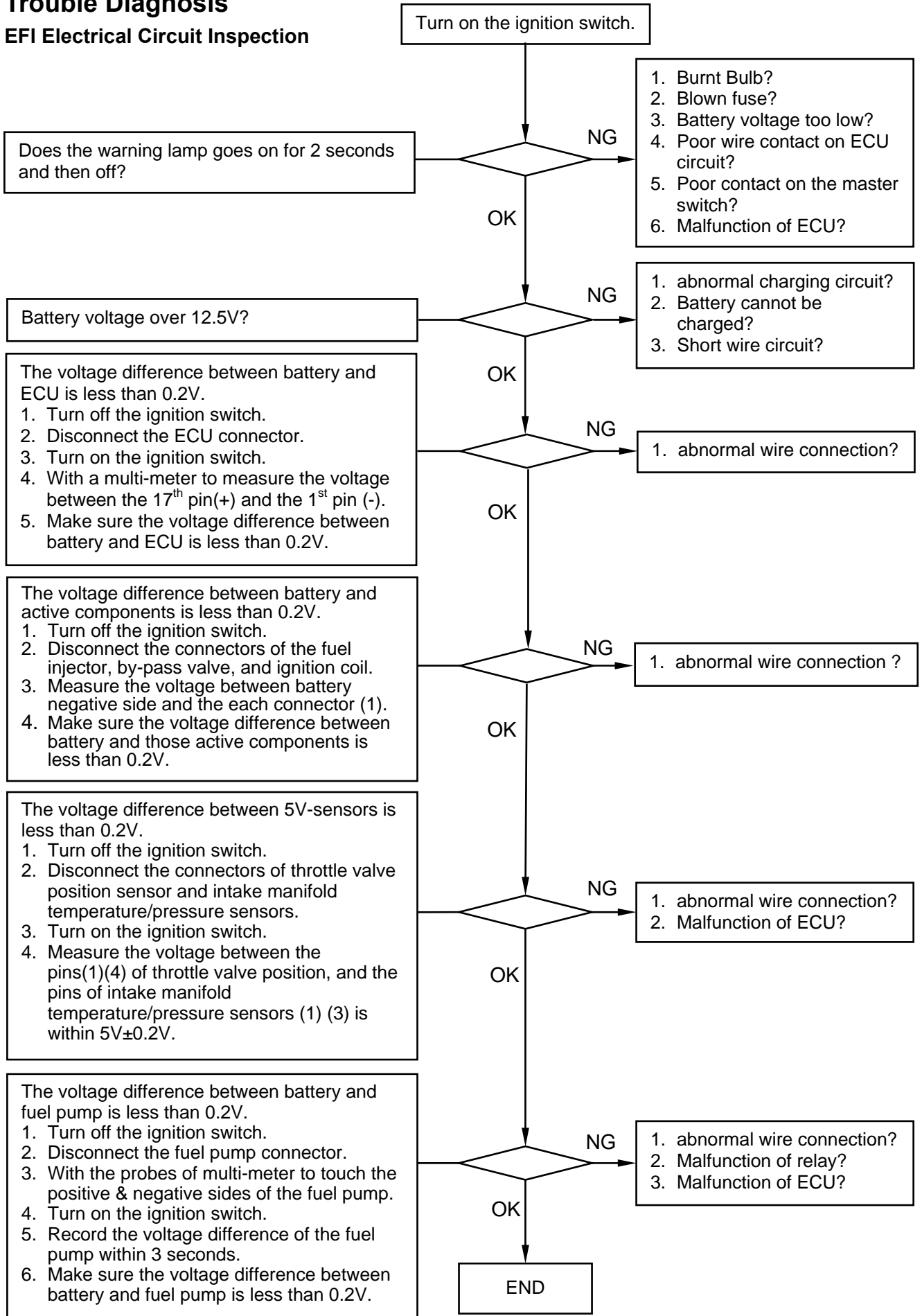

4. FUEL INJECTION SYSTEM

Engine cannot be started or difficult to start.

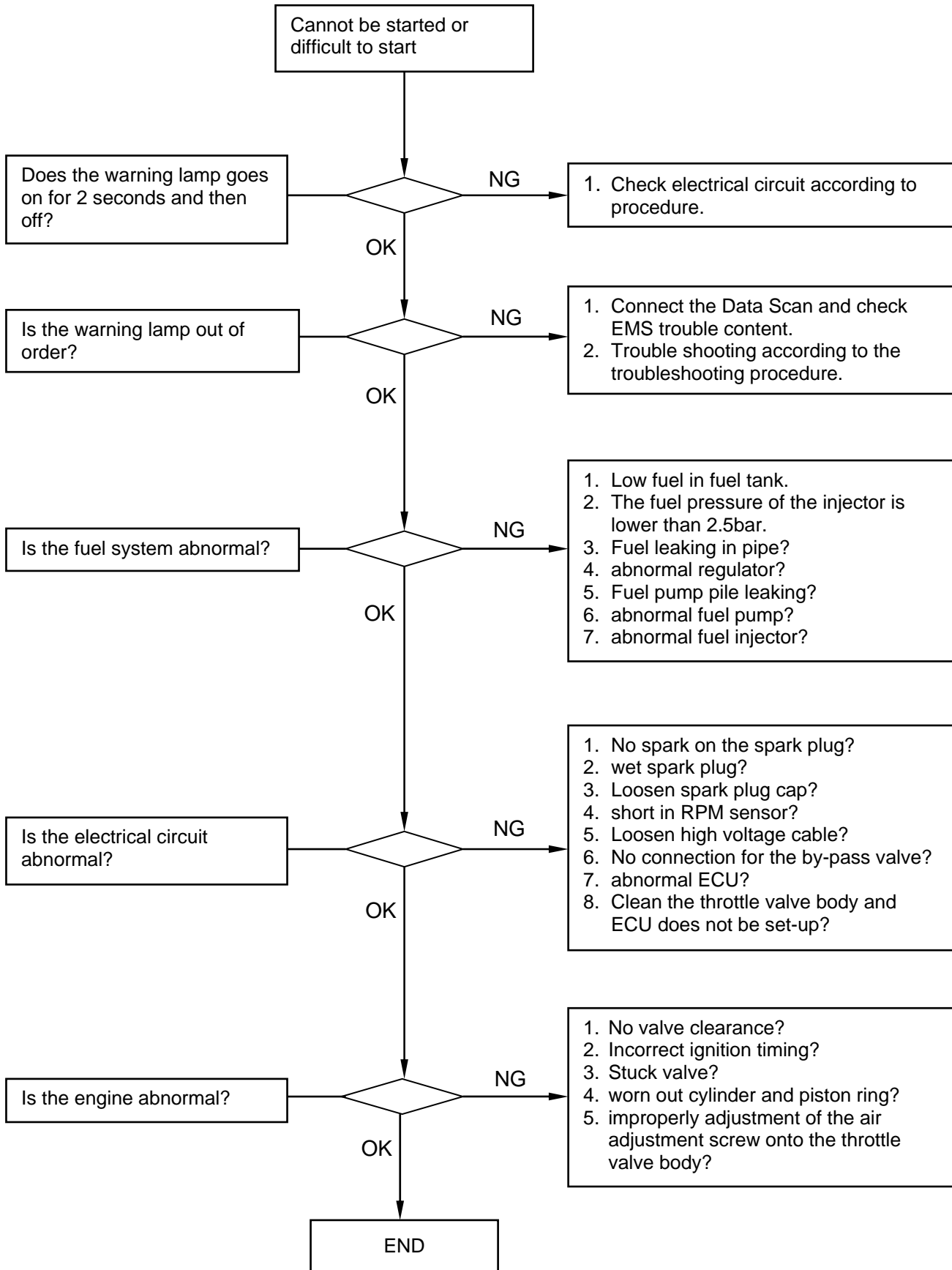

Diagnosis Of Idle Speed Misfire

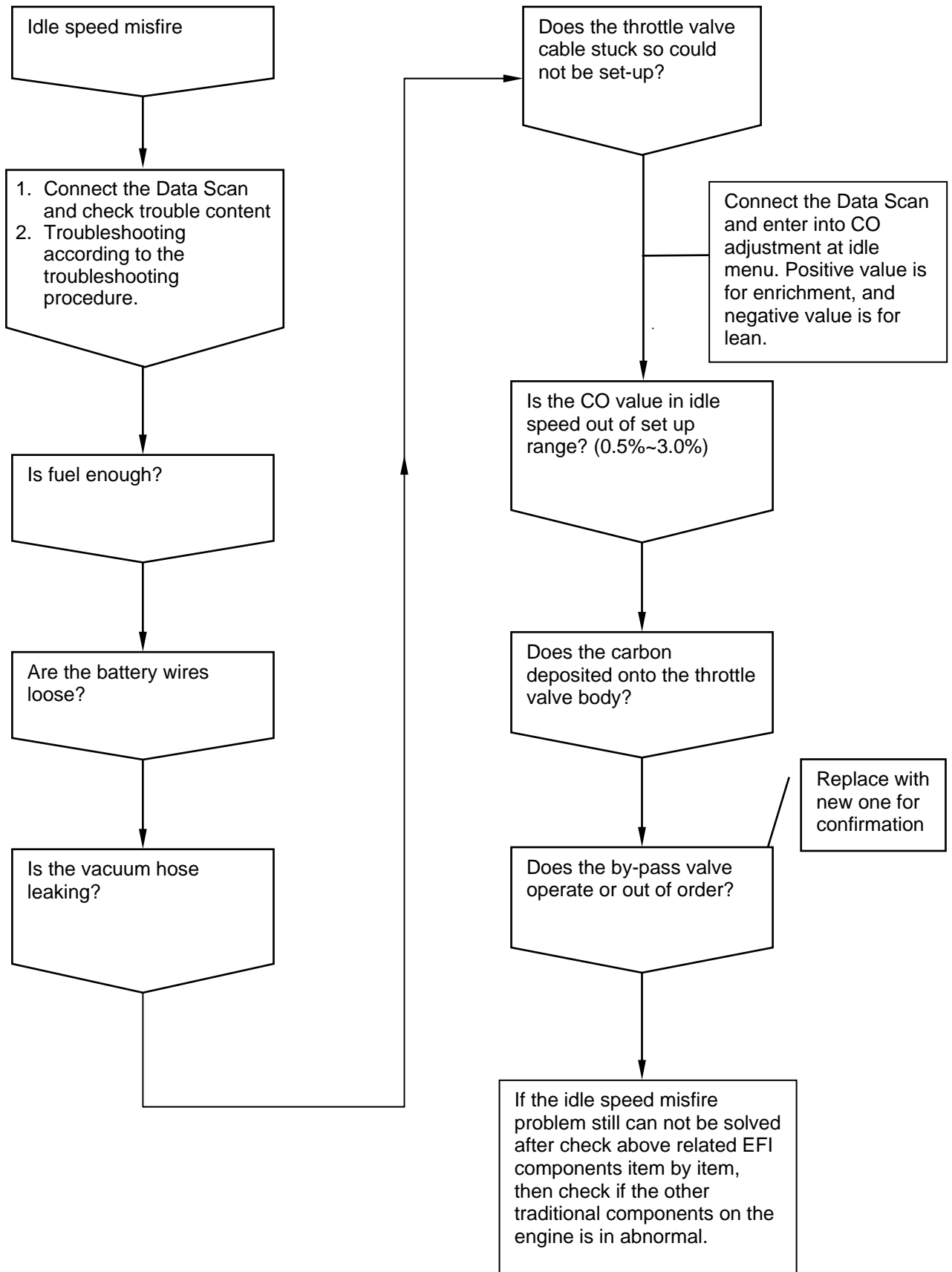

4. FUEL INJECTION SYSTEM

Abnormal CO Correct Value

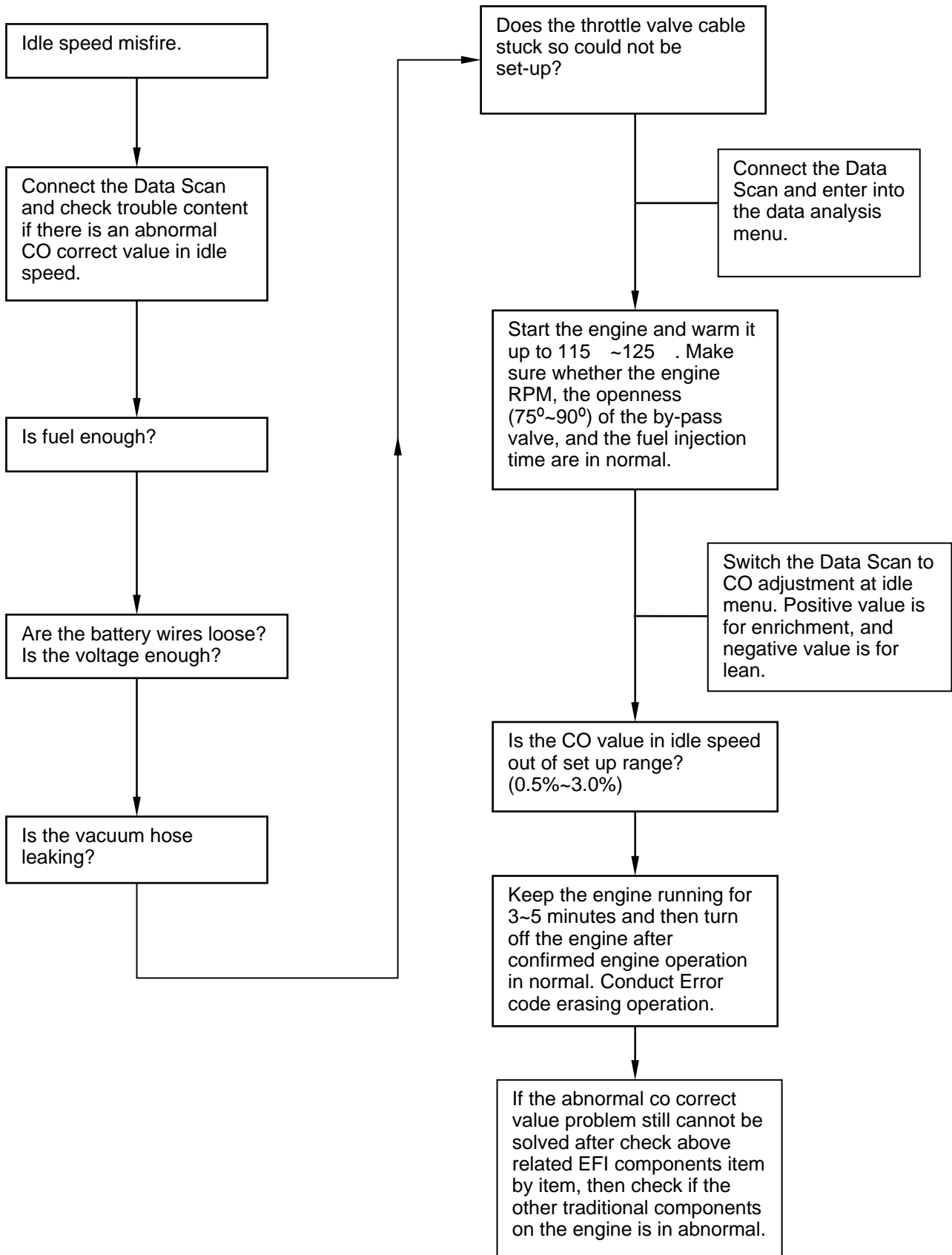

Components Description Of EFI

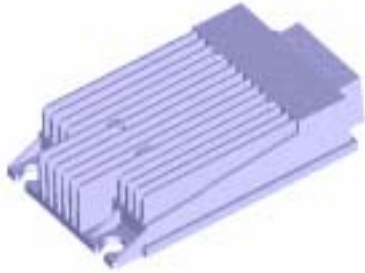

ECU (Electronic Control Unit):

Powered by DC 8~16V, and has 22 terminals connector on the unit. The hardware component consists of an 8-bite computer that be its control center. It contains the functional circuit interface of engine condition sensing and the driving actuator for the by-pas valve, fuel injector, and fuel pump, as well as transistor ignition coil. Its major software is a monitor strategy operation program that includes with controlling strategy, MAP and self-diagnosis programs.



Fuel Injector:

Powered by DC 8~16V, and has 2 terminals connector on the injector. Its major component is the solenoid valve of high resistance driven by voltage. The two terminals are connected to power source and ground respective. It is controlled by ECU to decide the injection timing, and the injector pulse width. Working with 4-valve engine, the unique 2-hole designed injector can provide each intake valve with suitable fuel quantity to reduce HC emission.



Fuel Pump:

Powered by DC 8~16V, and has 2 terminals connector on the pump. The two terminals are connected to power source and ground respective. The ECU is to control and manage the operation of fuel pump through electrical power. Its major component is a driving fan pump that equipped with a low electrical consuming DC motor. Powered by 12V voltage and keep fuel pressure inside the fuel pump in 2.5 bar which can offer 14 liter fuel per hour. The fuel pump is located inside of the fuel tank, and installed a filter in front of its inlet so that can prevent from foreign materials sucking into the fuel pump to damage it and the fuel injector.



By-pass Valve for Idle Speed:

Powered by DC 8~16V, and has 2 terminals connector on the pump. The two terminals are connected to power source and ground respective. The ECU is to control and manage the operation of by-pass valve through electrical power. Its major component is the solenoid valve of high resistance driven by voltage. By means of signals from all sensors, ECU outputs a signal to control the opening angle of the valve so that can adjust air flowing to the intake manifold through the by-pass valve, and then correct the idle speed to have engine in normal operation.



Transistor Ignition Coil:

Powered by DC 8~16V, and has 2 terminals connector on the coil. The two terminals are connected to power source and ground respective. Its major component is the highly transferred rate transformer. Its ignition timing is controlled by computer program. From the signals of ignition timing, crank position sensor, throttle valve position sensor, and engine temperature sensor as well as intake temperature sensor, and correspondence with engine speed, then the ECU decides the ignition timing properly by means of controlling of primary current in ON & OFF operation to create the secondary voltage of 25000~30000V. And then, the voltage trigged the spark plug ignition. Such kind of ignition system not only can enhance engine performance to max. but also increase fuel consumption efficiency and improve emission quality.

4. FUEL INJECTION SYSTEM



Intake temperature and pressure sensor:

Powered by 5V DC from ECU. It has 4 terminals on the sensor. One terminal is for power, and 2 terminals are for signal output. And, the rest one is for ground.

The major component of the intake pressure sensor is a variable transistor IC. Its reference voltage is DC 5V, and output voltage range is DC 0~5V.

It is a sensor of combination by both sensing pressure and temperature, and can measure the absolute pressure and temperature in intake process. It also conduct fuel injection quantity correction based on environmental temperature and position level.



Engine temperature sensor:

Powered by 5V DC from ECU, and has 2 terminals connector on the sensor. One terminal is for voltage output and the other one for ground.

Its major component is the thermistor of negative temperature coefficient-NTC. (temperature up, resistance down)

It locates onto the cylinder head. Correspondence with engine coolant temperature change, it transferred to voltage signal and sent to ECU to calculate current temperature. Then, the ECU will correct fuel injection time and ignition timing according to engine warm up condition.



Throttle Valve Position sensor:

Powered by 5V DC from ECU, and has 3-terminal connector on the sensor. One terminal is for power, and one for voltage output, and then the last one is for ground.

Its major component is a highly precious variable resistor. The input voltage range: 5V DC.

It is located on the side of throttle body. By means of the throttle valve rotation to cause voltage change in linear, it provides ECU with current throttle valve openness information. And also, the ECU conducts the most properly fuel injection and ignition timing according to the signal.



Throttle Body:

The throttle body is the air flow adjustment mechanism of the fuel injection. (Its function is likely the carburetor.)

The throttle valve shaft is to turn the throttle valve position sensor in synchronously so the ECU that can detect the throttle valve openness in time.

The guide onto the throttle body is connected to the idle speed air by-pass valve. By means of the ECU to control the idle speed air by-pass valve, air-flow is adjusted by the valve so that stabilizes idle speed.

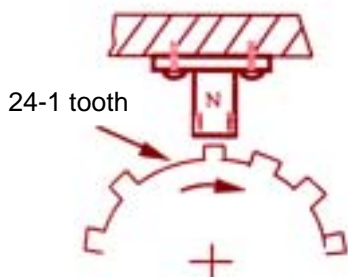

Crank position/rpm sensor:

It does not need power supply, and has 2-signal terminals connector on the sensor.

Its major component is the magnetic pickup coil, and its output voltage range is $\pm 0.8\sim 100V$.

The air gap between the sensor and flywheel must have $.07\sim 1.1mm$. The magnetic sensor is sent an inductive voltage that is created by cutting the magnetic field with the rotation gear (24-1 tooth) onto the flywheel to the ECU. Then, the ECU calculates current engine speed and crank position based on the voltage so that controls fuel injection quantity and ignition timing in properly.

Fuel Lines

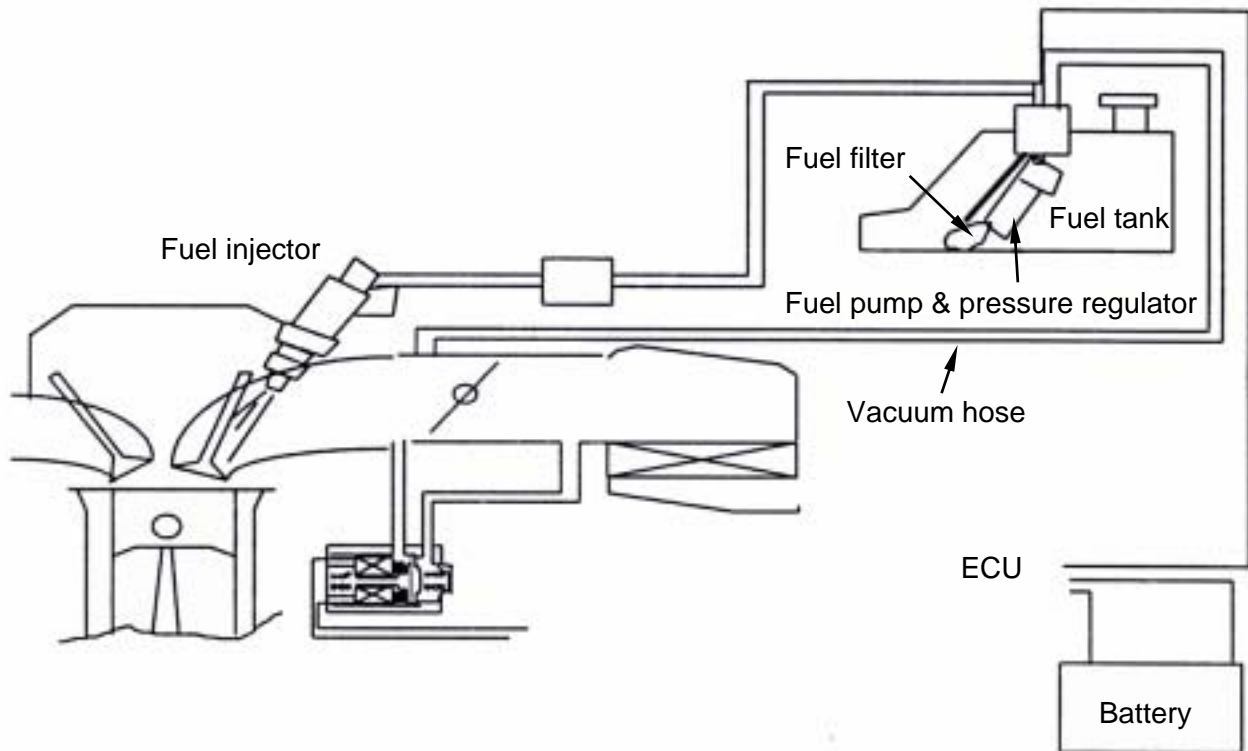
**System Description:**

1. All sensors' signals sent to the ECU firstly after the electrical fuel pump inside the fuel tank key-on. Then, ECU controls the fuel pump relay so let the pump operate. If the engine did not start for 2~3 seconds, then the fuel pump will be turned off to save power. The pressure regulator is to maintain the fuel pressure in 2.5bar, and the fuel injector inject properly fuel quantity according to running conditions and environmental corrective coefficient. When key-off or engine stopped, the fuel pump stops operating.
2. The fuel filter is to filter foreign materials so it has to be replaced regularly.
3. Do not let the starting motor keep running when the engine can not be started in smoothly to cause battery voltage insufficient (under 8V) and the pump will not be operated. The corrective method is to start the engine by connecting a new battery or with foot-lever.

4. FUEL INJECTION SYSTEM

Ignition System

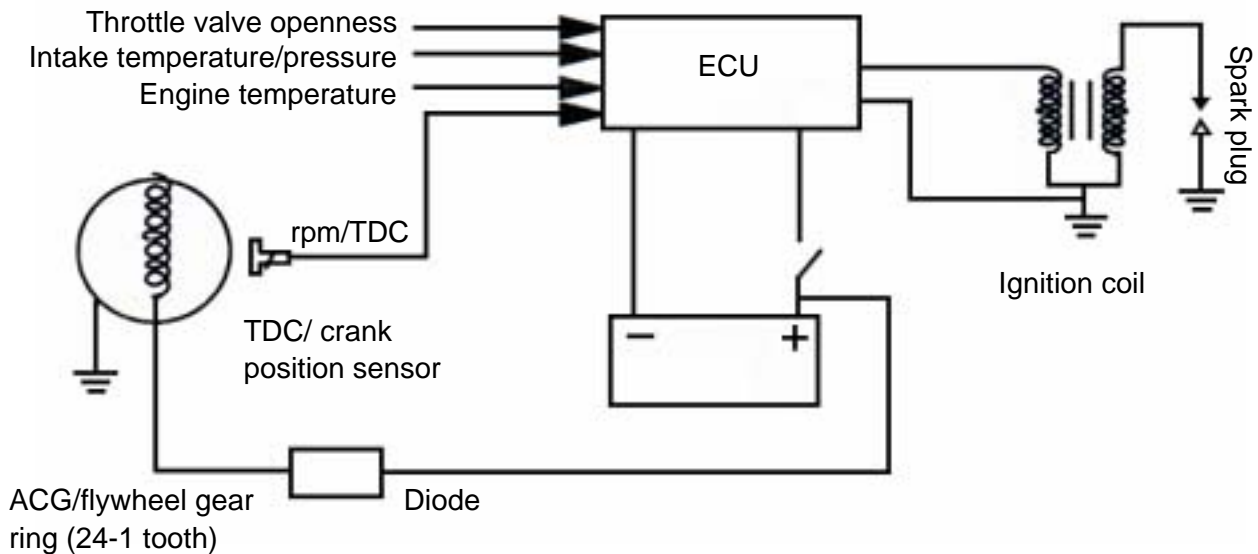

1. Principle of operation:

The engine is equipped with a computerized ignition control system that collects signals from TDC/crankshaft position sensor, throttle position sensor, temperature sensor, and intake temperature as well as pressure sensor. Then, correspondence with engine RPM, this 8-bit micro-computer in the system is to control ignition timing properly. The secondary coil creates 25000~30000V high voltage to ignite the spark plug by means of the transistor to open/close operation of the primary current inside of the computerized system. Such operation not only have max engine performance output but also increases fuel consumption ratio.

2. Specification

- 1) Ignition timing: BTDC 13°/1600RPM
- 2) Spark plug: NGK CR8E
Gap: 0.7~0.8mm
- 3) ACG
Pulse generator coil: 120 + 10% Ω (G/W-Y)
- 4) Ignition coil:
Primary circuit: 0.63 \pm 0.03 Ω (20)
- 5) Battery:
Type: YTX9A-BS.8Ah
Capacity: 12V 8Ah

Crank Position Sensor

The magnetic field type sensor is to induct a voltage signal to calculate engine speed with ACG gear ring (24-1 tooth).

There is one tooth in every 15 degree on the gear ring. But, one of teeth is flatted to be TDC base.

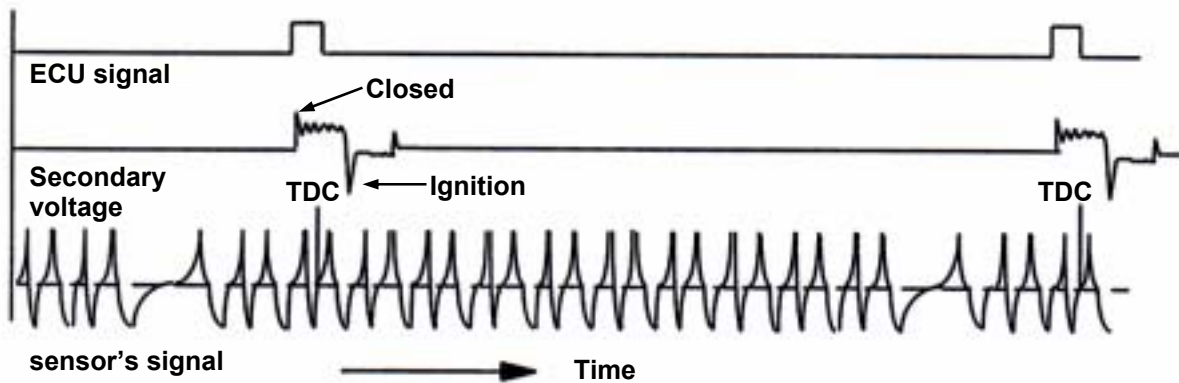
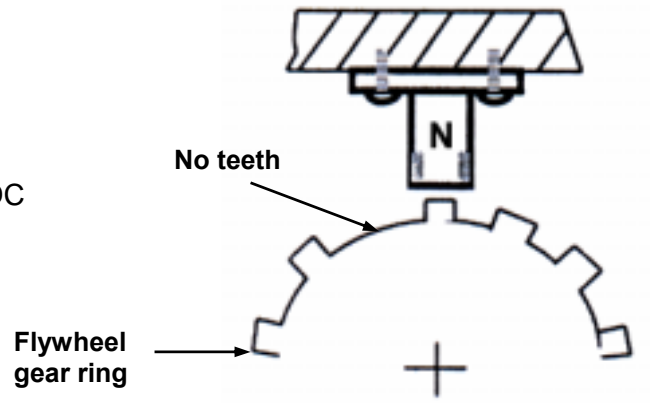

Description:

The ECU that received all sensors' signals to control the throttle valve openness with PWM so that can adjust air-flow into the by-pass valve of the intake manifold. And then adjust idle speed and have a stable and normal running engine.

1. When engine starting---the by-pass valve open for a while to increase air-flow and then enhance engine idle speed to prevent from unstable engine running and misfired within initial starting.
2. Warm-up---when engine oil is in low temperature condition, the by-pass valve adjusts air-flow according to engine temperature (engine oil temperature) so that have a fast idle speed.
3. Speed Decreasing---with the ECU controlling, the by-pass valve also corresponds with acceleration operation to provide intake manifold with proper air-flow quantity. Such operation will let engine rpm reduce slowly to prevent from engine misfired, negative pressure in intake manifold increasing, and then to reduce HC emission.

4. FUEL INJECTION SYSTEM

Temperature Sensor

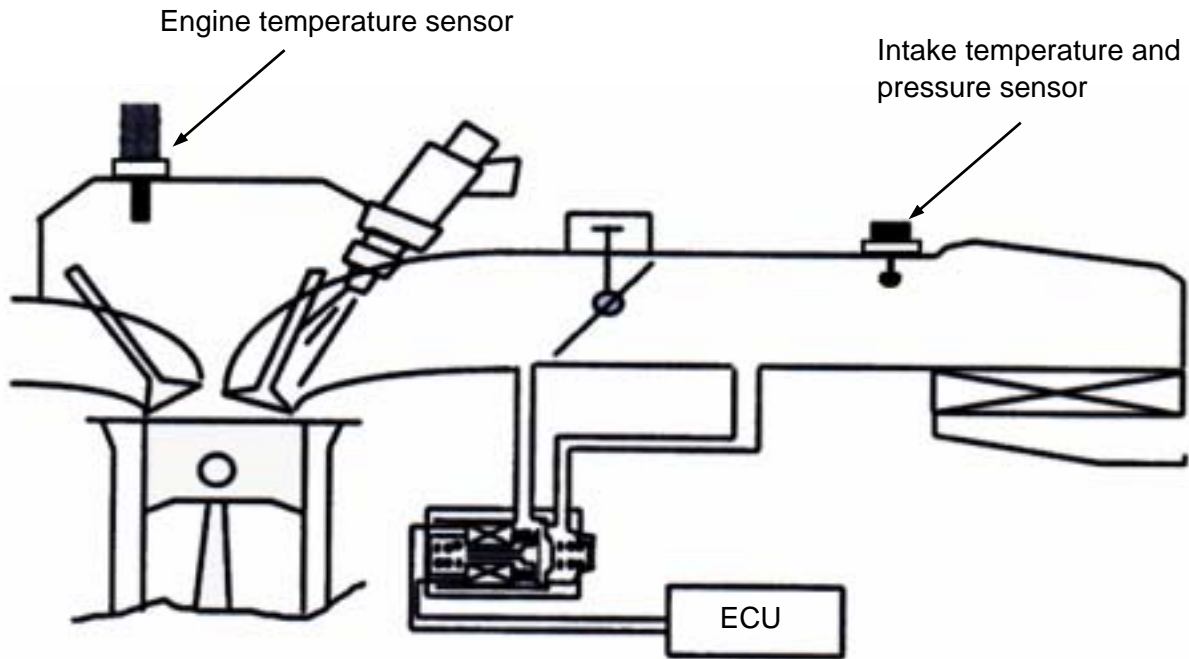

Engine oil temperature sensor: According to the semiconductor's variable character, the sensor detects the change of engine oil and metal wall and then transferred into a voltage signal sending to the ECU. Then, the ECU corrects fuel injection and ignition timing.

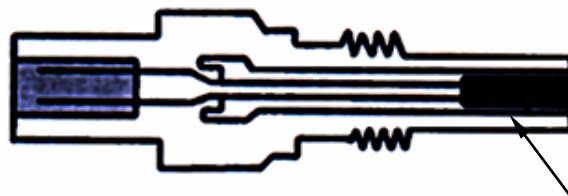

NTC-Negative Temperature Coefficient Resistor

Intake temperature and pressure sensor: a sensor that is combined both pressure and NTC can detect the absolute pressure and temperature in the intake manifold, and then provides the ECU with signal for adjustment fuel injection quantity based on environmental temperature and location level.

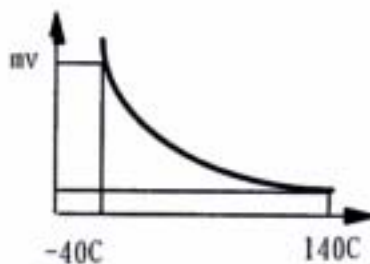

Air By-pass Valve

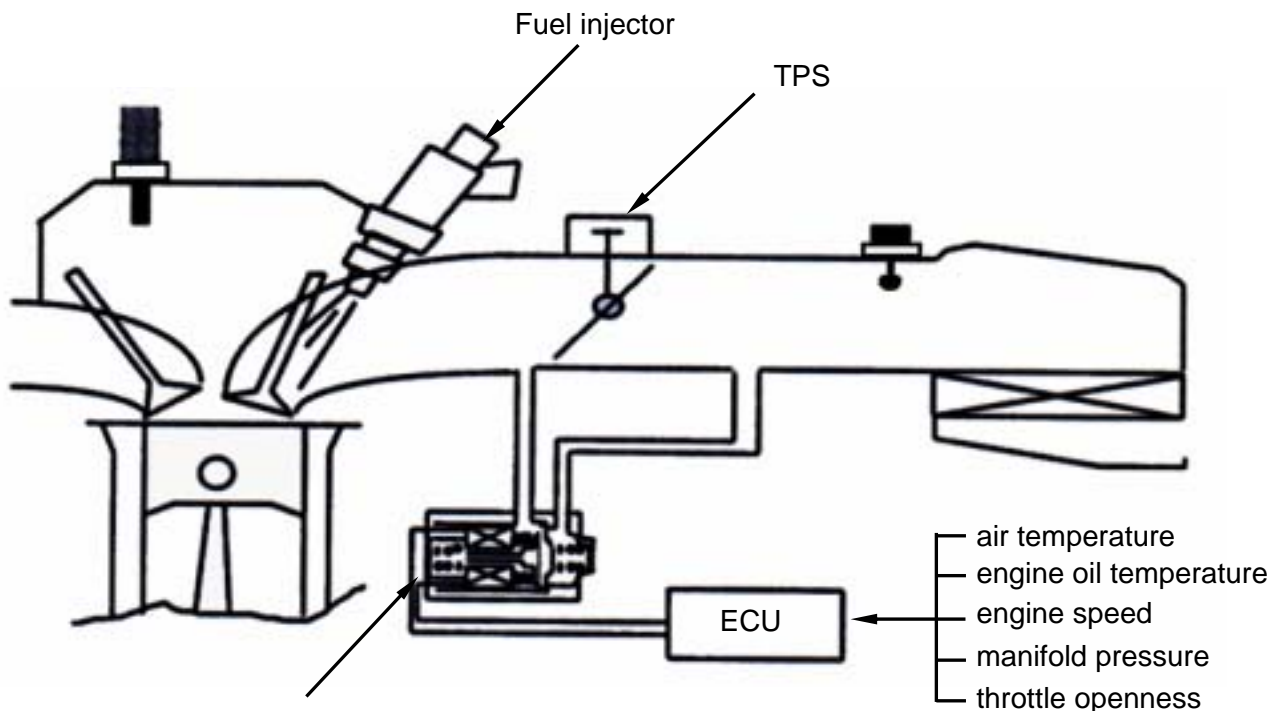

Description: Air by-pass valve

The ECU that received all sensors' signals to control the throttle valve openness with PWM so that can adjust air-flow into the by-pass valve of the intake manifold. And then adjust idle speed and have a stable and normal running engine.

1. When engine starting---the by-pass valve open for a while to increase air-flow and then enhance engine idle speed to prevent from unstable engine running and misfired within initial starting.
2. Warm-up---when engine oil is in low temperature condition, the by-pass valve adjusts air-flow according to engine temperature (engine oil temperature) so that have a fast idle speed.
3. Speed Decreasing---with the ECU controlling, the by-pass valve also corresponds with acceleration operation to provide intake manifold with proper air-flow quantity. Such operation will let engine rpm reduce slowly to prevent from engine misfired, negative pressure in intake manifold increasing, and then to reduce HC emission.

Fuel Injector

The 2-hole fuel injector provides two intake valves with one fuel injection so that can reduce HC emission. A short mounted nut can lock the fuel injector easily and receive fuel from the fuel pump. The mounting bracket can limit the fuel injector rotation in left or right motion. The fuel injection quantity is controlled by the ECU signal. The fuel pressure regulator can keep pressure difference in between fuel pressure and manifold vacuum around 2.5bar by means of diaphragm and spring. Therefore, with such operation, the fuel injector can control its fuel injection quantity by injection width (time) under different engine loads.

Fuel Pump

The electrical fuel pump is powered by battery and controlled by the ECU for on or off. The pump can output 14 l/h fuel quantity in 2.5 bar.

4. FUEL INJECTION SYSTEM

Fuel Tank

Removal of fuel pump/pressure control valve/fuel sender

Open the seat cushion.

Remove the luggage assembly. (bolt x 4, screw x 1)

Remove the rear carrier. (bolt x 4)

Remove both the left and right body covers. (screw x 4)

Remove the rear lamp. (screw x 4)



Disconnect the connectors of fuel pump relay, diode, and fuel sender.

Remove the fuel cut valve. (screw x 4)

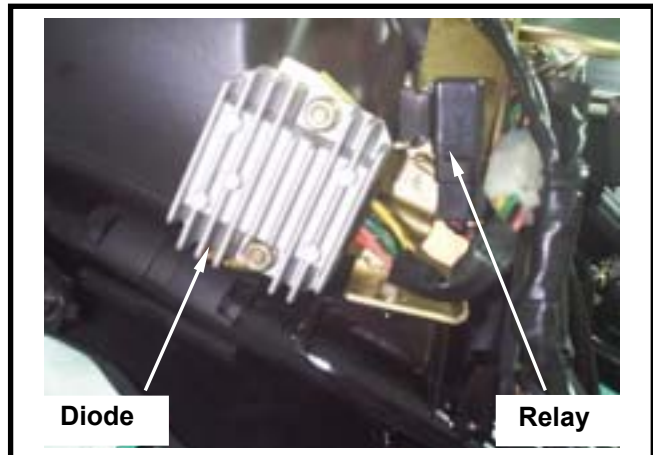

Removal of fuel pump/fuel sender

Slightly knock the fuel pump mounting plate to let the plate out of locker.



Remove the mounting plate and the fuel pump body.

Caution

The fuel pump mounting plate is easily deformed as removing the plate. Thus, in order to prevent from fuel leaking, check it in detailed and replace it with new one if necessary.



Remove the rubber oil seal.

Installation of the fuel pump and the fuel sender

Install them in reverse procedure of removal.

⚠ Caution

The oil seal of fuel pump can not be omitted, deformed or damaged.

⚠ Caution

Do not bent the fuel sender floating arm.
Do not fill out too much fuel in the tank.
The mark must be aligned as installing the fuel pump mounting plate.

The fuel sender check. (refer to chapter 16-Electrical Equipment)

Removal of fuel tank

- Open the seat cushion.
- Remove the luggage assembly. (bolt x 4, screw x 1)
- Remove the body cover. (screw x 4)
- Remove the rear lamp assembly. (screw x 4)
- Disconnect the connectors of fuel pump relay, regulator, and fuel sender.
- Remove the fuel pump.
- Remove the fuel cut valve.

Remove the fuel inlet. (bolt x 2)

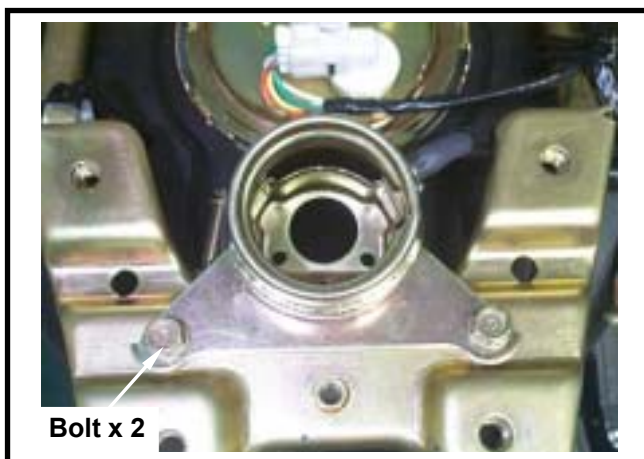

4. FUEL INJECTION SYSTEM

Remove the fuel tank mounting bracket. (bolt x 4)



Remove the fuel tank.
Loosen the fuel inlet clamber and then remove the fuel inlet and the connection hose.
Remove all hoses from the pressure regulator.



Installation

Install the fuel tank in reverse procedure of removal.

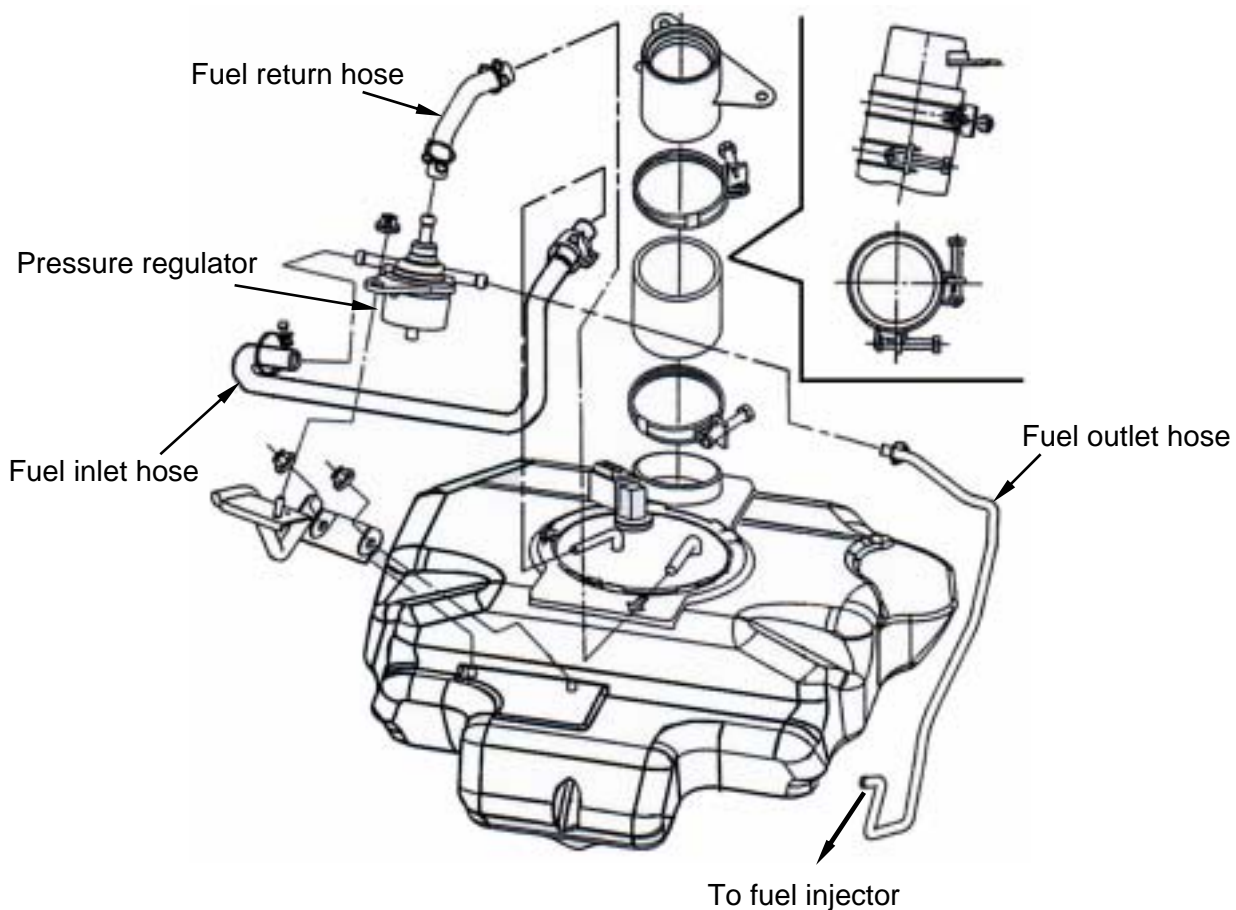



4. FUEL INJECTION SYSTEM

Air Cleaner

Remove the air cleaner cover. (screw x 6)

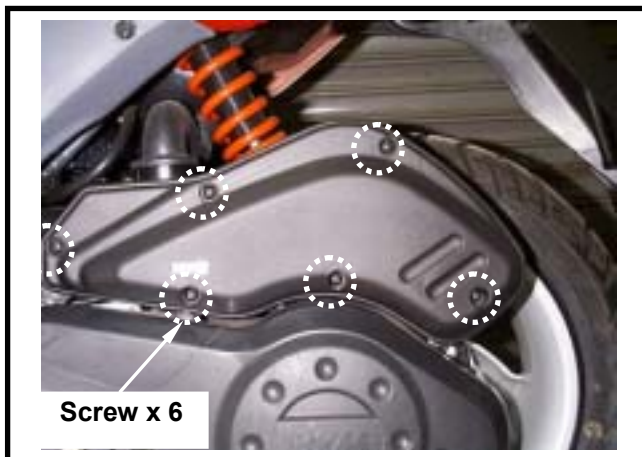

Remove the air cleaner assembly.



Installation:

Install the air cleaner in reverse procedure of removal.

Application of fuel injection system diagnosis

Open the front luggage cover.

Connect the ECU connector and then turn on the main switch.

Operate the diagnosis according to its operation instruction.



4. FUEL INJECTION SYSTEM

Trouble Diagnosis & Solutions Of EFI

Judgment of Flash Code

When the engine might have problem and also no tester to detect, the problem can be detected by reading the flash times of CHK lamp on the odometer. And then, the motorcycle is warned what kind of problem had occurred by means of the solution priority lamp of the tester operation message table, or the FLASH CODE.

There are descriptions for the two ways below:



To show “the solution priority”

Turn the KEY ON directly, and the CHK lamp goes up for 2 seconds. Then, the CHK lamp will lit up by 3 types for showing the priority of problem solution so that reminds the rider to have the motorcycle conduct troubleshooting.

The 1st Priority: the CHK lamp lit up by every 0.3 second.

The 2nd Priority: the CHK lamp lit up continuously.

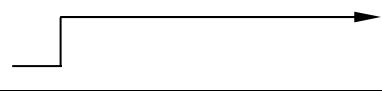
The 3rd Priority: the CHK lamp is not lit up.

Priority	Lit up types
1	ON  OFF
2	ON  OFF
3	ON  OFF

To show “FLASH CODE”:

Before turning the KEY ON, wide open the throttle valve. Then, turn the KEY ON, the CHK lamp lit up for 2 seconds and off. But, the CHK lamp will lit up again after off 3 seconds. In the means time, close the throttle valve. Finally, it is to determine what problem occurred based on the flash time of CHK lamp.

Before show up, CHK lamp will lit up for 4 seconds firstly. Then, according to the lamp flash times (every 0.5 second), the problem will be determined by comparing with the operation message table. If there has the 2nd problem in the system, the CHK lamp will have flash operation again after its lit up for 4 seconds.

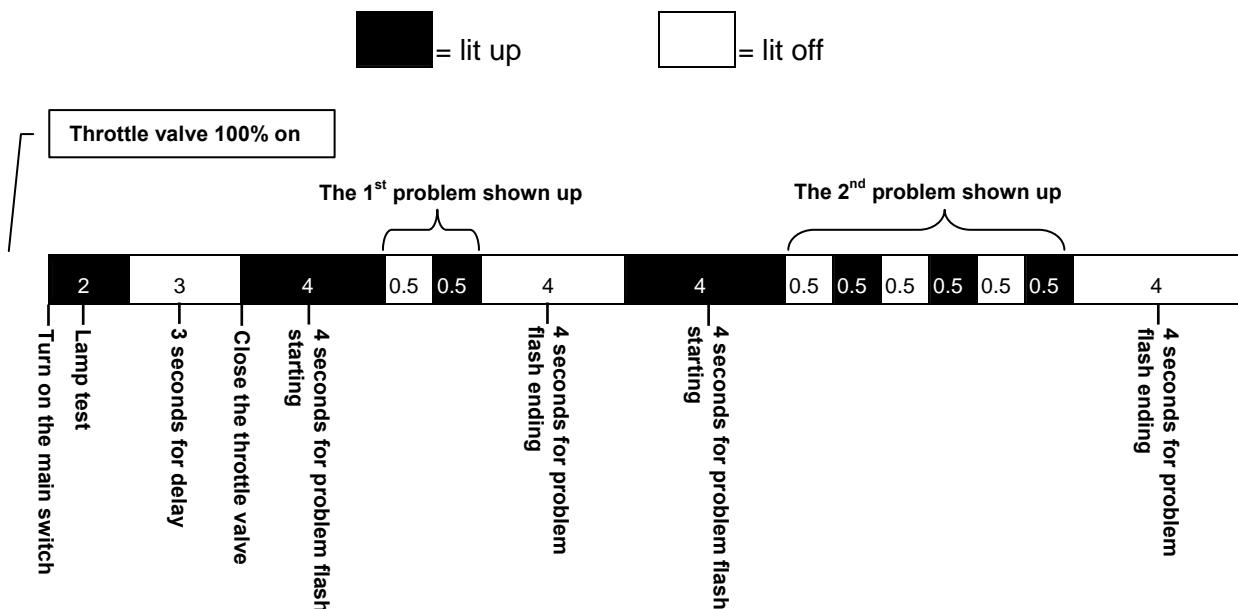

Error Code Message and Solution Operation

DTC Code	Solution Priority	Flash code	Message	Solution Operation
P0217	1	1	Engine temperature overheat	<ol style="list-style-type: none"> 1. Stopping the motorcycle immediately, and solve it with priority 2. Check if the lubricant system for abnormal? 3. Is the ignition or fuel supply system in normal? 4. Has the engine shown burnt? 5. Make sure if the engine temperature sensor is in normal. 6. Make sure if the connector is in normal.
P0335	2	2	Crank position sensor	<ol style="list-style-type: none"> 1. Check if the connection of the crank position sensor is open-circuit. 2. Check if the air gap between the sensor and gear tooth is within specification. 3. Check if the crank rotation is run-out. 4. Check if the sensor is in normal according to the new component replacement procedure.
P1120	2	3	Poor contact of the throttle valve sensor	<ol style="list-style-type: none"> 1. Connect the diagnosis and reset the throttle valve position. Make sure if the idle speed position is within specified range. 2. Make sure if the wire circuit of the throttle valve position sensor is loosen or short. 3. Check if the openness of idle speed by-pass valve is within specification. (40~100%) 4. Adjust the idle speed CO value to specified range. (0.5%~2.0%) 5. If this problem symptom still existing, check if the throttle position sensor (TPS) is in normal according to the new component replacement procedure.
P1121	2	4	Application malfunction of the throttle position sensor	<ol style="list-style-type: none"> 1. Make sure if the wire circuit of the throttle valve position sensor is loosen or short. 2. If this problem symptom still existing, check if the throttle position sensor (TPS) is in normal according to the new component replacement procedure.
P1122	2	5	Rotation speed malfunction of the throttle position sensor	<ol style="list-style-type: none"> 1. Make sure if the wire circuit of the throttle valve position sensor is loosen or short. 2. If this problem symptom still existing, check if the throttle position sensor (TPS) is in normal according to the new component replacement procedure.
P0560	1	6	Abnormal battery voltage warning	<ol style="list-style-type: none"> 1. Make sure if the battery voltage is too low or high (below 10V or exceed 16V) 2. Make sure if the ACG generator charging system circuit is short or abnormal. 3. Make sure if the 15th terminal on the ECU to battery positive post is short. 4. Make sure if the battery is in normal. Replace it with new if the battery is out of order.
P0110	2	7	Abnormal intake temperature sensor	<ol style="list-style-type: none"> 1. Make sure if the sensor's resistor is in normal (20 2353~2544Ω). 2. Make sure if the sensor's wire is in open-circuit (the 22th terminal on ECU). 3. Make sure if the sensor is normal according to the new component replacement procedure.
P0410	2	8	Abnormal air by-pass valve	<ol style="list-style-type: none"> 1. Make sure if the sensor's resistor is open or short circuit. 2. Make sure if the sensor's wire is in open-circuit (the 13th terminal on ECU) 3. Make sure if the by-pass valve is normal according to the new component replacement procedure.

4. FUEL INJECTION SYSTEM

DTC Code	Solution Priority	Flash code	Message	Solution Operation
P0505	2	9	Application range abnormal of the air by-pass valve	<ol style="list-style-type: none"> 1. Check if the openness of idle speed by-pass valve is within specification. (40~100%) 2. Make sure if the idle speed valve openness is in normal. (stuck or poor adjustment of air screw) 3. Make sure if the intake manifold is leaking.
P0251	2	10	Abnormal fuel injector	<ol style="list-style-type: none"> 1. Make sure if the fuel injector resistor is within specification. (14.5 , 20) 2. Make sure if the connector or wire is in open-circuit. (the 3rd terminal of ECU) 3. Make sure if the fuel injector power supplied is in normal. (12~15V)
P0350	2	11	Abnormal ignition circuit	<ol style="list-style-type: none"> 1. Make sure if the ignition coil resistor is within specification. (0.63 , 23) 2. Make sure if the connector or wire is in open-circuit. (the 12th terminal of ECU) 3. Make sure if the ignition coil power supplied is in normal. (12~15V) 4. Make sure if the ignition coil is normal according to the new component replacement procedure.
P0230	2	12	Abnormal fuel pump relay	<ol style="list-style-type: none"> 1. Make sure if the connector or wire is in open-circuit. 2. Replace with new relay to make sure if this abnormal is disappeared.
P0219	2	13	Engine over-speeding	<ol style="list-style-type: none"> 1. Engine speed exceed safety limit. Decreasing the speed and then the DTC code disappeared. 2. Check if the CVT belt is broken.
P1560	2	14	Abnormal 5V driving voltage	<ol style="list-style-type: none"> 1. Make sure if the 18th terminal of ECU is 5V. 2. Make sure if the sensor's power voltage is 5V. (The 16th & 18th terminals) 3. Replace the ECU and confirm again.
P0700	2	15	High RPM warning for starting engine	<ol style="list-style-type: none"> 1. If the engine speed is exceed 300rpm as starting, in order to prevent run-away, the ECU will decrease engine speed or stop the engine. 2. Rider should avoid to starting engine with WOT suddenly. 3. Check if acceleration cable is stuck. Re-set the idle speed adjustment position.
P0115	2	16	Abnormal engine temperature sensor	<ol style="list-style-type: none"> 1. Make sure if the sensor's resistor is within specification. (25 , 10319~11981) 2. Make sure if the sensor's wire is in open-circuit. (the 9th terminal of ECU) 3. Make sure if the sensor is normal according to the new component replacement procedure.
P1561	2	17	Abnormal engine temperature gauge	
P0650	3	18	Abnormal warning lamp	<ol style="list-style-type: none"> 1. Check if the warning lamp is burnt. 2. Check if the warning lamp circuit is open. (the 4th terminal of ECU)
P1410	2	19	Adjustment of CO	
P0105	2	20	Abnormal MAP sensor	<ol style="list-style-type: none"> 1. Make sure if the sensor's voltage is within specification. (101kpa, 3.925V) 2. Check if the sensor circuit is open. (the 8th terminal of ECU) 3. Make sure if the sensor is normal according to the new component replacement procedure.

EFi Data scan Operation Manual

A. DTC Codes Retrieved by Data Scan

Description:

When a problem comes out, with the Data Scan to diagnosis the problem and solve it.

Method:

1. Stop the engine and do not turn on the ignition switch.
2. Open the front grove cover, and connect the connector on the motorcycle with the Data Scan's connector.
3. The menu will show connection and software & hardware versions.
4. Press "Enter" to enter main menu.
5. Move the key to " read DTC" and then press "Enter" key.
6. The menu will show 3 functions, 1) Current problem searching 2) Just occurred problem searching, and 3) past problem searching, for selection.
7. When selecting the 1) & 2) functions, then it will search the DTC code of current & just occurred problems.
8. Compare with the DTC code table, and conduct the troubleshooting procedure.

B. EFI Data Scan Introduction





4. FUEL INJECTION SYSTEM

C. Data Scan Function Menu

- 1. P1120: Throttle position sensor connection problem
- 2. P0560: Abnormal battery voltage
- 3. P0700: Starting speed exceeds CVT matching speed

- 1. Problem searching.
- 2. Just occurred problem searching,
- 3. past problem list

The DTC codes can be erased only under turn on the ignition switch and engine stopped.

PIM1 ECU

- 1 Read DTC
- 2 Clear DTC
- 3 Data Stream
- 4 Idle CO adjustment
- 5 Activation
- 6 Sensor Waveform
- 7 Identification

Monitor menu (1/8)

- Engine speed 3700rpm
- Intake temperature 35 Engine

With the narrow mark to adjust value.

▲ +1
- 10 ◀ ▶ +10
▼ -1

Adjustment range does not exceed ±75.

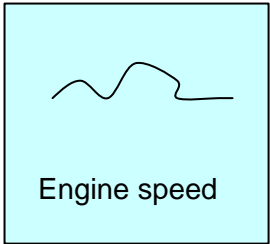

- 1. Re-set throttle position. (the command must be done after adjusting the idle speed screw or replacing the throttle body.)
- 2. Carbon deposited time re-set. (the command must be done after cleaning the throttle body or replaced new one ECU.)

D. Operation Steps & Menu Function Description

1. Connect the Data Scan's connector onto the specified signal connector of the EFI system on the motorcycle.
2. Turn the ignition switch on and then the LCD monitor goes on and show "SANGYANG Motor Co." as fig 1.
3. Press the "ENTER" key to continue, the monitor goes show "CONNECTING" as fig 2.



Fig 1



Fig 2

When press "ENTER" key, it shown 2 pages (1/2~2/2) of motorcycle data. To select function menu with the ◀ ▶ cursor.

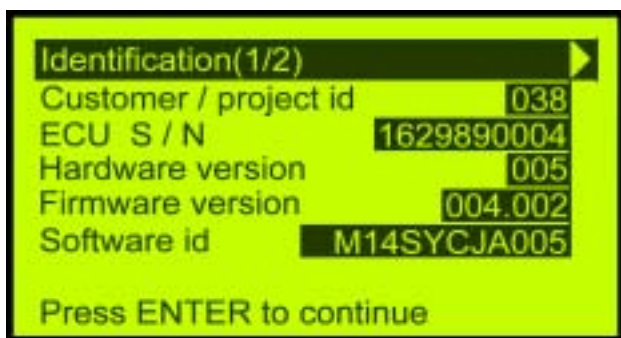

Fig 3

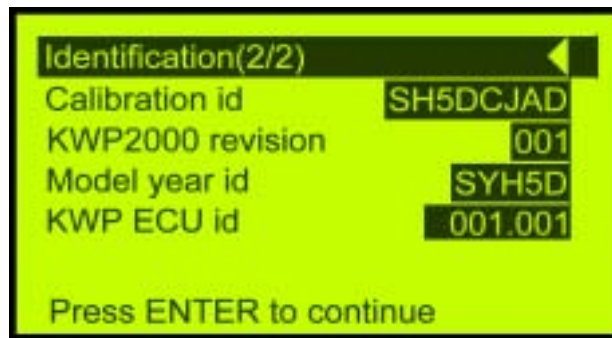

Fig 4

4. In the (2/2) menu, press "ENTER" and then enter into the main menu. (as fig 5)
Then with the ▲ ▼ cursor to select main menu, and then press "ENTER" to conduct 1~7 function.
Each functions' menu is described as below:

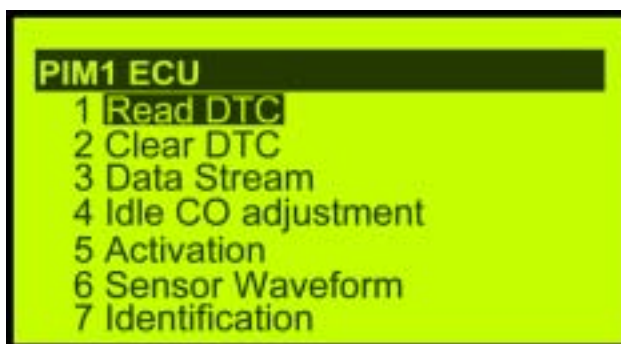

Fig 5

4. FUEL INJECTION SYSTEM

When selecting the “1. retrieving DTC code” (LCD background changed into black), and press “ENTER”, then there have 3 sub-functions can be selected.

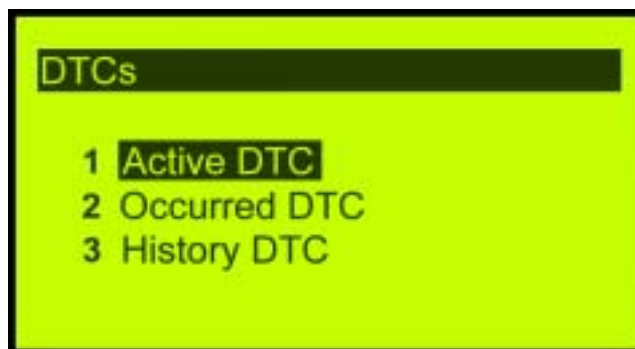

Fig 6

With the ▲▼ cursor to select “1. active DTC codes” (LCD background changed into black), press “ENTER”, and then enter into problem searching menu & verify if problem occurred right now. The menu will show problem symptom when problem have been detected. Then, conduct repairing procedure for the problem. However, if there is no DTC codes been shown on the menu, it means the EFI system is in normal. Press “EXIT” key to back to the main menu.

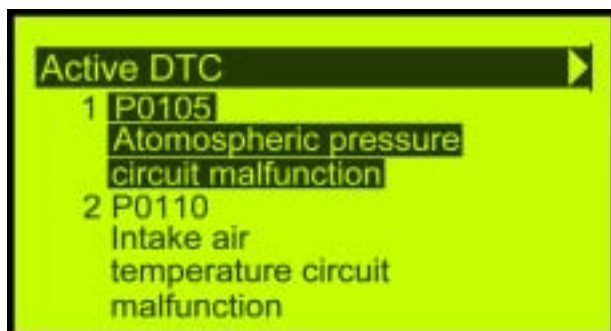

Fig 7

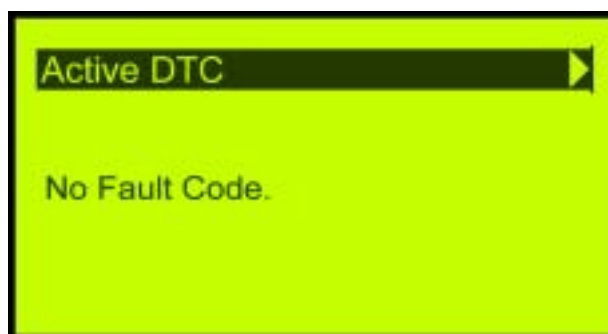

Fig 8

With the ▲▼ cursor to select “2. occurred DTC codes” (LCD background changed into black), press “ENTER”, and then enter into problem record menu. (as fig 9)

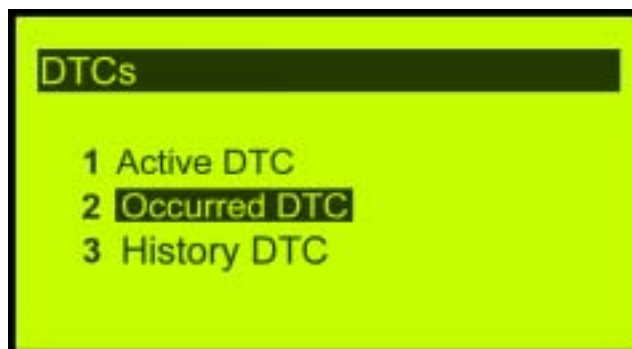

Fig 9

To verify if there has problem occurred in past. When the menu record shows the past problem record, it will show the problem symptom (as fig 10). Then, suggestion to erase the DTC codes. (please refer to DTC codes Erase on page 28). However, if there is no problem shown on the menu, it means that there is no problem record in past. Press “EXIT” key to back to the main menu.

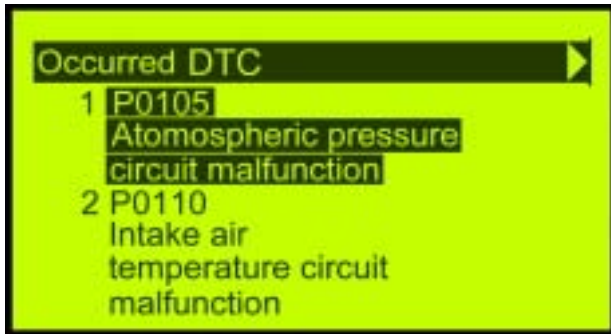

Fig 10

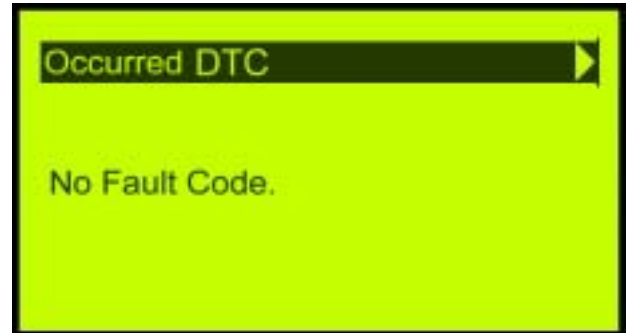

Fig 11

With the ▲▼ cursor to select “3. history DTC codes” (LCD background changed into black), press “ENTER” , and then enter into problem record menu. (as fig 12)

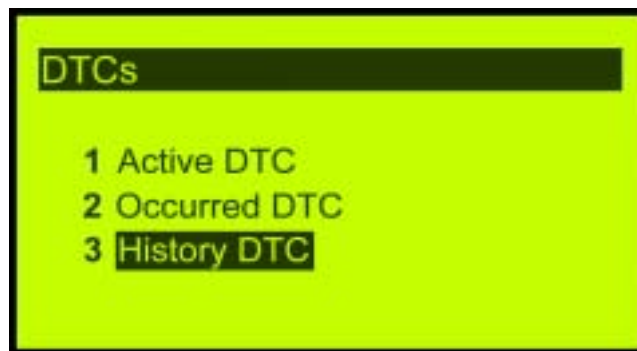

Fig 12

When the menu record shows the history problem record, it will show the problem symptom (as fig 13). Then, suggestion to erase the DTC codes. (Please refer to DTC codes Erase on page 37). However, if there is no history problem record shown on the menu, it means that there is no problem record in history. Press “EXIT” key to back to the main menu.

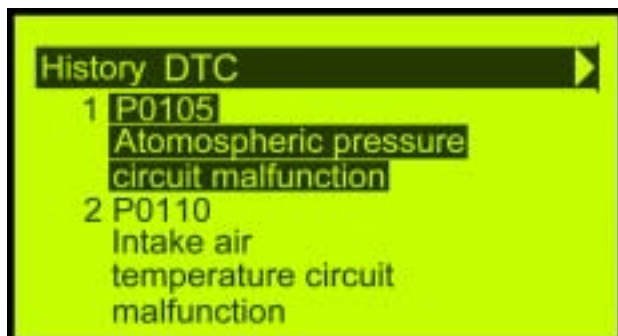

Fig 13

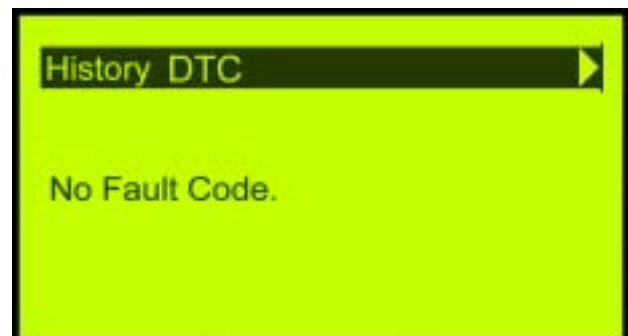

Fig 14

4. FUEL INJECTION SYSTEM

Remarks:

- a. Current DTC codes: It means that the problem onto EFI system is occurring. When the problem is solved, the recorded will disappear.
 - b. Past DTC codes: It means that the problem onto the EFI system just occurred. The DTC codes are recorded. Even the Current problem are solved and its DTC codes also have been erased, the DTC codes still be recorded into the past DTC codes until turning off the ignition switch so that the past DTC codes can be erased.
 - c. History DTC codes: It means that the problem onto the EFI system had been occurred. So, the DTC codes were recorded. Unless with command to erase the problem history record, the problem record will be kept continuously.
5. With the ▲▼ cursor to select “2. DTC Code Erase” (LCD background changed into black), (as fig 15), press “ENTER” key to erase the DTC codes (as fig 15-1, 16, 17). This function can be conducted only when the ignition switch is turned on and the engine stopped. Press “EXIT” key to back to the main menu.

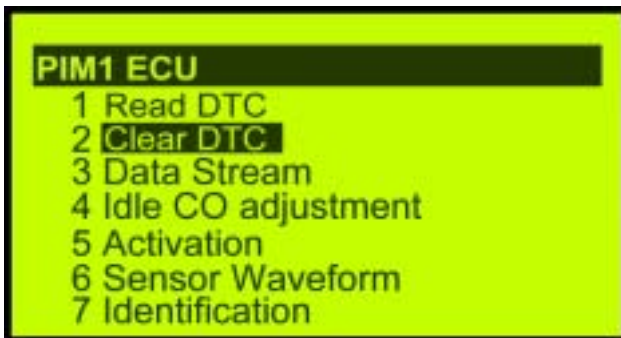

Fig 15

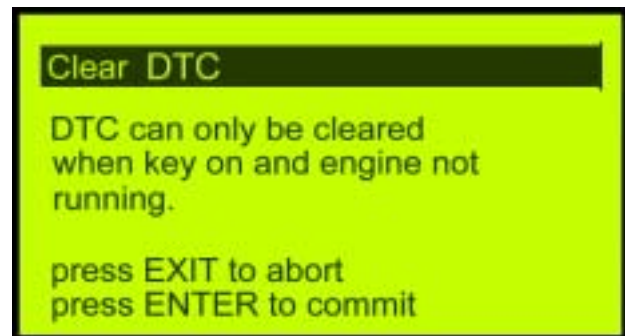

Fig 15-1

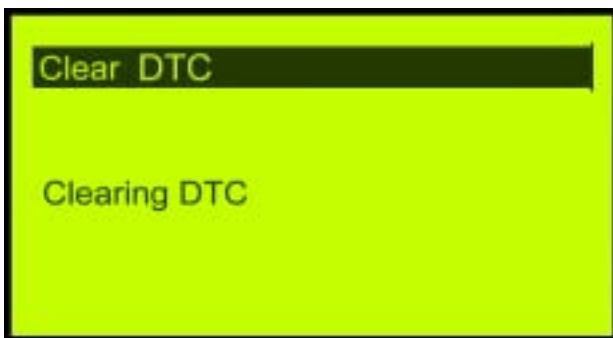

Fig 16



Fig 17

6. With the ▲▼ cursor to select “3. Data analysis” (LCD background changed into black), (as fig 18), press “ENTER” key to enter into EFI data analysis. There are 8 instantly dynamic data values shown on the menu. (1/7~7/7) (as fig 19, 20, 21, 22, 23, 24, 25, 26) Select desired menu with ◀ ▶ cursor.

As the fig 19 (1/8) shown, the menu provides with 3 set dynamic values of engine rpm, intake temperature & sensor’s voltage, and engine temperature & sensor’s voltage.

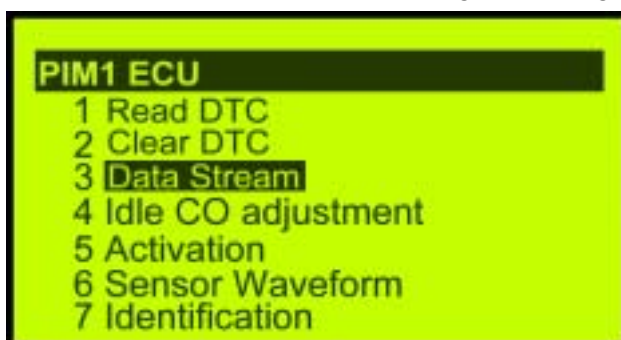

Fig 18

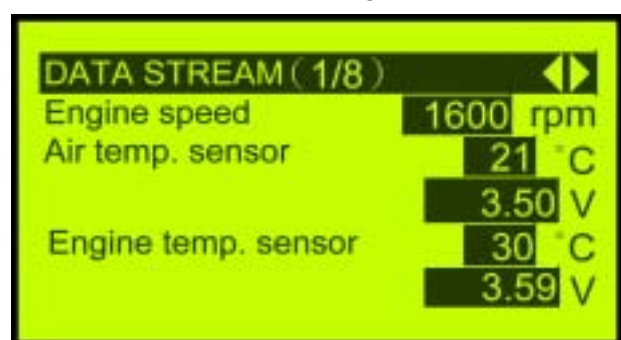

Fig 19

As the fig 20 (2/8) shown, the menu provides with 3-set dynamic values of engine rpm, atmosphere pressure & sensor's voltage, and throttle valve opening & sensor's voltage. As the fig 21 (3/8) shown, the menu provides with 3-set dynamic values of engine rpm, CO voltage meter, battery voltage, and sensor's voltage.

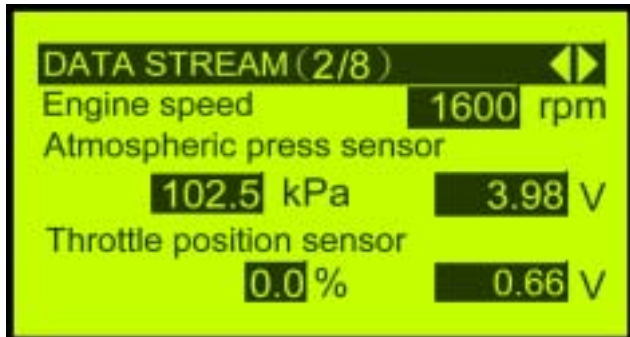

Fig 20

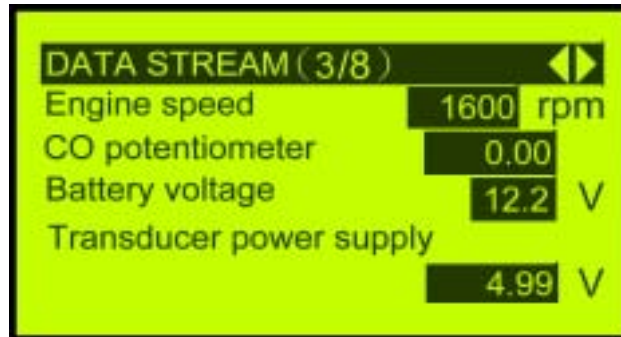

Fig 21

Description:

CO voltage meter: it is designed onto the ECU. This model does not has this function.
 Battery voltage: it means that the ECU receives voltages from the terminals of power supply, fuel injector, transistor ignition coil, and fuel pump.
 Sensor voltage supply: it means that DC 5V supplied by the ECU and detected voltage. (standard voltage value: $5V \pm 0.5\%$)

As the fig 22 (4/8) shown, the menu provides with 4-set dynamic values of engine rpm, injection timing, ignition timing, and ignition charging timing.

Description:

Injection timing: It means that the fuel injector opening times controlled by the ECU. i.e. the fuel injection quantity.
 ignition angle: It means that the ignition angle (timing) for the engine controlled by the ECU.
 ignition charging timing: It means that the charging timing (ignition energy) set by the ignition transistor.

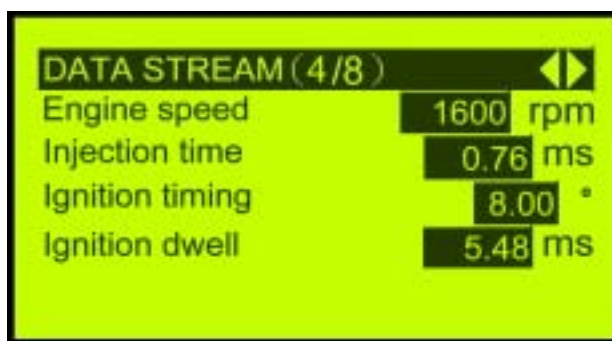

Fig 22

4. FUEL INJECTION SYSTEM

As the fig 23 (5/8) shown, the menu provides with 4-set dynamic values of engine rpm, initial position voltage of throttle valve idle speed, idle speed target value, and idle speed CO corrective value.

Description:

initial position voltage of throttle valve idle speed: It means that the ECU memorizes the idle speed voltage from the first time of throttle position sensor. This value can be a reference for the throttle position sensor damaged.

idle speed target value: It means that the idle speed target value set by the ECU based on current engine temperature and intake temperature.

idle speed CO corrective value: Based on CO value of the engine emission, it corrects the air-flow of idle speed air by-pass valve.

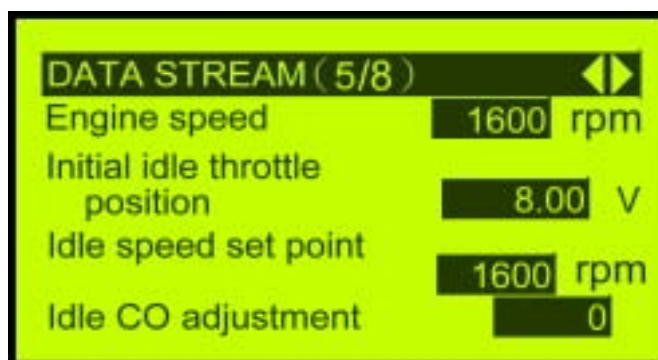

Fig 23

As the fig 24 (6/8) shown, the menu provides with 4-set dynamic values of engine rpm, accumulated running time, PWM output of temperature gauge, and idle speed valve opening.

Description:

accumulated running time: It means that the ECU's inner timer starts to count the ECU operation time at every time to turn on the ignition switch, even the engine does not start, and until turn off the ignition switch.

PWM output of temperature gauge: this model does not has this function.

idle speed valve opening.: It means that the opening of air by-pass valve at current idle speed.

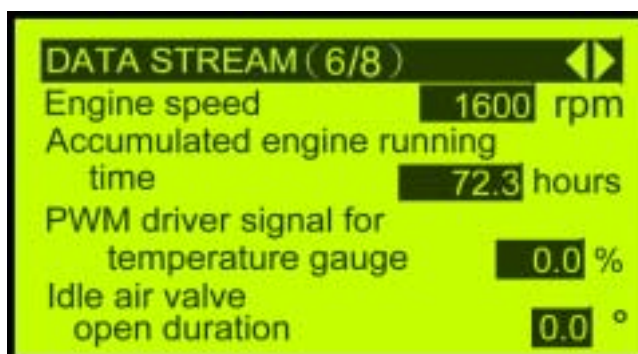

Fig 24

As the fig 25 (7/8) shown, the menu provides with 2-set dynamic values of fuel pump condition and manual TPI initialization.

Description:

Fuel pump condition: It means the ON & OFF condition of current fuel pump.

manual TPI initialization: It means the action status of the manual TPI initialization.

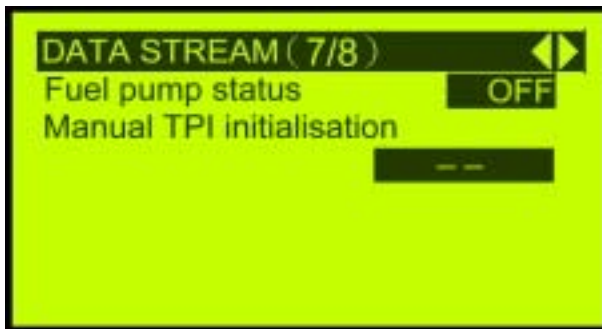

Fig 25

As the fig 26 (8/8) shown, the menu provides with 2-set dynamic values of CO deposit time and CO deposit time reset value.

Description:

CO deposit time: It means that the ECU inner timer starts to count the engine throttle body used time.

CO deposit time reset value: It means that the engine inner timer starts to reset the engine throttle body used time. When you replaced the new one ECU.

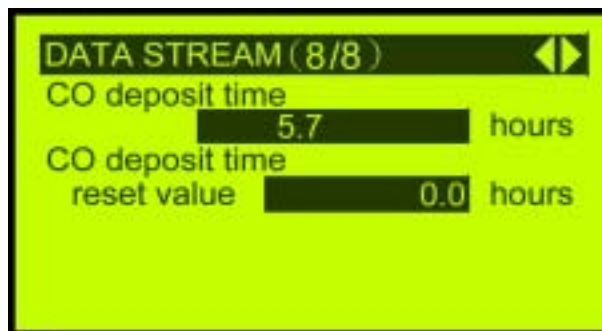

Fig 26

7. When you do not want to check the data analysis above, press “EXIT” key to back to the “4. Idle speed CO adjustment” (LCD background changed into black) (as fig 26) on the main menu. Press “ENTER” key to enter into idle speed CO adjustment. (as fig 27) With the ▲ ▼ and ◀ ▶ cursors to adjust the idle speed CO value.
 Micro adjustment: Press ▲ for one time then +1, but press ▼ for one time then -1.
 Macro adjustment: Press ▶ for one time then +10, but press ◀ for one time then -10.
 After adjustment, press “EXIT” key to back to main menu.

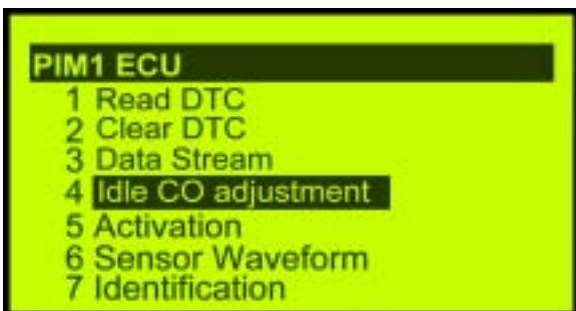

Fig 26

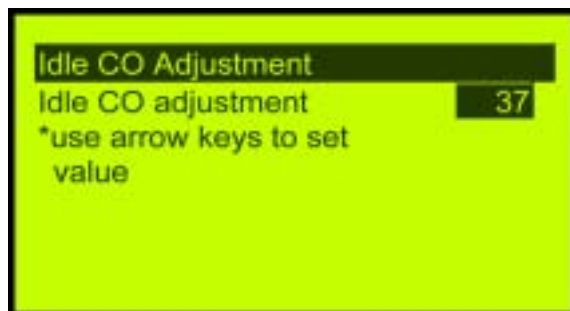

Fig 27

4. FUEL INJECTION SYSTEM

8. With the ▲▼ cursor to select “5 operation test” function, press “ENTER” key to enter into “5. re-set/Zero setting command” main function menu. (as fig 28)

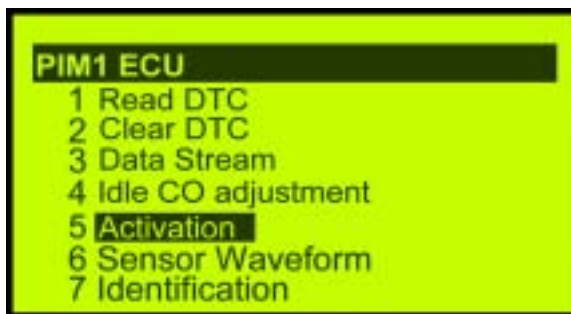

Fig 28

With the ▲▼ cursor to select “1. Reset TPI adaption” or “2. Re-set CO deposited time” function. (as fig 29, 30, 31, 32, 33, 34) (Note: Do not enter this menu if not necessary.)

Description:

1. Reset TPI adaption: After replaced the throttle body with new one or idle speed adjustment screw had been removed, this command has to be conducted.
2. Reset CO deposit time: After clean carbon deposition on the throttle body or replaced it, and replaced the ECU with new one, but without clean or replaced the throttle body, this command has to be conducted.

Press ENTER key to left this set up function menu.

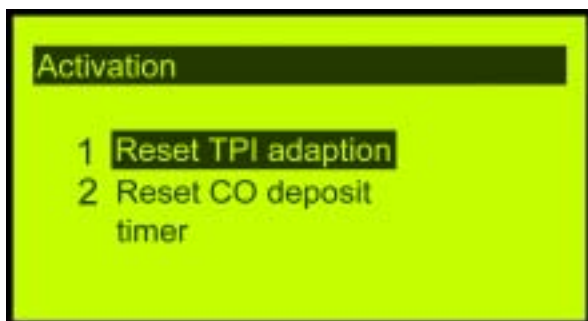

Fig 29

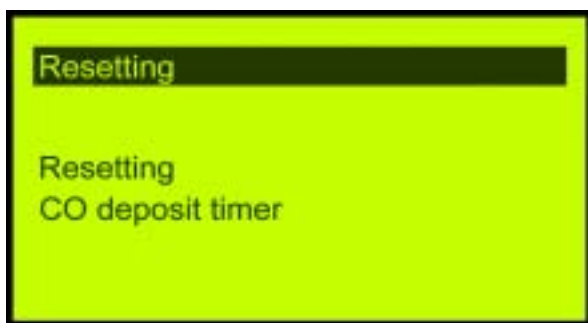

Fig 30

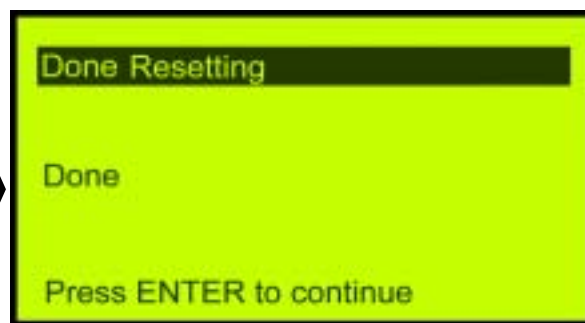

Fig 31

Press ENTER key to left this set up function menu.

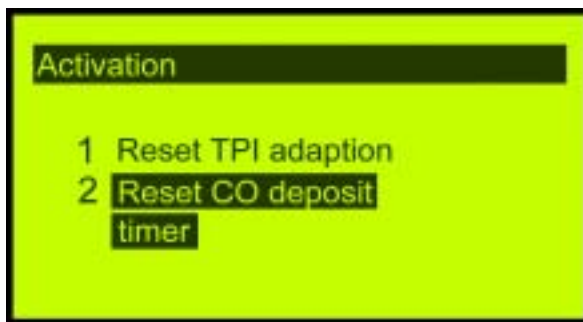

Fig 32

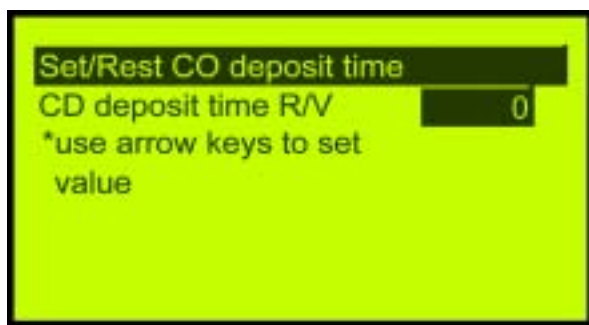

Fig 33

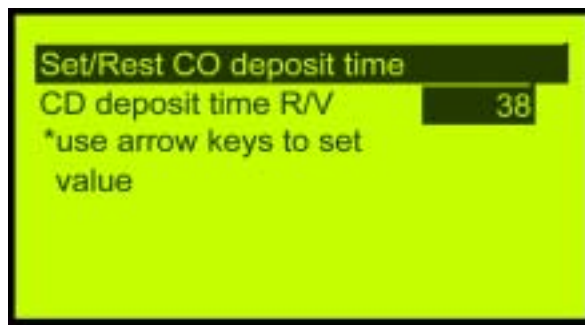

Fig 34

9. With the ▲▼ cursor to select “6. Waveform” analysis (as fig 35), press ENTER to enter into the waveform analysis menu. (as fig 36). 1. engine speed, 2. ignition timing (BTDC), 3. TPS, and 4. Atmosphere pressure sensor.

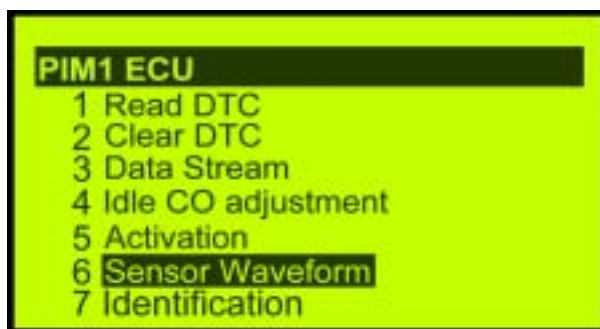

Fig 35

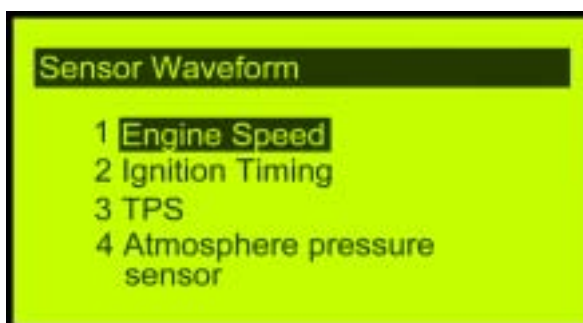

Fig 36

4. FUEL INJECTION SYSTEM

With the ▲▼ cursor to select “1. engine speed (as fig 37), press ENTER to enter into the “engine speed” menu to check current waveform. There are 3 instantly dynamic data values shown on the menu. (as fig 38, 39, 40). Select desired menu with ◀ ▶ cursor.

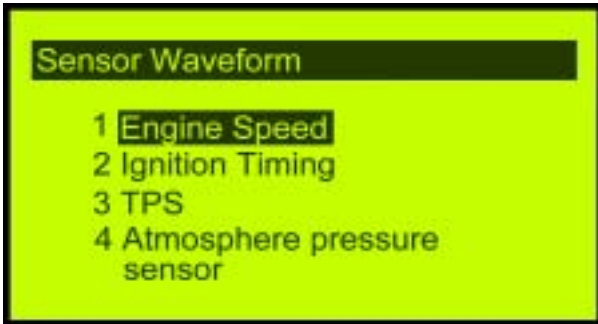

Fig 37



Fig 38

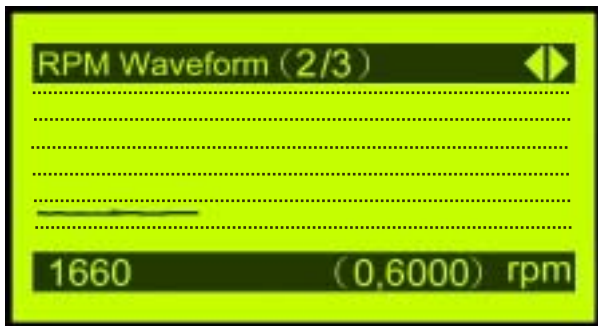

Fig 39

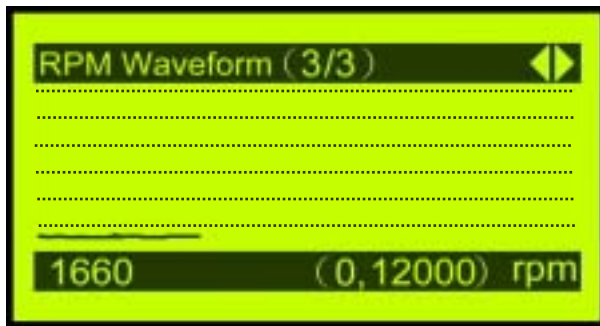

Fig 40

With the ▲▼ cursor to select “2. ignition timing (BTDC) (as fig 41), press ENTER to enter into the “ignition timing” menu to check current waveform. (as fig 42). Press EXIT key to left the “ignition timing” waveform menu.

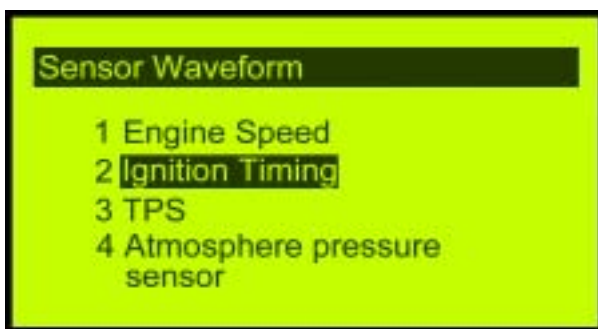

Fig 41



Fig 42

With the ▲▼ cursor to select “3. throttle position sensor (TPS) (as fig 43), press ENTER to enter into the “3. TPS” menu to check current waveform. (as fig 42). Press EXIT key to left the “TPS” waveform menu.



Fig 43

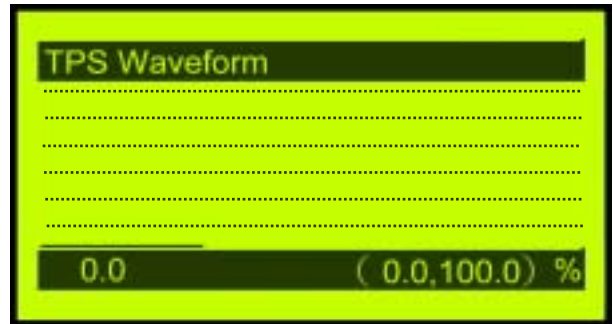

Fig 44

With the ▲▼ cursor to select “4. Atmosphere Pressure Sensor (as fig 45), press ENTER to enter into the “Atmosphere Pressure Sensor” menu to check current waveform. (as fig 46). Press EXIT key to left the “Atmosphere Pressure Sensor” waveform menu.

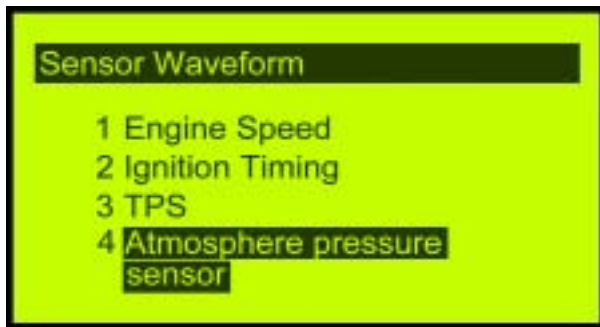

Fig 45



Fig 46

10. With the ▲▼ cursor to select “7. Identification” analysis (as fig 47), press ENTER to enter into the Identification analysis menu. (as fig 48, 49).

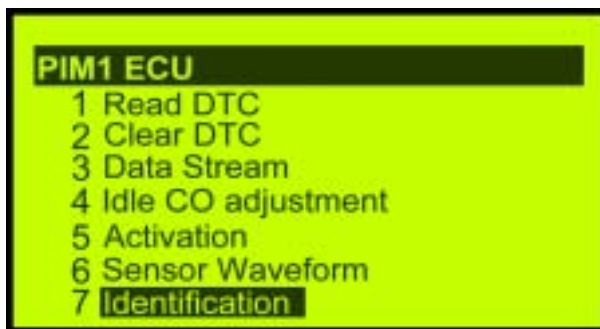

Fig 47

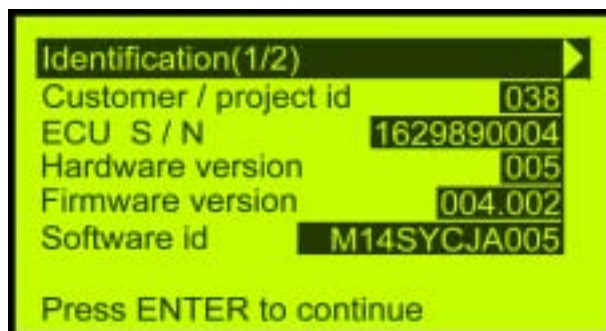

Fig 48

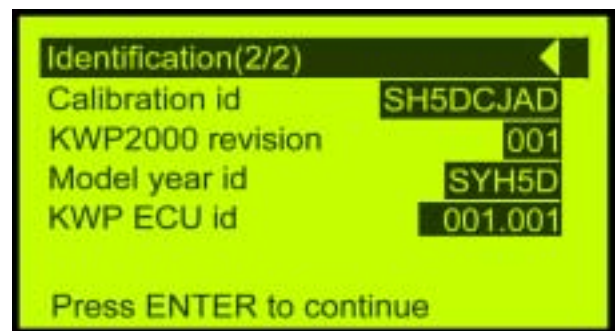

Fig 49

11. Here are all operation menus for the EFI Data Scan.

4. FUEL INJECTION SYSTEM

EFI Component Malfunction Check & Replacement Procedure (PI Engine)

PI (Port Injection) Intake manifold injection engine

Item	Parts No. Parts Name	Service schedule	Inspection Method	Adjustment & replacement procedure
1	390-002 Ignition coil	At least 20000km life-expecta ncy Check it every 3000km	<ol style="list-style-type: none"> 1. With the Data Scan to check if the ignition coil is malfunction. 2. Erase the DTC codes and replace with new one & confirm again. If the DTC codes disappear, then the ignition coil is abnormal. Replace it with new one. 3. If the DTC codes still exist, replace the ECU for confirm. If the DTC codes disappear, then the ECU is abnormal. Replace it with new one. 4. Before the ignition coil is verified in abnormal, check the coil resistance and connector wire for short-circuit. 	<ol style="list-style-type: none"> 1. If the ignition coil has to be changed, erase the DTC codes with the Data Scan. 2. Turn off ignition switch, and replace the coil with new one. 3. Turn on ignition switch and make sure the DTC codes disappear.
2	379-010 By-pass valve	At least 20000km life-expecta ncy Check it every 3000km	<ol style="list-style-type: none"> 1. Check if the by-pass valve DTC code shown with the Data Scan. 2. Erase the DTC codes and replace with new one & confirm again. If the DTC codes disappear, then the by-pass valve is abnormal. Replace it with new one. 3. If the DTC codes still exist, check if the wire connector and by-pass valve resistance are in normal. 4. If the DTC codes still exist, replace the ECU for confirm. If the DTC codes disappear, then the ECU is abnormal. Replace it with new one. 	<ol style="list-style-type: none"> 1. If the by-pass valve has to be changed, erase the DTC codes with the Data Scan. 2. Turn off the ignition switch, and then replace the valve with new one. 3. Turn on ignition switch and make sure the DTC codes disappear. 4. Check idle speed CO and adjust it if necessary.
3	358-016 fuel pump & regulator	At least 20000km life-expecta ncy Check it every 6000km	<ol style="list-style-type: none"> 1. Connect a pressure gauge between the regulator and fuel injector. 2. Make sure fuel pressure is within 2.5bar. The pressure is reached within 3 seconds after turn on ignition switch. 3. If the fuel pressure is out of specification, check if the fuel pipe is leaking. Is the fuel pump voltage over 12V? 4. Replace the regulator and confirm again. 	<ol style="list-style-type: none"> 1. The oil seal has to be replaced if it has to replace the regulator. 2. Oil seal has to be installed onto the outer cover, and then assemble it
4	366-005 Engine temperature sensor	At least 20000km life-expecta ncy Check it every 3000km	<ol style="list-style-type: none"> 1. Has the DTC code shown with the Data Scan. 2. Engine temperature has to be reached to room temperature after engine stopped for a while. 3. Erase the DTC codes and replace with new one & confirm again. If the DTC codes disappear, then the sensor is abnormal. Replace it with new one. 4. If the DTC codes still exist, check if wire connector and sensor's resistance are normal. 	<ol style="list-style-type: none"> 1. If the sensor has to be changed, erase the DTC codes with the Data Scan 2. Turn off ignition switch, and remove connector. 3. Remove the sensor with tools. 4. New component tighten torque is 0.74~0.88kg-m. 5. Connect the connector, and the Data Scan. Then, turn on ignition switch. 6. Make sure if the DTC codes are disappeared. 7. The value of stopped engine temperature should near to room temperature.



4. FUEL INJECTION SYSTEM

Item	Parts No. Parts Name	Service schedule	Inspection Method	Adjustment & replacement procedure
5	366-008 Intake temperature /pressure sensor	At least 20000km life-expectancy Check every 3000km	<ol style="list-style-type: none"> 1. Connect the Data Scan as inspection. The engine intake temperature and pressure should close to environmental temperature & atmosphere pressure. (conduct this task after stopped the engine for a while) 2. If the DTC codes of intake temperature or pressure shown on the Data Scan, replace the pressure sensor firstly with new one. Make sure if the DTC codes are disappear. If not, check the connector wire for short-circuit. Replace the connector if necessary. 3. If the DTC codes still exist, replace the ECU. 4. If the DTC codes are disappear, install the original pressure sensor and check it again. If the DTC codes are disappear, then, replace the ECU with new one. 	Replacement procedure for T-MAP (intake temperature/pressure sensor) <ol style="list-style-type: none"> 1. Turn off the ignition switch. 2. Disconnect the connector of intake temperature/pressure sensor. Replace the sensor with new one. 3. Connect the connector with Data Scan. 4. Turn on the ignition switch, and check if the intake temperature/pressure close to environmental temperature and atmosphere pressure with the Data Scan. 5. Erase the DTC codes, and make sure the problem is solved.
6	308-008 Throttle body	At least 20000km life-expectancy Check every 3000km	<ol style="list-style-type: none"> 1. Please refer to idle speed adjustment section for the idle speed CO adjustment. 2. Connect the Data Scan and check if the throttle position DTC code appears. 3. If the code appears, replace the throttle body to make sure the code can be erased. 4. If the code disappears, replace the throttle body. 5. If the code still exists, replace the ECU with new one. Then, if the code can be erased, the ECU has to be replaced. 	The throttle body replacement procedure: <ol style="list-style-type: none"> 1. Install a new throttle body 2. Make sure there is no leaking. 3. Connect the Data Scan and record carbon accumulated time. 4. Re-set the time with the Data Scan. 5. Re-set the throttle position data with the Data Scan. 6. Throttle valve WOT set up. Turn off ignition switch, and WOT the throttle valve and hold it. Turn on the ignition switch and hold for 2 seconds. Release the throttle valve. 7. Please refer to the idle speed adjustment section for the idle speed CO if necessary.
7	337-004 Fuel injector	At least 20000km life-expectancy Check every 3000km	<ol style="list-style-type: none"> 1. Check if the fuel injector DTC code appears. 2. If the code appears, replace a new fuel injector for confirmation. If the code can be erased, then, replace the fuel injector. 3. If the code still can not be clear, check if connector wire is in short-circuit. 4. If the code still exists, replace the ECU with new one. Then, if the code can be erased, the ECU has to be replaced. 	Confirmation or replacement procedure for the fuel injector: <ol style="list-style-type: none"> 1. Erase the DTC code with the Data Scan. 2. Turn off ignition switch and disconnect the fuel injector connector. 3. Connect the connector to a new fuel injector. 4. Connect the Data Scan, and turn on the ignition switch. 5. Make sure the DTC code had been clear. 6. Please refer to idle speed adjustment section for idle speed CO value confirmation. (Firstly, make sure if the fuel injector DTC code had been clear, and then install a new fuel injector.)

4. FUEL INJECTION SYSTEM

Item	Parts No. Parts Name	Service schedule	Inspection Method	Adjustment & replacement procedure
8	325-002 ECU	At least 20000km life-expectancy Check every 3000km	<ol style="list-style-type: none"> 1. Connect the Data Scan. 2. Record the ECU service time. 	<p>ECU replacement procedure:</p> <ol style="list-style-type: none"> 1. Connect the Data Scan onto the original ECU. 2. Record the ECU service time. 3. Turn off the ignition switch. 4. Replace the ECU with new one. 5. Re-set the ECU service time. 6. Clean the carbon deposition around the throttle body. 7. Please refer to idle speed adjustment section for idle speed CO value confirmation.
9	Idle speed CO Adjustment	Check for new motorcycle and every 3000km.	<ol style="list-style-type: none"> 1. Warm up the motorcycle by running it in 50km/hr for 5 minutes. 2. Connect the Data Scan. 3. Record the idle speed CO value, rpm, and carbon deposition accumulated time. 	<ol style="list-style-type: none"> 1. Warm up the motorcycle by running it in 50km/hr for 5 minutes. 2. Connect the Data Scan. 3. Record the idle speed CO value, rpm, and carbon deposition accumulated time. 4. With the Data Scan to adjust the idle speed CO value to be 0.5%~2.0%. 5. Record the idle speed CO value, rpm and CO variant value. 6. (The engine temperature has to be in 115 ~140 , and intake temperature to be in 25 ~40 as adjusting.)

Operational Precautions 5-1	Engine Suspension Frame 5-8
Engine Removal 5-2	Installation Of Engine 5-9
Removal Of Engine Suspension Bushing 5-7	

Operational Precautions

General Information

- Engine must be supported by a bracket or adjustable tool in height.
- The following parts can be serviced with the engine installed on the frame.
 1. Throttle valve
 2. Driving disk, driving belt, clutch, and transporting disk
 3. Final reduction gear mechanism

Specification

Item		Specification
Engine Oil Capacity	Replacement	800 c.c.
	Disassemble	1000 c.c.
Gear Oil Capacity	Replacement	100 c.c.
	Disassemble	110 c.c.

Torque Values

Engine suspension bolt (Frame side)	4.5~5.5 kgf-m
Engine suspension nut (engine side)	4.5~5.5 kgf-m
Bolt of rear shock absorber upper connection	3.5~4.5 kgf-m
Bolt of rear shock absorber lower connection	2.4~3.0 kgf-m
Bolt of rear brake clipper	2.9~3.5 kgf-m
Nut of rear wheel axle	11.0~13.0 kgf-m
Nut of exhaust connection	0.5~1.0 kgf-m
Bolt of exhaust fixed	3.0~3.6 kgf-m
Bolt of rear bracket	3.0~3.6 kgf-m

5. REMOVAL OF ENGINE

Engine Removal

Remove the battery cap (Nut x3).
 Remove the battery negative (-) cable.
 Remove the battery positive (+) cable.



Open seat cushion.
 Remove the trunk assembly. (bolt x 4, screw x 1)
 Remove rear bracket and fuel tank cap.
 (hex-socket bolt x 4)
 Remove both left & right body covers and central upper cover set. (screw x 4)
 Remove both left & right side covers. (screw x4)
 Remove both left & right pedals of rear seat.
 (screw x 8)
 Remove central cover. (screw x2)



Remove the connector of rear lamp power wire.
 Remove the generator power wire and speed sensor connector.



Remove the starter motor cable on the relay.

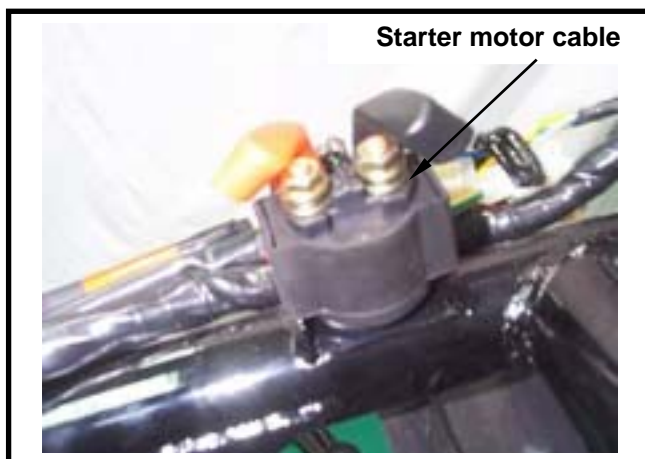



5. REMOVAL OF ENGINE

Remove the spark plug.
Remove the engine temperature sensor connector.

⚠ Caution

Open the latch located under the temperature sensor before disconnect it so that the connector can be pull out and not be damaged.

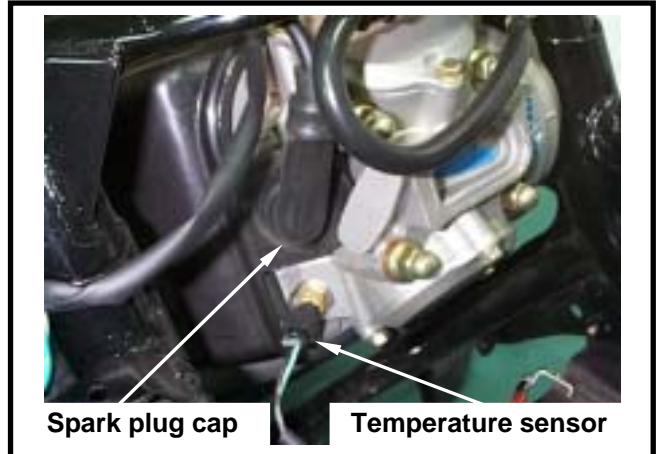

Remove the by-pass pipe and disconnect circuit connector.

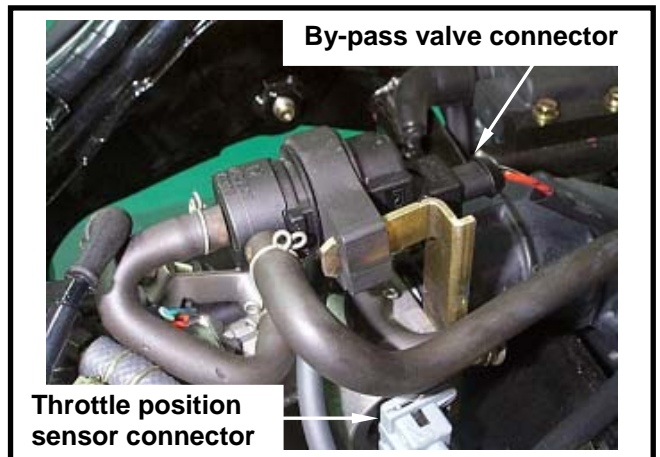

Remove the throttle body lines and throttle body cables.
Disconnect the connector of throttle position sensor.
Loosen the clamp of the air cleaner duct, and then remove the duct.

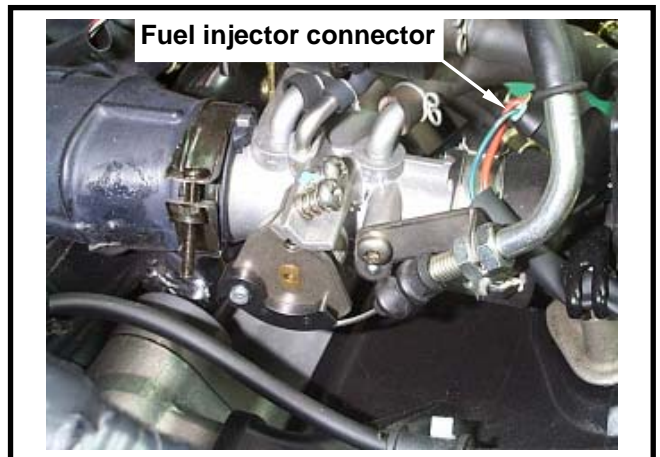

Remove the fuel injector line and circuit connectors.



5. REMOVAL OF ENGINE

Remove the throttle body and the fuel injector.
(nut x 2)

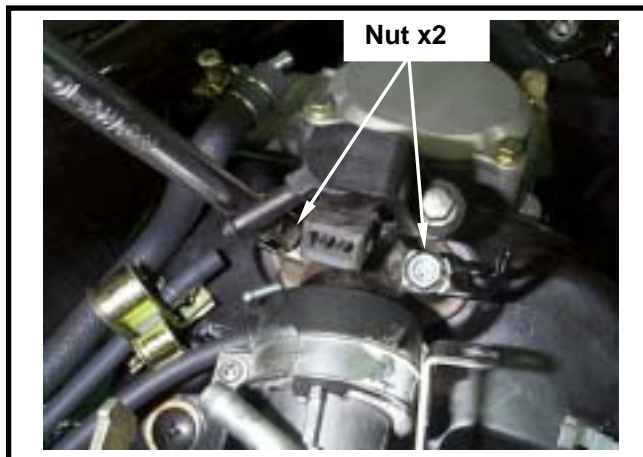

Loose the strap screw of the air duct on the engine left side, and then remove the air duct.
Remove the air cleaner bolts. (bolt x 2)

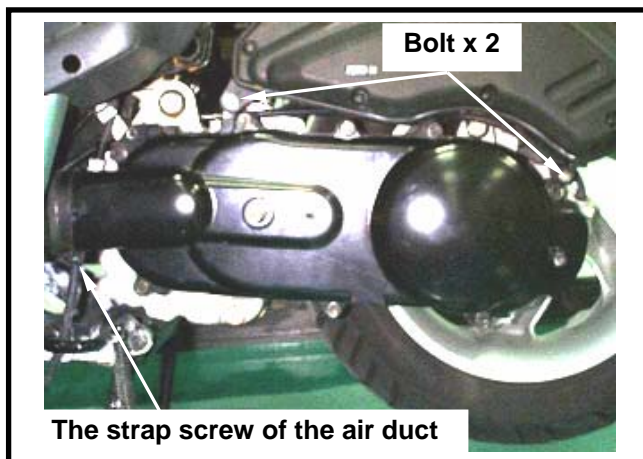

Remove the front-end nuts of exhaust pipe.
(Nut x2)

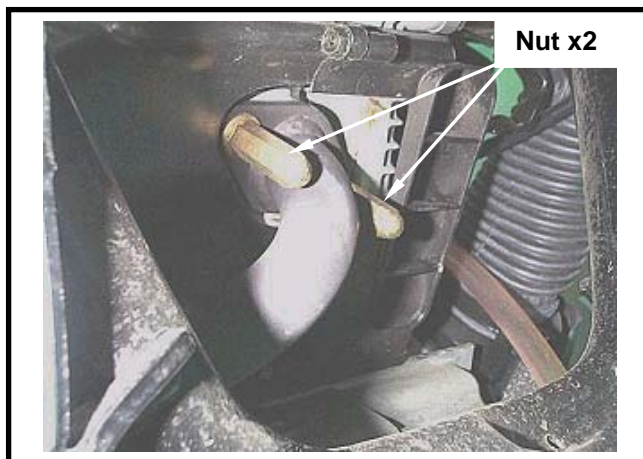

Remove the rear-end bolts of exhaust pipe.
(Bolt x3)
Remove the exhaust pipe.

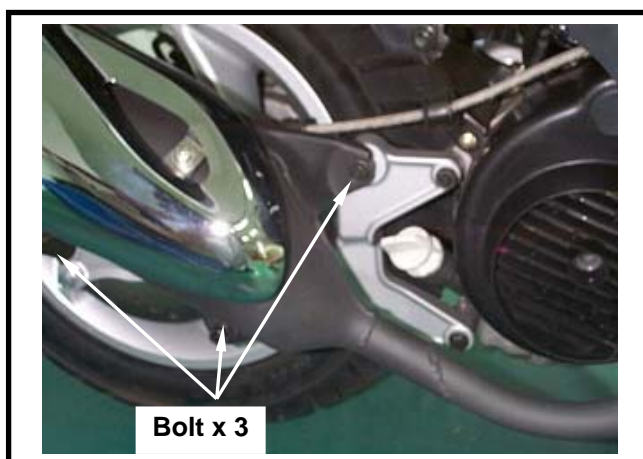

Remove the rear brake pipe seat. (bolt x 2)
Remove the rear brake assembly. (bolt x 2)

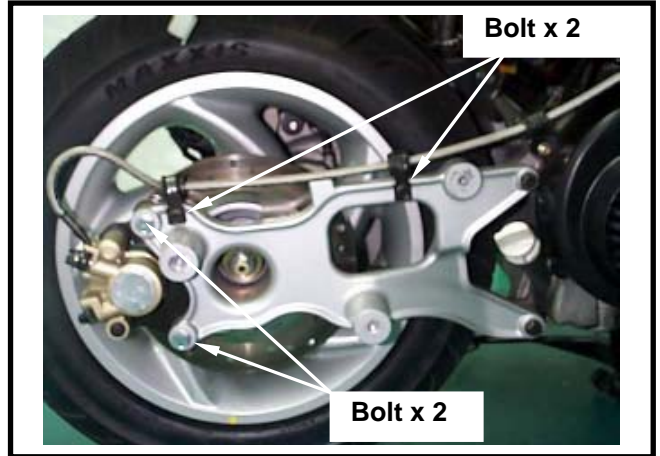

Remove the front-end nut of rear bracket. (bolt x 2)
Remove the rear wheel axle nut. (nut x 1)

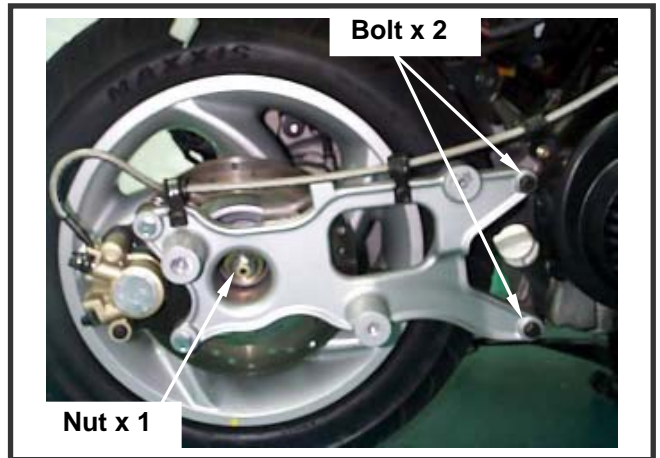

Remove the rear bracket.



5. REMOVAL OF ENGINE

Engine suspension removal

Remove the rear shock absorber lower bolt.
(bolt x 1)



Remove the side hole cap of cooling fan.

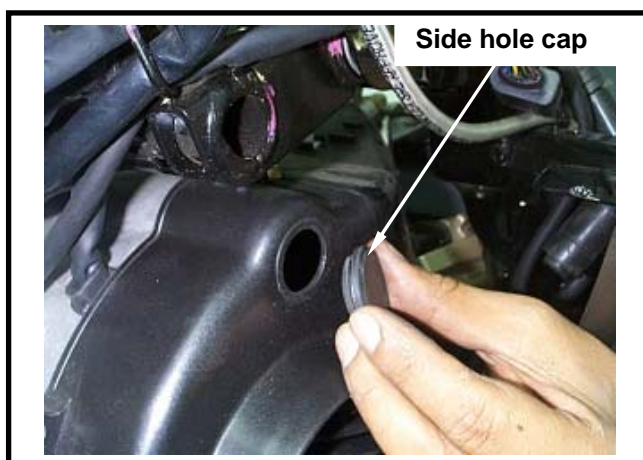

Remove the engine suspension nuts, and then remove the bolt from the side hole.

⚠ Caution

With a bracket to support the engine to prevent from it damage by falling down as removing the engine.

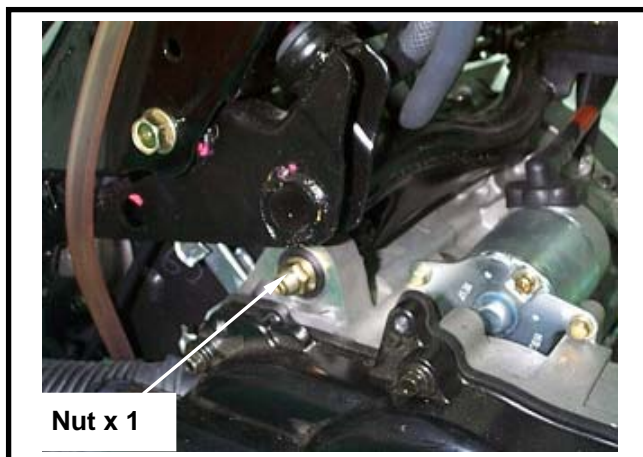

Check if the engine suspension, rear shock absorber bushing, and cushion rubber for damage. Replace them with new ones if so.



Removal Of Engine Suspension Bushing

If engine suspension frame and the cushion rubber of rear shock absorber bushing damaged. Then, with the bushing remover / pressor, \varnothing 28mm & \varnothing 20mm, to press the bushing out, and replace it with new one.

Engine suspension bushing: \varnothing 28mm
Rear shock absorber bushing: \varnothing 20mm



Pressing out

Place the detent section of the bushing remover toward the bushing, and drive both the pressing ring and bolt in to press the bushing out.



Pressing In

Place the flat section of the remover toward the bushing, and then drive the bushing, pressing ring, and bolt in to install the bushing.

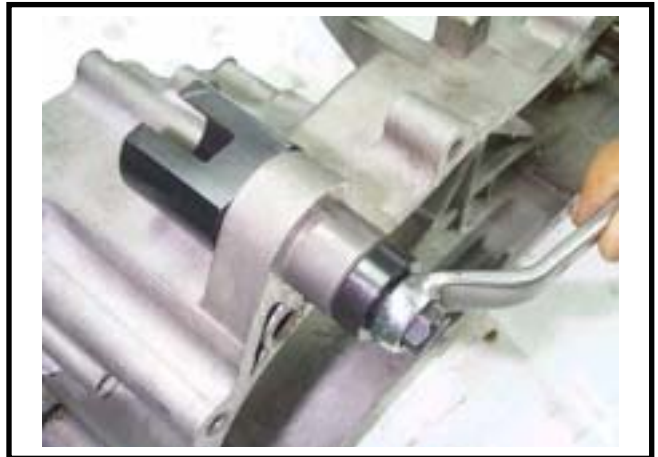

5. REMOVAL OF ENGINE

Engine Suspension Frame

Removal

Remove the right side bolt of engine suspension frame.

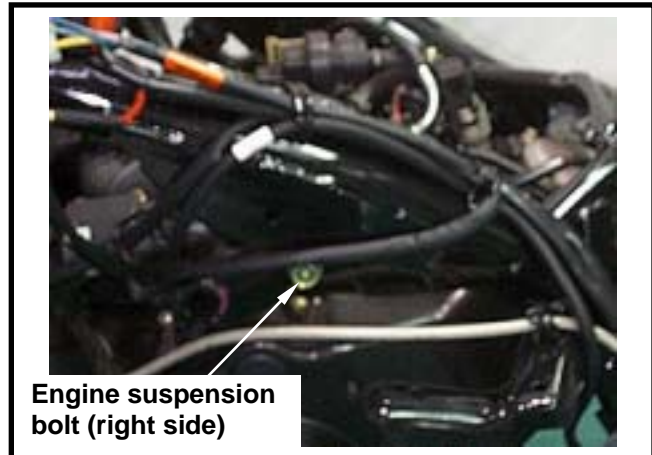

Remove the left side bolt of engine suspension frame.



Check if the engine suspension frame bushing and cushion rubber for damage. If so, replace with new ones.

Installation

Tighten the bolts and nuts of engine suspension frame.

Engine suspension frame nut:
Torque Value: 4.5~5.5 kgf-m

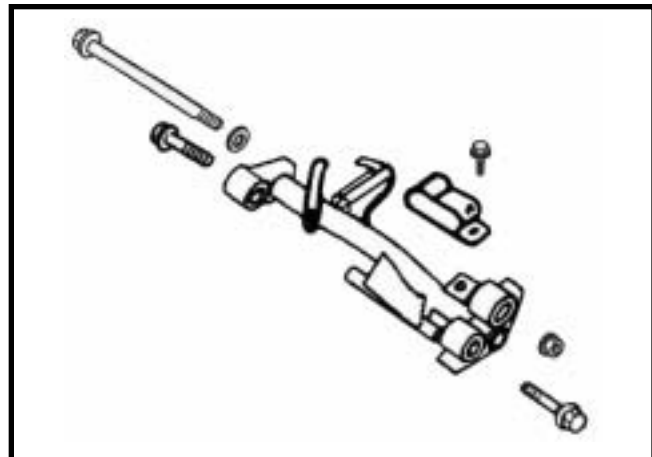

Installation Of Engine

Check if the bushings of engine suspension frame and shock absorber for damaged. If so, replace with new ones.

Install the engine according to the reversing order of removal.

⚠ Caution

- Note both feet and hands safety for squeezing as engine installation.
- Do not bent or squeeze each wires or hose.
- Route all cables and wires in accordance with the routine layout.

Engine suspension nut:

Torque Value: 4.5~5.5 kgf-m

Rear shock absorber bolt:

Torque Value: Top: 3.5~4.5 kgf-m

Down: 2.4~3.0 kgf-m

Rear wheel axle nut:

Torque Value: 11.0~13.0 kgf-m

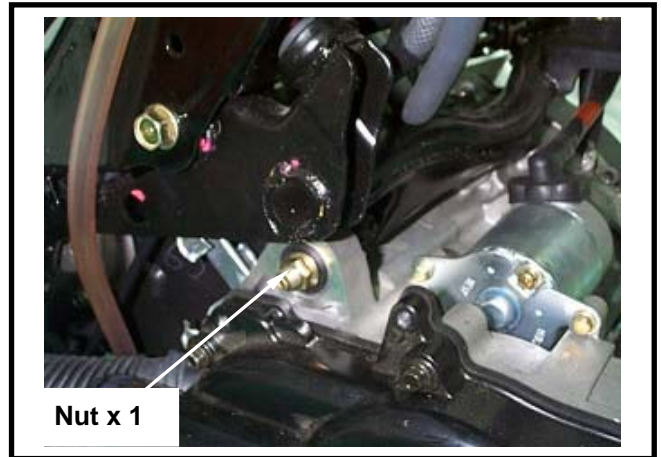

5. REMOVAL OF ENGINE

NOTES:

Mechanism Illustration.....6-1	Valve Stem Replacement..... 6-9
Precautions In Operation.....6-2	Valve Seat Inspection And Service 6-10
Troubleshooting6-3	Cylinder Head Reassembly 6-12
Cylinder Head Removal6-4	Cylinder Head Installation 6-14
Cylinder Head Disassembly6-6	Valve Clearance Adjustment..... 6-16
Cylinder Head Inspection6-7	

Mechanism Illustration

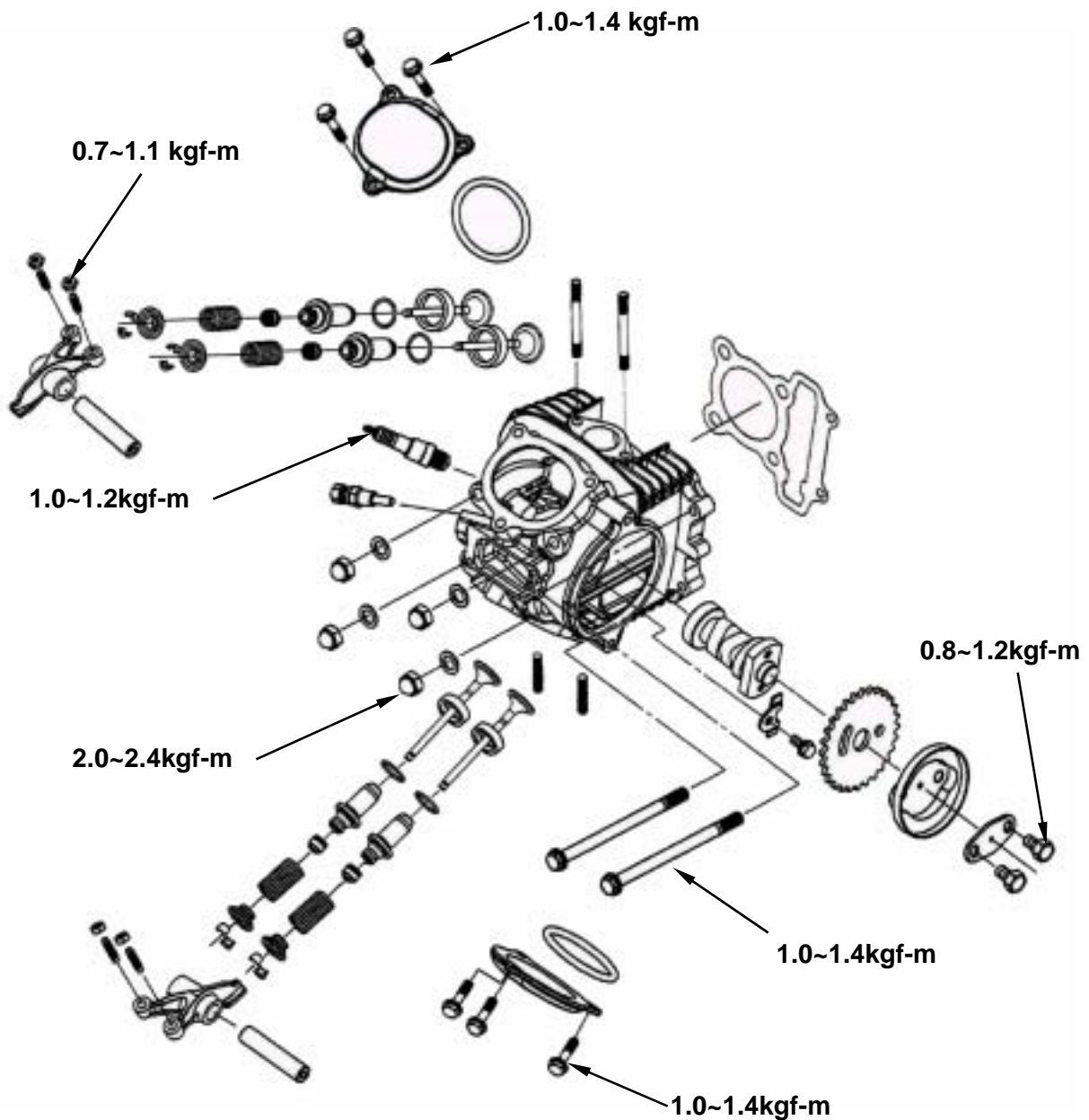

6. Cylinder Head/Valve

Precautions In Operation

General Information

- This chapter is contained maintenance and service for cylinder head, valve, and camshaft as well as rocker arm.
- Cylinder head service cannot be carried out when engine is in frame.

Specification

Unit: mm

Item		Standard	Limit	
Compression pressure		12 ± 2 kg/cm ²	-	
Camshaft	Height of cam lobe	Intake	25.688	
		Exhaust	25.519	
Rocker arm	ID of valve rocker arm	12.000~12.015	12.100	
	OD of valve rocker arm shaft	11.966~11.984	11.910	
Valve	OD of valve stem	Intake	4.975~4.990	
		Exhaust	4.950~4.975	
	Guide seat		5.000~5.012	5.030
	Clearance between valve stem and guide	Intake	0.010~0.037	0.080
		Exhaust	0.025~0.062	0.100
	Free length of valve spring		35.000	31.500
	Valve seat width		1.000	1.600
Connection Flatness of cylinder head		-	0.050	

Torque Value

Cylinder head bolt	1.0~1.4kgf-m
Cylinder head bolt (LH)	1.0~1.4kgf-m
Cylinder head Nut	1.8~2.2kgf-m (apply with oil on bolt thread & seat)
Sealing bolt of timing chain auto-tensioner	0.8~1.2kgf-m
Bolt of timing chain auto-tensioner	1.0~1.4kgf-m
Timing gear cover bolts	0.7~1.1kgf-m (apply with oil on bolt thread & seat)
Spark plug	1.0~1.4kgf-m

TOOLS

Special service tools

- Valve reamer: 5.0mm
- Valve guide driver: 5.0mm
- Valve spring compressor

Troubleshooting

Engine performance will be effected by troubles on engine top-end. The troubles usually can be determinated or by performing cylinder compression test and judging the abnormal noise generated.

Rough Idle

- Low compression pressure

Low compression pressure

1. Valve

- Improper valve adjustment
- Burnt or bended valve
- Improper valve timing
- Valve spring damaged
- Valve carbon
- Poor sealing on valve seat
- Improper spark plug installation

2. Cylinder head

- Cylinder head gasket leaking or damage
- Tilt or crack cylinder surface

3. Piston

- Piston ring worn out

High compression pressure

- Too much carbon deposit on combustion chamber or piston head

Noise

- Improper valve clearance adjustment
- Burnt valve or damaged valve spring
- Camshaft wear out or damage
- Cam chain wear out or looseness
- Auto-tensioner wear out or damage of cam chain
- Camshaft sprocket wear out
- Rocker arm or rocker arm shaft wear out

White smoke

- Valve guide or valve stem wear out
- Valve stem seal wear out

6. Cylinder Head/Valve

Cylinder Head Removal

Remove:

Remove the cooling fan cover. (screw x 2, bolt x 2)

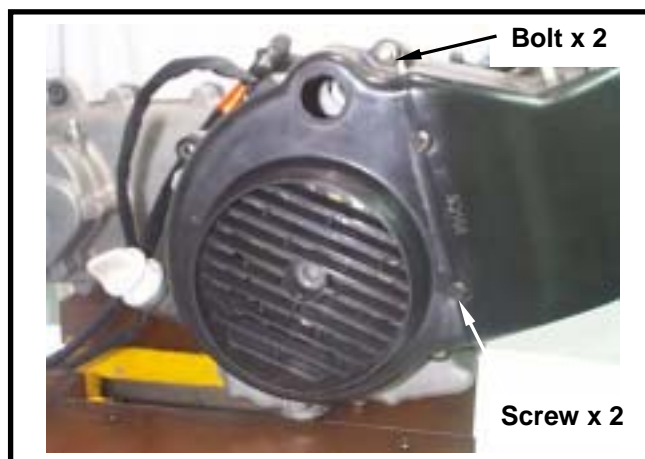

Remove the right cover of engine. (screw x 4)

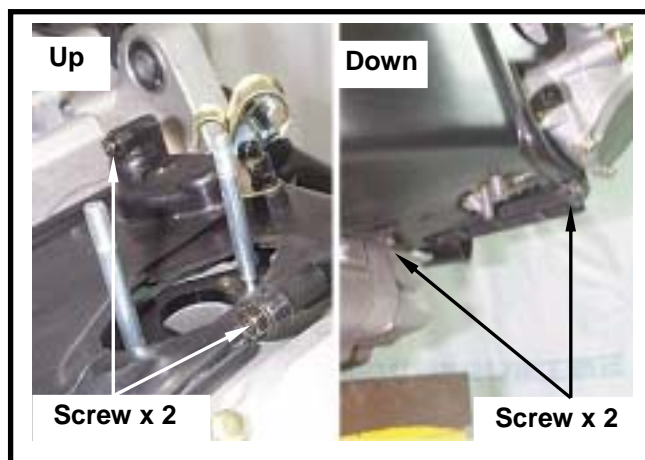

Remove the left cover of engine. (screw x 4)

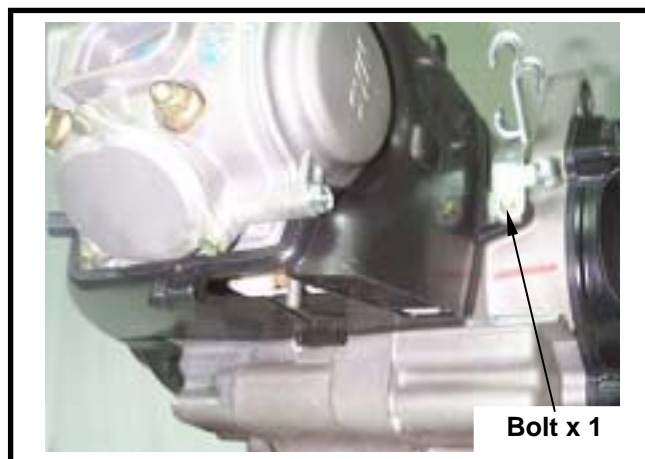

Remove the left cap bolt of cylinder head (bolt x2), and then remove the left cap of cylinder head.

Remove the spark plug.

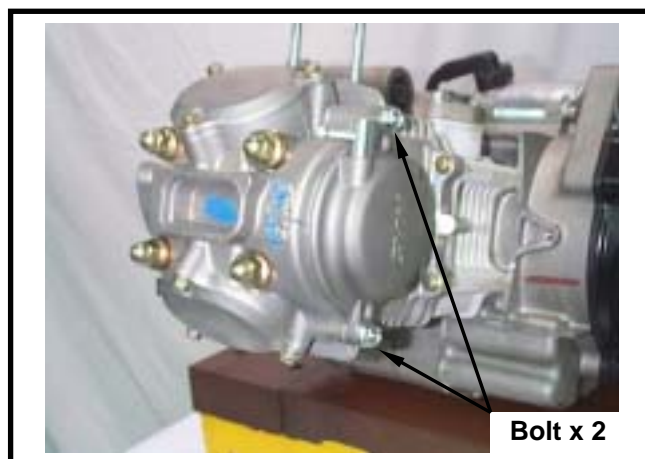

Turn the flywheel in counter clockwise motion with T type wrench until the “T” mark on flywheel aligned with the mark on the crankcase so that the hole on the camshaft sprocket is forward up and piston is at TDC position.

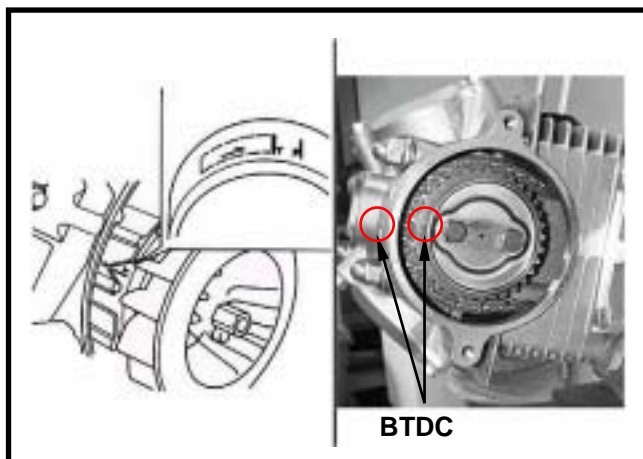

Loosen the screw cap of camshaft chain tensioner and remove O-ring.
With a flat screwdriver to tighten the screw of camshaft chain tensioner in a clockwise motion for release tensioner.



Remove the cam sprocket. (bolt x2)

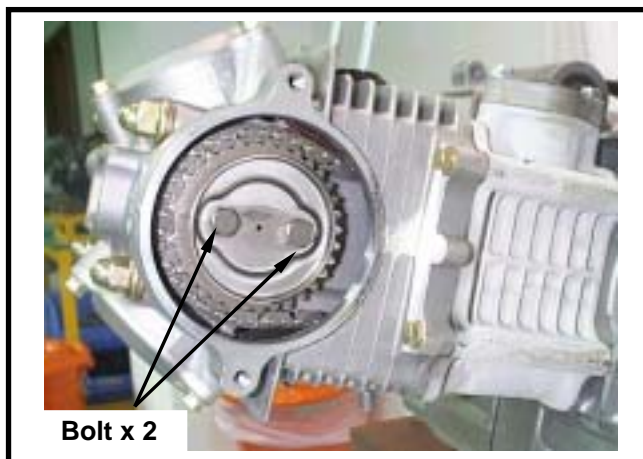

Remove the left bolt (bolt x2) of cylinder head firstly, and then remove the 4 nuts & washers from the cylinder head top-end.
Pry out the chain and take out the sprocket.
Then, remove the cylinder head.

⚠ Caution

- Loosen the nuts diagonally by 2-3 sequences.
- Do not let the chain fall into the crankcase after removed the sprocket.

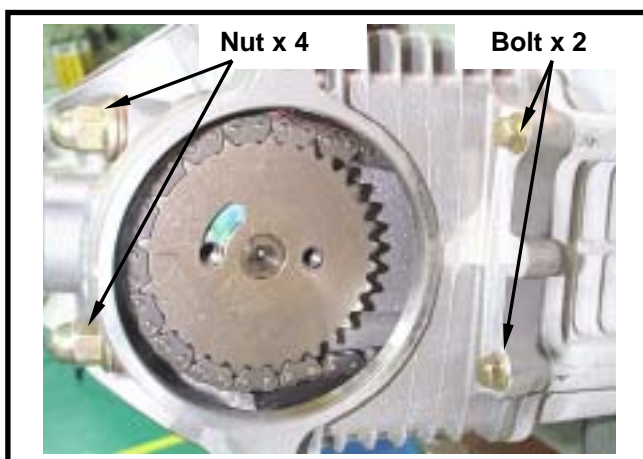

6. Cylinder Head/Valve

Cylinder Head Disassembly

Remove the adjustment hole cap for the EX & IN valve clearance. (bolt x 6)



Firstly, remove the camshaft stopper, and then drive a 6mm bolt into camshaft. Finally, remove the camshaft and rocker arm.

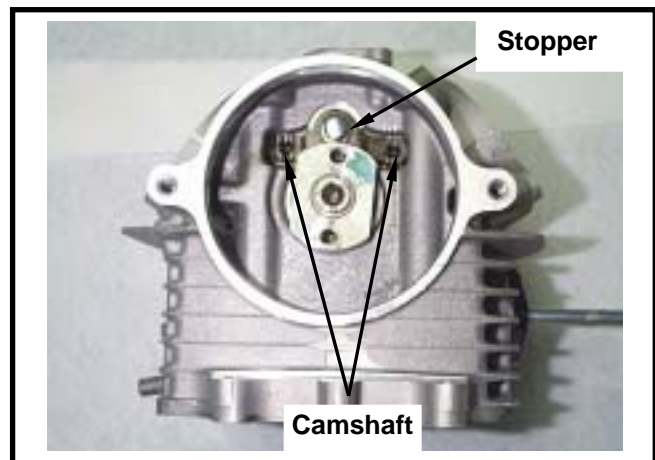

Use a valve compressor to press the valve spring. After removed valve split locks, release the compressor and then take out spring retainer, valve spring and valves.

⚠ Caution

In order to avoid losing spring elasticity, do not press the spring too much. Thus, press length is based on the valve split locks in which can be removed.

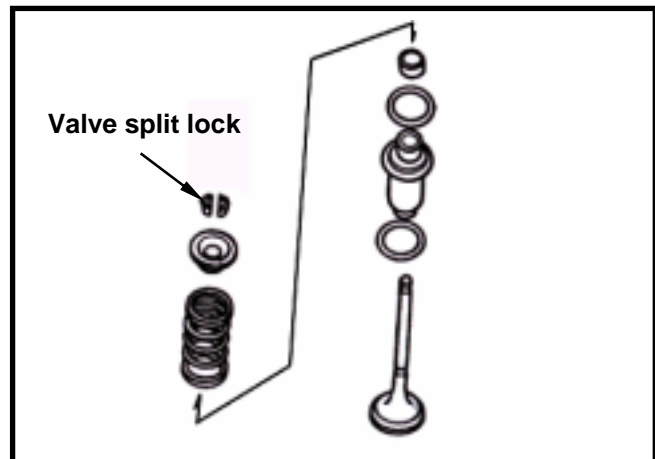

Special Service Tool: Valve spring compressor

Or with the valve spring remover/installer to compress the valve spring directly. Then, remove the valve and valve spring.

⚠ Caution

In order to avoid damaging the valve stem and the cylinder head, in the combustion chamber place a rag between the valve spring remover/installer as compressing the valve spring directly.



Special Service Tool: Valve spring remover/installer.

Remove valve, valve stem and valve spring.



Cylinder Head Inspection

Camshaft

Inspect cam lobe height for damaged.

Service Limit:

IN: Replacement when less than 25.29mm

EX: Replacement when less than 25.12mm

Inspect the camshaft bearing for looseness or wear out. If any, replace whole set of camshaft and bearing.

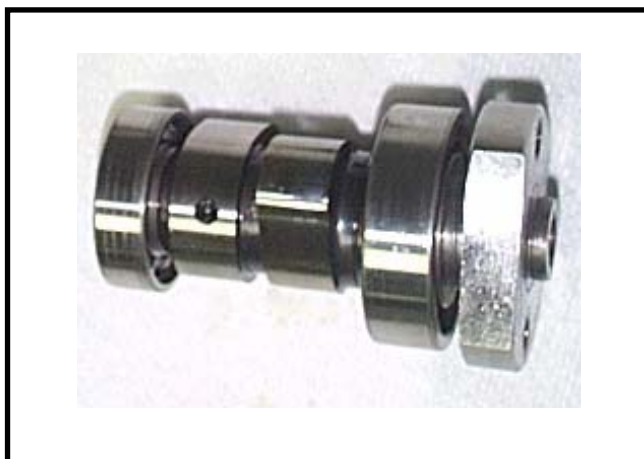

Rocker Arm

Measure the cam rocker arm I.D.

Service Limit: Replace when it is less than 12.10 mm.

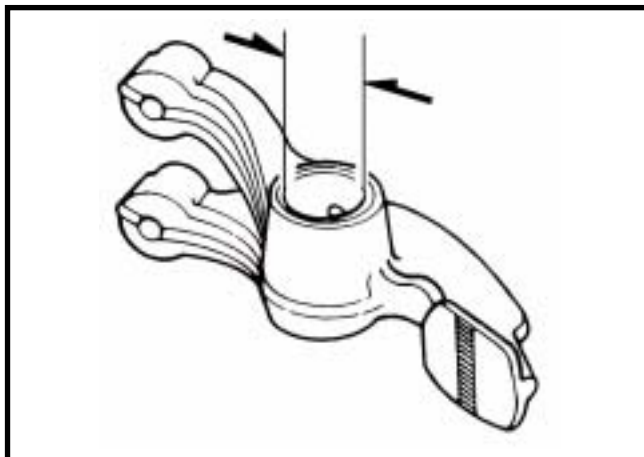

Rocker Arm Shaft

Measure the active O.D. of the cam rocker arm shaft and cam rocker arm.

Service Limit: Replace when it is less than 11.91 mm.

Calculate the clearance between the rocker arm shaft and the rocker arm.

Service Limit: Replace when it is less than 0.10 mm.

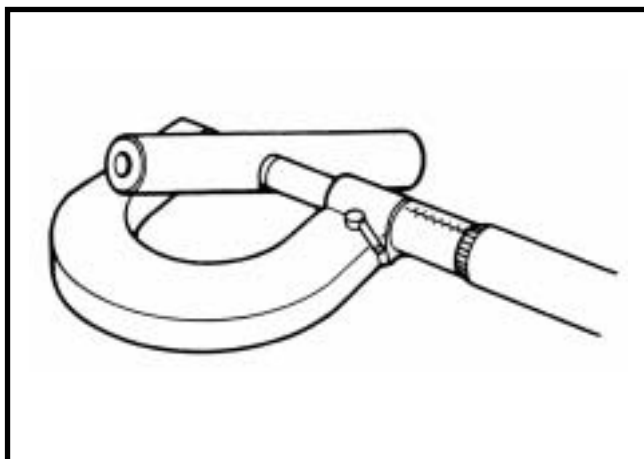

6. Cylinder Head/Valve

Remove cylinder head gasket and 2 lock pins.
Remove chain plate.
Clean up residues from the matching surfaces of cylinder and cylinder head.

Caution

- Do not damage the matching surfaces of cylinder and cylinder head.
- Avoid residues of gasket or foreign materials falling into crankcase as cleaning.

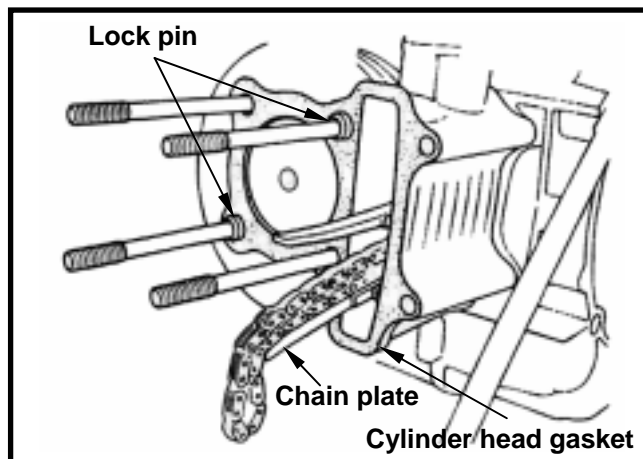

Remove valve stem guide seal.
Clean carbon deposits in combustion chamber.
Clean residues and foreign materials on cylinder head matching surface.

Caution

Do not damage the matching surface of cylinder head.

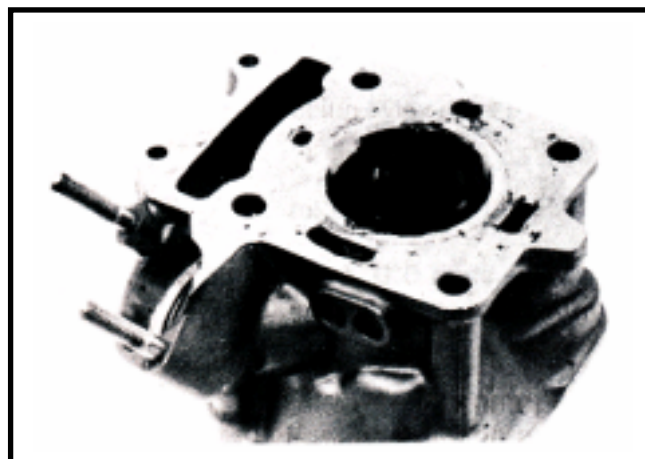

Cylinder Head

Check if spark plug and valve holes are crack.
Measure cylinder head wrapage with a straightedge and flat feeler gauge.

Service limit: 0.5 mm

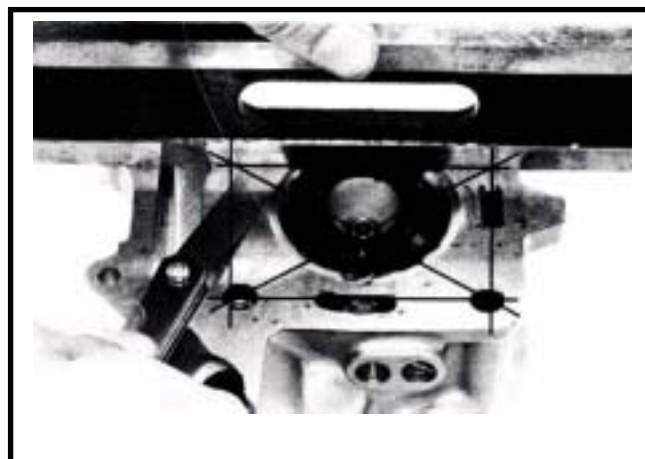

Valve Spring Free Length

Measure the free length of intake and exhaust valve springs.

Service limit: 31.5 mm

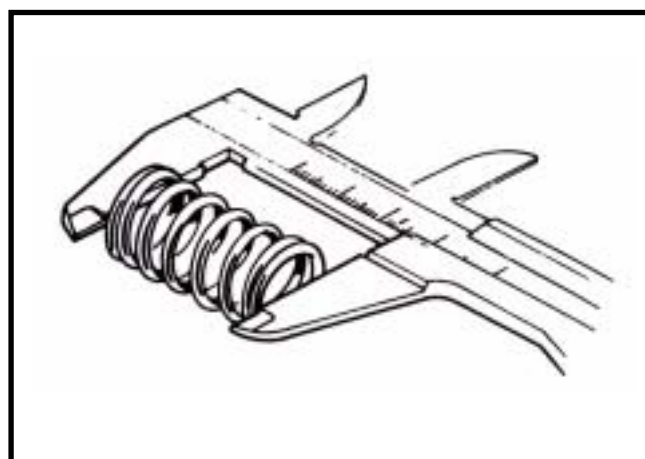

Valve Stem

Check if valve stems are bend, crack or burn.
Check the operation condition of valve stem in valve guide, and measure & record the valve stem outer diameter.

Service Limit: IN 4.90 mm
EX 4.90 mm

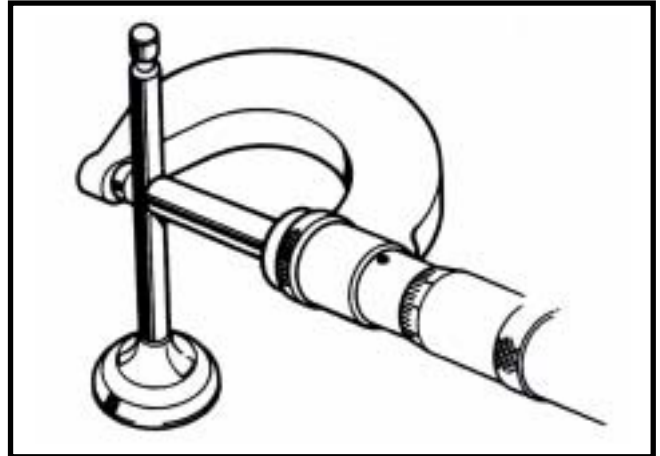

Valve Guide

⚠ Caution

Before measuring the valve guide, clean carbon deposits with reamer.

Special Service Tool: 5.0mm valve guide reamer
Measure and record each valve guide inner diameters.

Service limit: 5.03 mm

The difference that the inner diameter of valve guide deducts the outer diameter of valve stem is the clearance between the valve stem and valve guide.

Service Limit: IN 0.08 mm
EX 0.10 mm

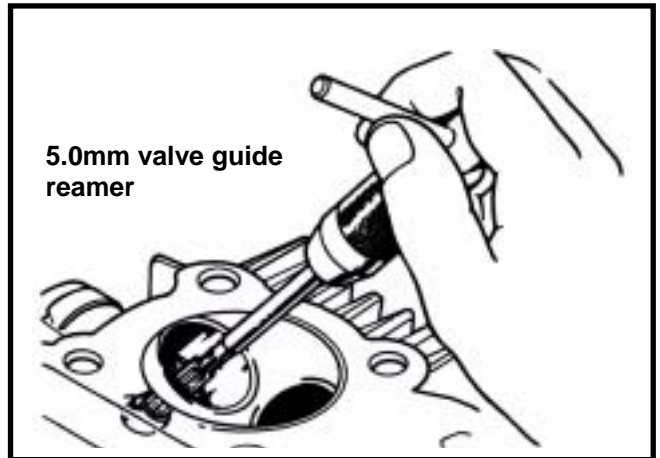

⚠ Caution

If clearance between valve stem and valve guide exceeded service limit, check whether the new clearance that only replaces new valve guide is within service limit or not. If so, replace valve guide.

Correct it with reamer after replacement.
If clearance still exceeds service limit after replaced valve guide, replace valve stem too.

⚠ Caution

It has to correct valve seat when replacing valve guide.

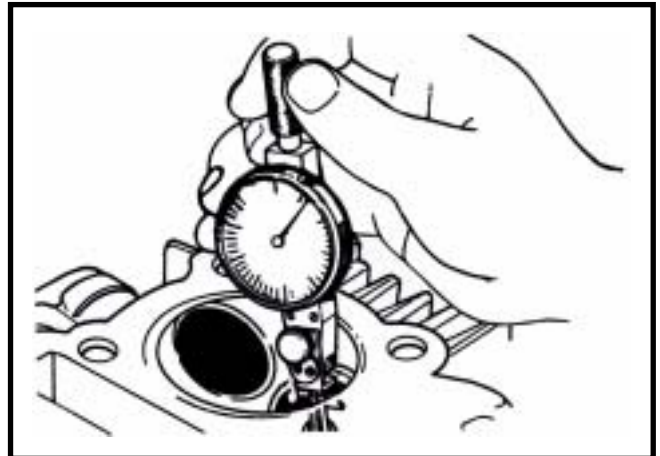

Valve Stem Replacement

Heat up cylinder head to 100~150 with heated plate or toaster.

⚠ Caution

- Do not let torch heat cylinder head directly. Otherwise, the cylinder head may be deformed as heating it.
- Wear on a pair of glove to protect your hands when operating.

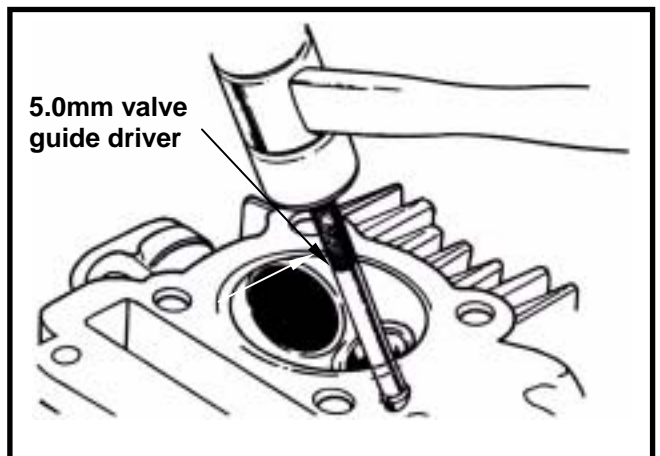

6. Cylinder Head/Valve

Hold the cylinder head, and then press out old valve guide from combustion chamber side.

Tool: Valve guide driver: 5 mm

⚠ Caution

- Check if new valve guide is deformation after pressed it in.
- When pressing in the new valve guide, cylinder head still have to be kept in 100~150 .

Adjust the valve guide driver and let valve guide height is in 13mm.

Press in new valve guide from rocker arm side.

Tool: Valve guide driver: 5 mm

Wait for the cylinder head cooling down to room temperature, and then correct the new valve guide with reamer.

⚠ Caution

- Using cutting oil when correcting valve guide with a reamer.
- Turn the reamer in same direction when it be inserted or rotated.

Correct valve seat, and clean up all metal residues from cylinder head.

Tool: Valve guide reamer 5 mm

Valve Seat Inspection And Service

Clean up all carbon deposits onto intake and exhaust valves.

Apply with emery slightly onto valve contact face.

Grind valve seat with a rubber hose or other manual grinding tool.

⚠ Caution

- Do not let emery enter into between valve stem and valve guide.
- Clean up the emery after corrected, and apply with red paint onto contact faces of valve and valve seat.

Remove the valve and check its contact face.

⚠ Caution

- Replace the valve with new one if valve seal is roughness, wear out, or incomplete contacted with valve seat.
- If the valve and the valve seat still can not be matched sealing after grinded, replace it with new one.

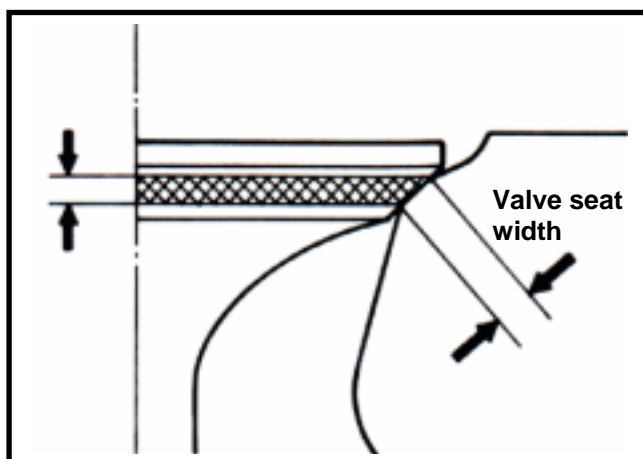
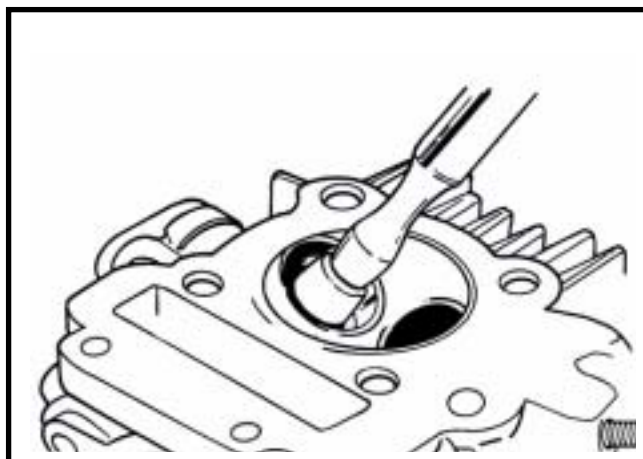
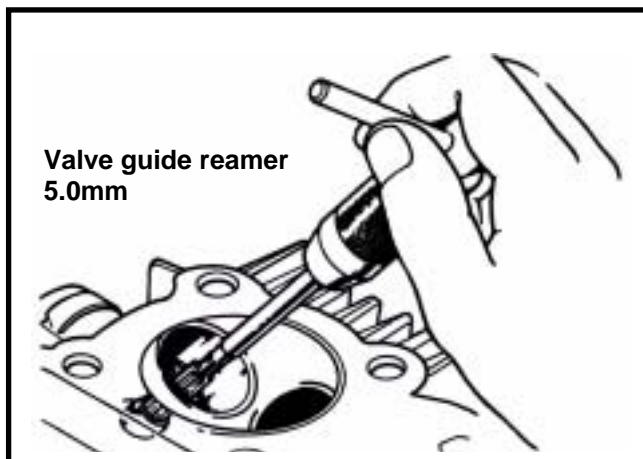
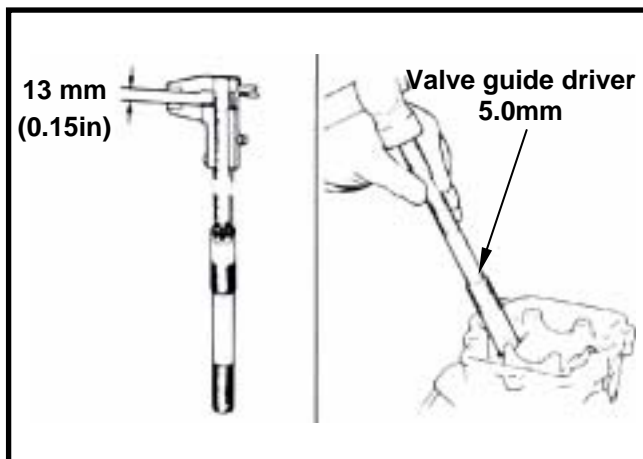

Valve Seat Inspection

If the valve seat is too wide, narrow or rough, correct it.

Valve seat width

Service limit: 1.6 mm

Check the contact condition of valve seat.

Valve Seat Grinding

The worn valve seat has to be grinded with valve seat chamfer cutter.

Use 45° valve seat chamfer cutter to cut any rough or uneven surface from valve seat.

⚠ Caution

After valve guide had been replaced, it has to be grinded with 45° valve seat chamfer cutter to correct its seat face.

Use 32° cutter to cut a quarter upper part out.

Use 60° cutter to cut a quarter lower part out.
Remove the cutter and check new valve seat.

Use 45° cutter to grind the valve seat to specified width.

⚠ Caution

Make sure that all roughness and uneven faces had been grinded.

Grind valve seat again if necessary.

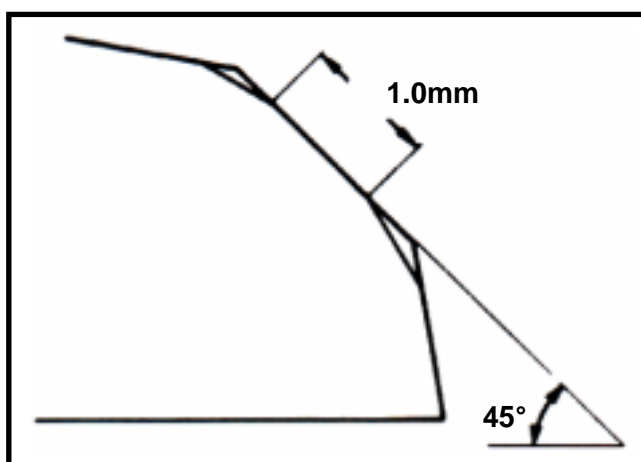
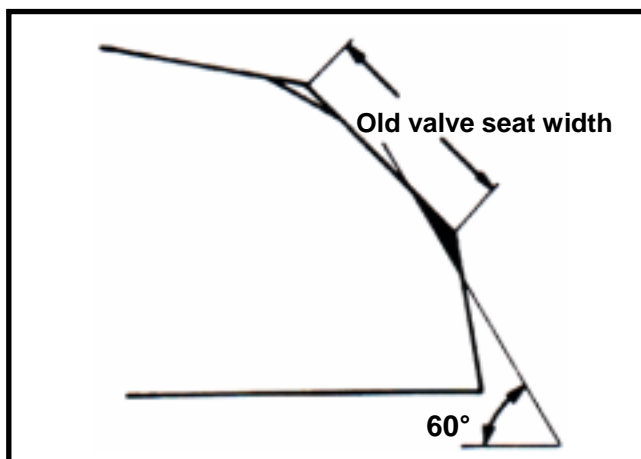
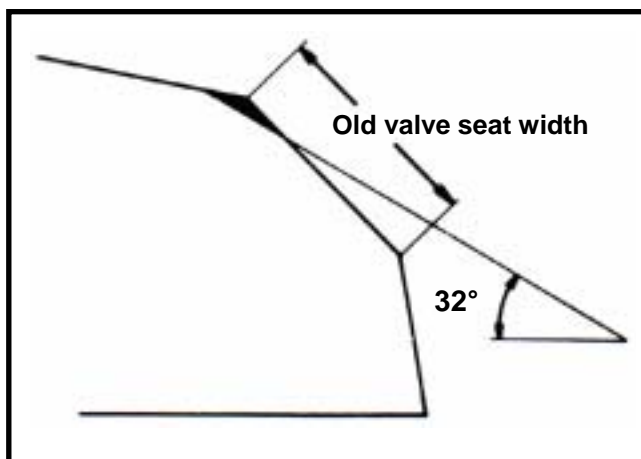
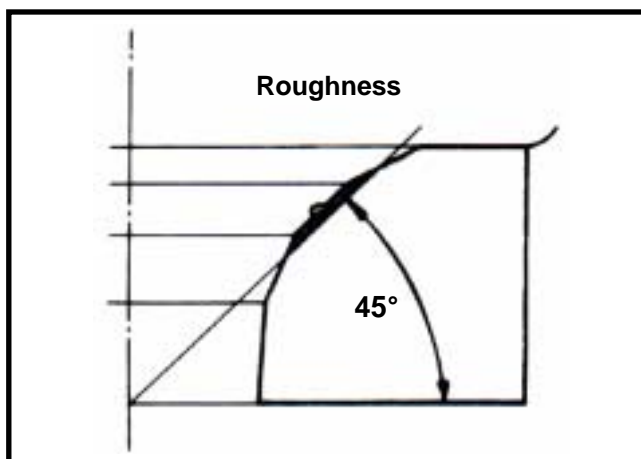

6. Cylinder Head/Valve

Coat the valve seat surface with red paint. Install the valve through valve guide until the valve contacting with valve seat, slightly press down the valve but do not rotate it so that a seal track will be created on contact surface.

⚠ Caution

The contact surfaces of valve and valve seat are very important to the valve sealing capacity.

If the contact surface too high, grind the valve seat with 32° cutter. Then, grind the valve seat to specified width.

If the contact surface too low, grind the valve seat with 60° cutter. Then, grind the valve seat to specified width.

After the valve seat grinded, coat valve seat surface with emery and then slightly press the grinded surface. Clean up all emery coated onto cylinder and valve after grinded.

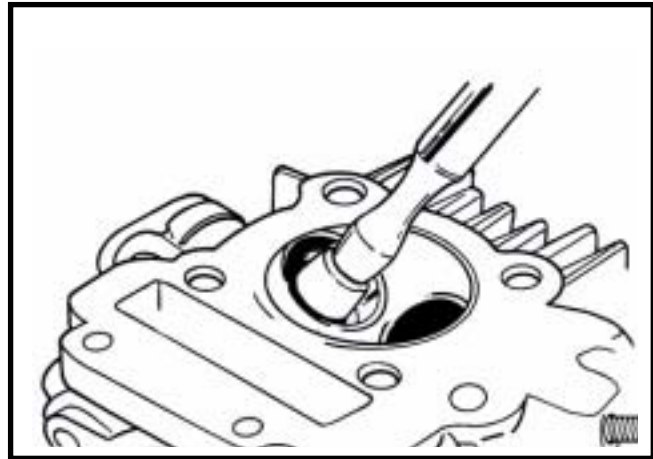
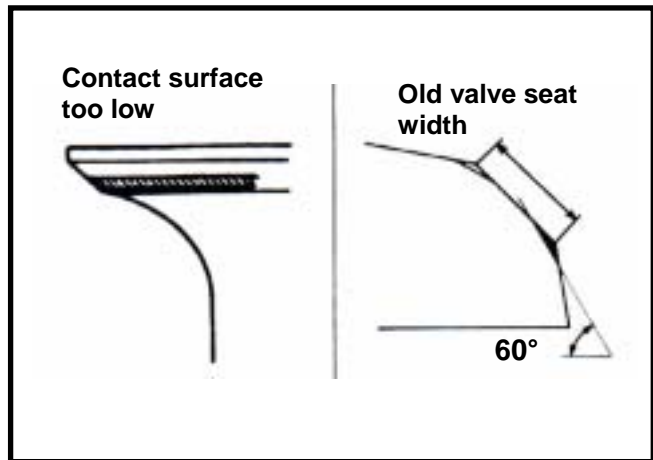
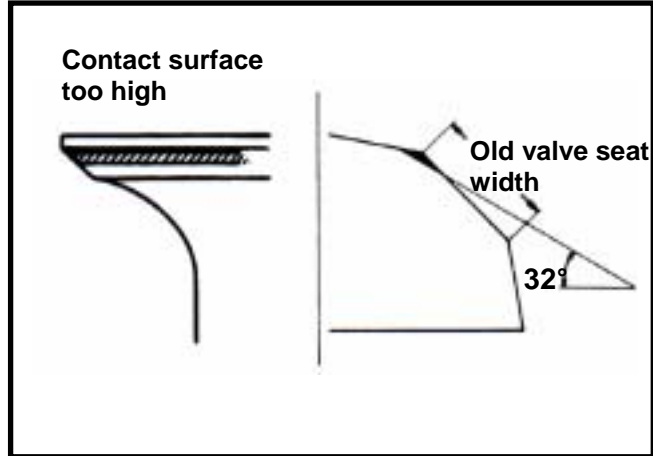

Cylinder Head Reassembly

Lubricate valve stem with engine oil, and then insert the valve into valve guide. Install new valve stem oil seal. Install valve springs and retainers.

⚠ Caution

The closed coils of valve spring should face down to combustion chamber.

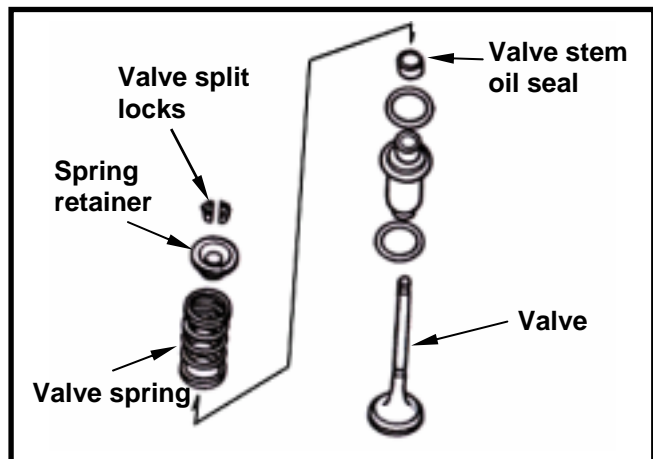

Use valve spring compressor to press valve spring.
Install valve split locks and release the valve compressor.

⚠ Caution

In order to avoid losing spring elasticity, do not press the spring too much. Thus, press length is based on the valve split locks in which can be removed.

Special Service Tool: Valve spring compressor



Or with the valve spring remover/installer to install valve and spring.
Firstly, install valve spring, retainers onto the valve as assembling.

⚠ Caution

In order to avoid damaging the valve stem and the cylinder head, in the combustion chamber place a rag between the valve spring remover/installer as compressing the valve spring directly.



With the valve spring remover/installer, compress the valve spring directly. Then, remove the valve and valve spring.

Special Service Tool: Valve spring remover/installer.



Tap valve stem to make valve retainer and valve stem sealing properly.

⚠ Caution

Place and hold cylinder head on to working table and place a rag against onto the valve so that can prevent damage valve stem and cylinder head.

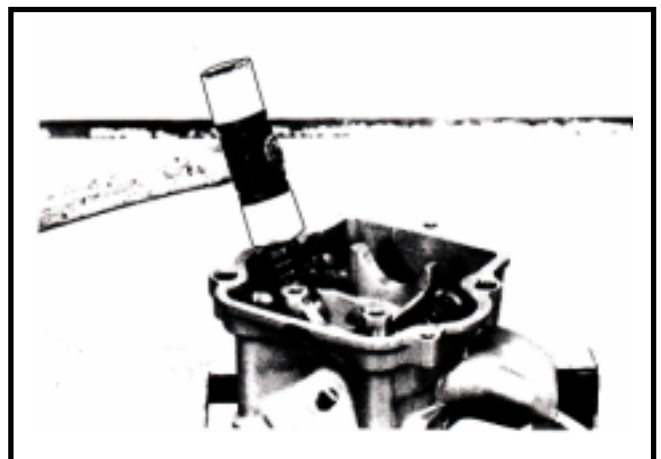

6. Cylinder Head/Valve

Install the camshaft onto the cylinder head and then the rocker arm and the rocker arm shaft. Lock the lock plate after rotate the rocker arm shaft to properly position.

Caution

There is different shapes on the top-end of rocker arm shaft. The machined surface on the rocker arm shaft has to face toward exhaust side, and then the larger surface has to align with the bolt hole of cylinder

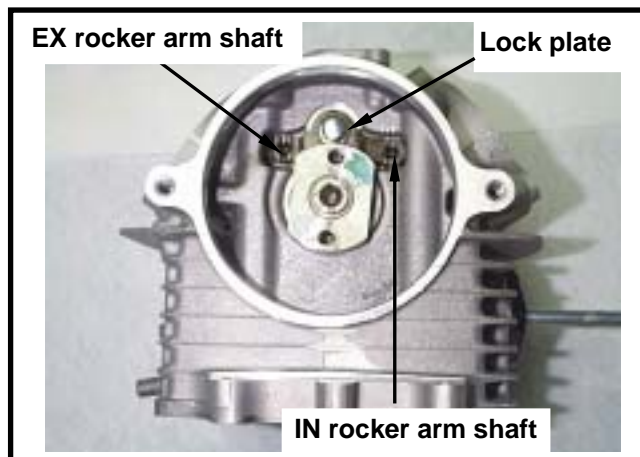

Cylinder Head Installation

Install the lock pins and new cylinder head gasket onto the cylinder head. Install the camshaft chain plate.

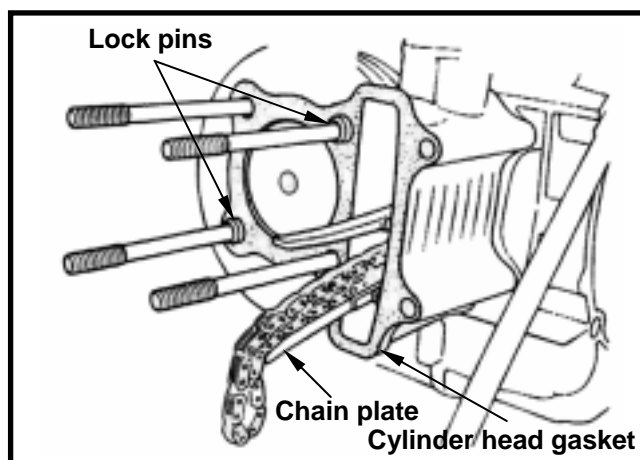

Install the cylinder head. Tighten the 4 nuts onto the cylinder head top-end, and then the 2 cylinder head mounting bolts on its side.

Torque value: 2.0~2.4 kgf-m

Caution

This model is equipped with precious 4 valves mechanism so tighten torque can not be over the limited value and tightening the bolts diagonally by 2-3 sequences. It can prevent from cylinder head deformation and then cause noise or leaking problems so that effect motorcycle's performance.

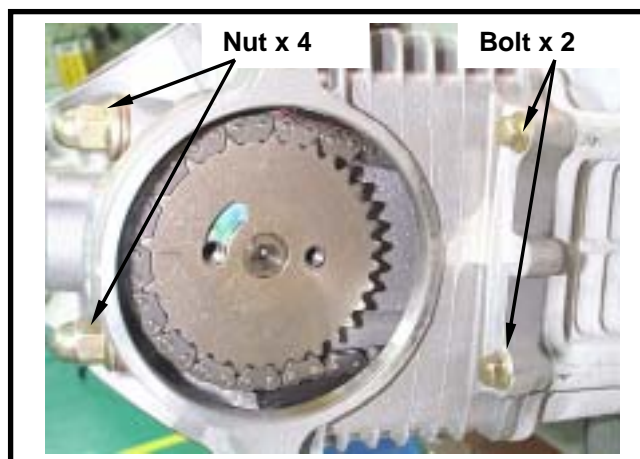

With T type wrench to turn crankshaft in a clockwise motion so that the "T" mark on the alternator flywheel aligns with the mark on crankcase. (piston is at TDC position) Place the TDC marks of the cam sprocket at same level of the top-end of cylinder head. The other single hole of the cam sprocket is in upward. Then, install the cam chain onto the cam sprocket.

Install the spark plug and tighten it.

Torque value: 1.0~1.2 kgf-m

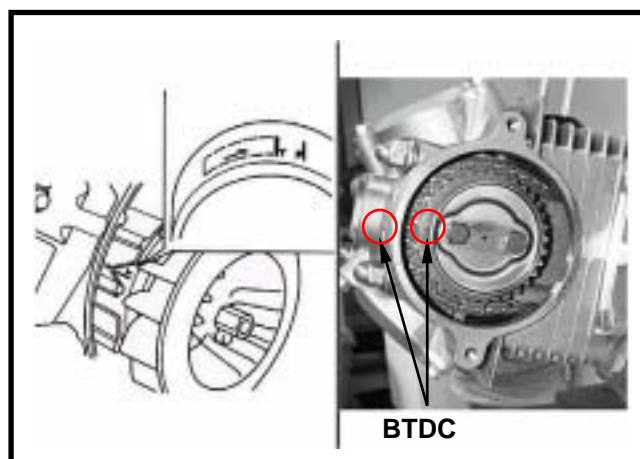

Tighten the cylinder head right side cover. (bolt x 2)

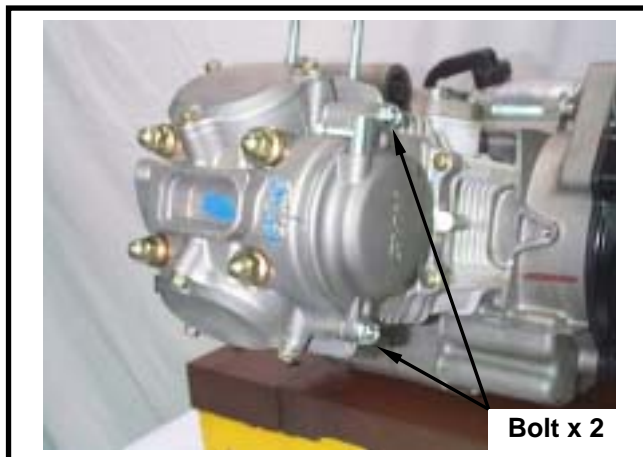

With flat screwdriver, turn the cam sprocket tensioner in counter-clockwise motion so that the tensioner is pushed out to contact the cam chain plate tightly. Apply with oil onto a new O-ring and then install it onto the tensioner hole. Tighten the bolt cap of the tensioner adjustment hole.

Caution

The O-ring must be installed into glove.



Install the left-side cover of the engine body. (bolt x 1)

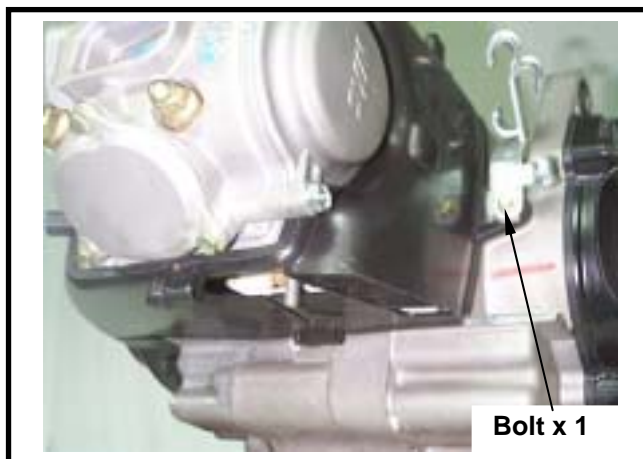

Install the right-side cover of the engine body. (screw x 4)

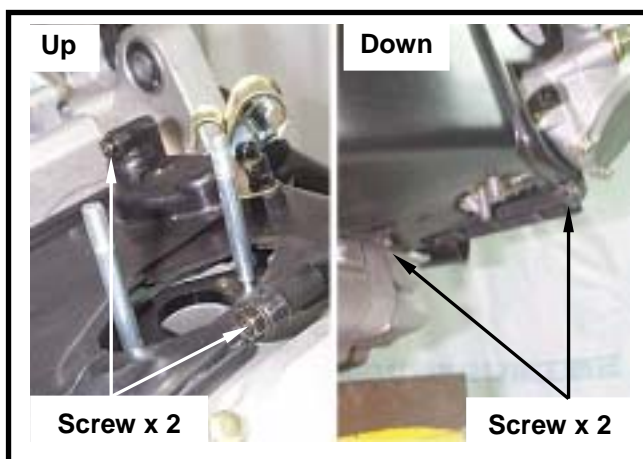

6. Cylinder Head/Valve

Install the cooling fan cover. (screw x2, bolt x 2)

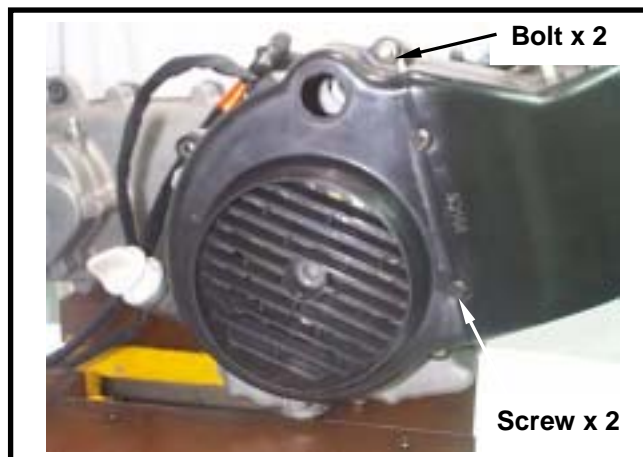

Valve Clearance Adjustment

Loosen valve clearance adjustment nuts and bolts located on valve rocker arm. Measure and adjust valve clearance with feeler gauge.

After valve clearance had been adjusted to standard value, hold adjustment bolt and then tighten the Adjustment nut.

Standard Value: IN 0.12 ± 0.02 mm
EX 0.12 ± 0.02 mm

Install the valve clearance adjustment hole cap. (bolt x2)



Start the engine after assembly. Remove the intake valve adjustment hole cap and make sure that engine oil flows onto the cylinder head. Stop the engine after confirmed, and then install the intake valve adjustment hole cap. Install the seat cushion and the central cover.

Caution

- The cylinder components will be serious wear out if lubricant did not flow onto the cylinder head. So it has to be confirmed.
- It has to be in idle speed when conduct this procedure. Never increase engine speed in high RPM.



Mechanism Illustration	7-1	Piston Removal	7-5
Precautions In Operation	7-2	Piston Inspection	7-5
Trouble Diagnosis.....	7-2	Piston Ring Installation	7-7
Cylinder Removal.....	7-3	Piston Installation	7-8
Cylinder Inspection.....	7-4	Cylinder Installation.....	7-8

Mechanism Illustration

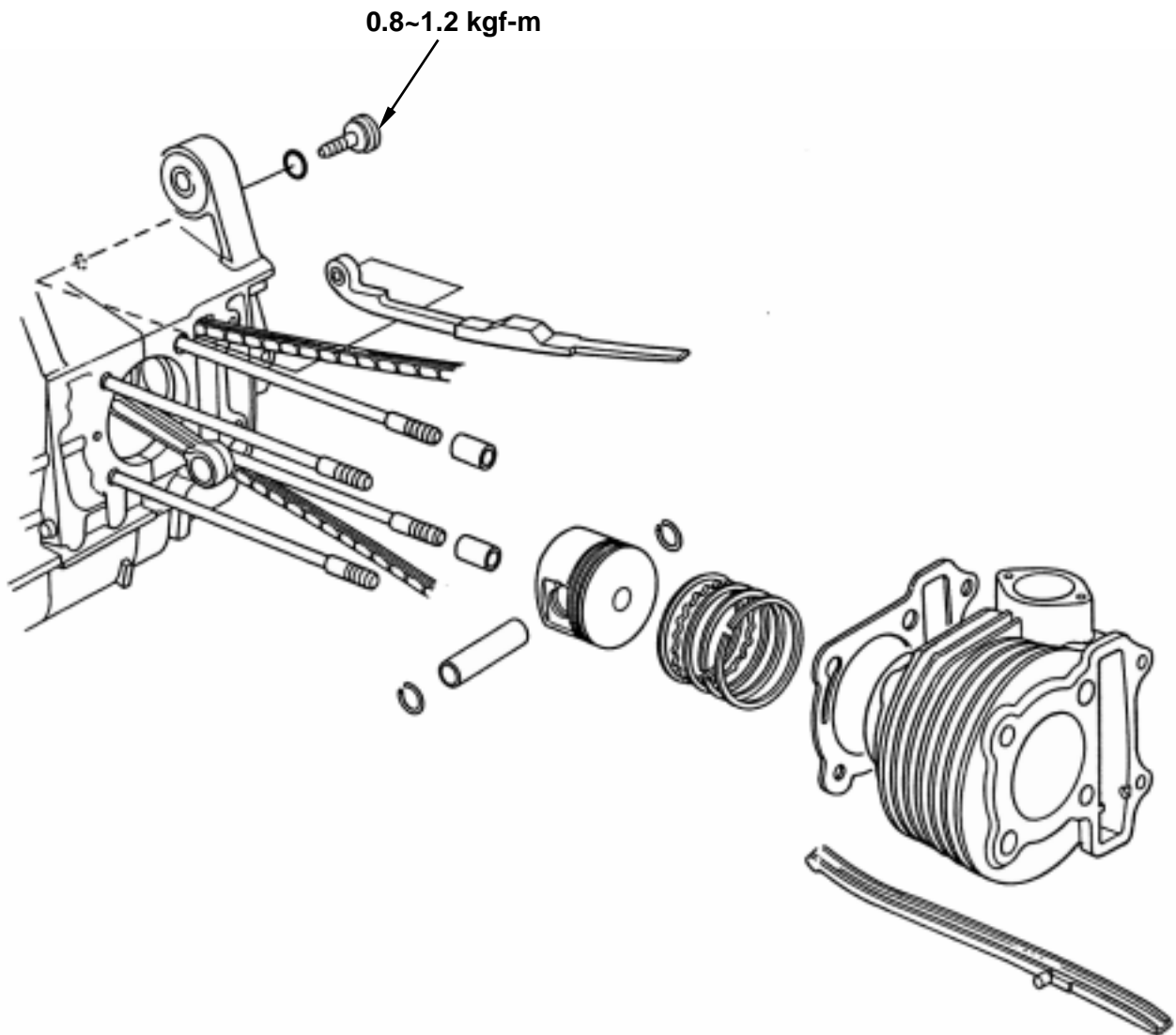

7. Cylinder/Piston

Precautions In Operation

General Information

Both cylinder and piston service cannot be carried out when engine mounted on frame.

Specification

Unit: mm

Item		Standard	Limit	
Cylinder	ID	57.400~57.410	57.500	
	Bend/wrapage	-	0.050	
	Cylindrical roundness	-	0.050	
	Cylindrical roundness	-	0.050	
Piston/Piston ring	Clearance between piston rings	Top ring	0.025~0.060	0.090
		2 nd ring	0.015~0.050	0.090
	Ring-end gap	Top ring	0.100~0.250	0.500
		2 nd ring	0.250~0.400	0.650
		Oil ring side rail	0.200~0.800	-
	OD of piston		57.370~57.390	57.300
	Piston OD measurement position		Lower-end up 9mm of piston skirt	-
	Clearance between piston and cylinder		0.010~0.040	0.100
ID of piston pin boss		15.002~15.008	15.040	
OD of piston pin		14.994~15.000	14.960	
Clearance between piston and piston pin		0.002~0.014	0.020	
ID of connecting rod small-end		15.016~15.034	15.060	

Trouble Diagnosis

Low Or Unstable Compression Pressure

- Cylinder or piston ring worn out

High Compression Pressure

- Carbon deposit onto the piston & combustion chamber

Knock or Noise

- Cylinder or piston ring worn out
- Carbon deposits on cylinder head top-side
- Piston pin hole and piston pin wear out

Smoking in Exhaust Pipe

- Piston or piston ring worn out
- Piston ring installation improperly
- Cylinder or piston damage

Engine Overheat

- Carbon deposits on cylinder head top side

Cylinder Removal

Remove cylinder head. (refer to chapter 6)
Remove 2 bolts and then take out the cam chain auto-tensioner.

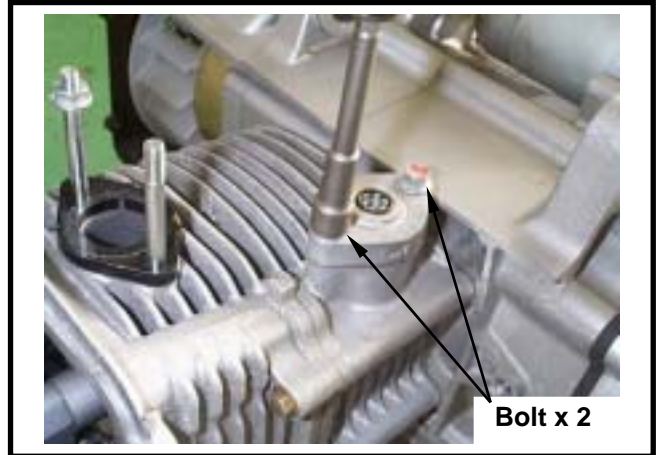

Remove cam chain plate.
Remove cylinder.



Remove cylinder gasket and lock pins.



Clean the residues attached onto the matching surfaces of cylinder and crankcase.



7. Cylinder/Piston

Cover the holes of crankcase and cam chain with a piece of cloth.
Clean up all residues or foreign materials from the two matching surfaces of cylinder and crankcase.

⚠ Caution

To soap the residues into solvent so that the residues can be removed more easily.

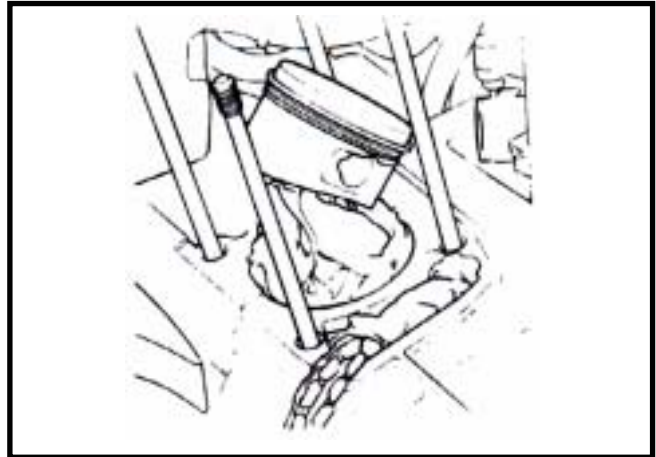

Cylinder Inspection

Check if the inner diameter of cylinder is worn out or damaged.

In the 3 positions (top, center and bottom) of cylinder, measure the X and Y direction values respective in the cylinder.

Service limit: 57.50 mm

Calculate both the real roundness (the difference between X and Y motion values) and the cylindrical roundness (the difference in the top, center or bottom positions of X or Y motion values.) Then, determinate by the max. value.

Service limit:

Real roundness: correct or replace as over 0.05 mm

Cylindrical roundness: correct or replace as over 0.05 mm

Check Cylinder Wrapage.

Service limit: correct or replace as over 0.05 mm

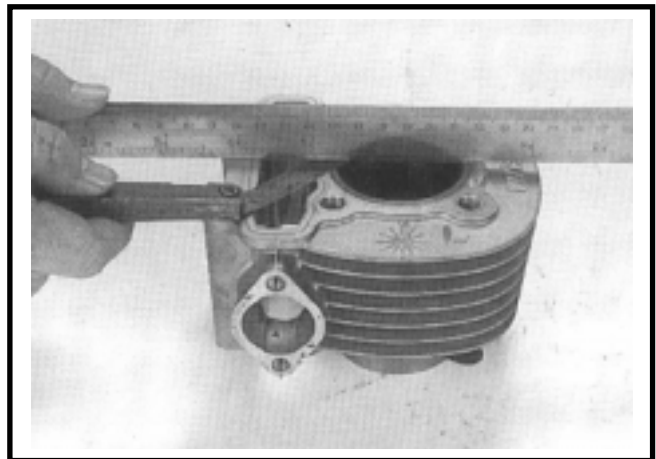
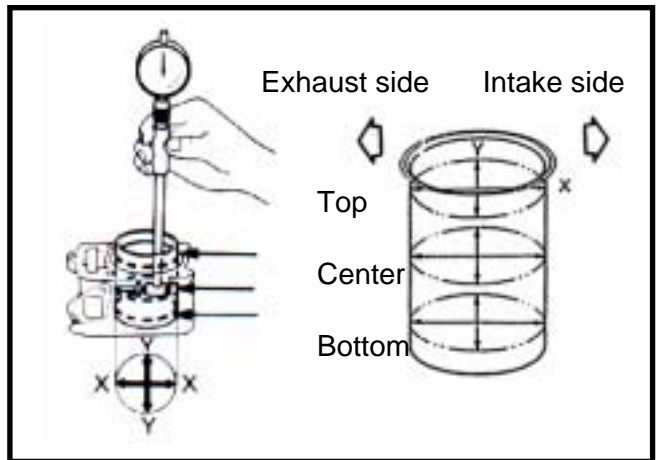

Piston Removal

Plug crankcase opening with a cleaning cloth to prevent from piston pin snap ring or other parts falling into crankcase when disassembling.
 Hold another snap ring with pliers.
 Push out the piston pin from the side that not removed the snap ring.

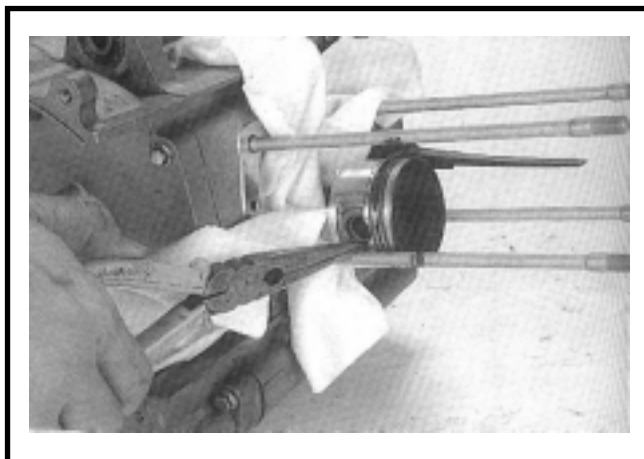

Remove piston rings.

⚠ Caution

Pay attention to remove piston rings because they are fragile.

Disassemble the piston rings.
 Check if the piston rings are damaged or its grooves are worn.
 Clean out the carbon deposit around the piston ring groove.



Piston Inspection

Install the piston rings and then measure clearance between piston ring and its grooves.

Service Limit:

Top ring: replace if over 0.09 mm
2nd ring: replace if over 0.09 mm

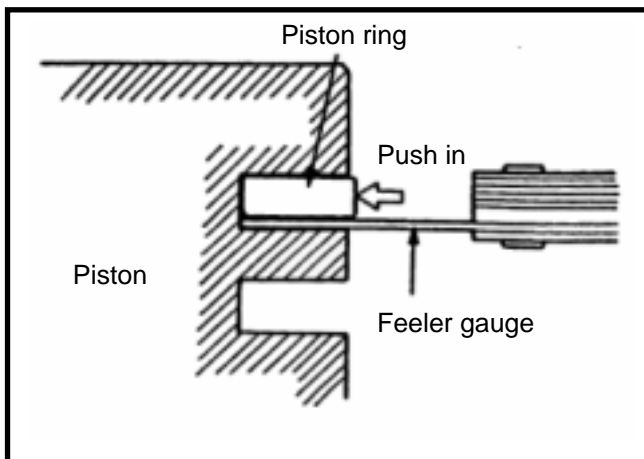

Take out the piston rings and place them respective into cylinder below 20mm of cylinder top. Measure each piston ring gaps.

⚠ Caution

Push the piston rings into cylinder with piston top-end in parallel motion.

Service Limit:

Top ring: replace if over 0.5 mm
2nd ring: replace if over 0.65 mm

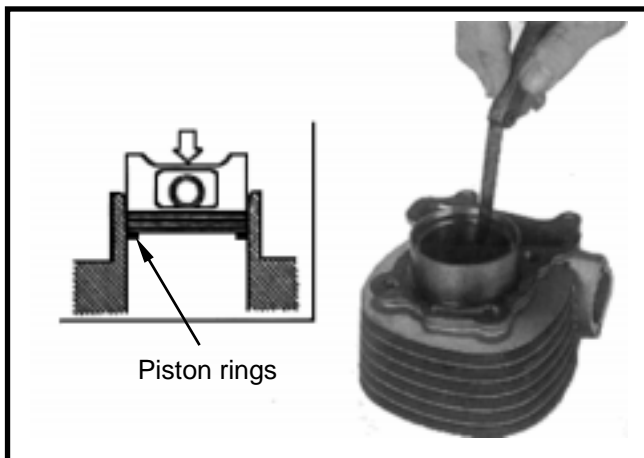

7. Cylinder/Piston

Measure the outer diameter of piston pin.

Service Limit: 14.96 mm

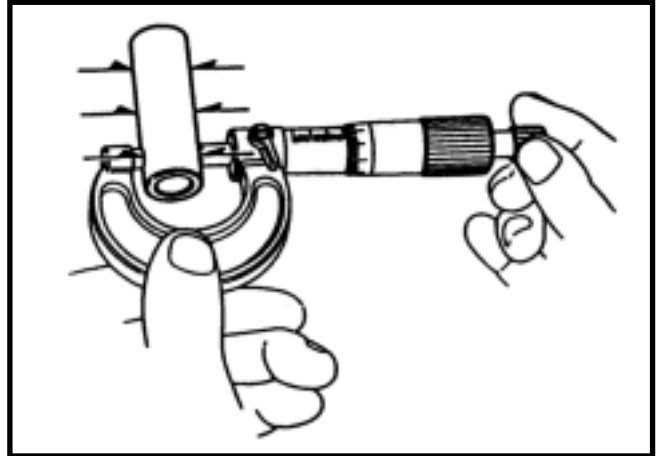

Measure the inner diameter of connecting rod small end.

Service Limit: 15.06 mm

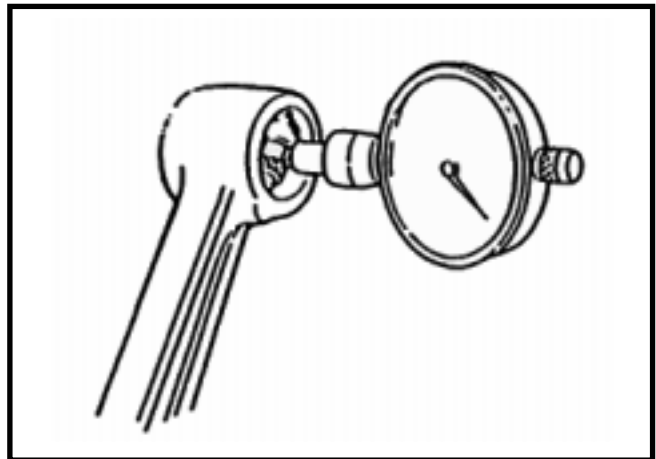

Measure the inner diameter of piston pin hole.

Service Limit: 15.04 mm

Calculate clearance between piston pin and its hole.

Service Limit: 0.02 mm

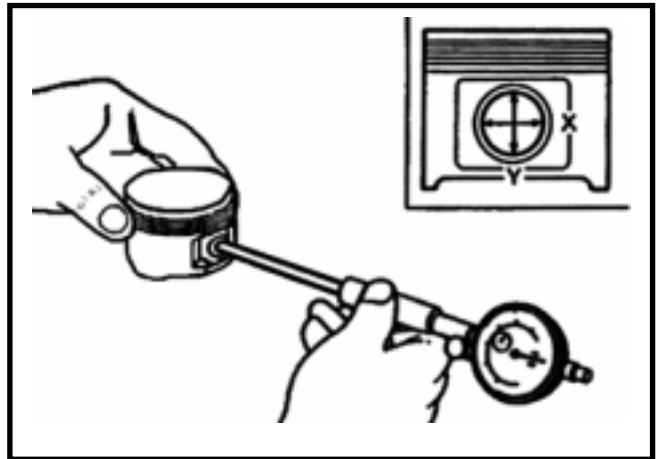

Measure piston outer diameter.

⚠ Caution

The measurement position is 10 mm distance from piston bottom side, and 90° to piston pin.

Service limit: 57.30 mm

Compare measured value with service limit to calculate the clearance between piston and cylinder.

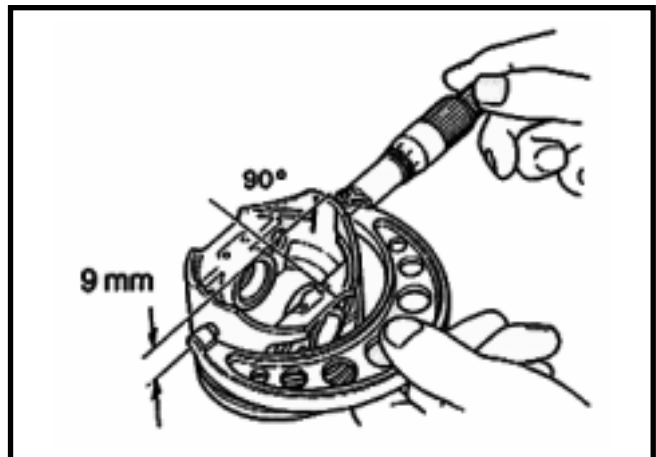

Piston Ring Installation

Clean up piston top, ring groove, and piston skirt.
Install the piston ring onto piston carefully.
Place the openings of piston ring as diagram shown.

⚠ Caution

- Do not damage piston and piston rings as installation.
- All marks on the piston rings must be forwarded to up side.
- Make sure that all piston rings can be rotated freely after installed.

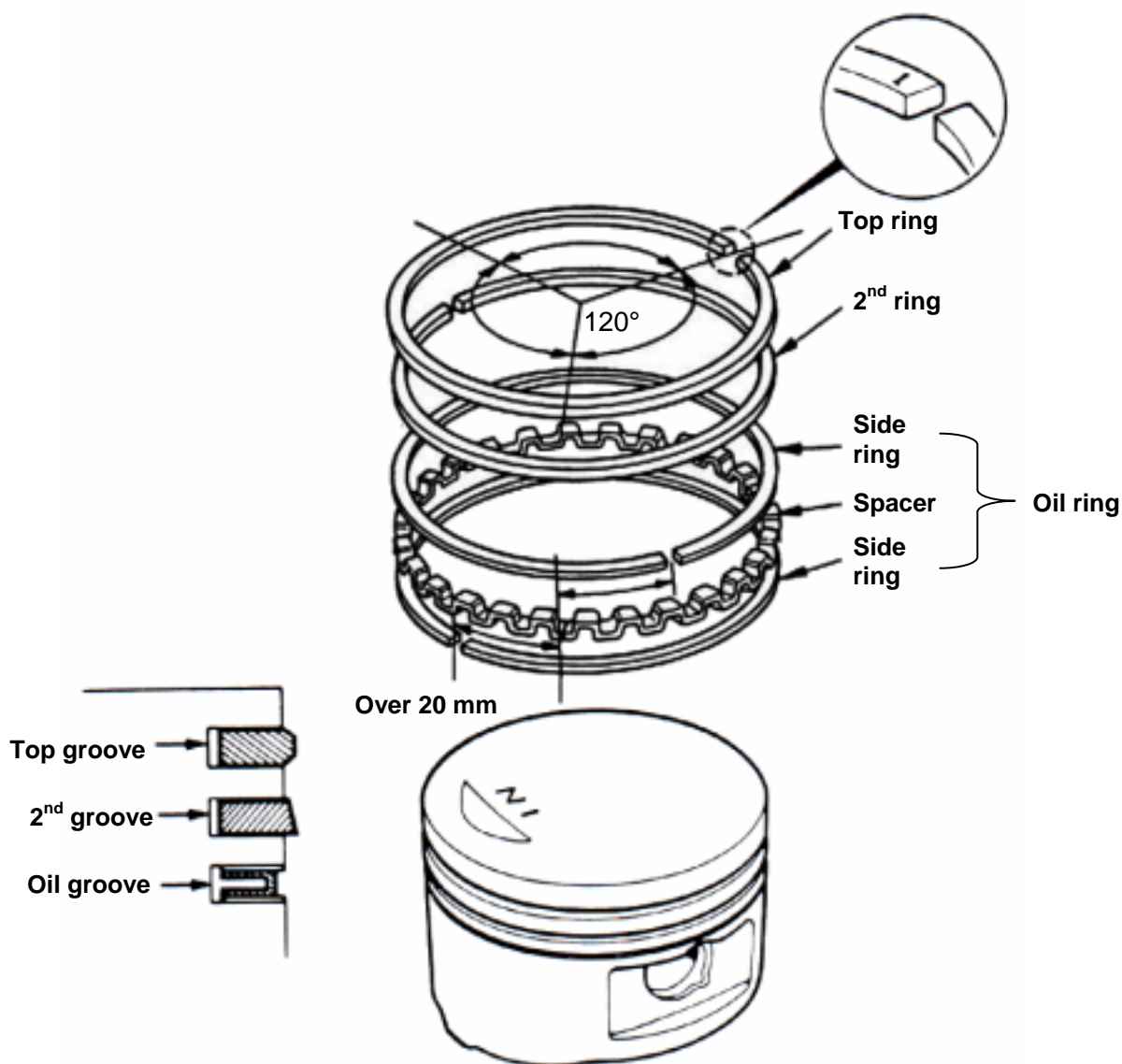

7. Cylinder/Piston

Piston Installation

Install piston and piston pin, and place the IN marks on the piston top side forward to intake valve.

Install new piston pin snap ring.

Caution

- Do not let the opening of piston pin snap ring align with the opening piston ring.
- Place a piece of cloth between piston skirt section and crankcase in order to prevent snap ring from falling into crankcase as operation.

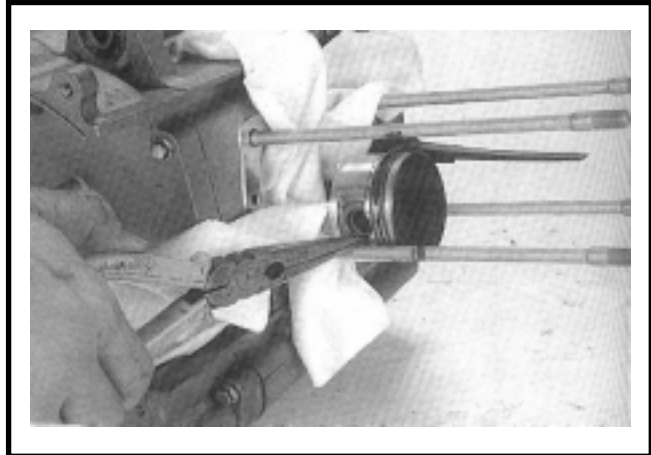

Cylinder Installation

Clean up all residues and foreign materials on the matching surface of crankcase. Pay attention to not let these residues and foreign materials fall into crankcase.

Caution

To soap the residues into solvent so that the residues can be removed more easily.

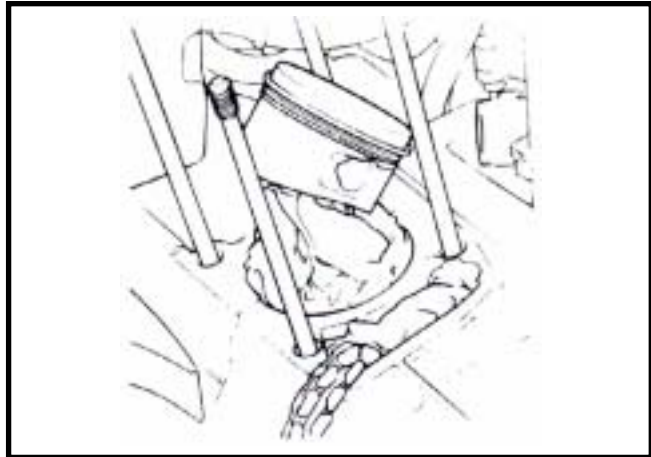

Install 2 lock pins and new gasket.

Coat engine oil to inside of cylinder, piston and piston rings.

Care to be taken when installing piston into cylinder. Press piston rings in one by one as installation.

Caution

Do not push piston into cylinder forcefully because this will cause the piston and the piston rings to be damaged.



Install the cam chain plate, the cylinder gasket and lock pins.

Install cylinder head. (refer to Chapter 6)

Install the cam chain auto-tensioner. (2 bolts)

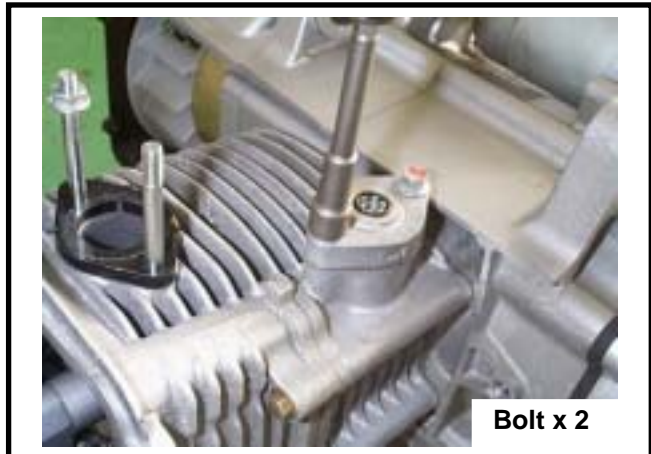

Bolt x 2

8. V-Belt Driving System/Foot Starter

Mechanism Illustration.....	8-1	Foot Starter	8-3
Maintenance Description	8-2	Driving Belt	8-4
Trouble Diagnosis	8-2	Sliding Pulley.....	8-6
Left Crankcase Cover.....	8-3	Clutch/Driven Pulley	8-9

Mechanism Illustration

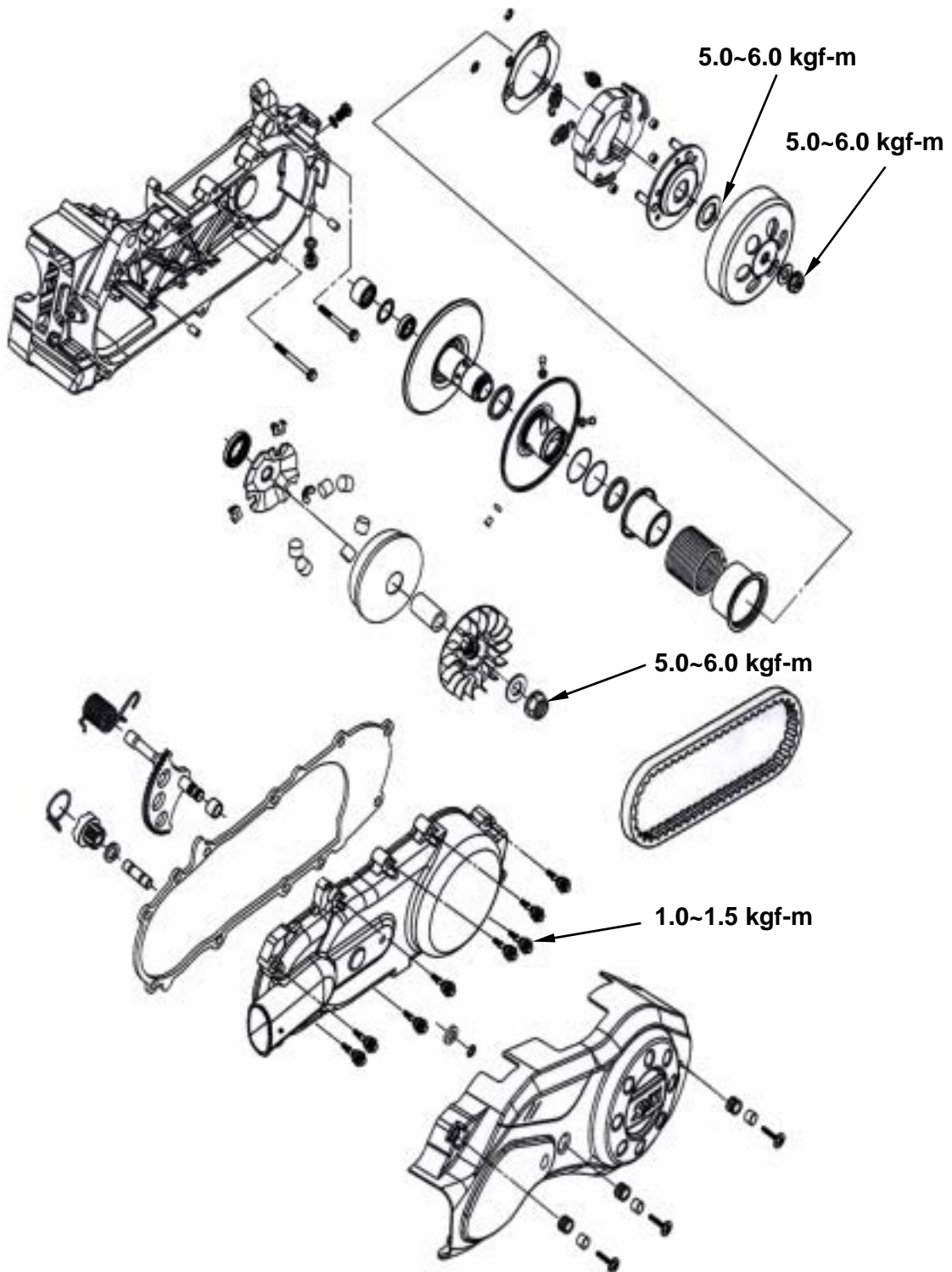

8. V-Belt Driving System/Foot Starter

Maintenance Description

PRECAUTIONS IN OPERATION

- Driving pulley, clutch, and driven pulley can be serviced on the motorcycle.
- Driving belt and driving pulley surface must be free of grease.

Specification

Unit: mm

Item	Standard value	Limit
Driving belt width	19.500	18.500
ID of sliding pulley bushing	27.000~27.021	27.060
OD of sliding pulley hub	26.970~26.990	26.940
OD of weight roller	19.950~20.100	19.500
ID of clutch jacket	130.000~130.200	130.500
Thickness of clutch lining	4.000~4.100	2.000
Free length of driving pulley spring	128.400	123.400
OD of driving pulley	33.965~33.985	33.940
ID of sliding pulley	34.000~34.025	34.060

ID: Inner Diameter

OD: Outer diameter

Torque value

Sliding pulley nut: 5.0~6.0 kgf-m

Clutch jacket nut: 5.0~6.0 kgf-m

driving pulley nut: 5.0~6.0 kgf-m

Special Service Tools

Clutch spring compressor

Bearing puller (inner type)

Clutch mounting nut wrench

Universal fixture

Trouble Diagnosis

Engine can be started but motorcycle can not be moved

1. Worn driving Belt
2. Worn tilt plate
3. Worn or damaged clutch lining
4. Broken driven pulley

Insufficient horsepower or poor high speed performance

1. Worn driving belt
2. Insufficient spring capacity of driven pulley
3. Worn roller
4. Driven pulley operation un-smoothly

Shudder or misfire when driving

1. Broken clutch lining
2. Worn clutch lining



8. V-Belt Driving System/Foot Starter

Left Crankcase Cover

Removal of Crankcase Cover

Remove body cover.

Remove foot starter lever. (bolt x 1)

Remove the outer cover of engine left-side cover. (screw x 3)

Loosen vent strap on the front-left side of cover, and then remove the vent.

Remove air cleaner. (bolt x 2)

Remove the engine left-side cover. (bolt x 8)

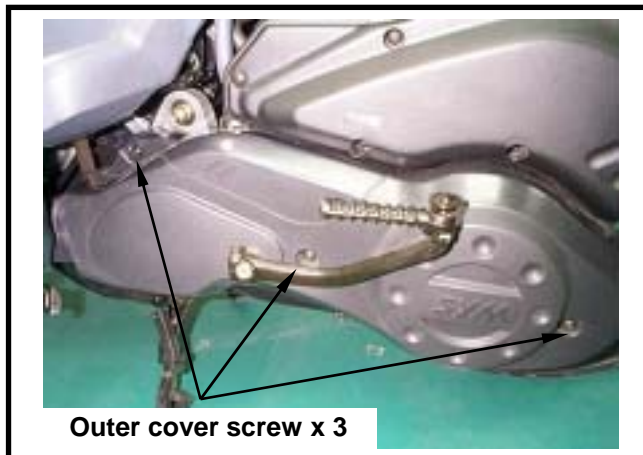

Foot Starter

Disassembly

Remove snap ring and thrust washer from engine left-side cover.

Install foot starter lever, rotate the lever slightly and then remove driving gear and washer.

Remove the lever, foot starter, starter shaft, and return spring as well as socket.

Inspection

Check if starter shaft, driving gear, socket and bearing hole for wear or damage. Replace it with new one if necessary.

Check the return spring and friction spring for spring force or damaged. Replace it with one if poor parts found.

Reassembly

Install socket, return spring and starter shaft as diagram shown.

Install thrust washer and snap ring onto starter shaft.

Install foot starter lever temporary.

Rotate the lever and then align driving gear with width-tooth on the starter shaft.

Install the friction of driving gear onto convex part of the cover.

Installation of the left crankcase cover

Install the left crankcase cover. (8 screws)

Install front vent tube of left cover and tighten the strap.

Install foot starter lever. (1 bolt)

Tighten the air cleaner. (2 bolts)

Install the body cover.

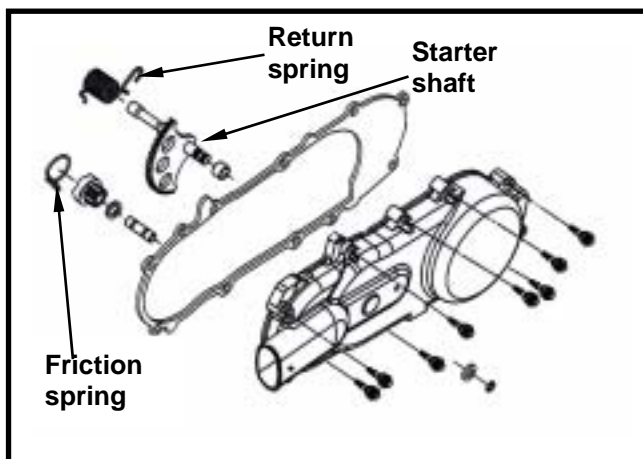
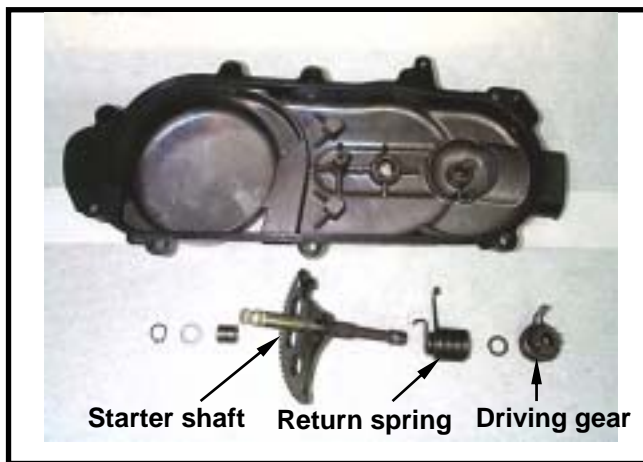

8. V-Belt Driving System/Foot Starter

Driving Belt

Removal

Remove left crankcase cover.
Hold driving pulley with universal fixture, and remove nut and clutch jacket.

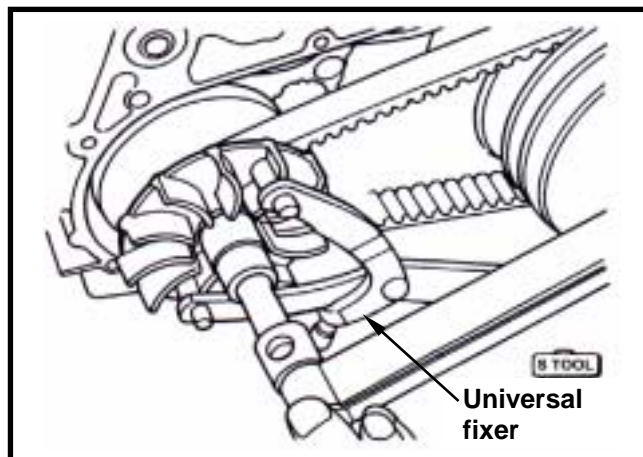

Hold the clutch outer jacket with the universal fixture, and the remove the nut and the clutch outer jacket.

⚠ Caution

Using special service tools for tightening or loosening the nut. Fixed rear wheel or rear brake only will damage reduction gear system.

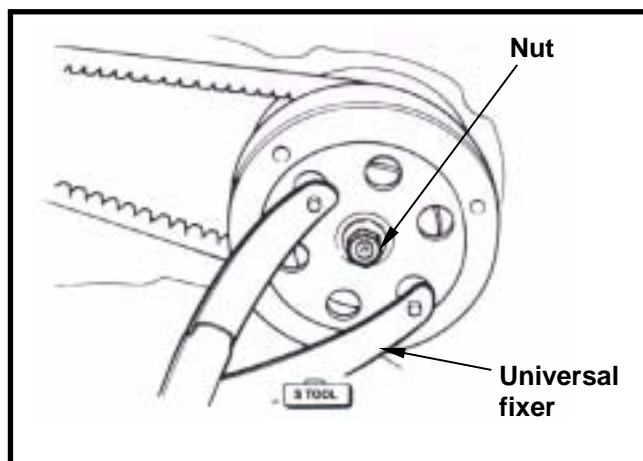

Push the driving belt into belt groove as diagram shown so that the belt can be loosened, and then remove.
Driving belt and clutch at same time.

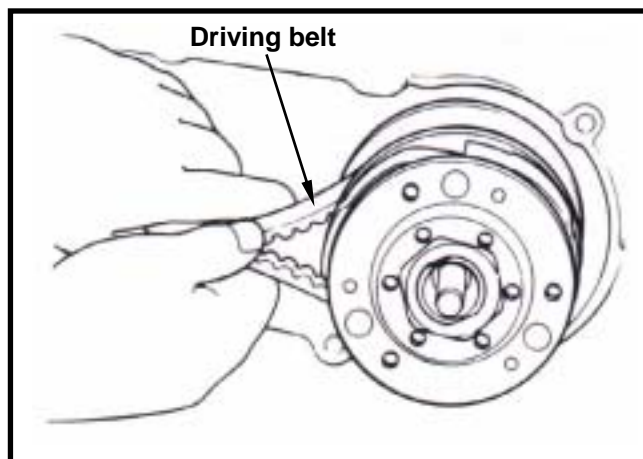

Inspection

Check the driving belt for crack or wear.
Replace it if necessary.
Measure the width of driving belt as diagram shown. Replace the belt if exceeds the service limit.

Service Limit: 18.5 mm

⚠ Caution

- Using the genuine parts for replacement.
- The surfaces of driving belt or pulley must be free of grease.

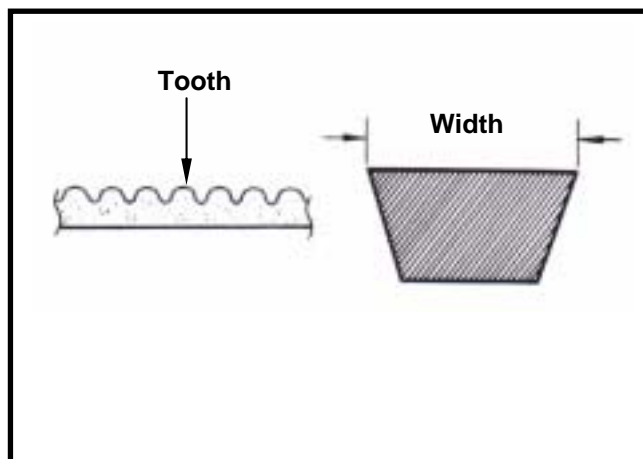



8. V-Belt Driving System/Foot Starter

Installation

Pull out the driving pulley and then insert the driving belt into the driving pulley.

⚠ Caution

Pull out driving pulley and then insert the driving belt into the driving pulley so that the driving belt set can be installed onto sliding pulley more easily.

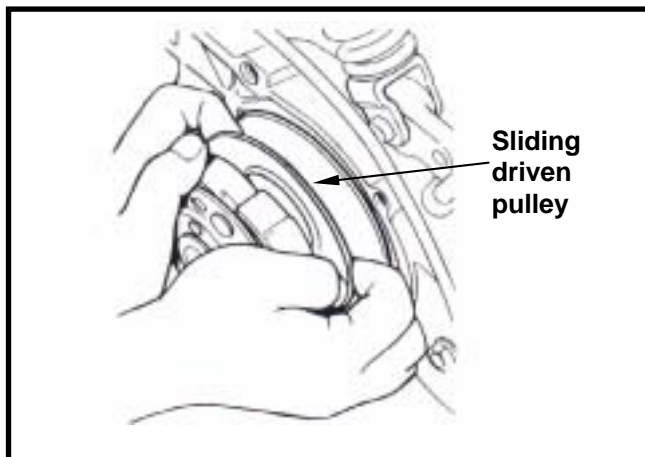

Install the clutch set with driving belt onto the driving shaft.
The other end of belt hook onto the sliding pulley.
Install the clutch outer jacket.

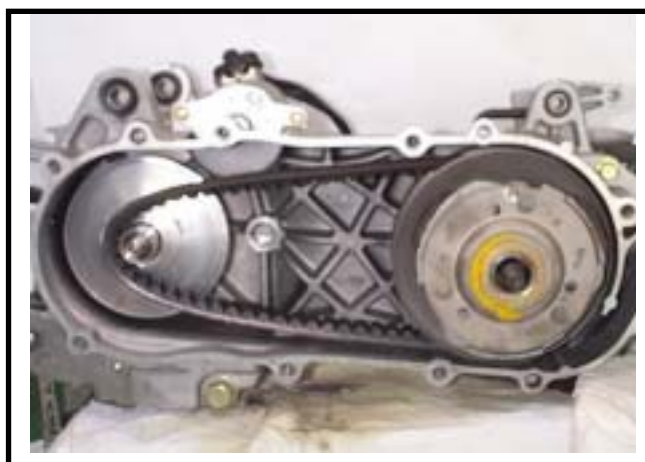

Install the clutch with universal fixture, and then tighten nut to specified torque value.
Torque value: 5.0~6.0 kgf-m

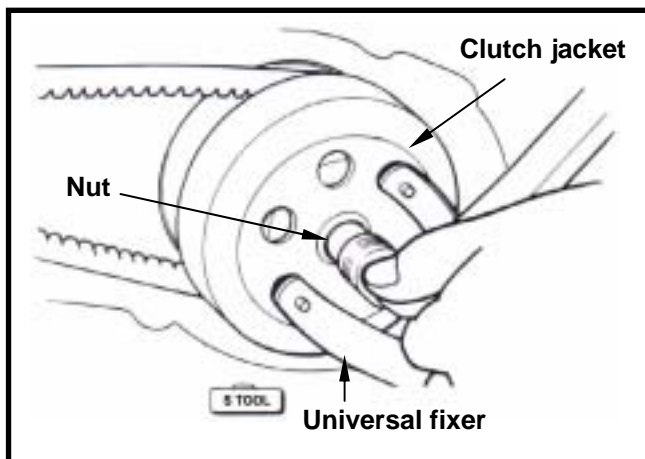

⚠ Caution

When install the driving belt, if there is a arrow mark, then the arrow mark must point to rotation motion. If not, the letters on the belt must be forwarded to assembly direction

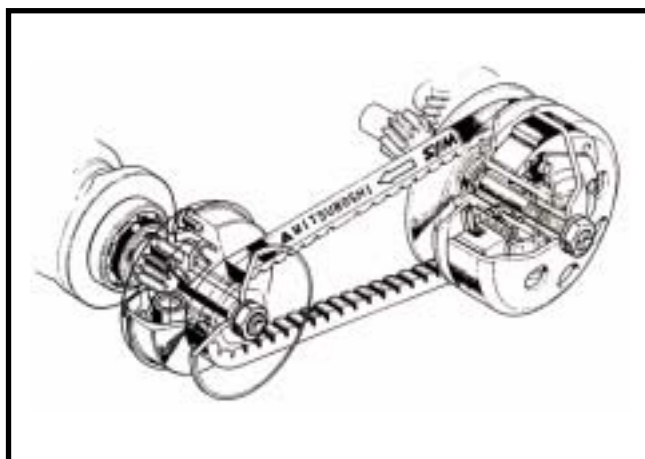

8. V-Belt Driving System/Foot Starter

Sliding Pulley

REMOVAL

Remove left crankcase cover.
Hold driving pulley with universal fixture, and then remove driving pulley nut.
Remove driving pulley.

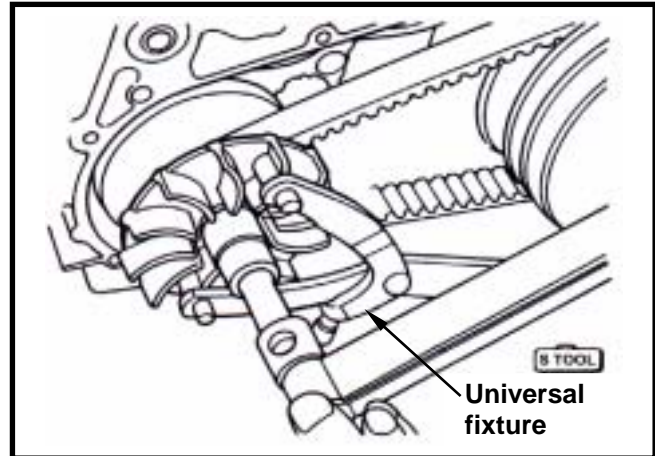

Take out the driving belt from the pulley.
Remove sliding pulley set and driving pulley hub from crankshaft.

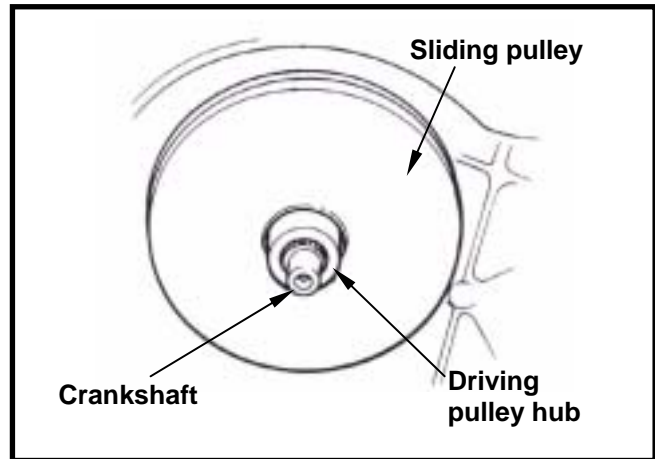

Remove tilt plate.

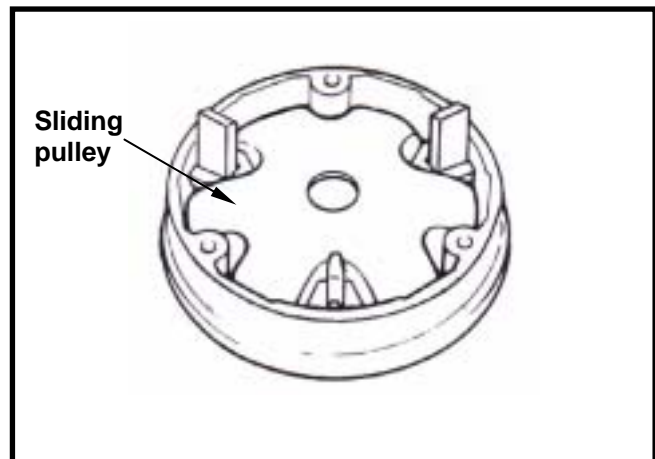

Remove weight rollers from sliding pulley.

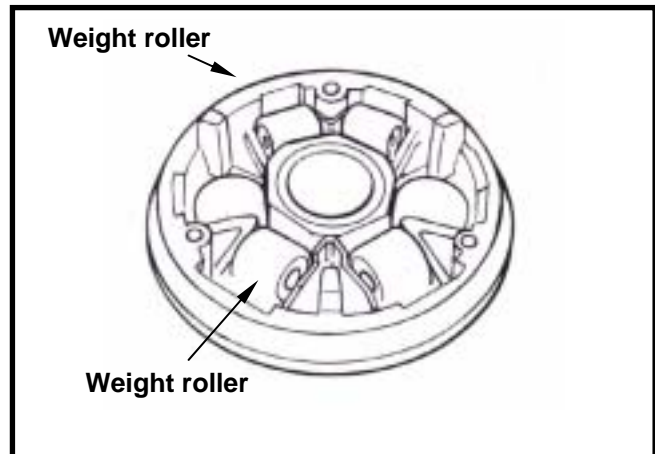

Inspection

The operation of sliding pulley is means of the weight roller to pressing on it with centrifuge force. And then the speed is changed by the title plate rotation. Thus, if weight rollers are wear out or damage, the centrifuge force will be effected.

Check if rollers are wear out or damage.

Replace it if necessary.

Measure each roller's outer diameter. Replace it if exceed the service limit.

Service limit: 19.50 mm

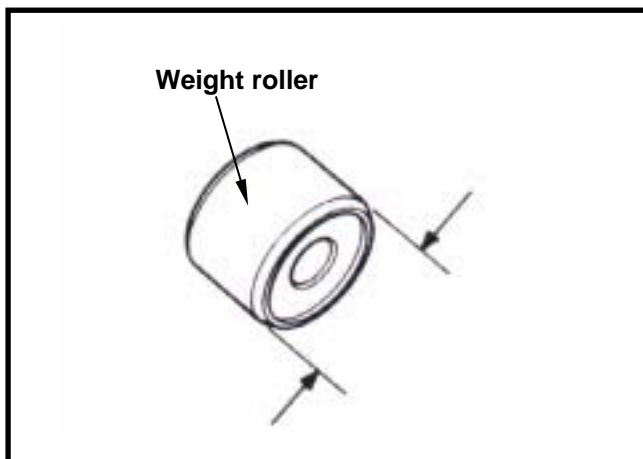

Check the pulley hub if damaged or wear out.

Replace it if necessary.

Measure the pulley hub's outer diameter.

Replace it if exceed the service limit.

Service limit: 23.94 mm

Measure the pulley hub's inner diameter.

Replace it if exceed the service limit.

Service limit: 24.06 mm

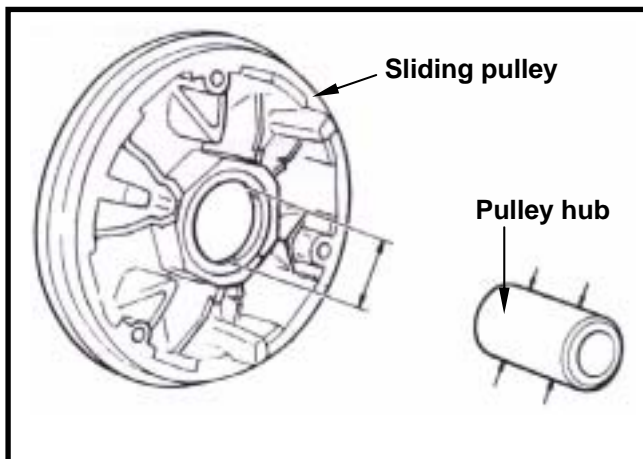

Assembly/Installation

Install the weight roller.

Caution

The both ends of weight roller are different. In order to prolong the roller life span and prevent abnormal wearing out, install the closed end onto the sliding pulley in the movement of CCW.

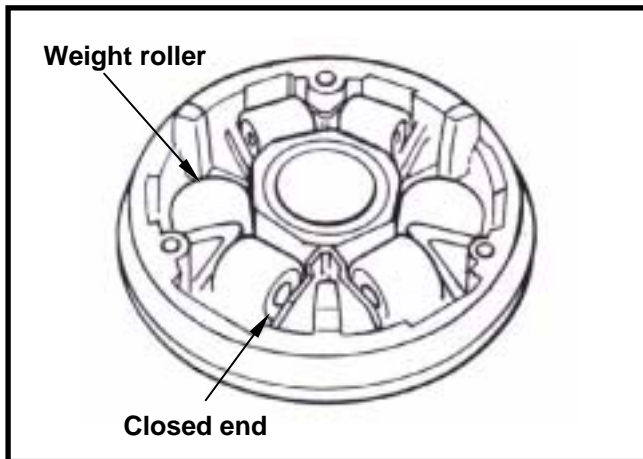

Install the title plate guide boot (3 pieces) onto the title plate.

Install the title plate.

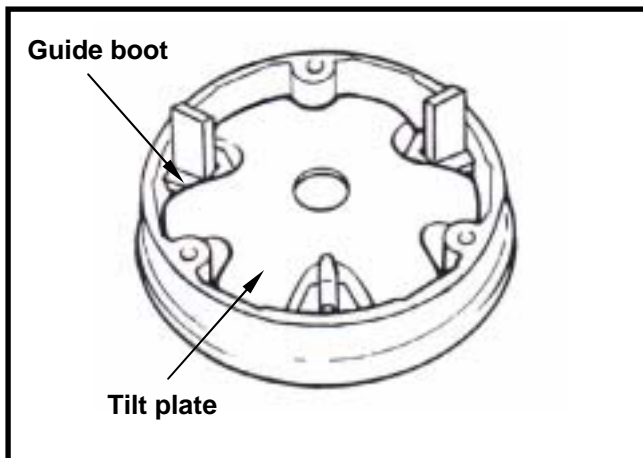

8. V-Belt Driving System/Foot Starter

Apply with grease 4~5 g to inside of driving shaft hole, and install driving pulley hub.

⚠ Caution

The pulley surface has to be free of grease. Clean it with cleaning solvent.

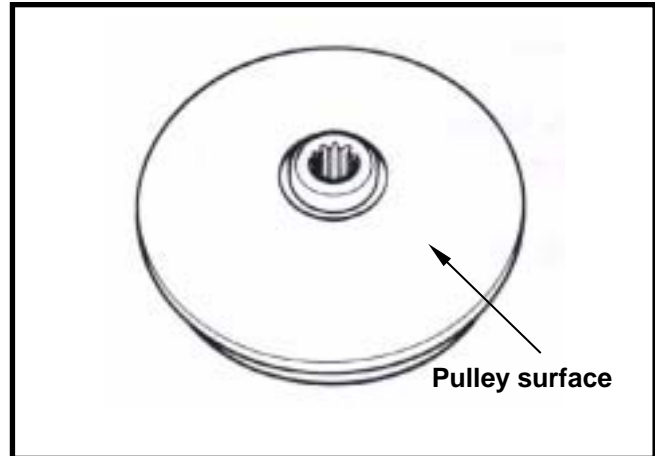

Install sliding pulley assembly onto crankshaft.

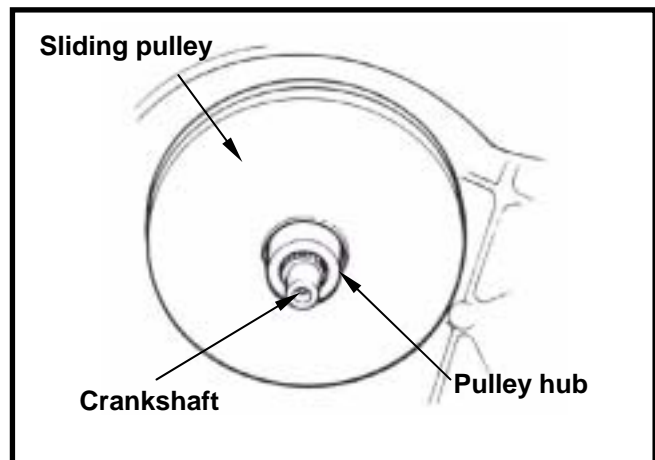

DRIVING PULLEY INSTALLATION

Press driving belt into pulley groove, and then press down the up & down sides of the driving belt to separate it away from the driving pulley hub.

⚠ Caution

To press down the up & down sides of the driving belt can avoid to pressing and damaging the belt when installing the driving pulley, and also can make sure that the driving pulley can be tighten.

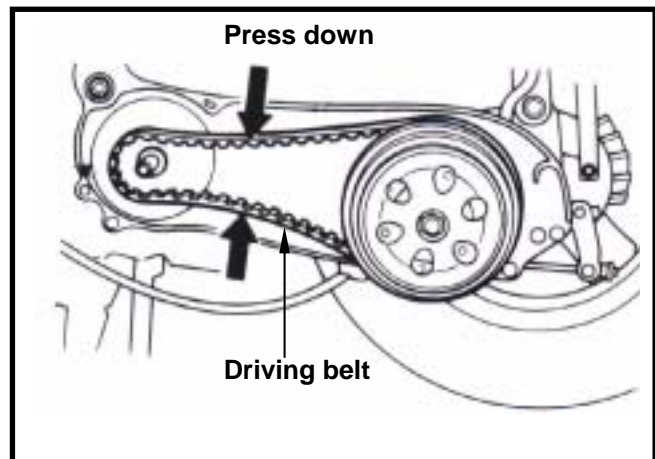

Install driving pulley, washer and nut.

⚠ Caution

Make sure that two sides of pulley surfaces have to be free of grease. Clean it with cleaning solvent.

Hold driving pulley with universal fixture. Tighten nut to specified torque.

Torque value: 5.0~6.0 kgf-m

Install left crankcase cover.

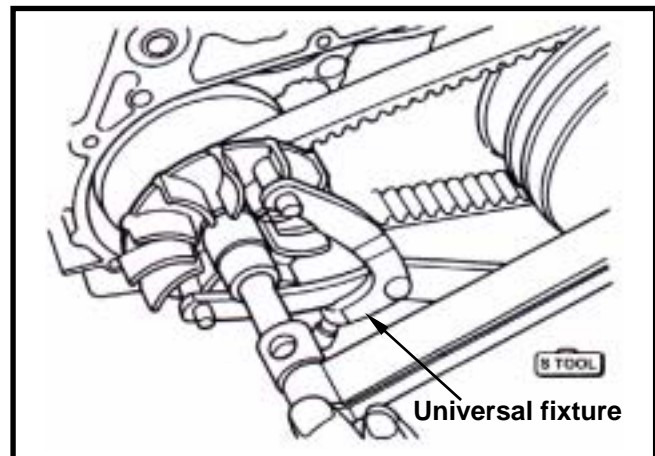



8. V-Belt Driving System/Foot Starter

Clutch/Driven Pulley

DISASSEMBLY

Remove driving belt and clutch/driven pulley. Install clutch spring compressor onto the pulley assembly, and operate the compressor to let nut be installed more easily.

Caution

Do not press the compressor too much.

Hold the clutch spring compressor onto bench vise, and then remove mounting nut with special nut wrench.

Release the clutch spring compressor and remove clutch and spring from driven pulley.

Remove oil seal from driven pulley.

Remove guide pin, guide pin roller, and sliding pulley, and then remove O-ring & oil seal seat from sliding pulley.

INSPECTION

Clutch jacket

Measure the inner diameter of clutch jacket friction face. Replace the clutch jacket if exceed service limit.

Service limit: 130.5 mm

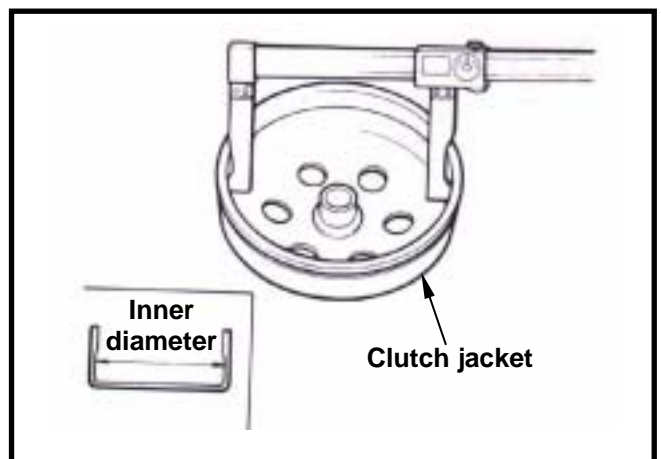
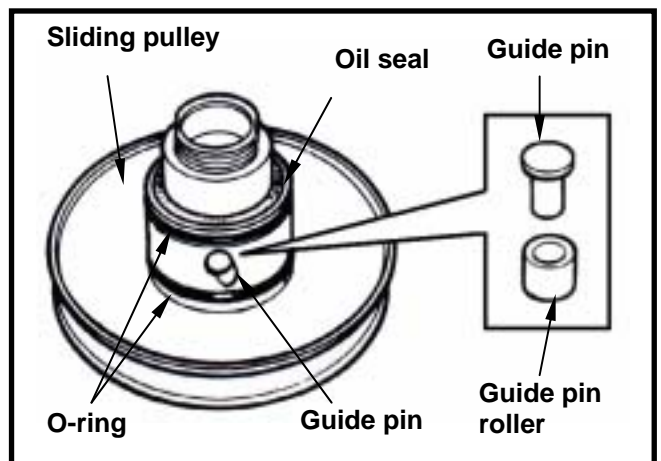
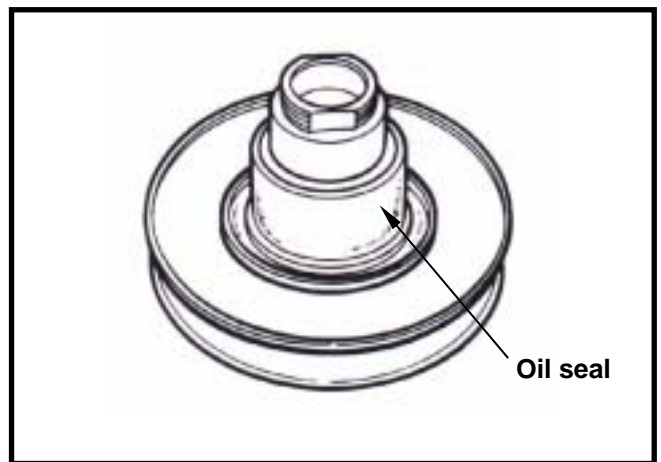
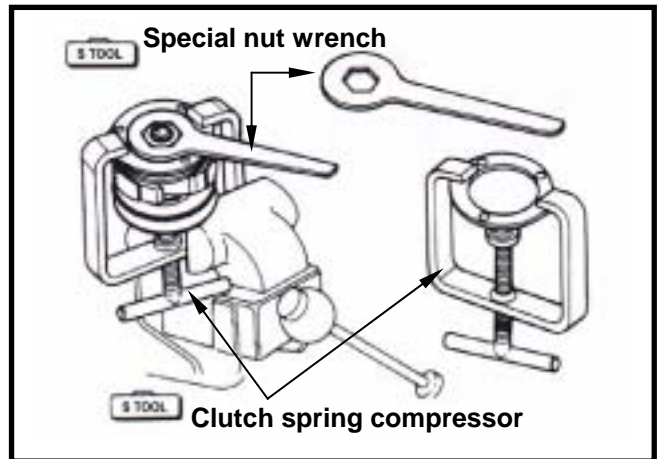

8. V-Belt Driving System/Foot Starter

Clutch lining

Measure each clutch lining thickness. Replace it if exceeds service limit.

Service limit: 2.0 mm

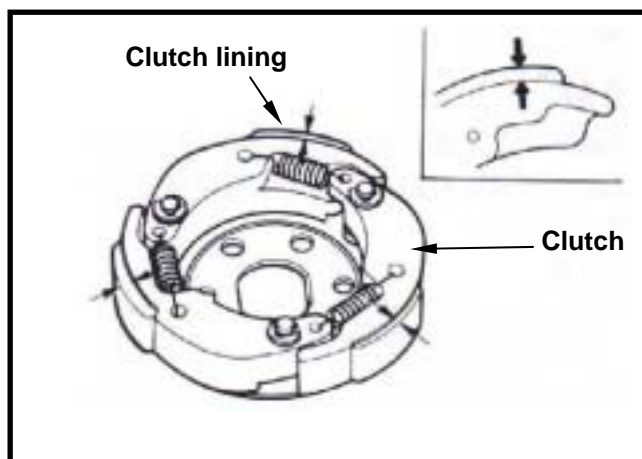

Driven pulley spring

Measure the length of driven pulley spring. Replace it if exceeds service limit.

Service limit: 123.4 mm

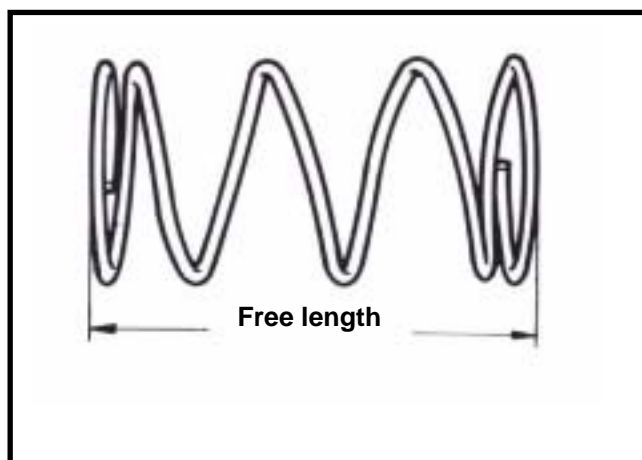

Driven pulley

Check following items:

If both surfaces are damage or wear.

If guide pin groove is damage or wear.

Replace damaged or worn components.

Measure the outer diameter of driven surface and the inner diameter of driven pulley.

Replace it if exceeds service limit.

Service limit: Outer diameter 33.94 mm

Inner diameter 34.06 mm

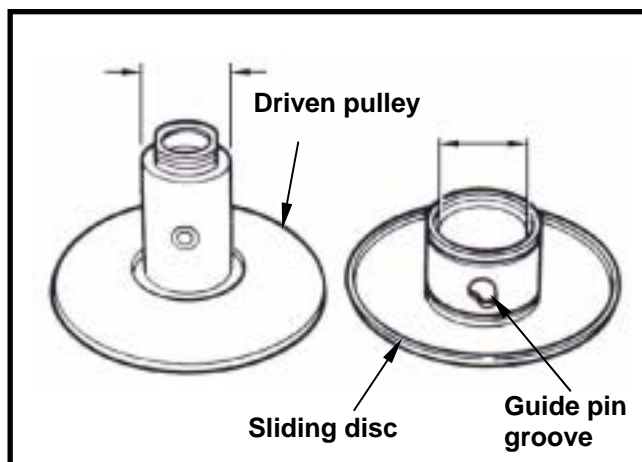

Driven Pulley Bearing Inspection

Check if the inner bearing oil seal is damage. Replace it if necessary.

Check if needle bearing is damage or too big clearance. Replace it if necessary.

Rotate the inside of inner bearing with fingers to check if the bearing rotation is in smooth and silent. Also check if bearing outer is installed properly. Replace it if necessary.

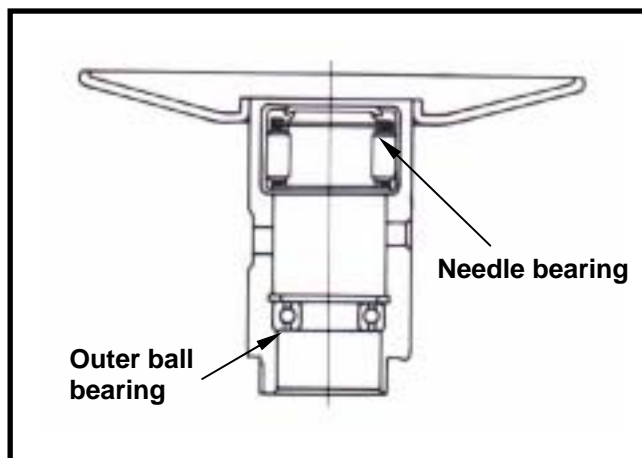



8. V-Belt Driving System/Foot Starter

Clutch Block Replacement

Remove snap and washer, and the remove clutch block and spring from driving plate. Check if spring is damage or insufficient elasticity.

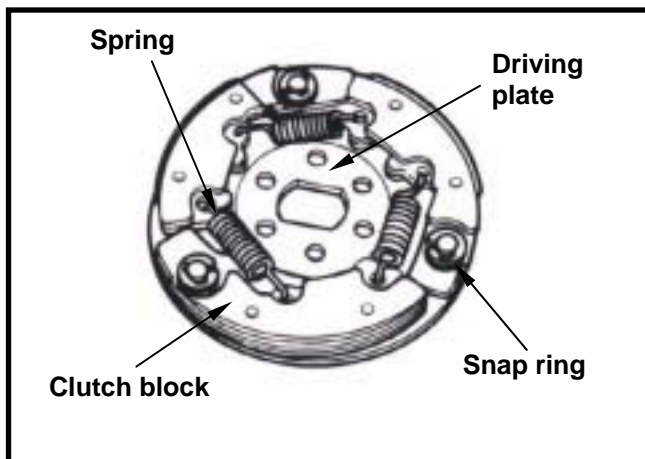

Check if shock absorption rubber is damage or deformation. Replace it if necessary. Apply with grease onto setting pins.

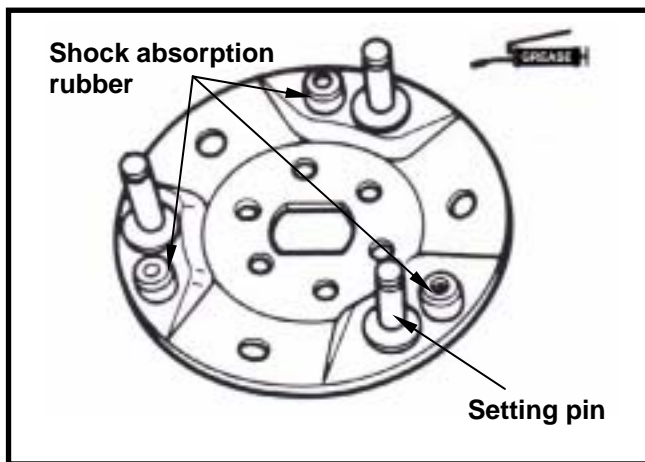

Apply with grease onto setting pins. But, the clutch block should not be greased. If so, replace it. Install new clutch block onto setting pin and then push to specified location.

⚠ Caution

- Grease or lubricant will damage the clutch block and effect the block's connection capacity.

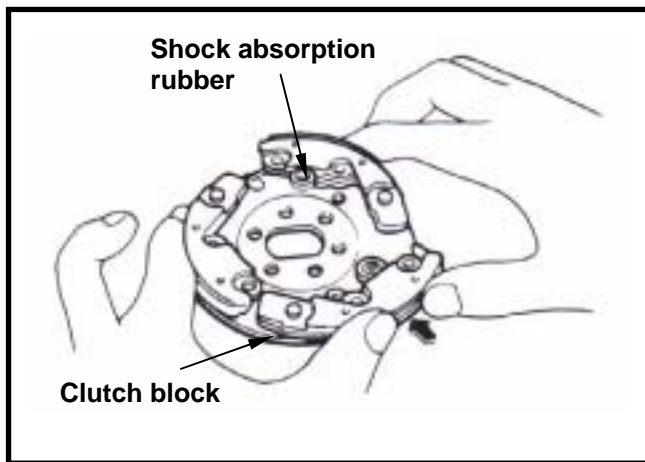

Install the spring snap into groove with pliers.



8. V-Belt Driving System/Foot Starter

Install snap ring and mounting plate onto setting pin.

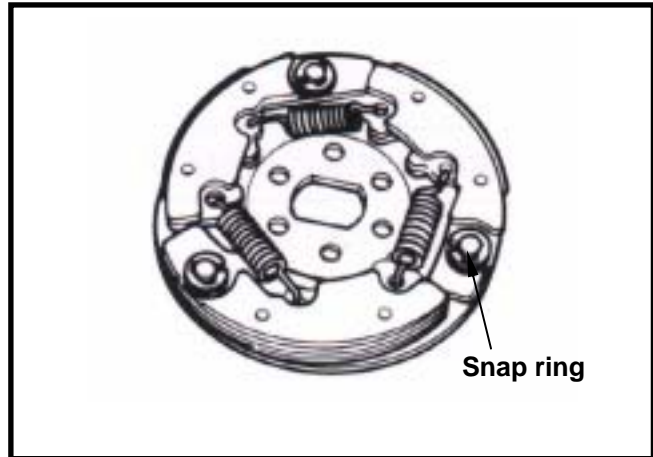

REPLACEMENT OF DRIVEN PULLEY BEARING

Remove inner bearing.

⚠ Caution

- If the inner bearing equipped with oil seal on one side in the driven pulley, then remove the oil seal firstly.
- If the pulley equipped with ball bearing, it has to remove snap ring and then the bearing.

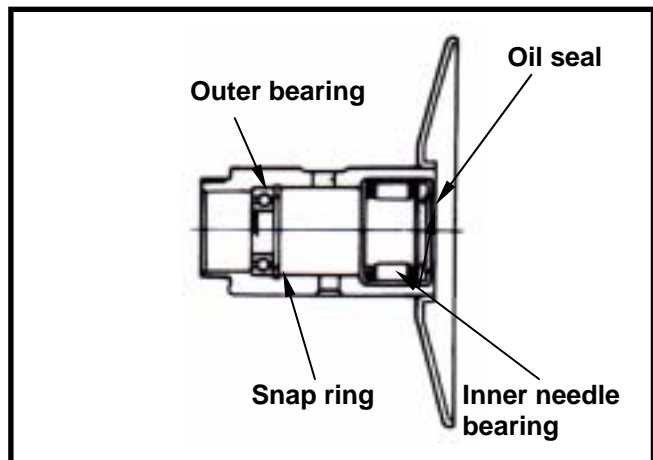

Remove snap ring and then push bearing forward to other side of inner bearing. Place new bearing onto proper position and its sealing end should be forwarded to outside. Apply with specified grease. Recommended to use the KING MATE G-3. Install the snap ring and hold the bearing.

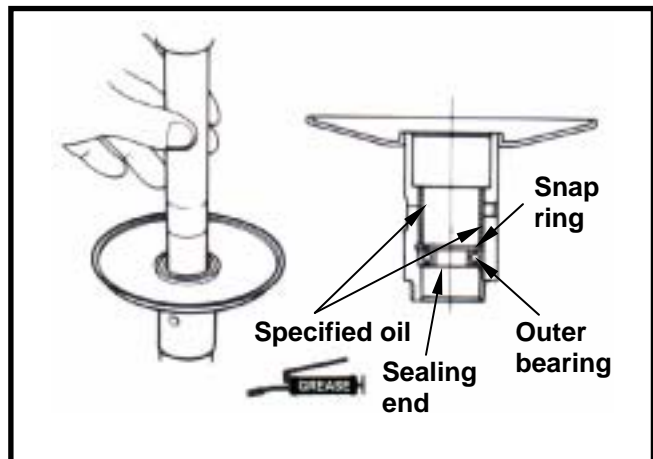

Install a new inner bearing.

⚠ Caution

- Its sealing end should be forwarded to outside as bearing installation.
- Install needle bearing with hydraulic presser. Install ball bearing by means of hydraulic presser.

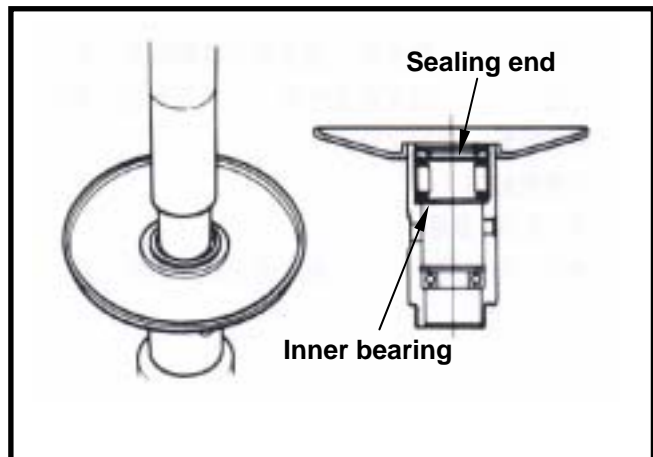

Align oil seal lip with bearing, and then install the new oil seal. (if necessary)

INSTALLATION OF CLUTCH/DRIVEN PULLEY ASSEMBLY

Install new oil seal and O-ring onto sliding pulley. Apply with specified grease to lubricate the inside of sliding pulley.

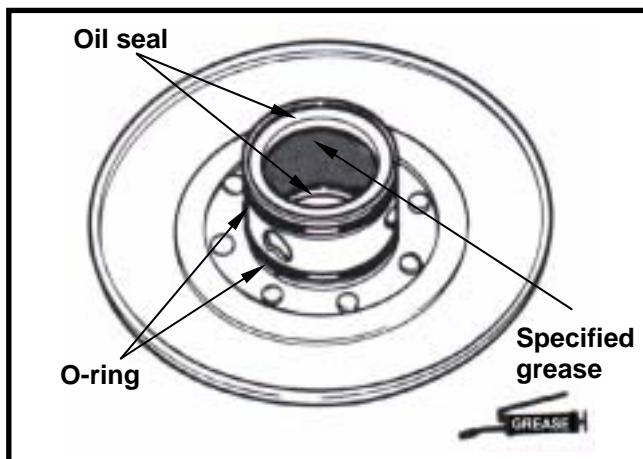

Install sliding pulley onto driven pulley. Install guide pin and guide pin roller.

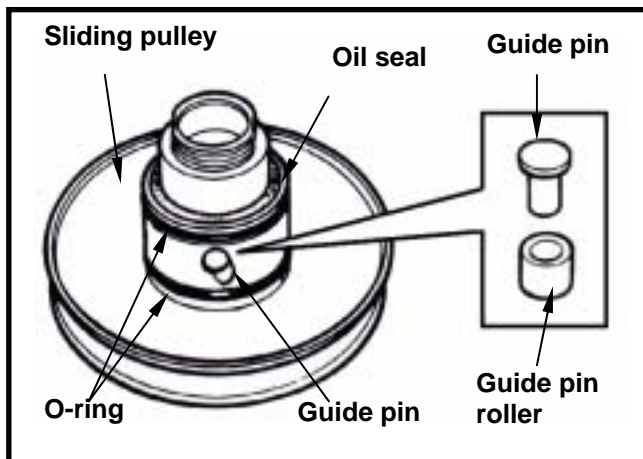

Install oil socket.

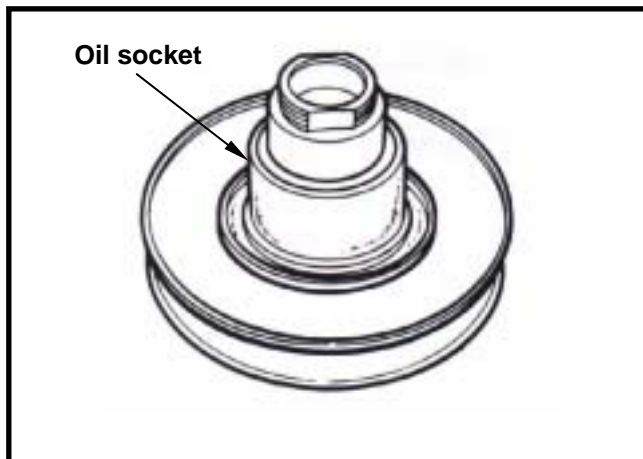

Install driving belt, spring and clutch into clutch spring compressor, and press down the assembly by turning manual lever until mounting nut that can be installed.

Hold the compressor by bench vise and tighten the mounting nut to specified torque with special nut wrench.

Remove the clutch spring compressor.

Torque value: 5.0~6.0 kgf-m

Install clutch/driven pulley and driving belt onto driving shaft.

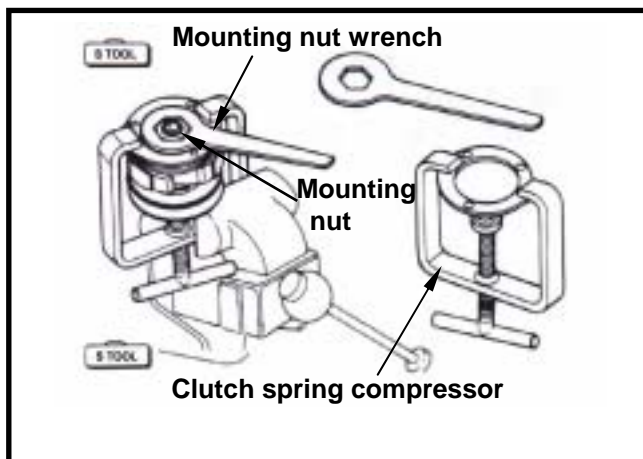

NOTES:

9. Final Driving Mechanism

Mechanism Illustration 9-1	Inspection Of Final Driving Mechanism.....9-3
Operational precautions..... 9-2	Bearing Replacement.....9-4
Trouble Diagnosis.....9-2	Re-Assembly Of Final Driving Mechanism9-6
Disassembly of Final Driving Mechanism 9-3	

Mechanism Illustration

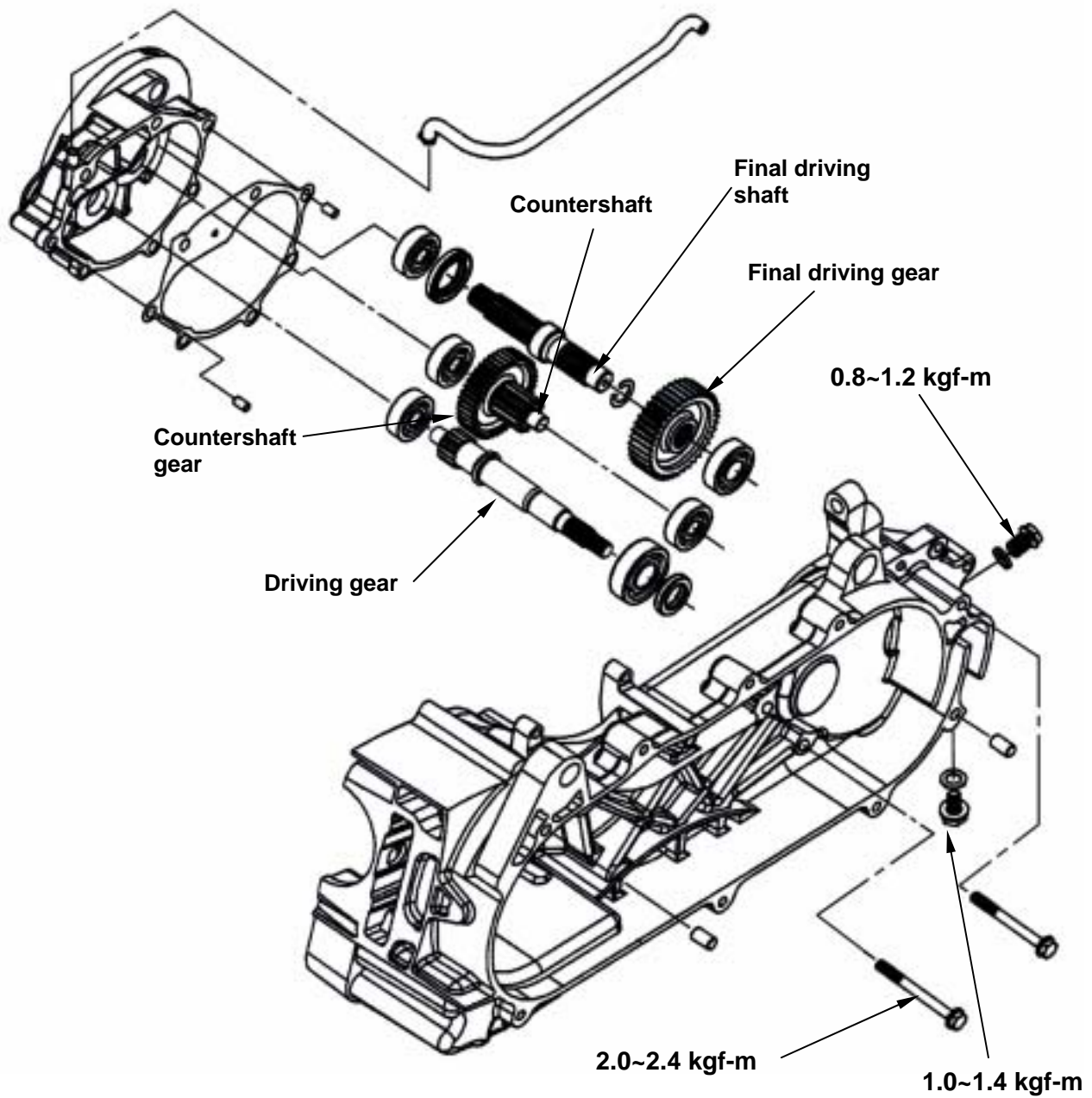

9. Final Driving Mechanism

Operational precautions

Specification

Application gear oil: 4-stroke lubricant
 Recommended oil: KING MATE serial gear oils
 Oil quantity: 110 c.c. (100 c.c. when replacing)

Torque value

Gear box cover	2.0~2.4 kgf-m
Gear oil drain plug	1.0~1.4 kgf-m
Gear oil filling bolt	0.8~1.2 kgf-m

Tools

Special service tools

Inner type bearing puller
 Outer type bearing puller
 Gear box oil seal installer
 Gear box bearing installer

Trouble Diagnosis

Engine can be started but motorcycle can not be moved

- Damaged driving gear
- Burnt out driving gear
- Broken driving belt

Gear oil leaks

- Excessive gear oil
- Worn or damage oil seal

Noise

- Worn or burnt gear
- Worn gear



9. Final Driving Mechanism

Disassembly of Final Driving Mechanism

Remove the rear wheel. (refer to chapter 15)
 Remove the clutch.
 Drain gear oil out from gear box.
 Remove gear box cover bolts (7 bolts) and then remove the cover and the final driving shaft.
 Remove gasket and setting pin.

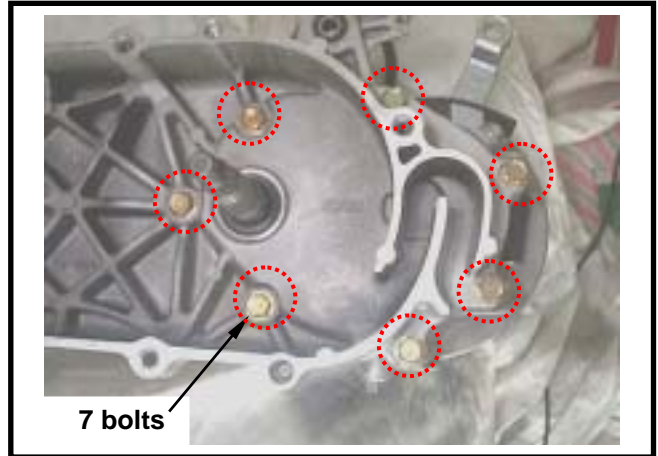

Remove countershaft and gear.
 Remove final driving gear and shaft.

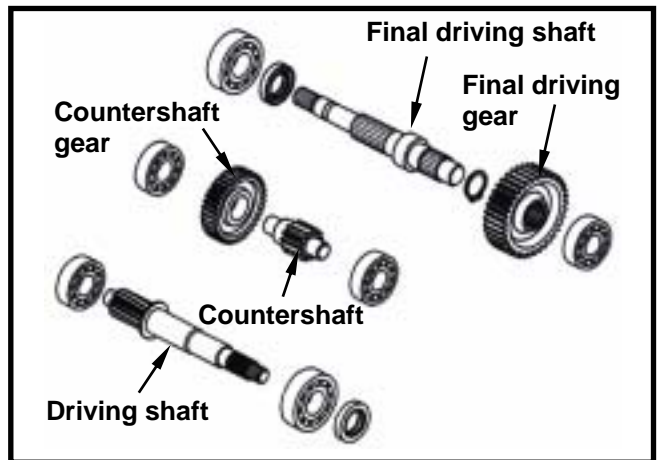

Inspection Of Final Driving Mechanism

Check if the countershaft and the gear are wear out or damage.

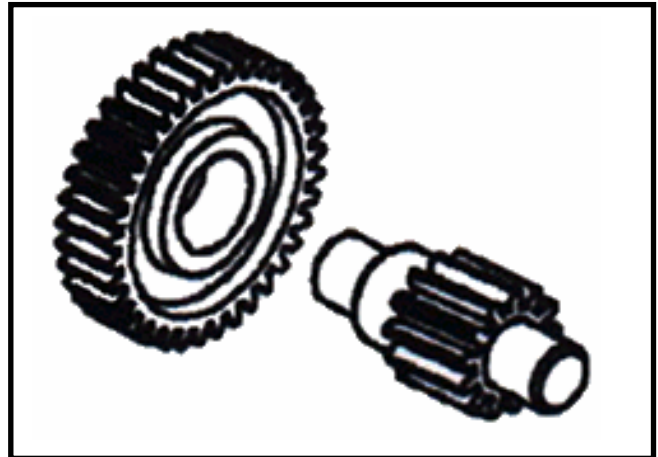

Check if the final driving shaft and gear are burn, wear or damage.

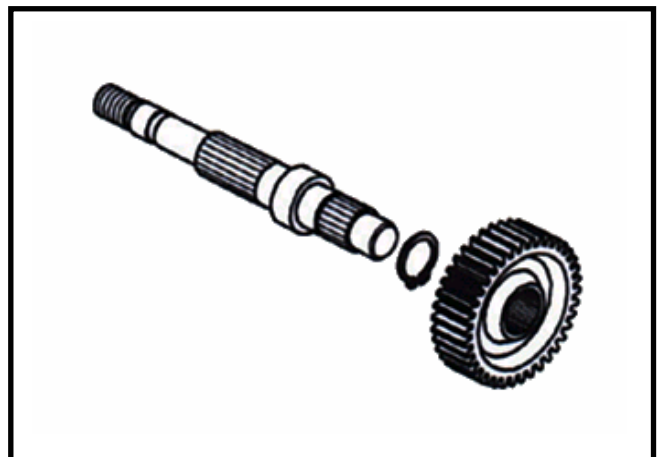

9. Final Driving Mechanism

Check bearings on gear box and cover.
 Rotate each bearing's inner ring with fingers.
 Check if bearings can be turned in smooth and silent, and also check if bearing outer ring is mounted on gear box & cover tightly.
 If bearing rotation is uneven, noising, or loose bearing mounted, then replace it.
 Check oil seal for wear or damage, and replace it if necessary.

Caution

Do not remove the driving shaft from the cover top side.
 If remove the driving shaft from the gear box, then its bearing has to be replaced.

Check driving shaft and gear for wear or damage.

Bearing Replacement

Caution

Never install used bearings. Once bearing removed, it has to be replaced with new one.

Remove driving shaft bearing from left crankcase using following tools:
 Inner type bearing puller

Install new driving shaft bearing into left crankcase.

Special tool:

Press the bearing into cover with C type hydraulic presser or bearing installer.





9. Final Driving Mechanism

Press out the driving shaft from the gear box.
 Remove oil seal from the gear box.
 Remove the driving shaft bearing from the gear box cover with the inner type bearing puller.

⚠ Caution

Using the bearing protector as pressing out the driving shaft from the gear box cover.

Specified tool:

Inner type bearing puller.



If the driving shaft is pulled out with its bearing, then remove the bearing with bearing puller and bearing protector.

Special tool:

Multi-functional bearing puller

Bearing protector

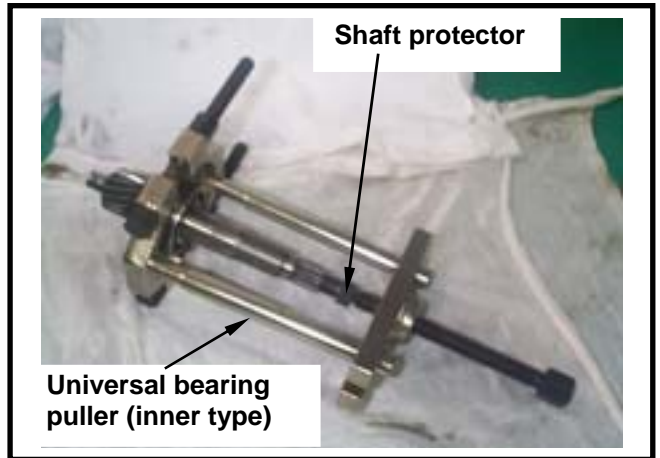

Install a new driving shaft bearing onto gear box cover.

Then, install the driving shaft.

Specified tool:

Press the bearing in with C type hydraulic presser or bearing installer.



Install a new final driving shaft bearing onto gear box cover.

Specified tool:

Press the bearing in with C type hydraulic presser or the bearing installer.

Apply with some grease onto the lip section of oil seal and then install the seal.



9. Final Driving Mechanism

Re-Assembly Of Final Driving Mechanism

Install final driving shaft and final driving gear, countershaft, and countershaft gear.

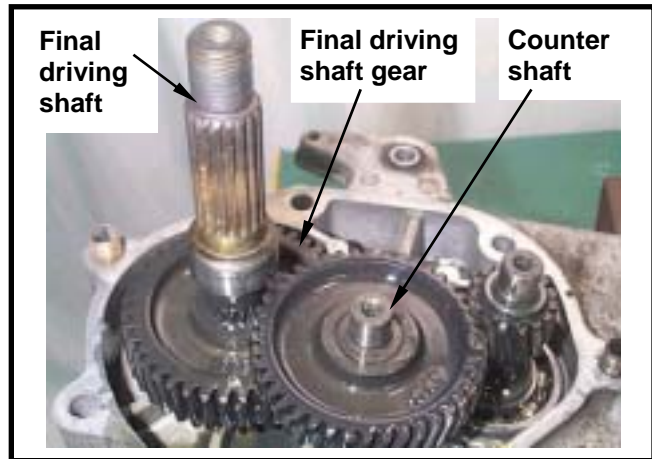

Install the setting pins (2 pins) and new gasket.



Apply with grease onto the oil seal lip of final driving shaft.
Install the gear box cover and 7 bolts. (tighten the bolts)

Torque: 2.0~2.4 kgf-m

Install the clutch/sliding driving pulley.
Install the driving pulley, belt and left crankshaft cover.

Install the rear wheel.

Add gear oil.

Recommended usage: SYM HYPOID GEAR OIL (SAE 85W-140)

(110 cc: standard capacity)

(100 cc: when replacement)

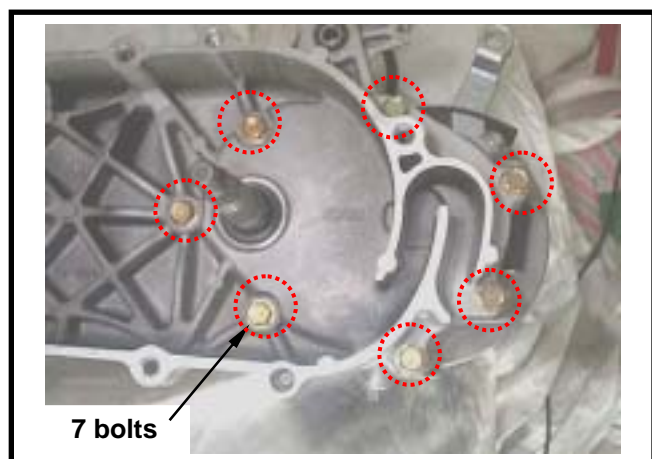

Mechanism Illustration	1	Starting Clutch	10-5
Precautions in Operation	10-2	Right Crankcase Cover Installation	10-8
Alternator Removal.....	10-3	Mounted Coil Set Installation .	10-8
Alternator Coil Set Removal ...	10-4	Flywheel Installation	10-8
Right Crankcase Cover Removal	10-4		

Mechanism Illustration

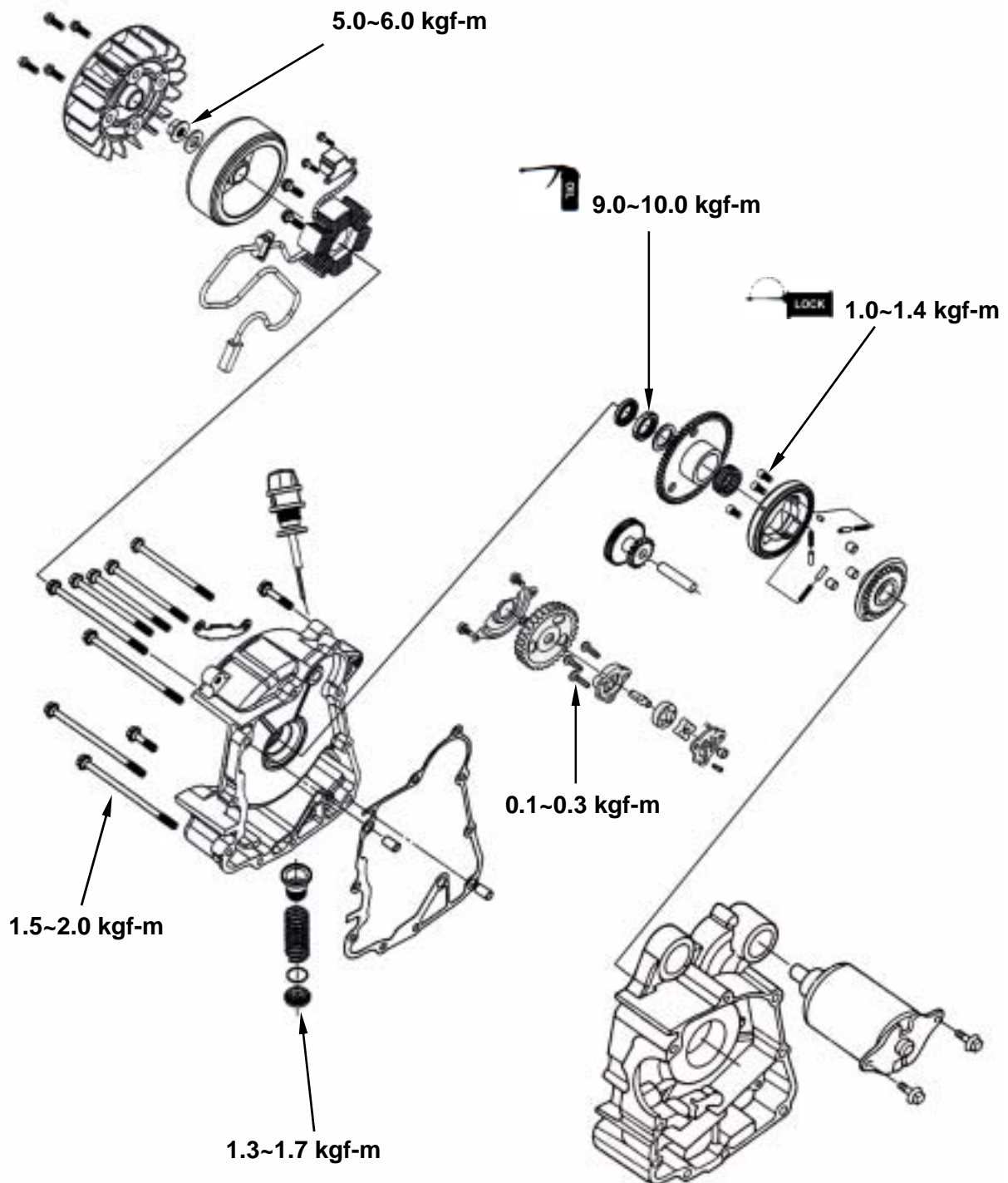

10. Alternator/Starting Clutch

Precautions in Operation

General information

- Refer to chapter 5: Engine removal and installation
- Refer to chapter 1: The troubleshooting and inspection of alternator
- Refer to chapter 16: The service procedures and precaution items of starter motor

Specification

Unit: mm

Item	Service Limit
ID of starting driven gear	32.060
OD of clutch cover	27.940

Torque value:

Flywheel nut	5.0~6.0 kgf-m
Bolt 8mm	1.5~2.0 kgf-m
Oil screen cover	1.3~1.7 kgf-m
Starting clutch mounting bolt	9.0~10.0 kgf-m with oil on the thread
Starting clutch hex socket bolt	1.0~1.4 kgf-m with adhesive

Special service tools

Flywheel puller
 Universal fixture

Alternator Removal

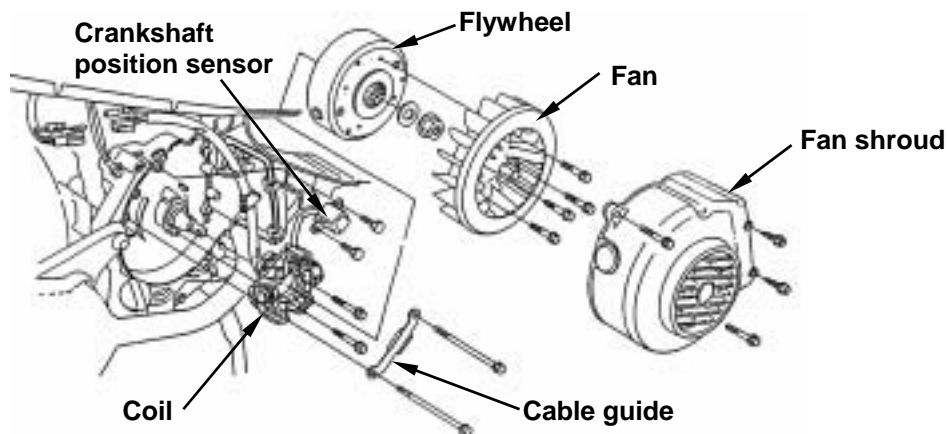

Drain out the engine oil.
 Remove the right side cover. (4 screws)
 Remove the exhaust pipe. (2 bolts, 2 nuts)
 Remove the fan shroud. (2 screws)
 Remove the cooling fan shroud. (bolt x 2, screw x 2)



Remove the cooling fan. (4 bolts)

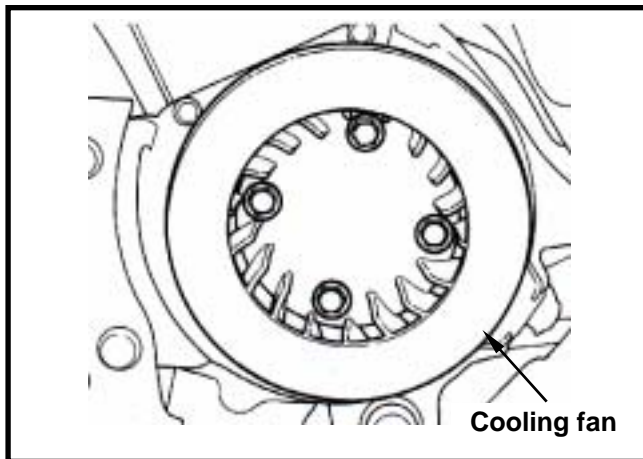

Hold the flywheel with the universal fixture.
 Remove the 10mm nut on the flywheel.

Special Service Tools:
Universal Fixture

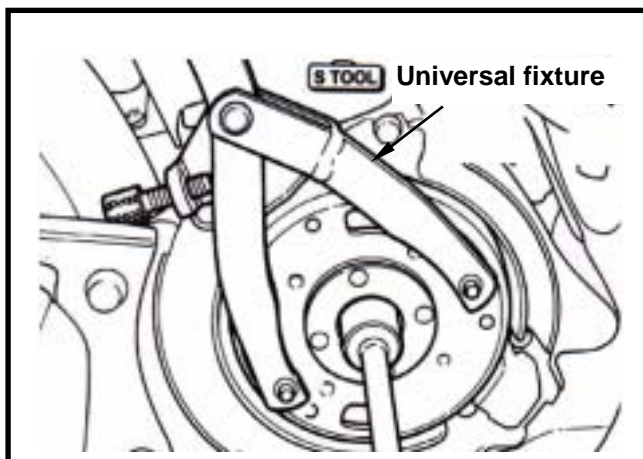

10. Alternator/Starting Clutch

Remove the flywheel with the flywheel puller.

Special service tools:

Flywheel puller

shaft protector

Caution

Install a shaft protector on the right end of crankshaft to avoid damaging the crankshaft before installing the flywheel puller.

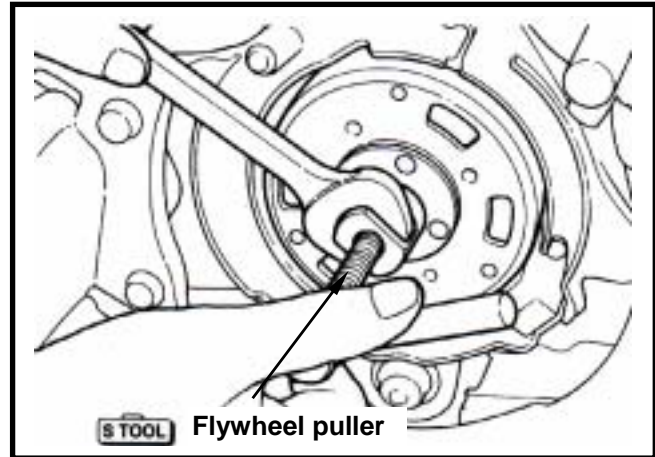

Alternator Coil Set Removal

Remove the connectors of the alternator and crankshaft position sensor.

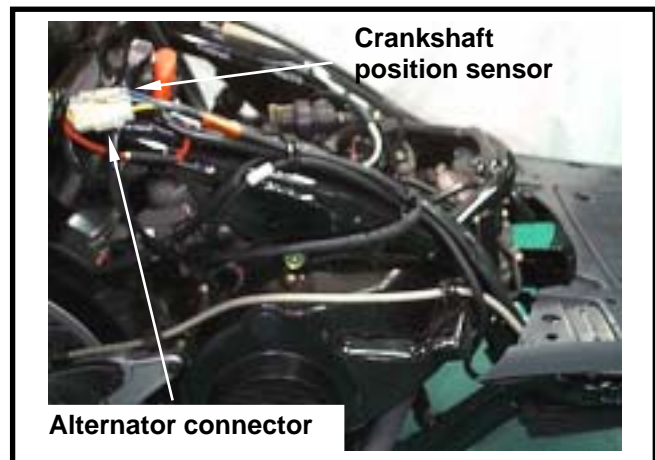

Remove the 6 bolts for the crankshaft position sensor, the alternator coil and cable guide. Then, remove the alternator assembly.

Caution

Do not damage the alternator coil.

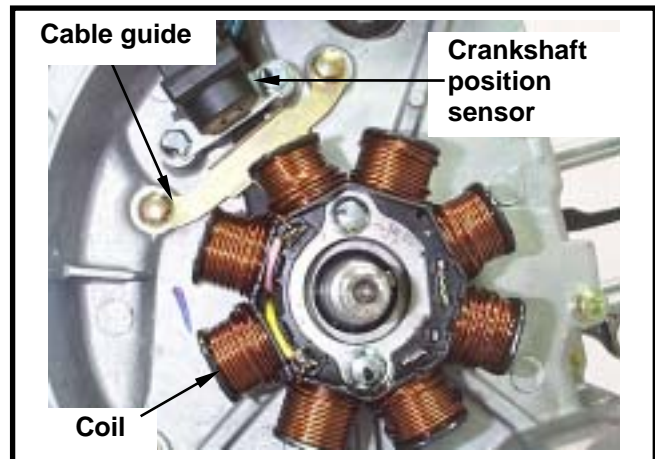

Right Crankcase Cover Removal

Remove the right crankcase cover. (8 bolts)

Remove setting pin and gasket.

Remove the gasket or foreign materials on the connection surfaces of both the cover and crankcase.

Caution

Do not damage the connection surfaces.

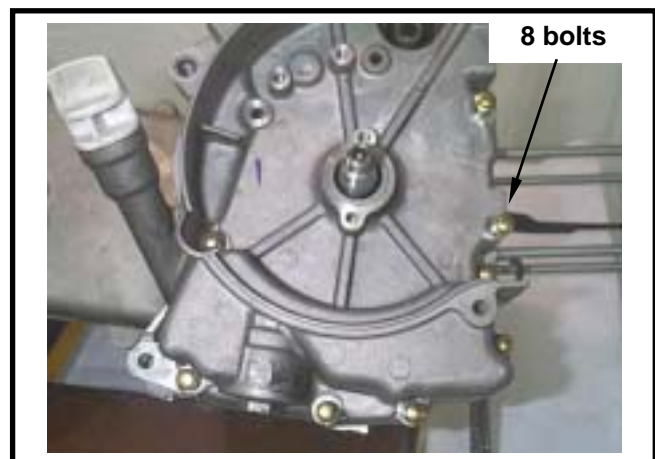



10. Alternator/Starting Clutch

Starting Clutch

Starting Clutch Removal

Hold the starting driven gear with the universal fixture.

Remove the 22mm anti-loosen mounting nut and gasket.

Special service tools:

Anti-loosen mounting nut socket

Universal fixture

 **Caution**

The mounting nut is left-turn thread.

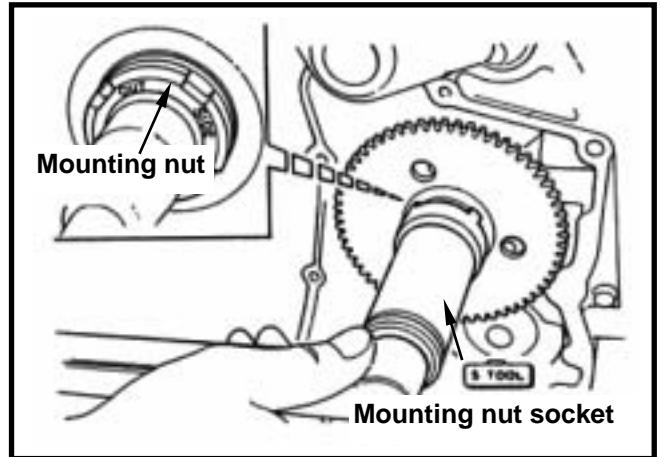

Remove the starting driven gear.



Remove starting clutch, starting idle-gear, and shaft.



Starting Clutch Inspection

Install the starting clutch onto the starting driven gear.

Hold the starting clutch and turn the starting driven gear.

The starting driven gear should can be turned in the motion of C.W. and can not be turned in C.C.W.

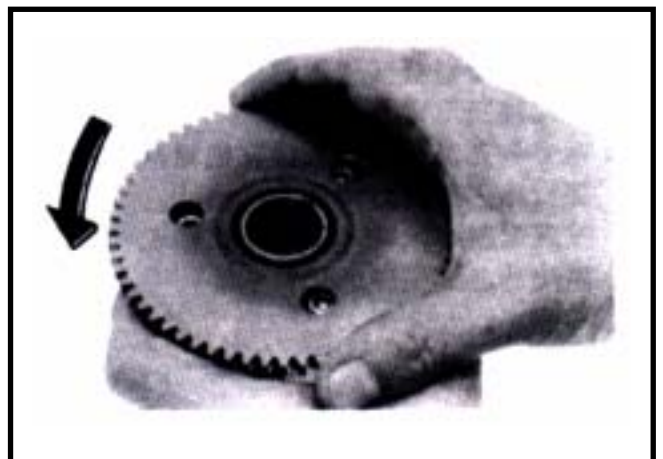

10. Alternator/Starting Clutch

Check the starting driven gear for wear or damage.

Measure the ID of the starting driven gear.

Service Limit:

ID: 32.06 mm or less



Check the starting idle gear and shaft for wear or damage.

Measure the ID of the starting idle gear.

Service Limit:

ID: 10.05 mm or less

Measure the OD of the starting idle gear.

Service Limit:

OD: 9.94 mm or more

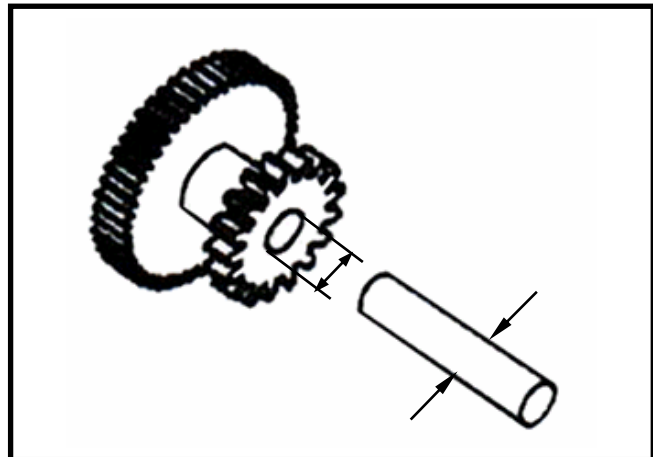

Disassembly

Remove the hex bolts (3 bolts) inside the starting clutch.

Separate the clutch body and the clutch cover.

Remove the rollers, plugs, and springs on the one way clutch.

Check each rollers and plugs for wear or damage.

Install rollers, plugs and springs.

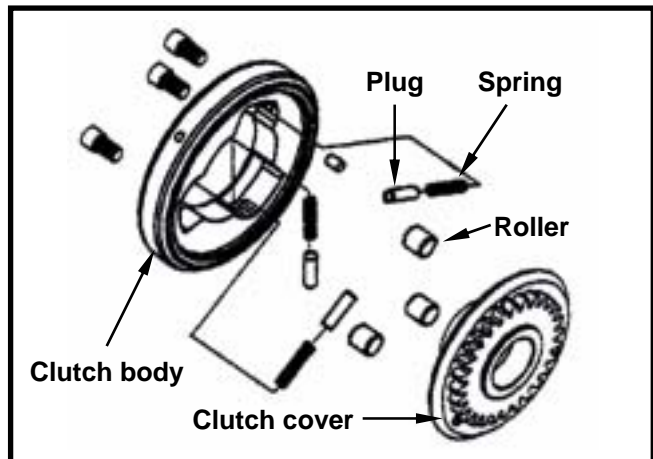

Measure the OD of the starting clutch cover.

Service Limit:

OD: 27.94 mm or more

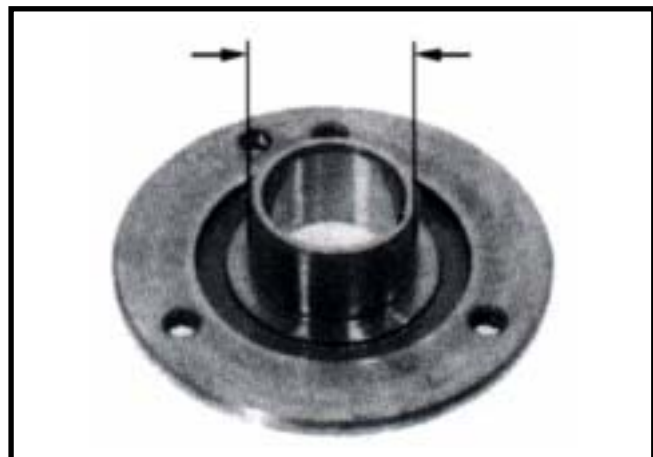



10. Alternator/Starting Clutch

Installation

Install the components in the reverse procedures of removal.

⚠ Caution

Add adhesive onto the thread of hex socket bolt.

Torque value: 1.0~1.4 kgf-m

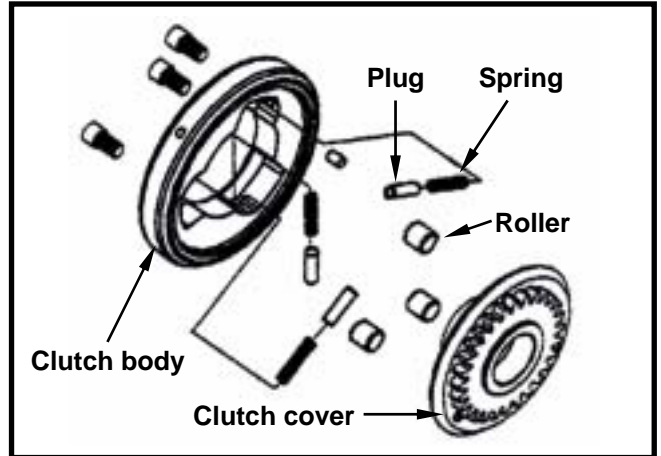

Starting clutch Installation

Install idle gear shaft and idle gear.
Install starting clutch.



Install the starting driven gear onto the starting clutch.



Hold the starting driven gear with the universal fixture.
Tighten the 22mm anti-loosen mounting nut and gasket.

⚠ Caution

Add engine oil onto the thread of mounting nut.

Special service tools:
Anti-loosen mounting nut socket
Universal fixture.
Torque value: 9.0~10.0 kgf-m

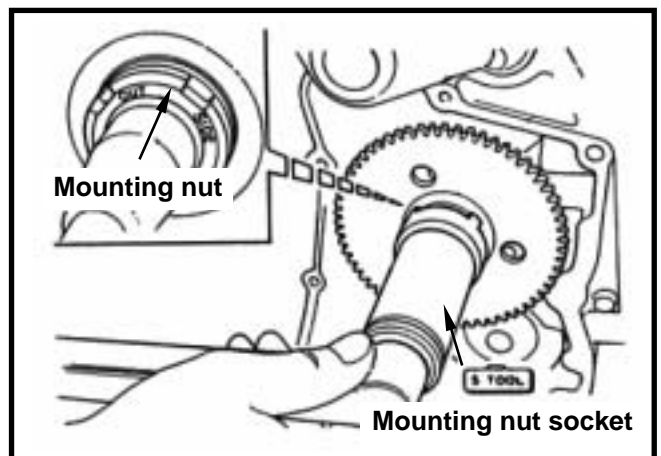

10. Alternator/Starting Clutch

Right Crankcase Cover Installation

Install setting pin and new gasket on the crankcase.
 Replace the right crankshaft oil seal of the crankcase and apply some oil onto the oil seal lip.
 Install right crankcase cover onto the right crankcase. (8 bolts)
Torque value: 1.5~2.0 kgf-m

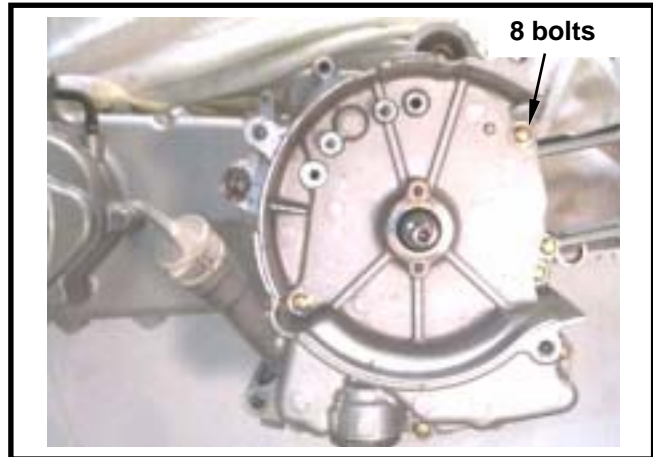

Mounted Coil Set Installation

Install the coil set onto right crankcase cover. (2 screws)
 Install crankshaft position sensor. (2 screws)
 Tighten the cable guide. (2 screws)
Torque: 1.5~2.0 kgf-m
 Tie the wire harness hose onto the indent of crankcase.

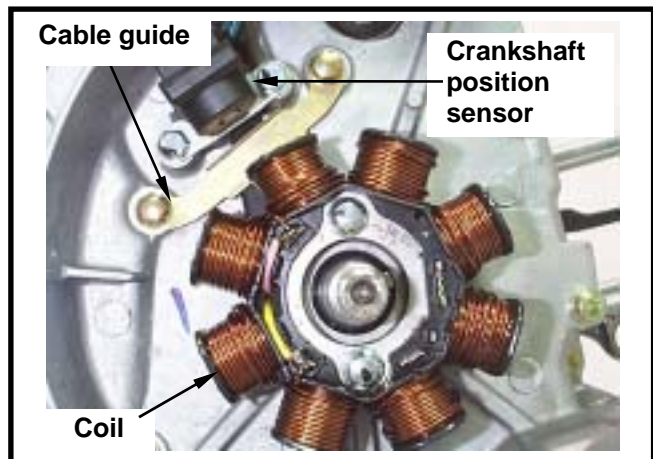

⚠ Caution

Make sure that the wire harness is placed under the crankshaft position sensor.

Connect the connectors of alternator and crankshaft position sensor.

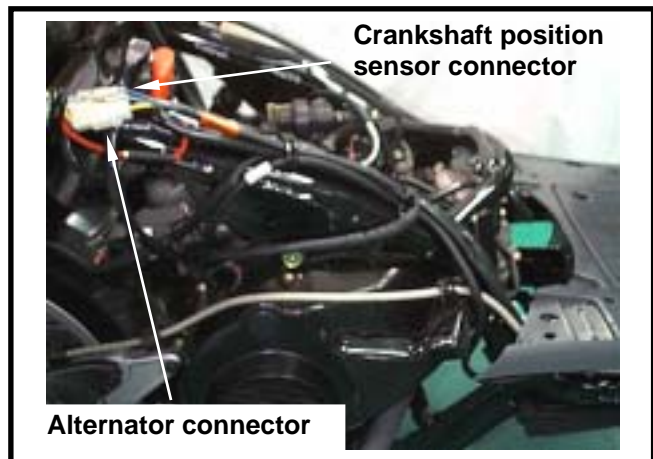

Flywheel Installation

Make sure that there is no magnetic powder. If so, clean up it.
 Align insert on crankshaft with the flywheel groove, and then install the flywheel.
 Hold the flywheel with flywheel holder, and tighten its nut.
Torque value: 5.0~6.0 kgf-m
Special service tool:
Universal fixture

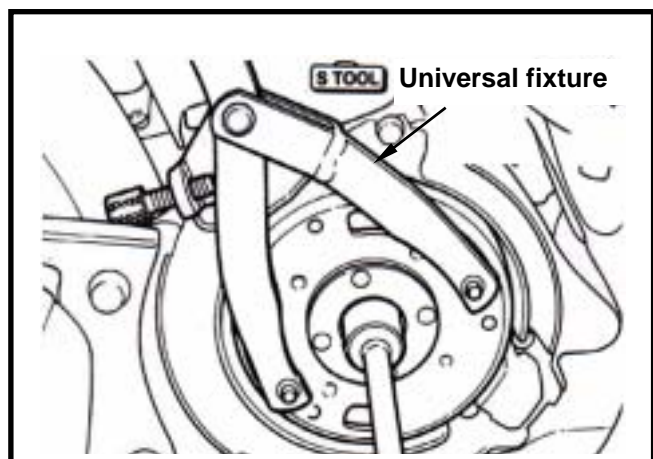

Install the cooling fan. (4 bolts)

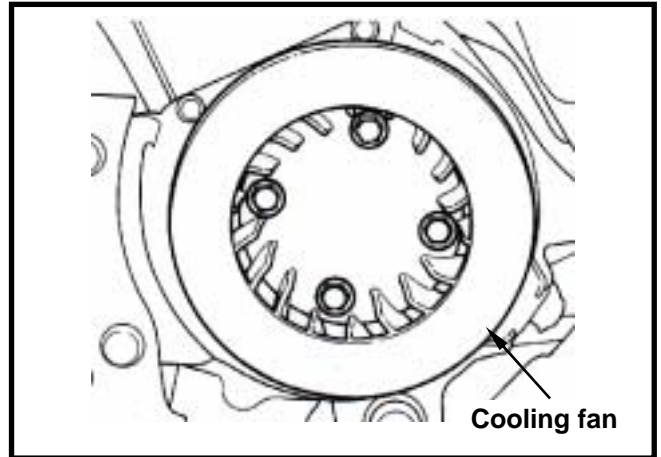

Install the cooling fan shroud. (3 screws)
Install the rear bracket mounting bolts. (2 bolts)
Install the exhaust pipe. (2 bolts, 2 nuts)
Install the right side cover. (4 screws)
Add some engine oil according to specified quantity.



10. Alternator/Starting Clutch

NOTES:

Mechanism Illustration11-1	Disassembly Of Crankcase 11-3
Operational precautions.....11-2	Crankshaft Inspection..... 11-4
Trouble diagnosis11-2	Assembly Of Crankcase 11-5

Mechanism Illustration

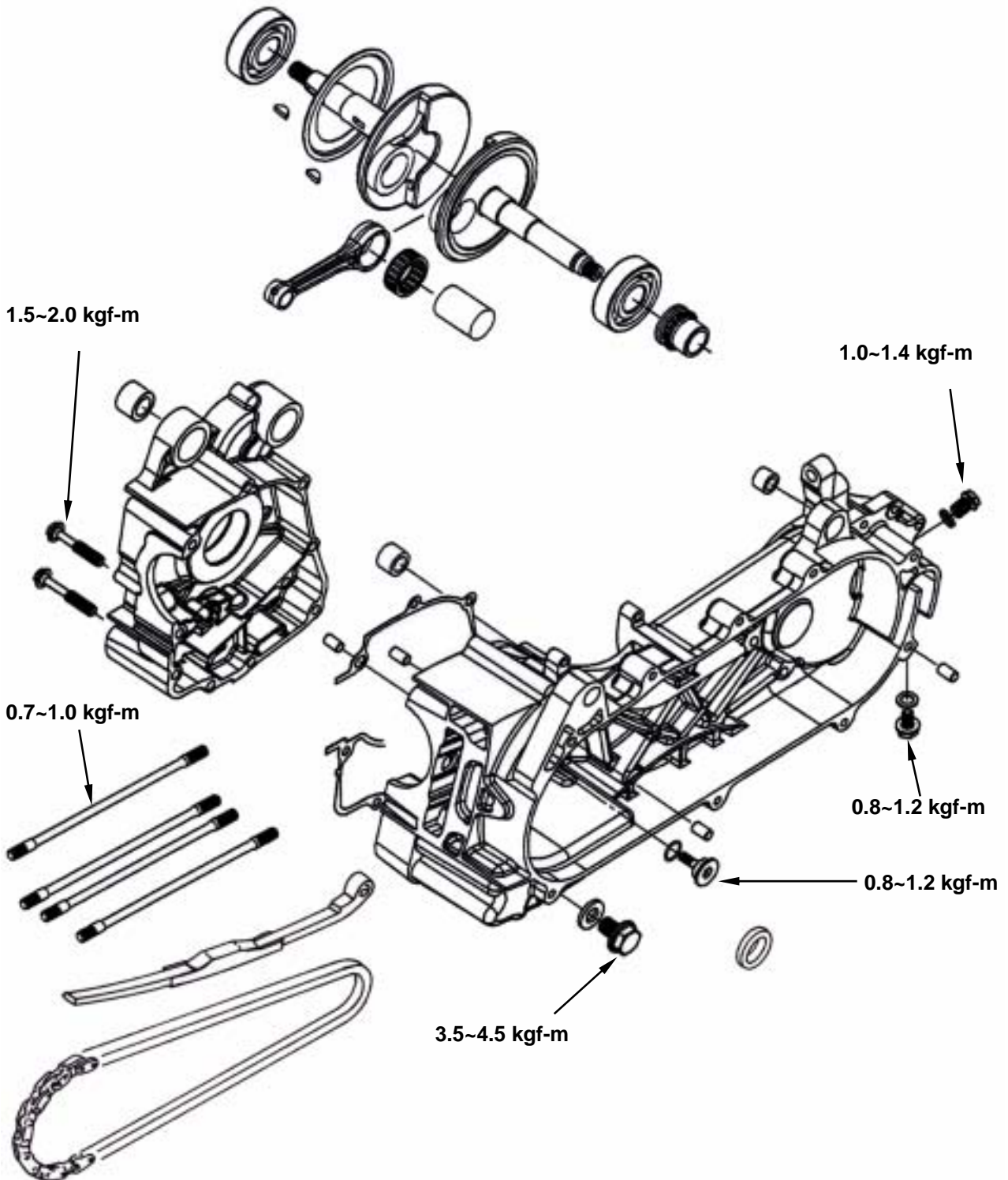



11. Crankcase/Crankshaft

Operational precautions

General Information

- This Section contains descriptions concerning disassembly of the crankcase so that the crankshaft can be serviced.
- Complete following operations before disassembling crankcase.

Engine	Chapter 5
Cylinder head	Chapter 6
Cylinder/ piston	Chapter 7
V-belt Drive pulley	Chapter 8
Alternator/Foot Starting Clutch	Chapter 10
Start motor	Chapter 16
- If the crankshaft bearing or timing sprocket need be replaced, then the crankshaft set have to replaced.

Specification

Unit: mm

Item	Standard	Limit
Left, right clearance of the big end of the connecting rod	0.100~0.300	0.550
Right angle clearance of the big end of the connecting rod	0.000~0.008	0.050
Run-out		0.100

Torque value

- Bolts for crankcase : 1.5~2.0 kgf-m
- Bolts for cylinder/cylinder head : 0.7~1.0 kgf-m
- Engine oil draining plug : 3.5~4.5 kgf-m
- Bolts for cam chain tensioner : 0.8~1.2 kgf-m

Special Service Tools

- Crankcase remover/set
- Crankshaft installation puller
- Inner type bearing puller
- Outer type bearing puller
- Bearing pressing tools
- Oil seal pressing tools

Trouble diagnosis

Engine noise

- Loose crankshaft bearing
- Loose crankshaft pin bearing
- Wear piston pin or piston pin hole

Disassembly Of Crankcase

Remove the cam chain tensioner (hex socket bolt x 1) from the left crankcase side.

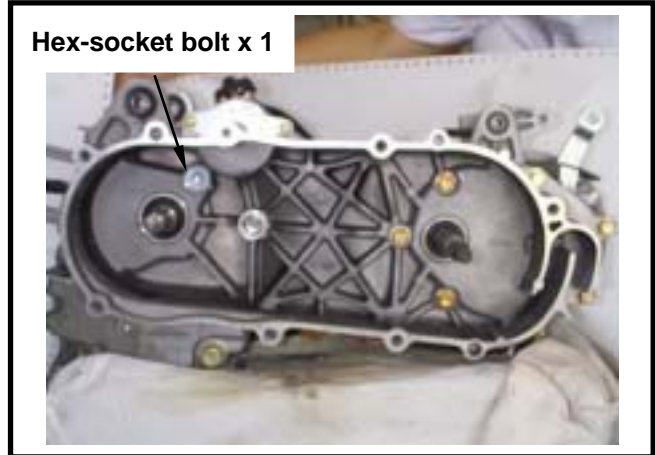

Remove the 2 bolts from the right side of crankcase, and then remove the right crankcase.

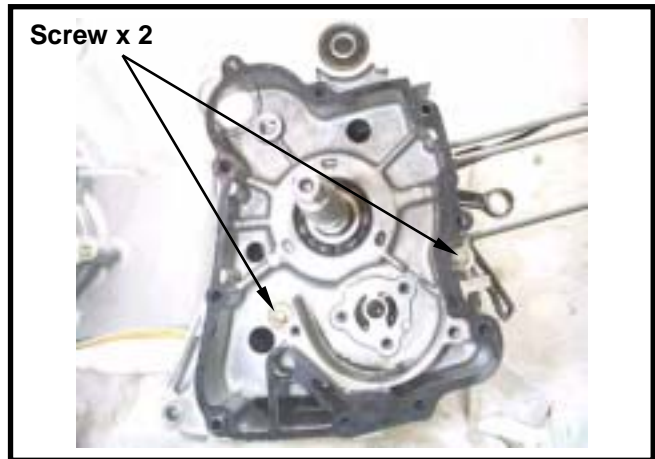

Remove the crankshaft from the left crankcase.
Remove the cam chain.
Remove the gasket and setting pin. (2 bolts)
Scrape gasket residues off the crankcase contact surface.

⚠ Caution

- Check if the right & left bearings are press-in the crankshaft.
- Do not damage contact surface of the crankcase.
- Soap the gasket residues into solvent and the residues will be removed easily.



Remove oil seal from the left crankcase side.

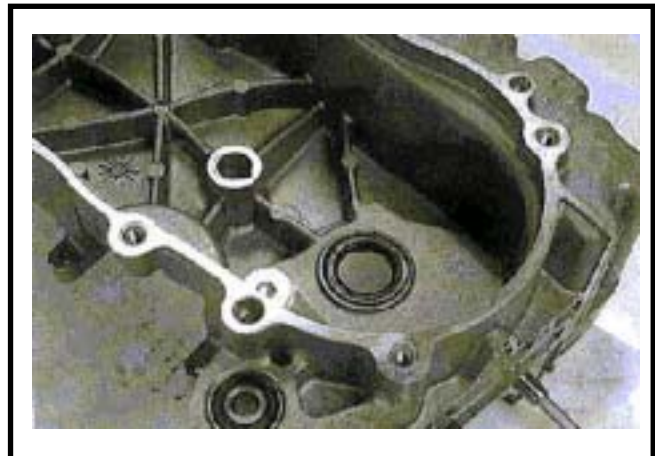

11. Crankcase/Crankshaft

Crankshaft Inspection

Measure left and right clearance of connecting rod big end.

Service limit: Replace when it is more than 0.55 mm

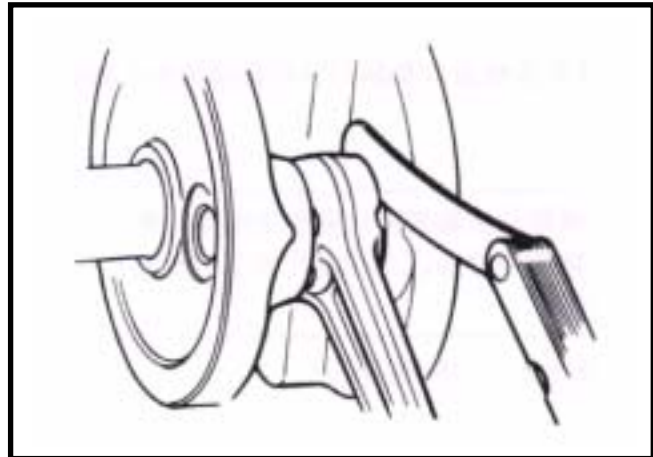

Measure the radical clearance of the big end at the vertical directions.

Service limit : 0.05 mm

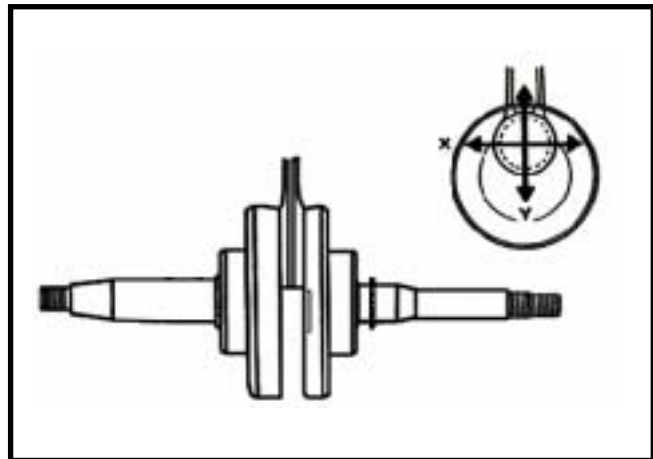

Place the crankshaft onto a V-block and measure run-out of the crankshaft with dial gauge.

Service limit: 0.10 mm

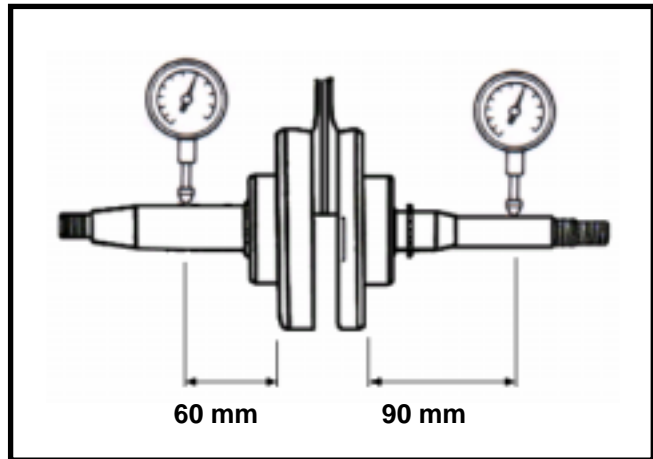

Bearing Inspection

Rotate the bearing with fingers and make sure the bearing can be rotated smoothly and quietly. Check if the inner ring is connected onto the crankshaft tightly.

Replace crankshaft as a set when noise or looseness is detected.

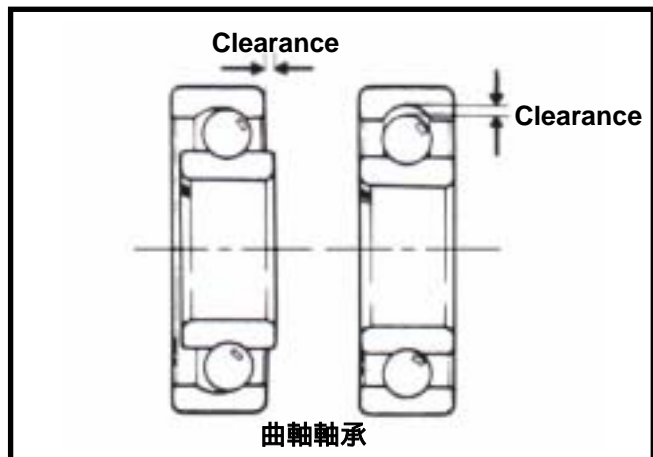



Assembly Of Crankcase

Install cam chain into the chain hole of the left crankcase, and then split out the cam chain.

⚠ Caution

Do not damage the cam chain as installing the crankshaft.

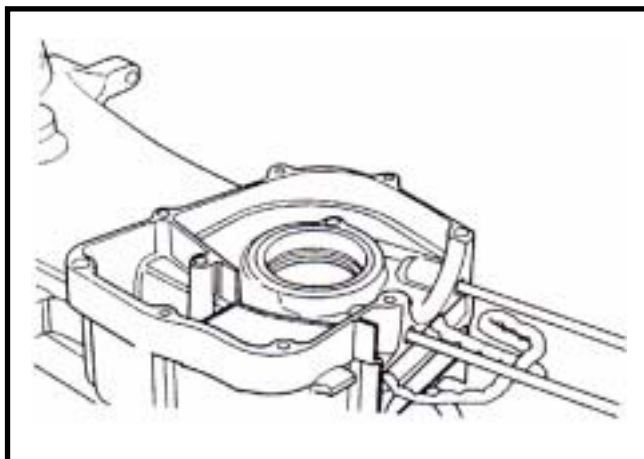

Install crankshaft into the left crankcase and then install two dowel pins and new crankcase gasket.

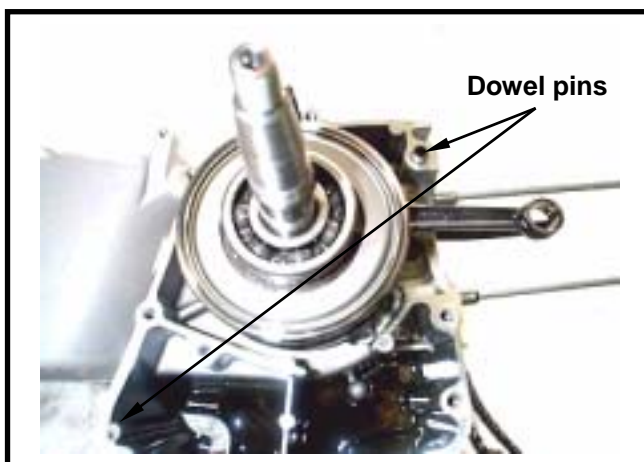

Install the right crankcase and tighten the crankcase bolts. (2 bolts)

Torque value: 1.5~2.0 kgf-m

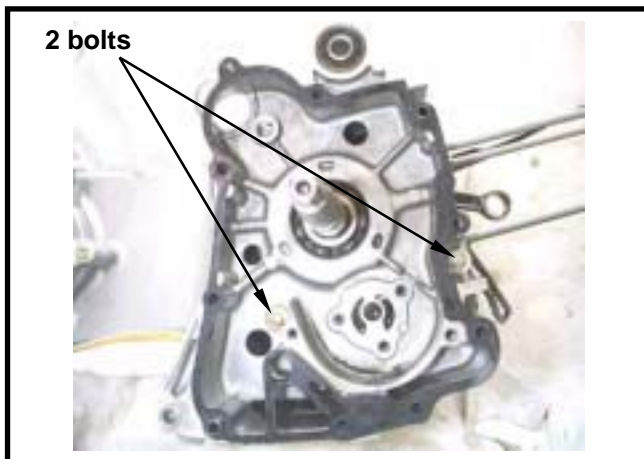

Install the cam chain tensioner. Install a new O-ring onto the mounting bolt of the chain tensioner.

Apply some oil on the O-ring and tighten the bolt. **Torque value: 0.8~1.2 kgf-m**

⚠ Caution

The O-ring must be installed into the bolt's groove.

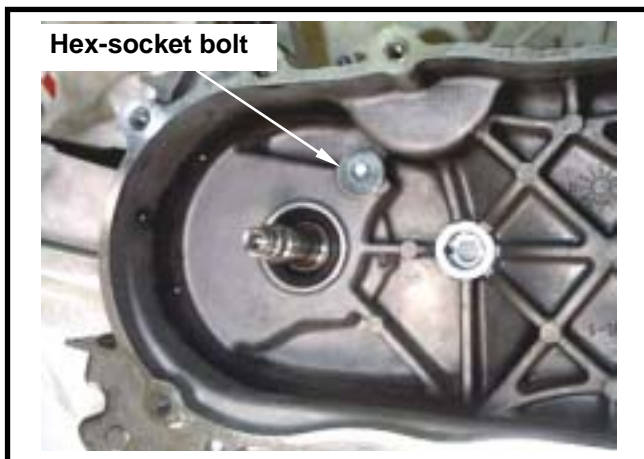

11. Crankcase/Crankshaft

Apply with some grease onto the oil seal lip and then install it onto the left crankcase.



Press-fit the oil seal to specified position with the oil seal installer (25x37x6).

Special service tools: the oil seal installer (25x37x6)



Mechanism Illustration	12-1	Luggage Box	12-8
Maintenance Information	12-2	Rear Carrier	12-9
Front Cover.....	12-3	Body Cover	12-10
Handlebar Cover	12-4	Left & Right Side-Foot Plates	12-11
Front Fender	12-5	Left & Right Side-Covers.....	12-11
Front Under Spoiler	12-6	Floor Panel.....	12-12
Inner Box	12-7	Rear Fender	12-13
Center Cover	12-8		

Mechanism Illustration

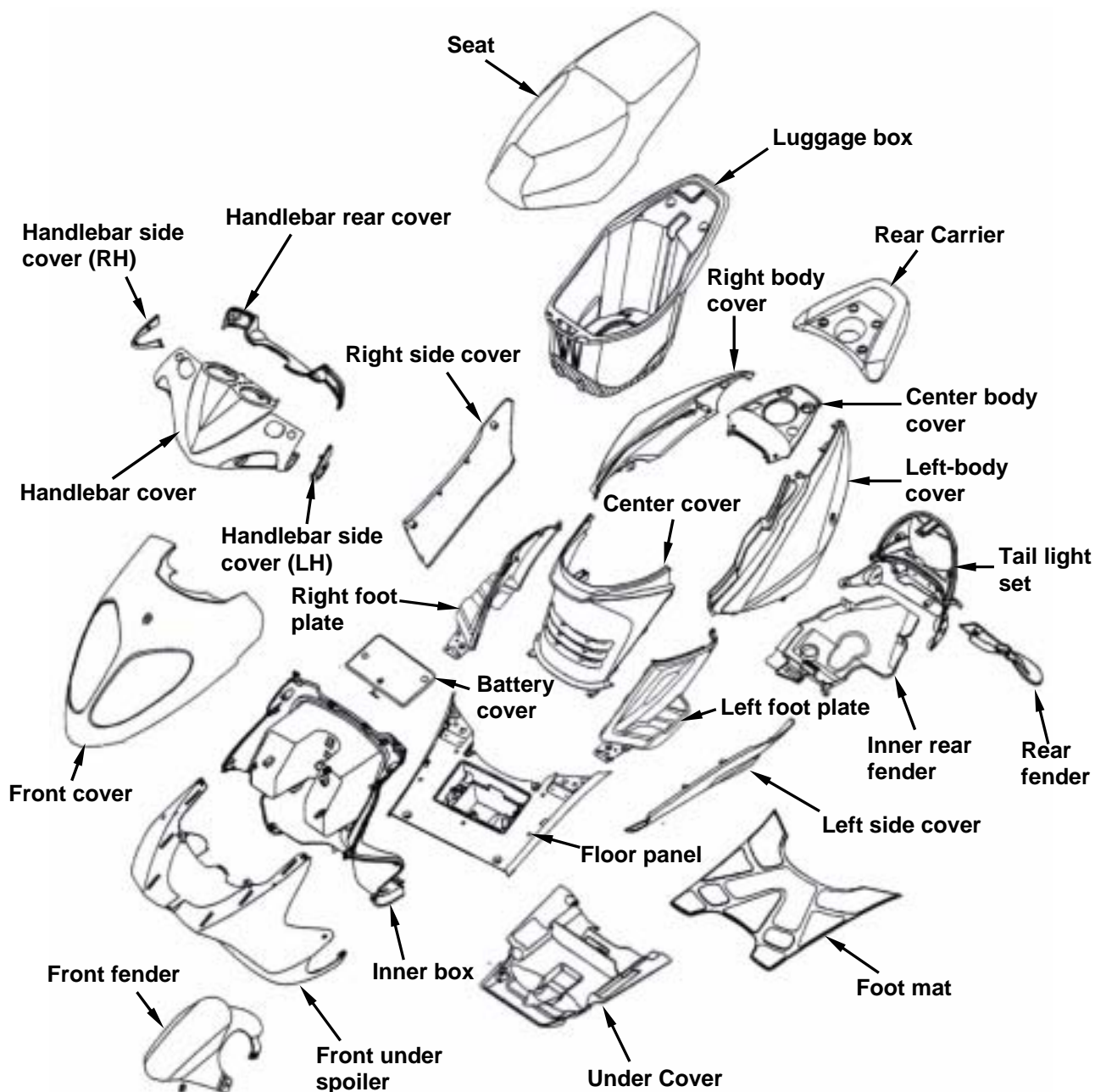

12. Body Cover

Maintenance Information

Body covers disassemble sequence:

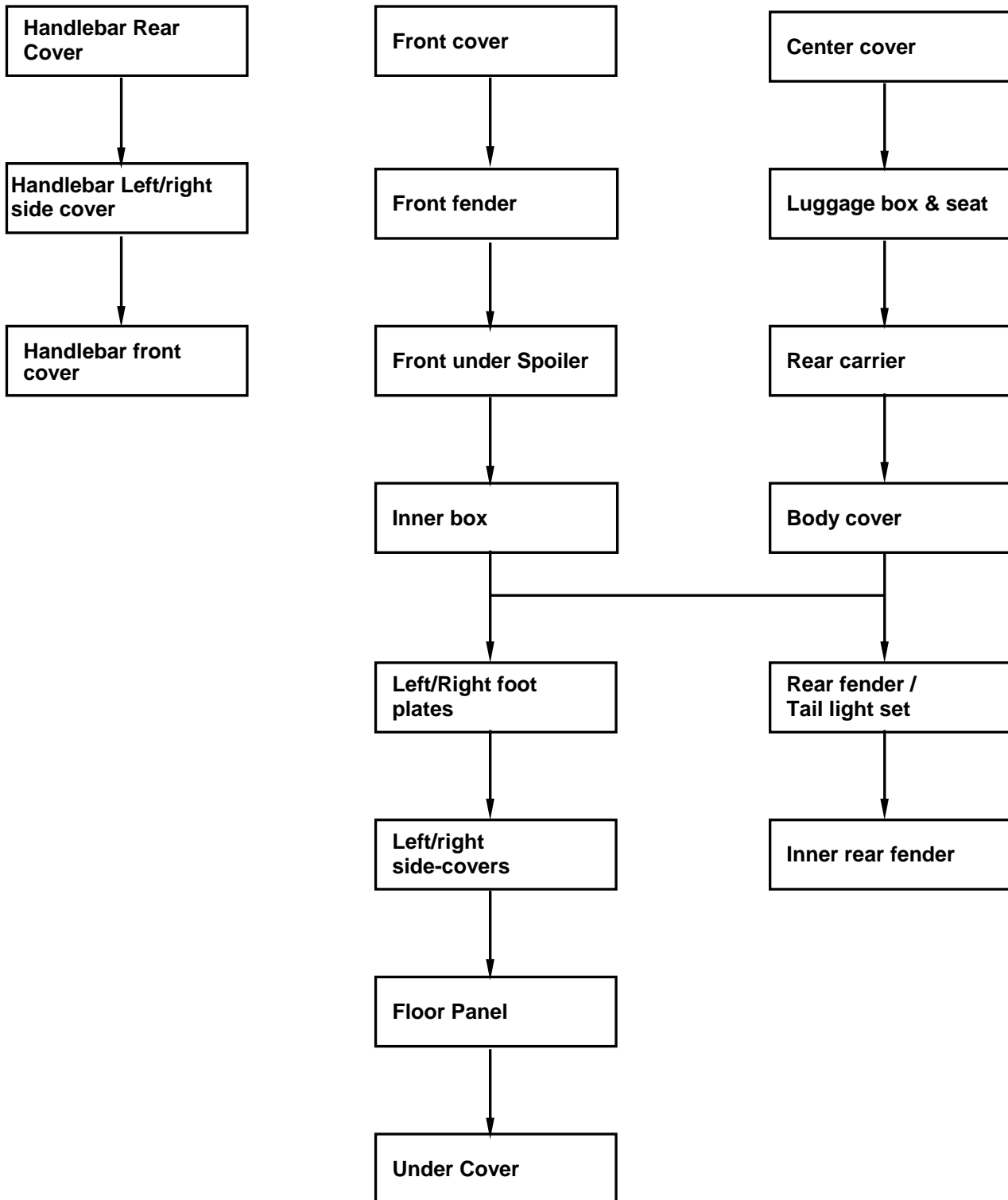

- Be careful not to damage various covers in disassembly or re-assembly operation.
- Never injure hooks molded on the body covers in disassembly or re-assembly operation.
- Align the buckles on the guards with slot on the covers.
- Make sure that each hook is properly installed during the assembly.
- Never compact forcefully or hammer the guard and the covers during assembly.

Front Cover

Removal

Remove the 4 mounting screws from the top-end of front luggage box.

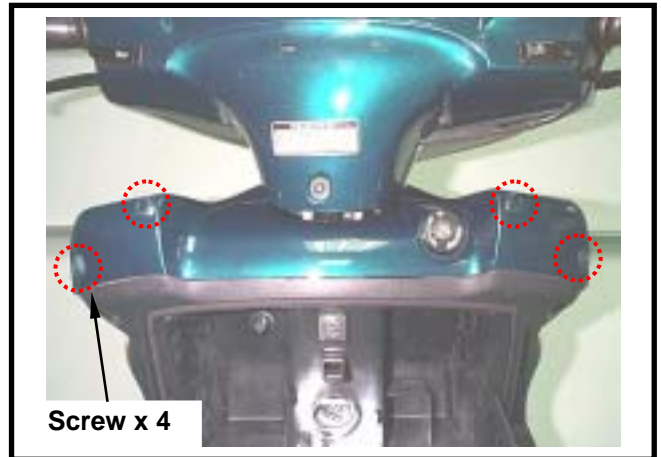

Remove the upper screw (screw x 1) from the front fender.



Remove the lower screw (screw x 1) from the front fender.

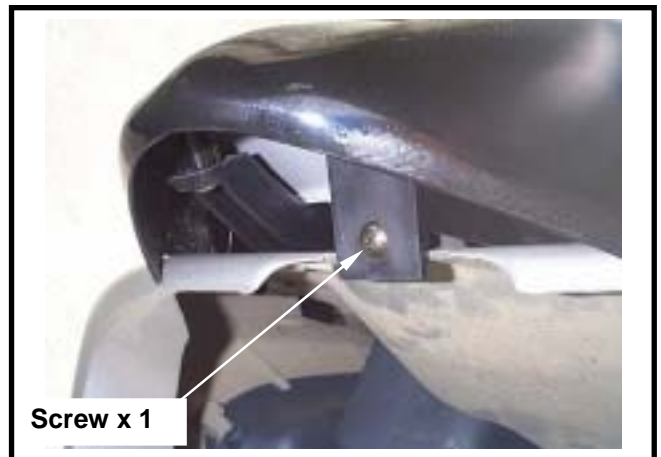

Remove the front lamp wire connector and then the front fender.

Installation

Install according to the reverse procedure of removal.



12. Body Cover

Handlebar Cover

Removal

Remove the handlebar rear cover (screw x 5).
Disconnect the wire connectors of left & right switches.

Remove the handlebar rear cover.

Caution

- Open the hooks on the two end-section of the handlebar cover as removing the cover. Then, remove the handlebar cover. Do not pull it forcedly to avoid to breaking the hooks.

Remove the front cover, and odometer wire connector.

Remove the odometer cable.

Remove the handlebar front cover and odometer set. (screw x 4)

Remove the odometer cover. (screw x 3)

Disassemble the odometer cover and the odometer set. (screw x 2)

Installation

Install according to the reverse procedure of removal.

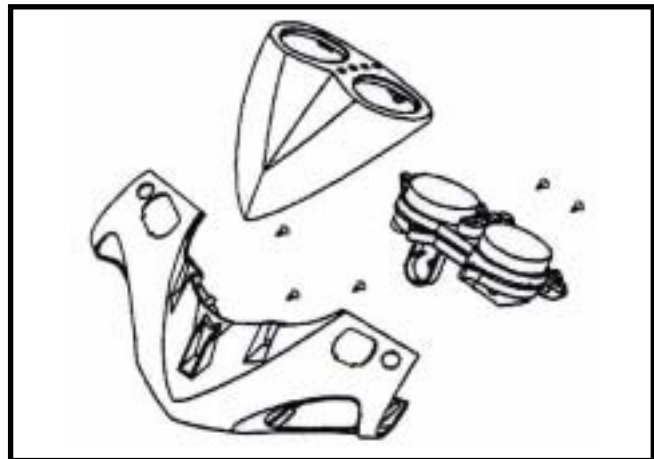
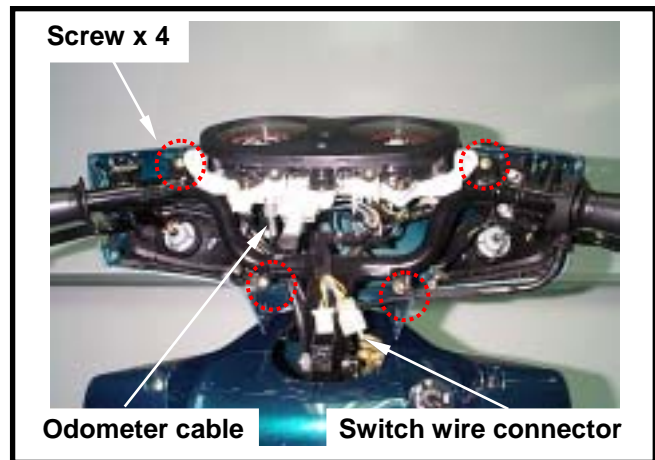



Front Fender

Removal

Remove the front guard screws. (left & right x 2)



Remove the front guard.

Installation

Install according to the reverse procedure of removal.



12. Body Cover

Front Under Spoiler

Removal

Remove the front fender, front brake system, and odometer cable, as well as the front wheel.



Remove the inner box screw (left & right each side x 3), the mounting bolts (2 bolts) of foot plate, and 1 screw on the left & right each side of side cover.

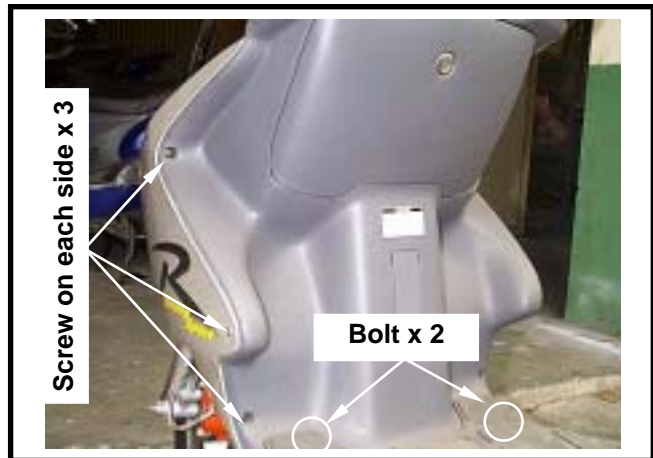

Remove the screw (screw x 4) from the top-end of front under spoiler.

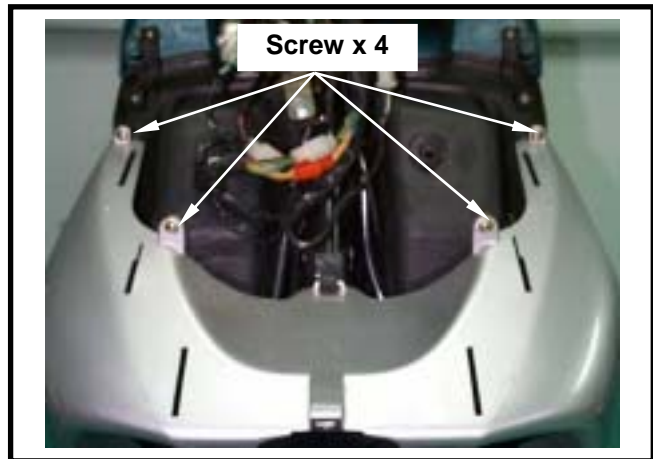

Bend the frame hook slightly straight on the front under spoiler, and then remove it.

Installation

Install according to the reverse procedure of removal.

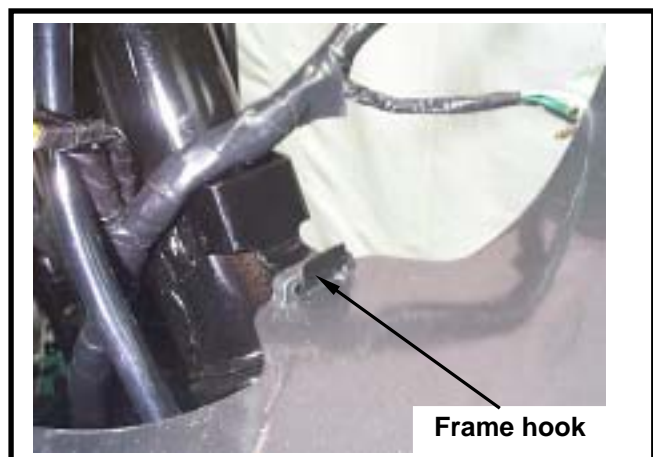

Inner Box

Removal

Remove the front under spoiler firstly.
 Remove the inner box screw (left & right each side x 3), the mounting bolts (2 bolts) of foot plate, and 1 screw on the left & right each side of side cover.

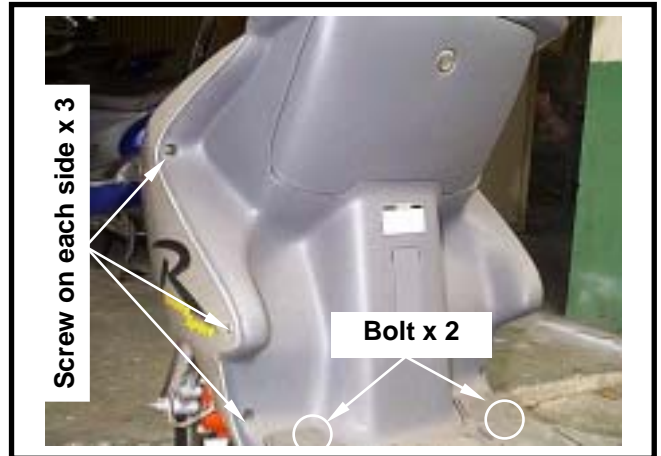

Remove the inner nut of the inner box.



Bend out all wire strap.
 Disconnect the wire connector of ECU, and the diagnosis connector.
 Remove the screw (screw x 4) from the top-end of front under spoiler.

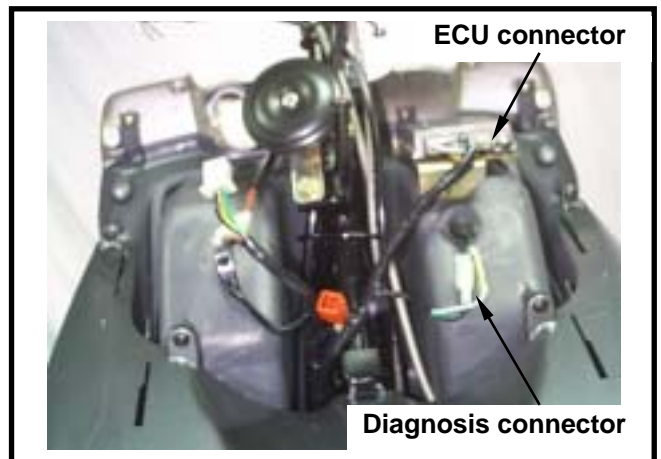

Take out the front luggage.

Installation

Install according to the reverse procedure of removal.



12. Body Cover

Center Cover

Removal

Remove the 1 upper screw inside of the luggage box.



Remove the lower 2-screws in front of the center cover.

Take out the center cover.

Installation

Install according to the reverse procedure of removal.

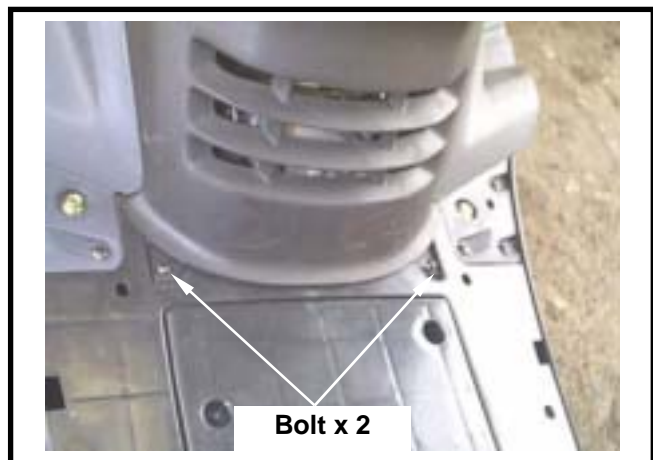

Luggage Box

Removal

Open the seat.

Remove the 1 upper screw inside of the front luggage box.

Remove the 2 mounting nuts and 2 bolts of the luggage box.

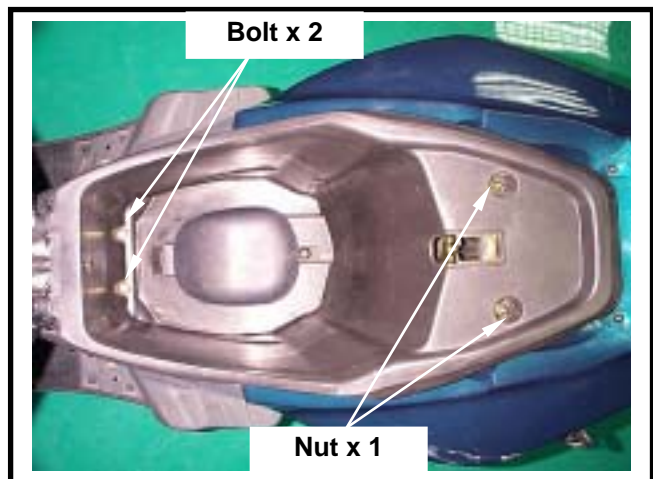

Lift the luggage box up by pushing the luggage box & seat upward.

Installation

Install according to the reverse procedure of removal.



Rear Carrier

Removal

Remove the hex-socket bolts (bolt x 4) of the rear carrier.

Caution

Do not open the fuel tank cap as removing the bolts so that prevent from bolts falling into the fuel tank.

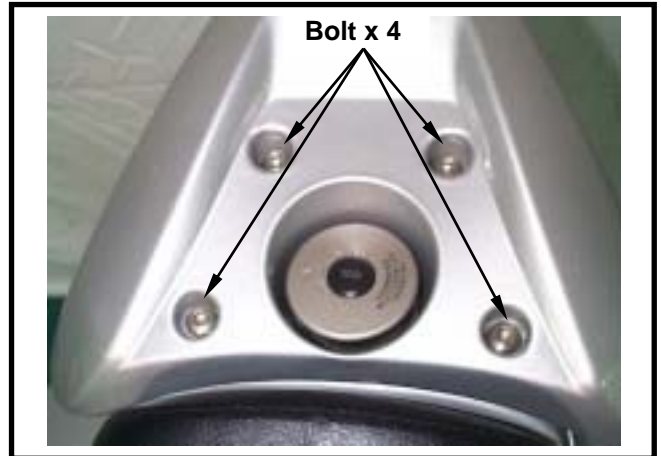

Open the fuel tank cap with key.



Take out the fuel/vapor separator.
Remove the rear carrier.

Installation

Install according to the reverse procedure of removal.



12. Body Cover

Body Cover

Removal

Remove the rear carrier, luggage box and seat firstly.

Remove the body cover mounting screw. (2 screws on each side)



Gently split out the body cover a little bit with hands and then lift the cover up slightly. Then, remove the seat locker cable.

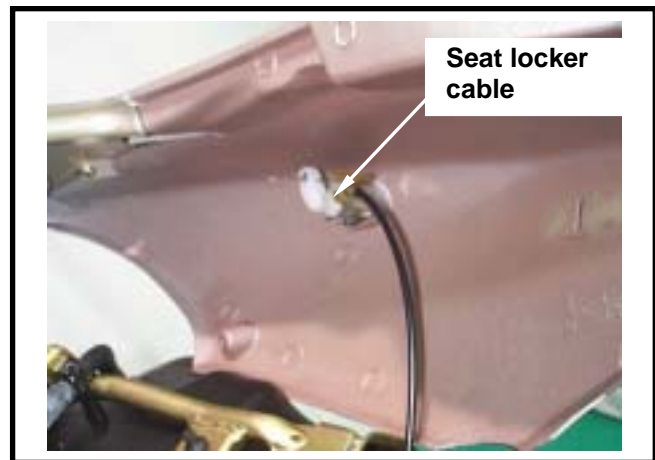

Remove the body cover.

Installation

Install according to the reverse procedure of removal.



Left & Right Side-Foot Plates

Removal

Remove the foot connection screws & bolt. (3 screws & 1 bolt on left & right each side)

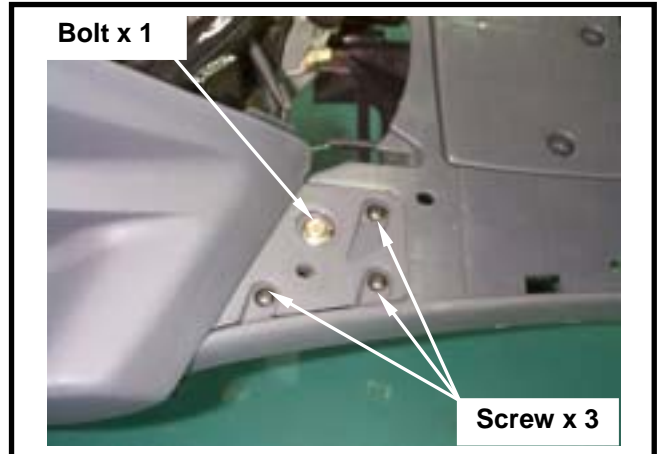

Remove the rear connection screws. (1 screw on left & right each side)

Installation

Install according to the reverse procedure of removal.

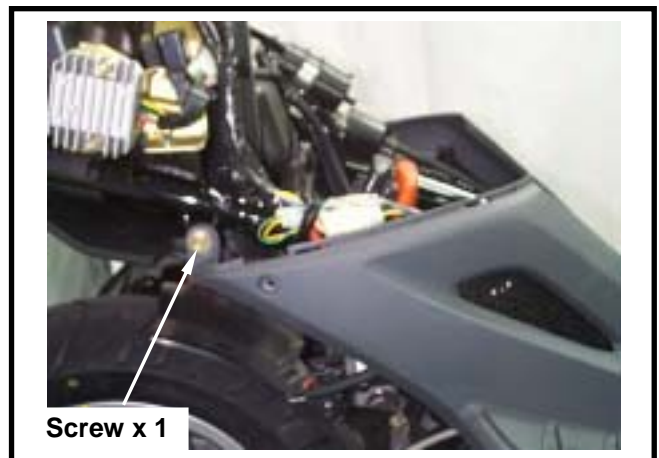

Left & Right Side-Covers

Remove the mounting screws. (2 screws on left & right each side)



Pull out the side-cover backward so that the front clipper can be separated.
Remove the side-covers.

Installation

Install according to the reverse procedure of removal.



12. Body Cover

Floor Panel

Removal

- Remove the center cover, luggage box, body side covers, and body cover firstly.
- Remove the front mounting bolts (bolt x 2) of the floor panel.

Remove the battery cover. (screw x 3)

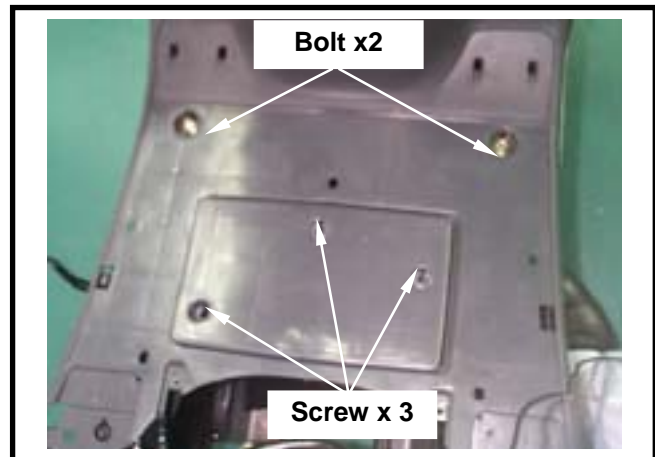

Remove the battery bracket (screw x 2) and power cables.

Take out the battery.



Remove the bottom mounting screws from the floor panel, and then the floor panel.

Installation

Install according to the reverse procedure of removal.

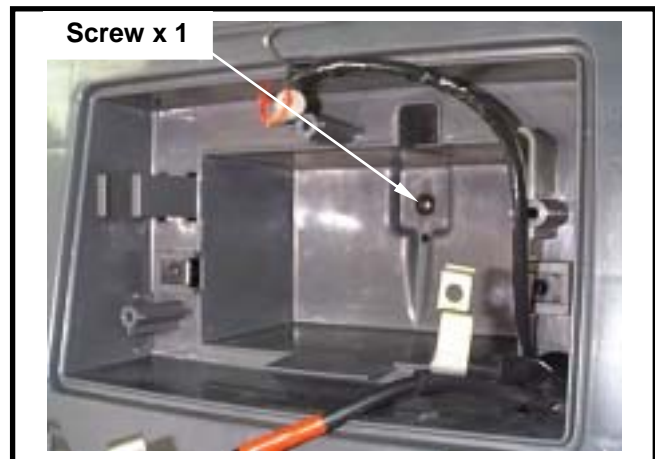



Rear Fender

Removal

Remove the upper bolts (bolt x 2) from the rear fender.

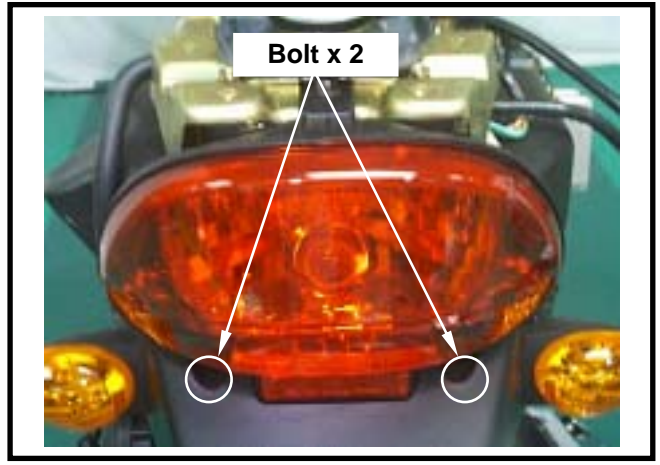

Remove the left & right side bolt (1 bolt on each side) from the rear fender.
Remove the rear turning signal lamp wire, and then the rear fender.

Installation

Install according to the reverse procedure of removal.



12. Body Cover



NOTES:

Front Disc Brake System 13-1	Brake Fluid Replacement / Air-Bleed 13-6
Rear Disc Brake System..... 13-2	Brake Caliper 13-7
Precautions in Operation 13-3	Brake Disc 13-8
Trouble Diagnosis 13-4	Brake Master Cylinder 13-8
Hydraulic Brake System Inspection 13-5	

Front Disc Brake System

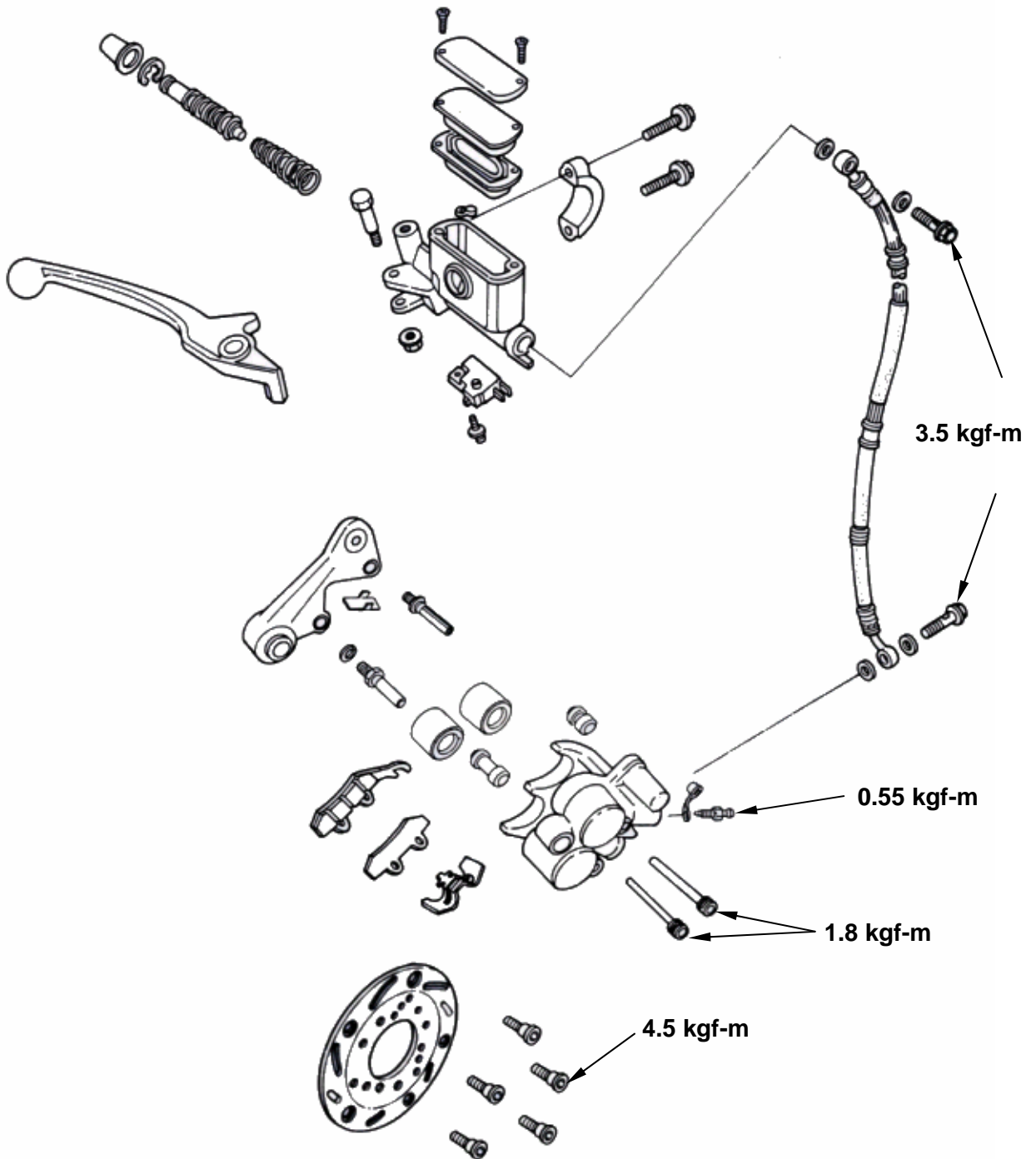

13. Brake

Rear Disc Brake System

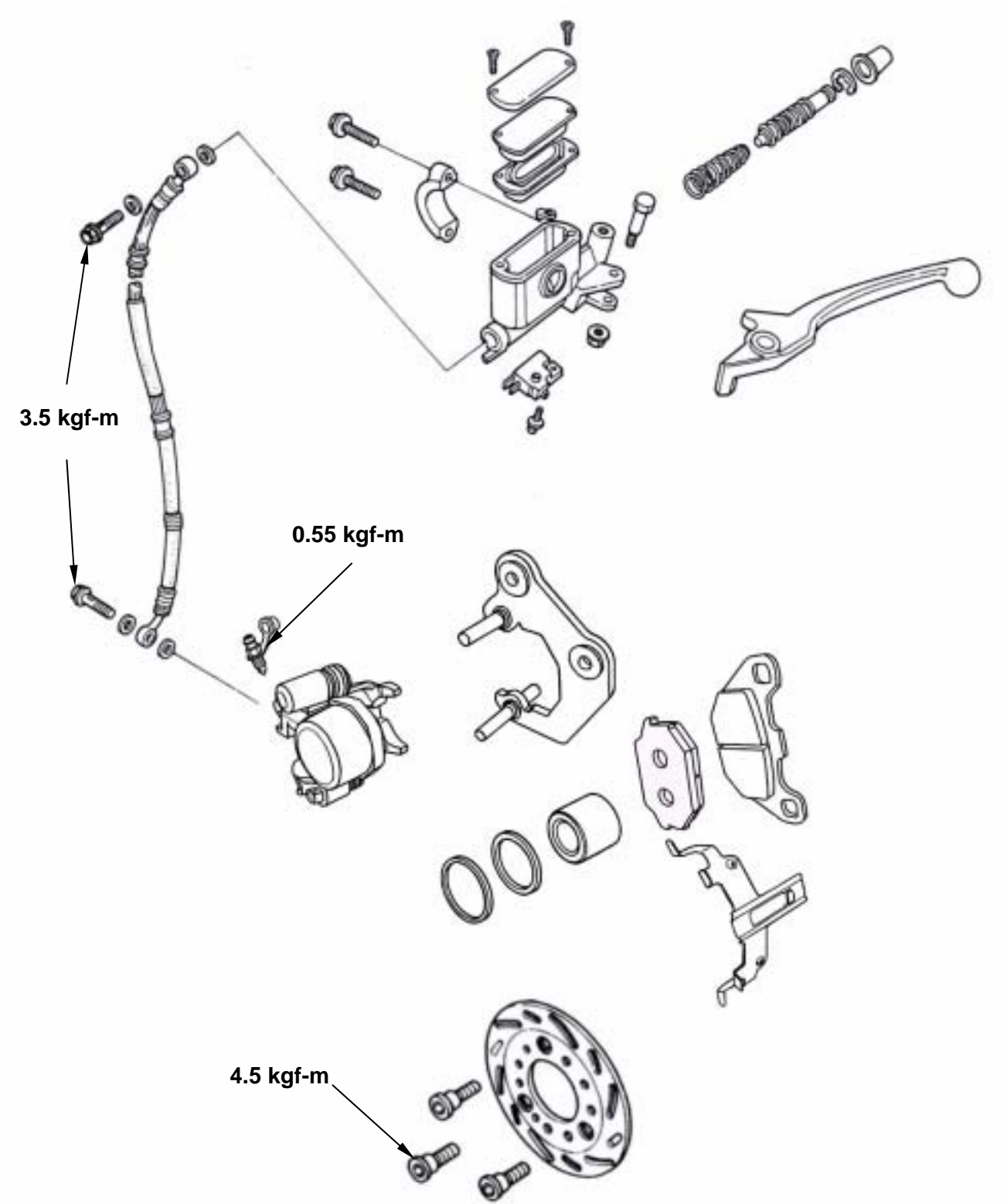

Precautions in Operation

Caution

Inhaling asbestos may cause disorders of respiration system or cancer, therefore, never use air hose or dry brush to clean brake parts. Use vacuum cleaner or other authorized tool instead.

- The brake caliper can be removed without removing the hydraulic system.
- After the hydraulic system is removed, or the brake system is felt to be too soft, bleed the hydraulic system.
- While refilling brake fluid, care should be taken not to let the foreign material entering into the brake system.
- Do not spill brake fluid on the painted surfaces, plastic or rubber parts to avoid damage.
- Check the operation of the brake system before you go.

Specifications

Unit: mm

Item	Standard	Limit
The thickness of front brake disc	4.000	2.500
Front brake disc eccentricity	0.100 or less	0.300
Master cylinder inner diameter	11.000~11.043	11.055
ID of master cylinder piston	10.957~10.984	10.945
Diameter of front disc	273.000	
Diameter of rear disc	200.000	
Thickness of front disc brake lining	5.100	2.000
Thickness of rear disc brake lining	5.100	2.000

Torque values

Brake hose bolt	3.50 kgf-m
Bolt for brake caliper	3.30 kgf-m
Brake lining pin bolt	1.80 kgf-m
Cap of Brake lining pin bolt	1.00 kgf-m
Air-bleed valve	0.55 kgf-m

13. Brake

Trouble Diagnosis

Soft brake lever

1. Air inside the hydraulic system
2. Hydraulic system leaking
3. Worn master piston
4. Worn brake pad
5. Poor brake caliper
6. Worn brake lining/disc
7. Low brake fluid
8. Blocked brake pipe
9. Warp/bent brake disc
10. Bent brake lever

Hard operation of brake lever

1. Blocked brake system
2. Poor brake caliper
3. Blocked brake pipe
4. Seized/worn master cylinder piston
5. Bent brake lever

Uneven brake

- Dirty brake lining/disc
- Poor wheel alignment
- Clogged brake hose
- Deformed or warped brake disc
- Restricted brake hose and fittings

Tight brake

- Dirty brake lining/disc
- Poor wheel alignment
- Deformed or warped brake disc

Brake noise

- Dirty lining
- Deformed brake disc
- Poor brake caliper installation
- Imbalance brake disc or wheel

Hydraulic Brake System Inspection

Inspection

Visual inspect for brake fluid leaking or damage. Check if brake hose connection loosen with wrench and turn the handlebar from right to left motion or press down the shock absorber to check if there is something is interfered with the brake system or brake components.

Operate the brake system and check the brake lining. Check the front brake from front side, and replace the brake lining with new one when the brake lining wear limitation groove reaches to the brake disc.

Park the motorcycle on a flat ground and check its brake fluid level.

Recommended brake fluid: WELL RUN (DOT 3) brake fluid

⚠ CAUTION

- The fluid level will not be correct if parking the motorcycle in title or just parking. It has to waiting for around 3~5 minutes.
- Never use faked brake fluid to prevent from chemical reaction.
- It has to apply with same brand brake fluid to sure the brake performance.

BRAKE FLUID ADD

Turn the handlebar to let the master cylinder in horizontal position before removed the master cylinder cap.

Place a rag onto painting, plastic or rubber components when conduct brake system maintenance.

⚠ CAUTION

- Do not over the upper level when adding brake fluid and avoid to spilling brake fluid on painted surfaces, plastic or rubber components to result in their damages.

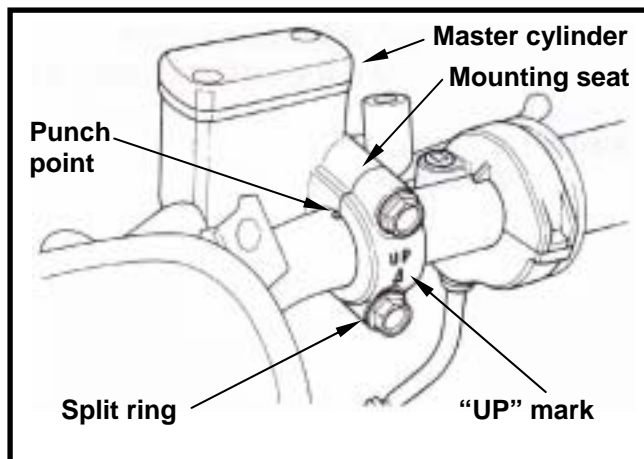
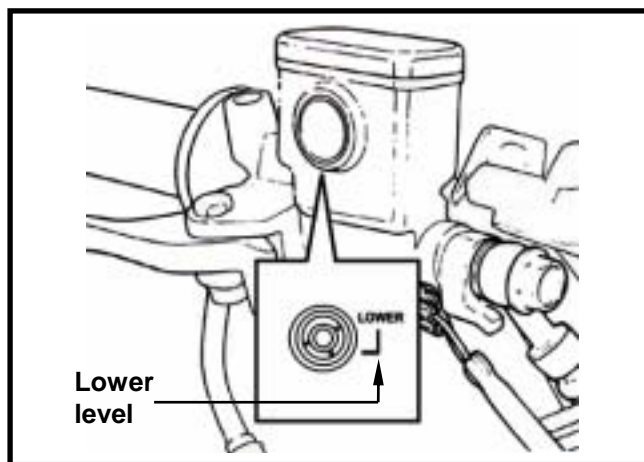
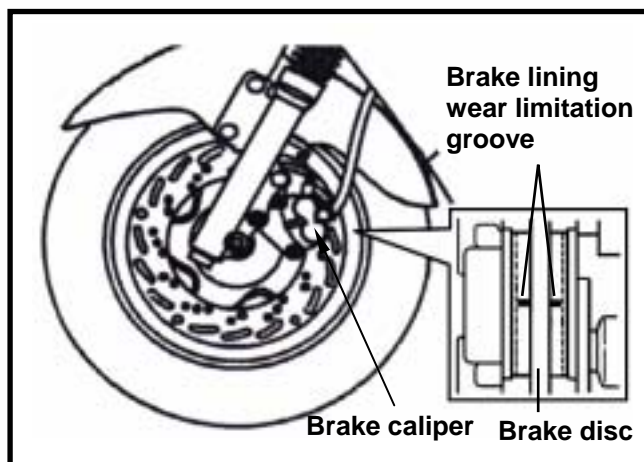
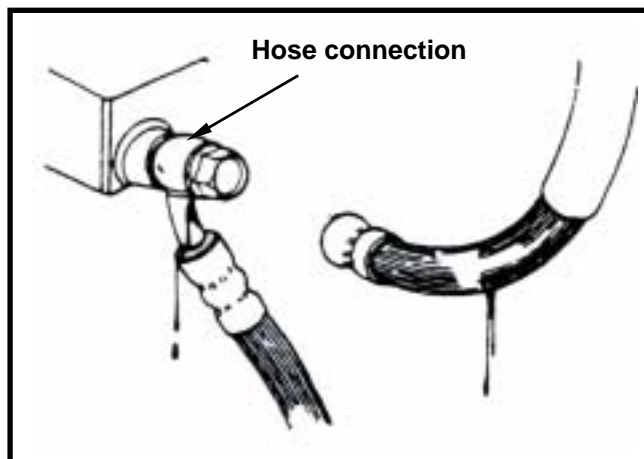

13. Brake

Remove the master cylinder cap and diaphragm. Add good quality brake fluid and it has to add same brand brake fluid into the master cylinder. Clean dirty brake disc.

CAUTION

The dirty brake lining or disc will reduce the brake performance. The mixed non-compatible brake fluid will reduce brake performance. Foreign materials will block the system causing brake performance to be reduced or totally lost.

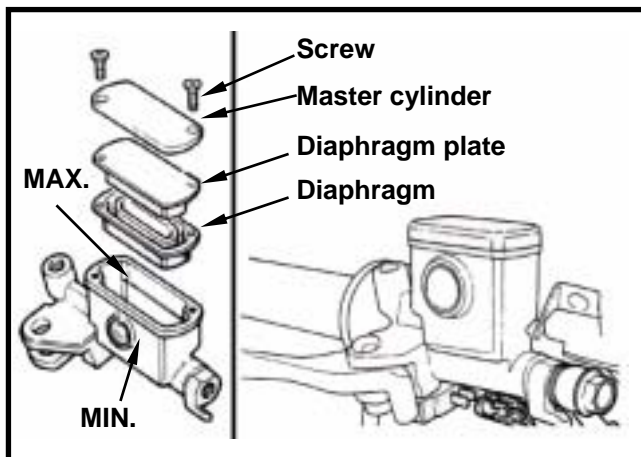

Brake Fluid Replacement/Air-Bleed

Connect drain hose to drain valve. Open the drain valve on the caliper and hold and release the brake lever alternatively until the old brake fluid is entirely drained out. Close the drain valve and add specified brake fluid into the brake master cylinder.

CAUTION

To reuse the spent brake fluid will effect brake performance.

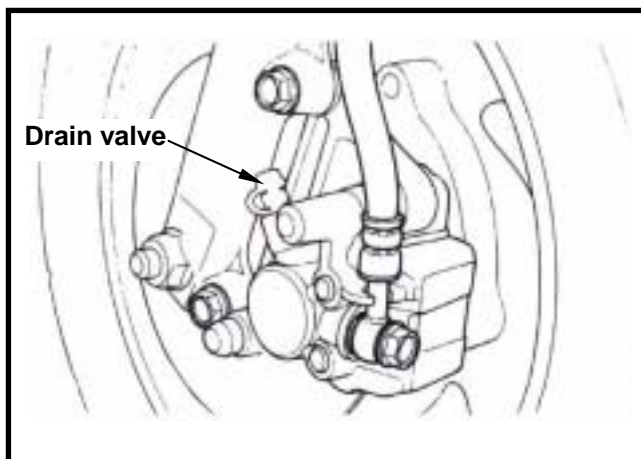

Connect one end of transparent hose to the drain valve, and put the other end into a container. Open the drain valve around 1/4 turns, and at the same time hold the brake lever until there is no air bubble in the drain hose and also feeling resistance on the brake lever.

Close the drain valve when finishing the brake system refilling fluid procedure, and operate the brake lever to check whether air bubble is in brake system or not. If brake is still soft, please bleed the system as described below.

1. Tightly hold the brake lever and open the drain valve around 1/4 turns, and then close the valve.

CAUTION

- Do not release the brake lever before the drain valve is closed.
- Always check the brake fluid level when carrying out the air bleeding procedure to avoid air entering into the system.

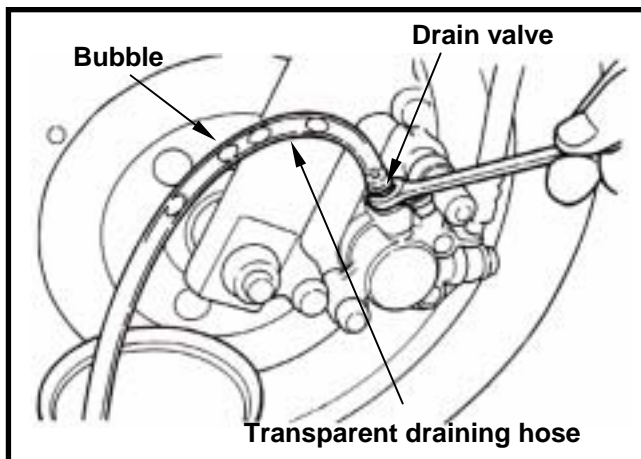

2. Slowly release the brake lever, and wait for a few seconds until it reaches its top position.
3. Repeat the steps 1 and 2 until there is no air bubble at the end of the hose. Tightly close the drain valve.
4. Make sure the brake fluid is in the UPPER level of the master cylinder, and refill the fluid if necessary.
5. Cover the cap.

Brake Caliper

Removal

Place a container under the brake caliper, and loosen the brake hose bolt and finally remove the brake hoses.

CAUTION

- Do not spill brake fluid on painted surfaces.
- The exhaust pipe has to be removed before remove the rear brake caliper.

Remove the bolt cap, and loosen the lining guide bolt.

Remove two caliper bolts and the caliper.

INSTALLATION

Install the brake caliper and tighten the attaching bolts securely.

Torque: 3.3 kgf-m

CAUTION

- Use M8 x 35 mm flange bolt only.
- Long bolt will impair the operation of brake disc.

Tighten the lining guide bolt.

Torque: 1.8 kgf-m

Install the bolt cap.

Torque: 1.0 kgf-m

Use two seal washers and hose bolts to lock the hose and brake caliper in place.

Torque: 3.5 kgf-m

Refill up the brake fluid to the reservoir and make necessary air bleeding.

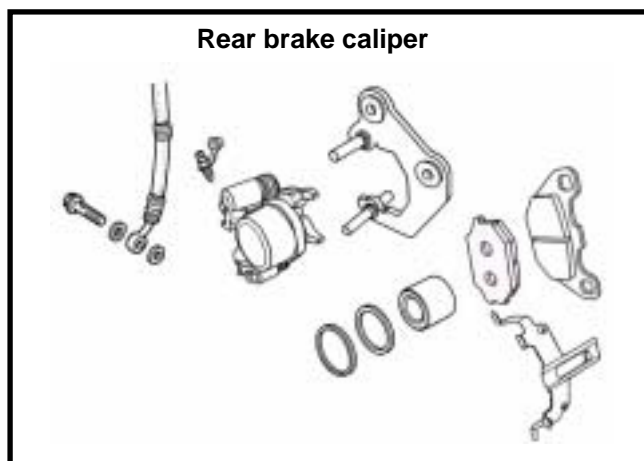
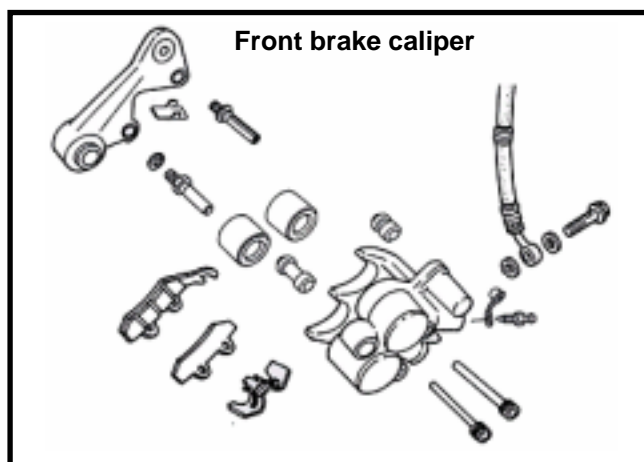
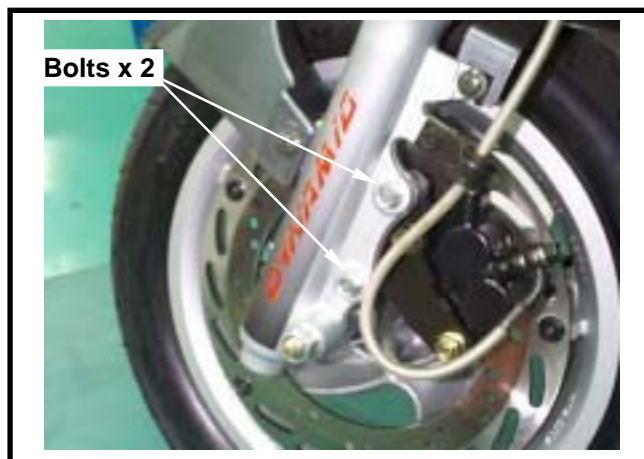

13. Brake

Brake Disc

Inspection

Visually check the brake disc for wear or break. Measure the thickness of the disc at several places. Replace the disc if it has exceeded the service limit.

Allowable limit: 2.0 mm

Remove the brake disc from wheel. Check the disc for deformation and bend.

Allowable limit: 0.30 mm

⚠ CAUTION

- Do not let grease touch to the brake disc that will cause brake performance.
- Do not clean the brake lining with air gun because the lining is contained asbestos. Operator should wear mask & glove and use vacuum cleaner to clean the brake lining.

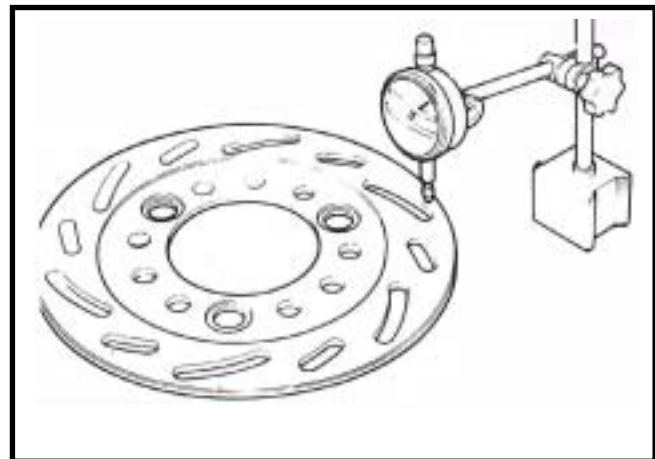
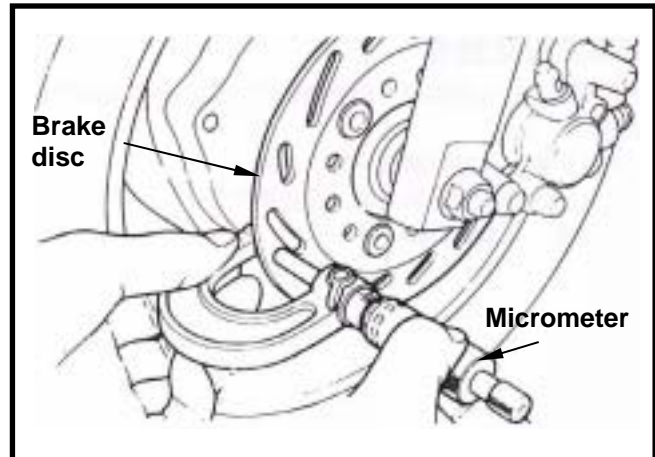

Brake Master Cylinder

Removal

⚠ CAUTION

Do not let foreign materials enter into the cylinder.

⚠ CAUTION

The whole set of master cylinder, piston, spring, diaphragm and clip should be replaced after removal.

Remove the front and rear handlebar guards.
 Remove the leads of brake lamp switch.
 Drain out the brake fluid.
 Remove the brake lever from the brake master cylinder.
 Remove the brake hose.
 Remove the master cylinder seat and the master cylinder.
 Remove the rubber pad.
 Remove the clip.
 Remove the piston and the spring.
 Clean the master cylinder with recommended brake fluid.

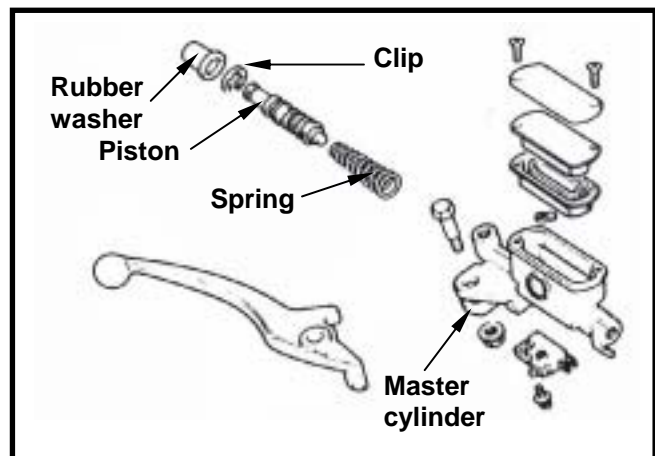
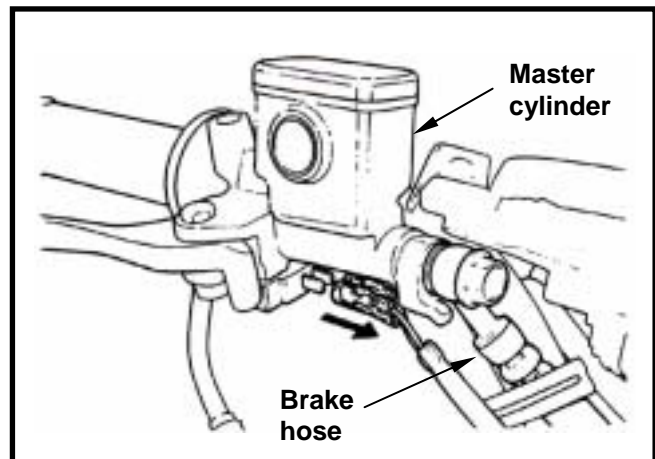

Inspection

Check the master cylinder for damage or scratch. Replace it if necessary.

Measure the cylinder inner diameter at several points along both X and Y directions.

Replace the cylinder if the measured values exceed allowable limit.

Allowable limit: 11.055 mm

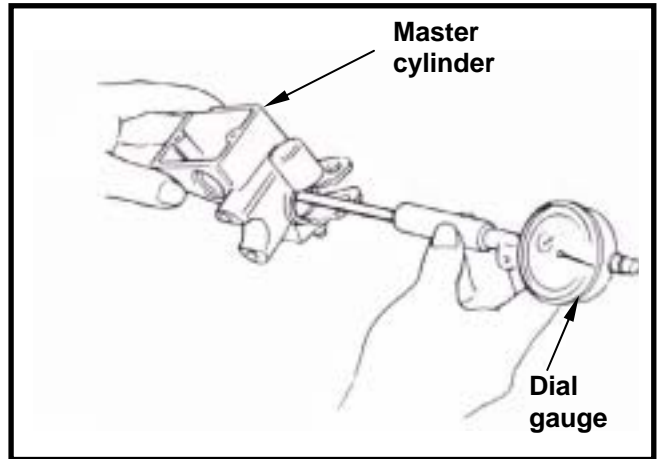

Measure the outer diameter of the piston.

Replace the piston if its measured value exceeds allowable limit.

Allowable limit: 10.945 mm

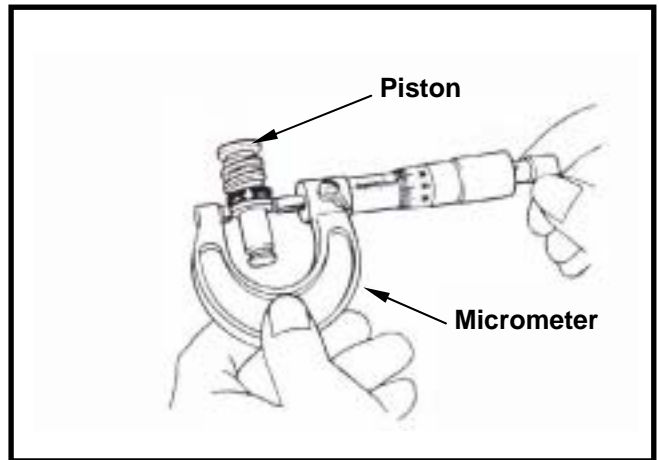

Assembly



CAUTION

- It is necessary to replace the whole set comprising piston, spring, piston cup, and clip.
- Make sure there is no dust on all components before assembling.

Apply clean brake fluid to the piston cup, and then install the cup onto the piston.

Install the larger end of the spring onto the master cylinder.

The master cup's cavity should be face inside of master cylinder when installing the master cup.

Install the clip.

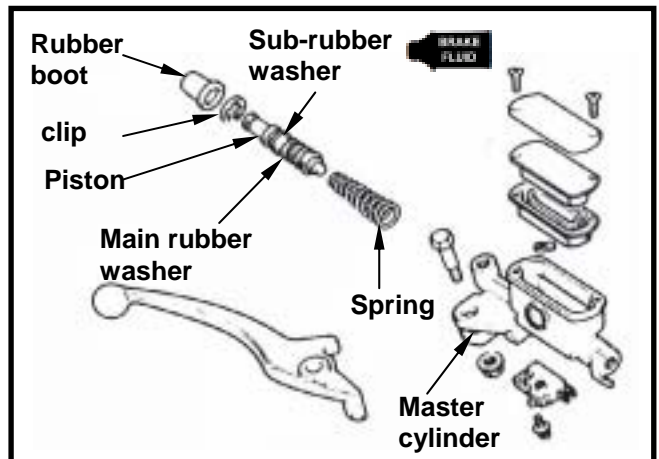

CAUTION

- Never install cup lip in the opposite direction.
- Make sure the clip is seated securely in the groove.

Install the rubber pad into groove properly.

13. Brake

INSTALLATION

Place the master cylinder onto handlebar, and install the split ring and bolts. The "UP" mark on the split ring should face upward.

Align the split ring on the master cylinder seat with the alignment point on the handlebar.

Tighten the upper bolt of the seat to specified torque value, and then tighten lower bolt to the same specified torque value.

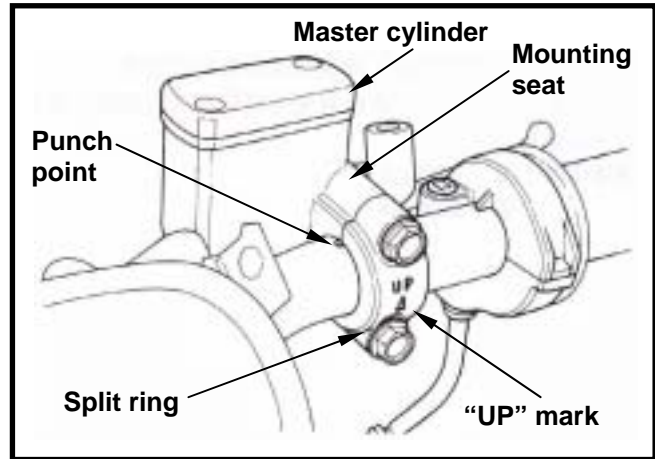

Install the brake lever, and connect leads to brake lamp switch.

Connect brake hoses with 2 new washes. Tighten the brake hose bolt to the specified torque value.

Torque value: 3.5 kgf-m

Make sure the hose is installed correctly.

⚠ CAUTION

Improper routing may damage leads, hoses or pipes.

⚠ CAUTION

Kink of brake leads, hose or pipe may reduce brake performance.

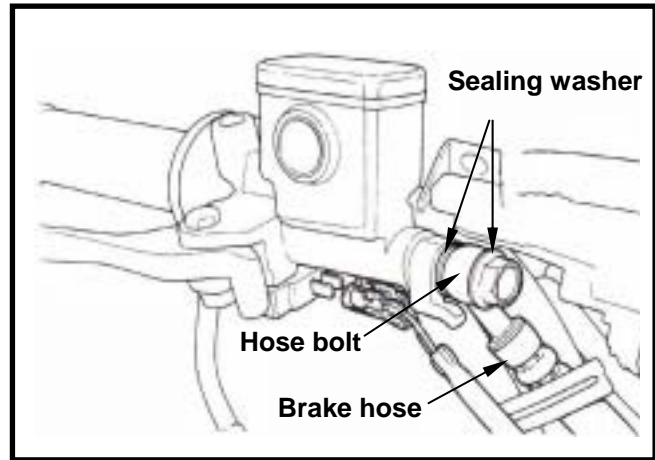

Add specified brake fluid and bleed the system and conduct the air-bleeding job for the system.

14. Steering/Front Wheel/Front Shock Absorber

Mechanism Illustration.....	14-1	Front Wheel.....	14-4
Precautions in Operation.....	14-2	Front shock absorber	14-7
Trouble diagnosis.....	14-2	Front fork/steering column.....	14-7
Steering Handlebar.....	14-3		

Mechanism Illustration

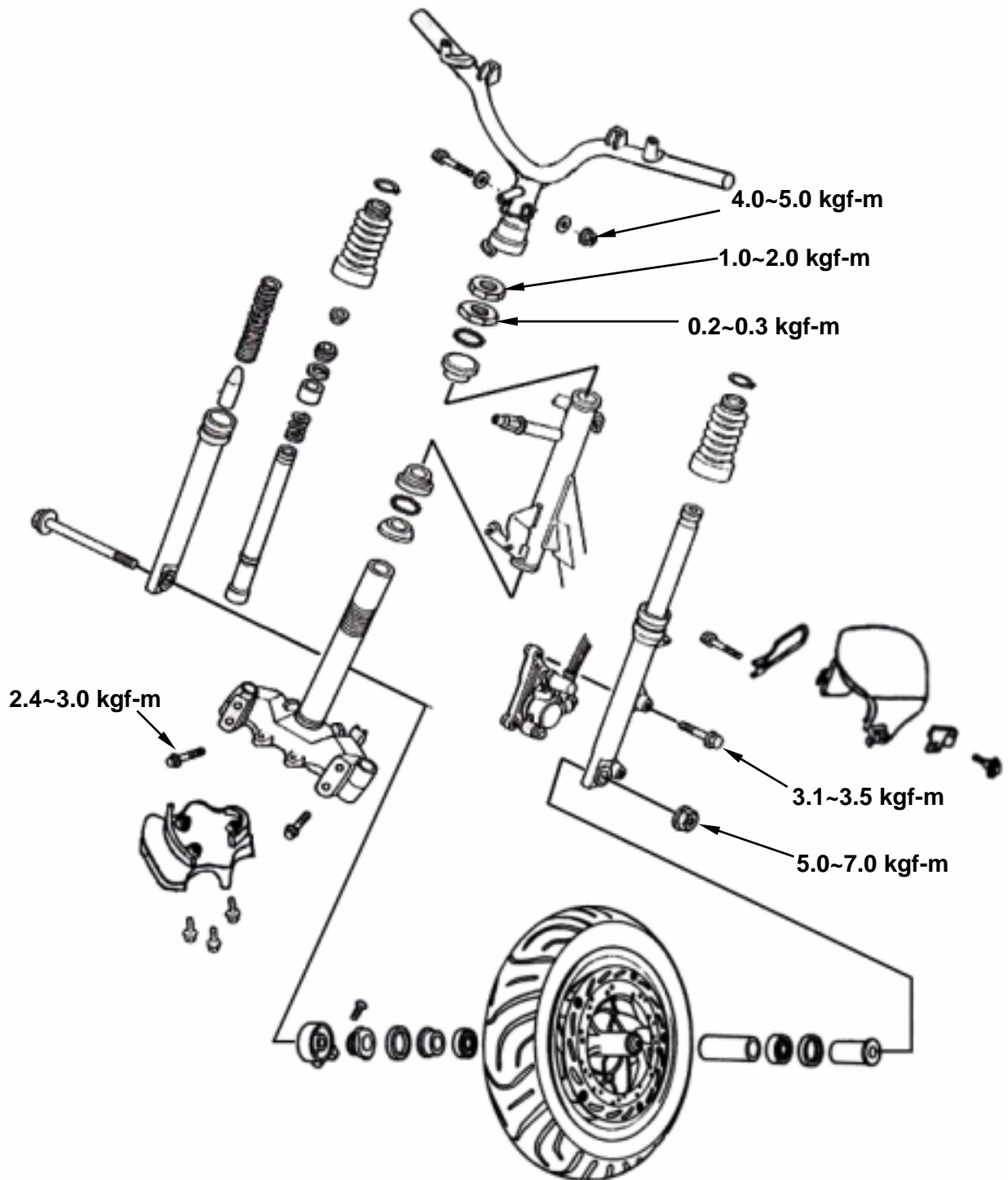

14. Steering/Front Wheel/Front Shock Absorber

Precautions in Operation

General Information

- Before remove front wheel, use a jack to lift the body until front wheel free of ground, and take care not to rotate body in reverse.
- Be careful not to allow oil or grease get on brake drum or linings.

Torque values

Front wheel axle	5.0~7.0 kgf-m
Steering handlebar nut	4.0~5.0 kgf-m
Steering column top cone sliding ring	0.2~0.3 kgf-m
Steering column lock nut	1.0~2.0 kgf-m
Speedometer cable nut	0.15~0.3 kgf-m
Front shock absorber: Upper nut	2.4~3.0 kgf-m

Tools

Special service tools

- Steering column wrench
- Bearing remover
- Inner type bearing remover
- Attachment, 32 × 35 mm
- Attachment, 42 × 47 mm
- Steering column nut wrench
- Steering column top cone ring nut wrench

Trouble diagnosis

Hard steering stem

- Over tightening of steering stem lock nut
- Damaged steering stem steel ball and steering stem bearing seat
- Insufficient tire pressure

Steering stem off center

- Uneven left/right cushion
- Bend fork
- Bent front wheel/tire offset

Front wheel wobbling

- Bent wheel rim
- Loose wheel axle nut
- Poor wheel or wearing
- Too much clearance on wheel bearing

Soft front suspension

- Front shock absorber spring worn out
- Oil leaking on cushion oil ring

Front suspension noise

- Bent shock absorber linkage
- Loosen shock absorber nut



14. Steering/Front Wheel/Front Shock Absorber

Steering Handlebar

REMOVAL

Remove handlebar front & rear cover and the front cover (refer to chapter 12).

Disc Brake

Remove the 2 bolts of the brake master cylinder, and then take out the master cylinder and the split ring.

⚠ Caution

Do not operate the front brake lever to avoid to pressing out the brake lining when removing the master cylinder.

Remove throttle handlebar housing screw and then remove the handlebar, throttle cable, and handlebar upper housing & under housing.

Remove the mounting bolt of the rear brake cylinder. (bolt x 2)
Take out rear brake cylinder.

With a wrench to hold the handlebar bolt and then remove the nut.
Take out the handlebar after removed the bolt.

Installation

Install the handlebar according to the reverse procedure of removal.

Apply with some grease onto the handlebar moving parts when installing the throttle handlebar housing, throttle handlebar, and throttle cable.

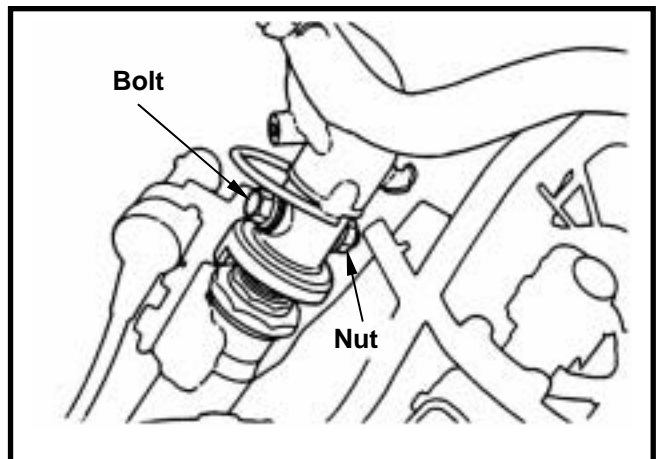
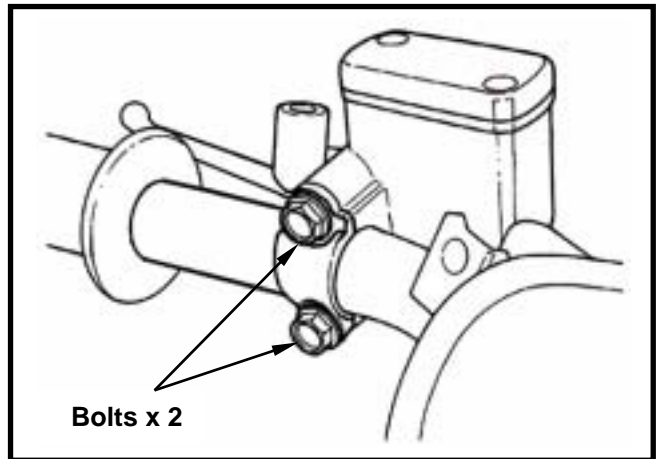
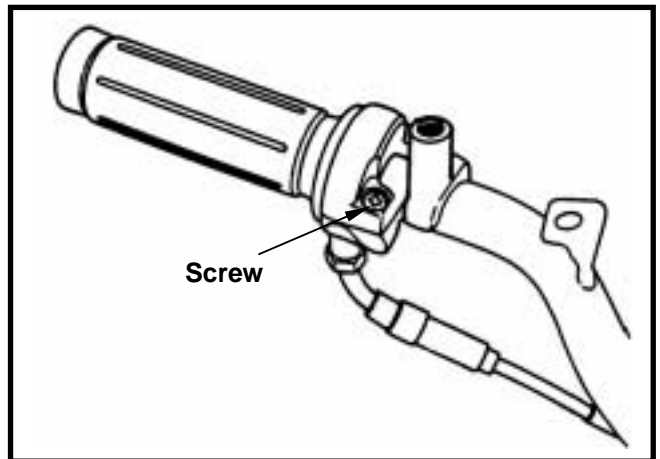
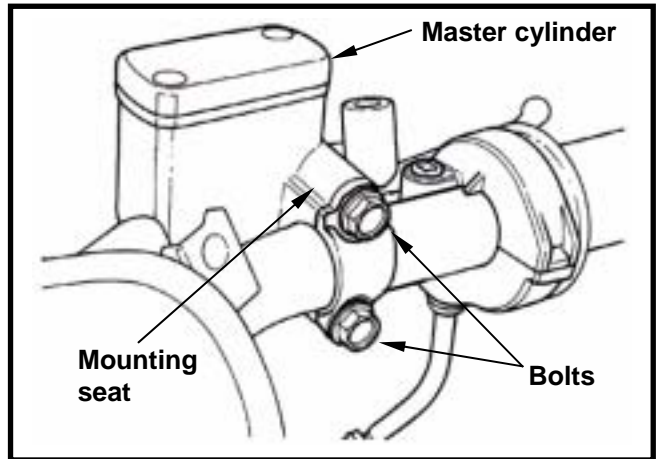

14. Steering/Front Wheel/Front Shock Absorber

Front Wheel

Removal

Support body bottom and lift front wheel free of ground.
Remove the screw, and disconnect speedometer cable from the gear box.

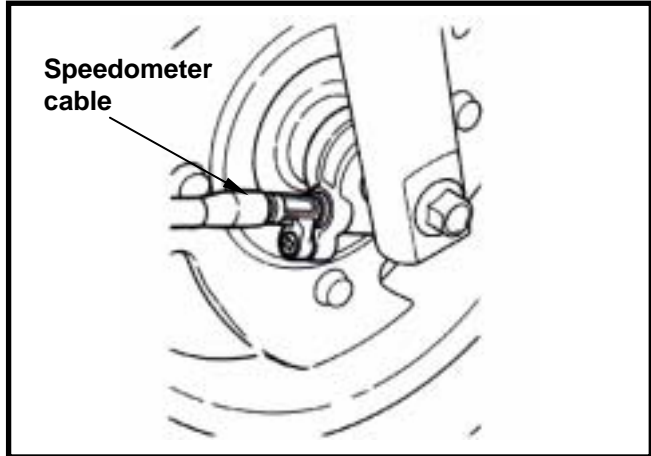

Remove the wheel axle nut and pull out the axle.
Then, remove the front wheel.

⚠ Caution

Do not operate the front brake lever to avoid to pressing out the brake lining when removing the master cylinder.

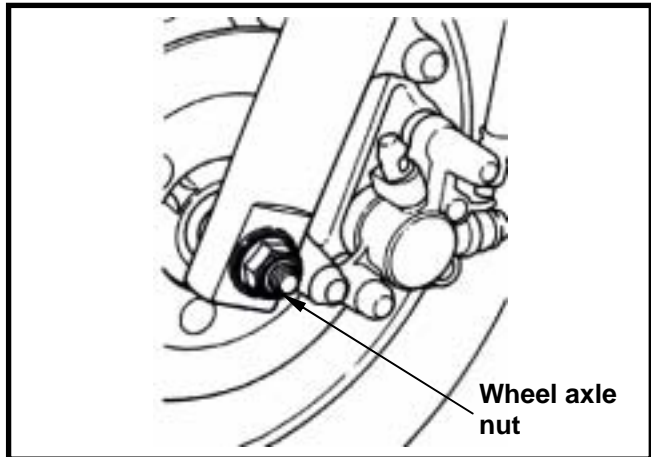

Inspection

Wheel axle

Set the axle in V-blocks and measure the run-out.
Service limit: 0.2 mm

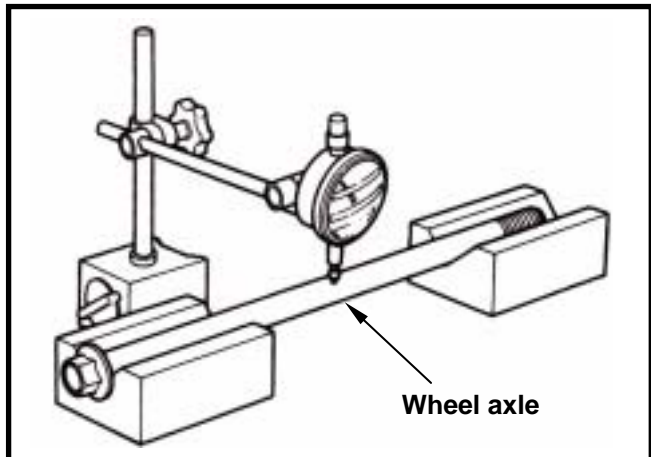

Wheel Rim

Place the wheel onto a rotated bracket.
Turn the wheel with hand and measure its wobble value with a dial gauge.

Service limit:

Radial : 2.0 mm

Axial : 2.0 mm

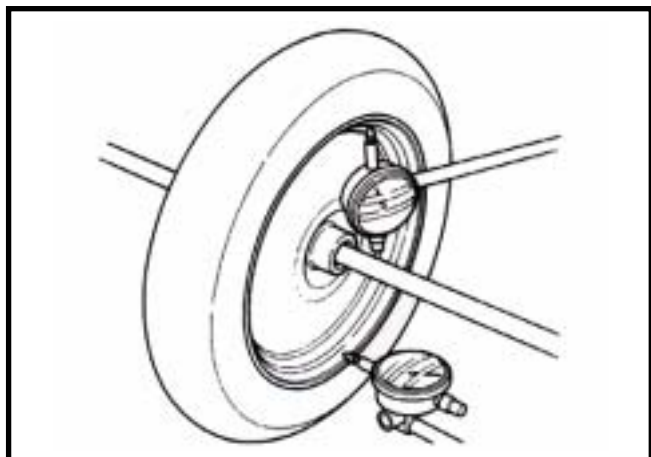

14. Steering/Front Wheel/Front Shock Absorber

Disassembly

Remove the left axle ring and dust seal.
 Remove the dust seal on the right side of speedometer gear.
 Remove the bearing with the inner type bearing remover.
 Take out the bearing spacer and then remove the other bearing.

Tool:

Inner type bearing remover.

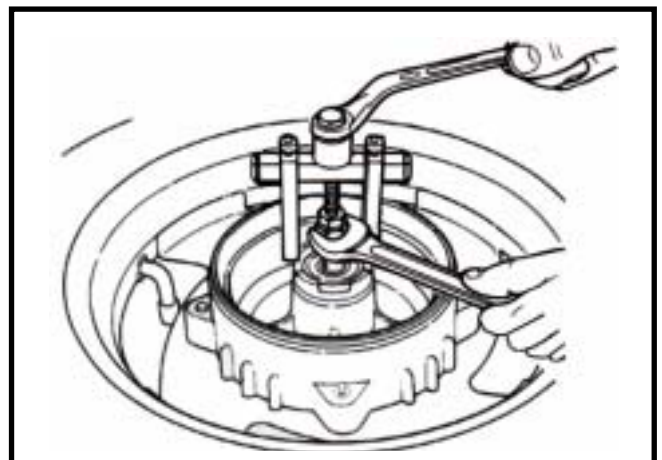
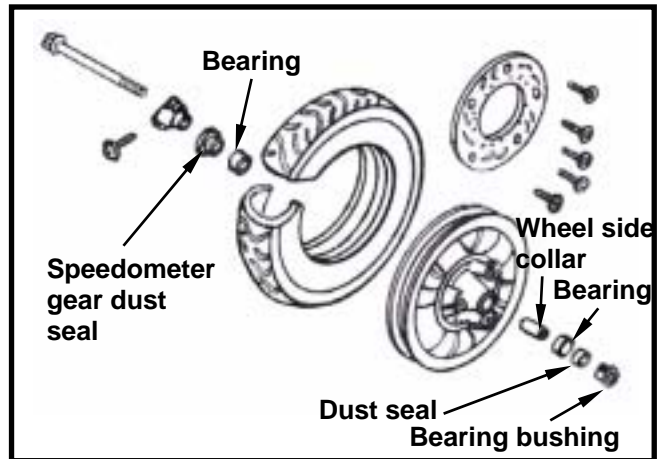

Bearing Inspection

Turn the inner race of bearing with fingers. The bearing should be turn smoothly. Also check if the outer collar is tightly connected to the wheel hub.

If the bearing do not turn smoothly, or if they are too loose in the races, or damaged, then, remove and replace the bearings with new ones.

⚠ Caution

The bearing must be replaced in pair.

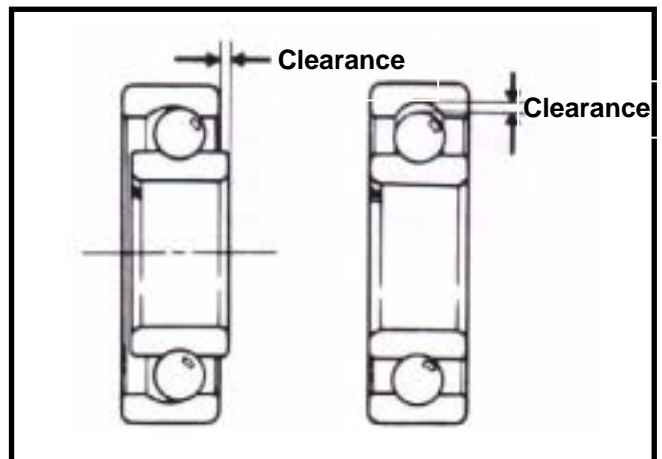

Installation

Install the bearing according to the reverse procedure of removal.
 Apply some grease into the bearing seat of the wheel hub.
 Install the left bearing onto the seat.
 Install the bearing spacer and then install the right bearing onto the seat.



14. Steering/Front Wheel/Front Shock Absorber

⚠ Caution

Do not install used bearing and replace the bearing once it has been removed.
Do not the bearing in tile motion when installing.

Tool:

C-type compressor or bearing compressor.

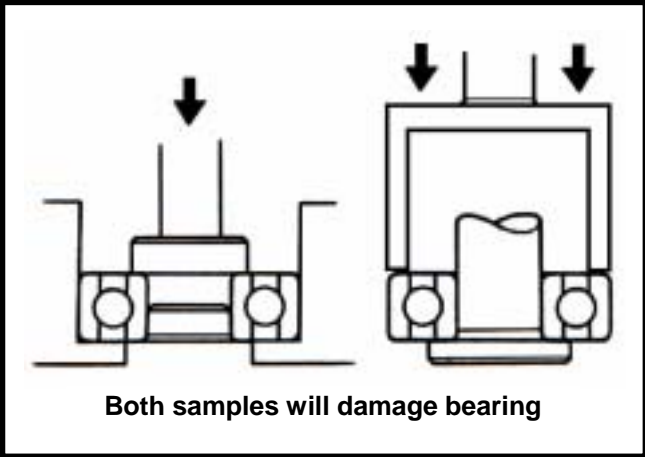

Align the flange part on the speedometer gear with the slot of wheel hub, and then install the speedometer gear box.

⚠ Caution

Contaminated brake lining will reduce brake performance so the brake lining, brake drum and disc must be free of grease.

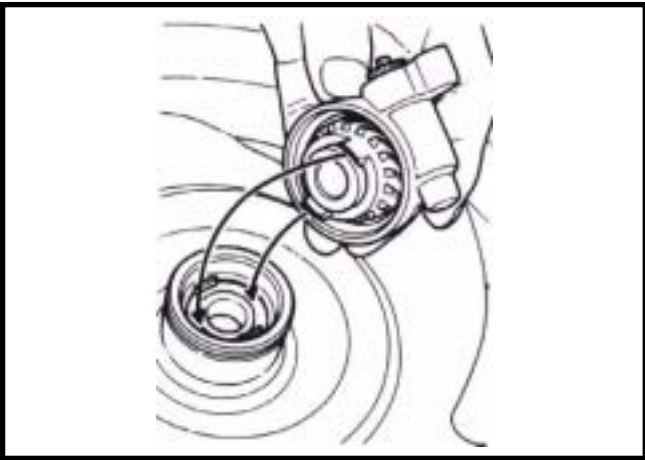

Place the front wheel between the front shock absorbers.

Align the flange part on the speedometer gear with the slot of shock absorber stopper.

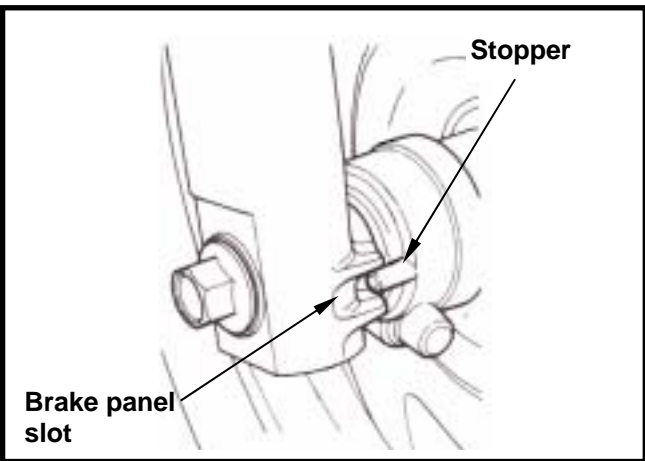

Install the front wheel axle from right shock absorber side.

Install the wheel axle nut, and tighten it to specified torque value.

Torque value: 5.0~7.0 kgf-m

Connect the speedometer cable to the speedometer gear box.

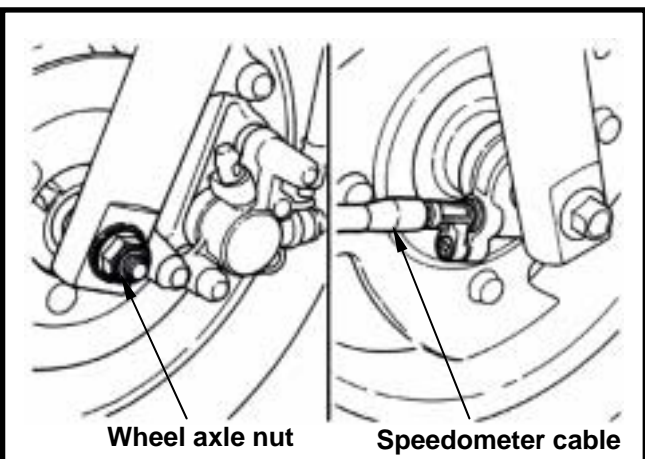



14. Steering/Front Wheel/Front Shock Absorber

Front shock absorber

Removal

Remove the front fender, front under spoiler, front cover, and front wheel as well as front brake components.

Remove the brake fluid hose clipper or cable guide on the left shock absorber. (bolt x 1)

As for disc brake, remove the cable guide on the right shock absorber. (bolt x 1)

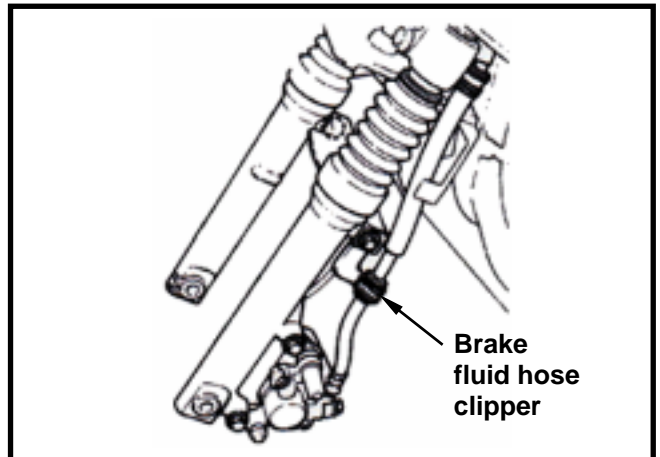

Remove the top connection bolt of the right shock absorber. (bolt x 4)

Remove the shock absorber from the front fork.

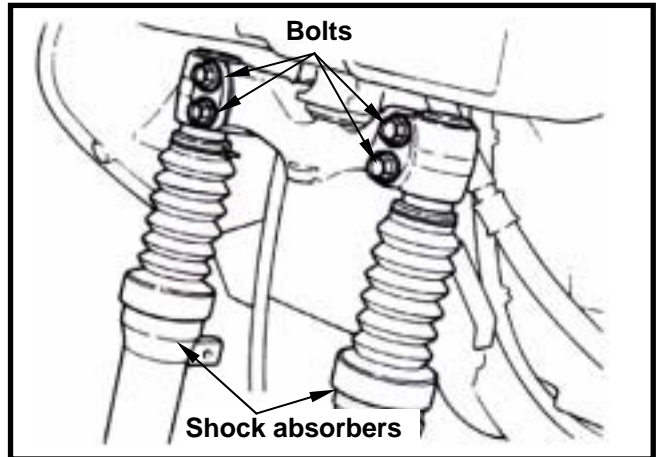

Installation

Install the shock absorbers according to the reverse procedure of removal.

Align the shock absorber top-edge with the top-end level of the front fork when installing the front shock absorber onto the front fork. Then, tighten the nut.

Torque value: 2.4~3.0 kgf-m

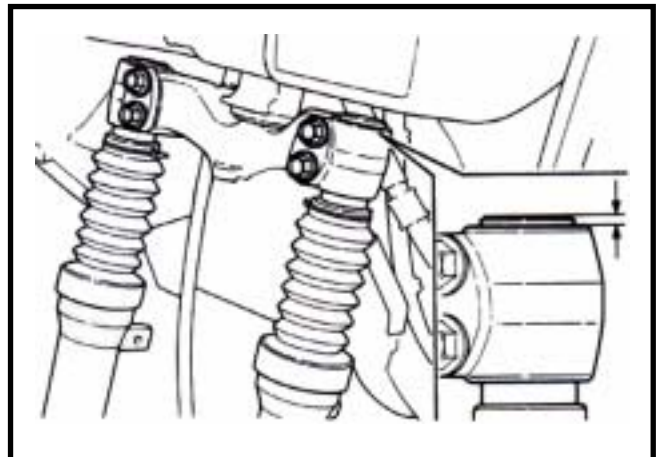

Front fork/steering column

Removal

Firstly, remove the handlebar, front wheel, front brake set, and front shock absorbers.

Remove the steering lock nut.

Remove the top cone race, and then remove the steering column.

Caution

Place the steering column bearing balls into a parts container to avoid to missing or shortage.

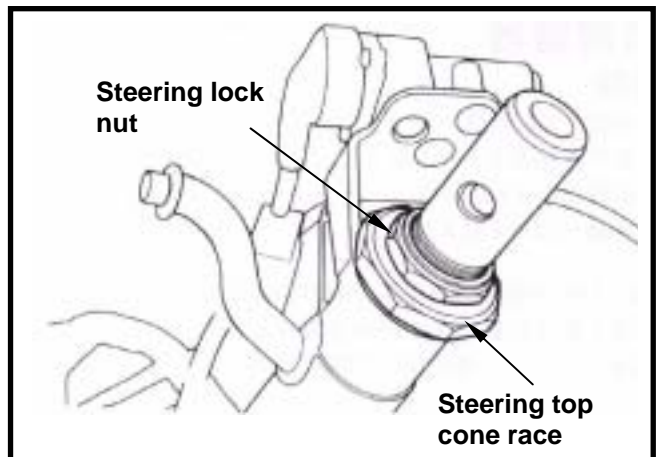

14. Steering/Front Wheel/Front Shock Absorber

With a plastic hammer to tap the steering ball race slightly, and then remove the top ball bearing race.
Remove the lower-end cone bearing race on the frame with a punch.

⚠ Caution

Do not damage the frame and the steering race.

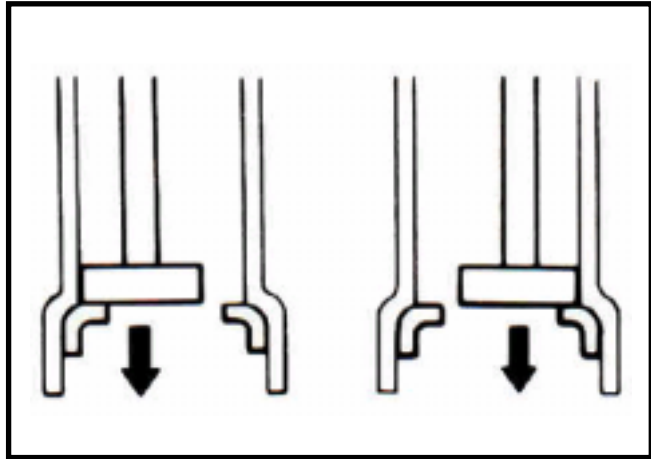

Installation

Install a new top-cone bearing race onto the top of steering column.
And then, push the lower-cone bearing seat from bottom until to locking position.

⚠ Caution

Do not let the ball bearing in title motion as installation.

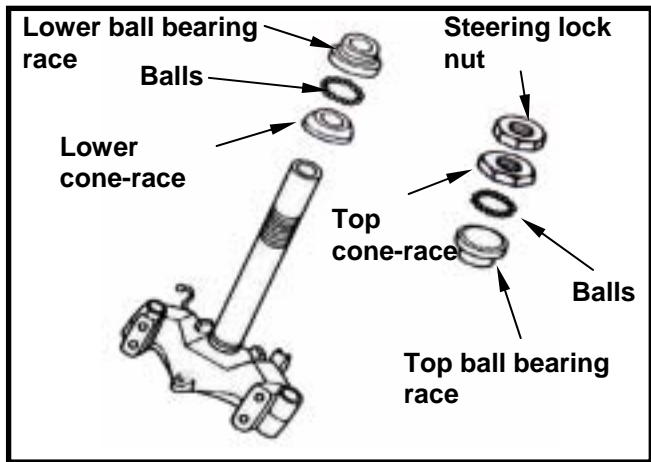

Apply with some grease onto the top & bottom bearing balls, and then install the balls into bearing race.
Press in a new lower cone-race onto the steering column, and lubricate it with grease.
Install the steering column.
Lubricate the top-cone race with grease.
Drive the cone-race into the steering column until contact with the top bearing seat no clearance.
Note, return 1/2 turn and then tighten the top cone race to specified torque. (tighten the race around 1/4~3/8 turn more.)

Torque value: 0.2~0.3 kgf-m

⚠ Caution

Do not tighten the top cone race too tight to prevent from damage the ball bearing seat when tightening the top cone race.

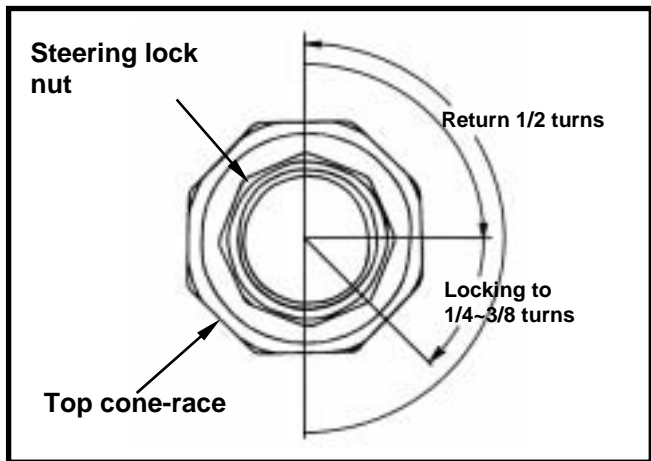

Install the steering lock nut and lock the top cone race. Then, tighten the nut.

Torque value: 1.0~2.0 kgf-m

Install the bearing seat according to the reverse procedure of removal.

⚠ Caution

Check the steering column if it can be turned freely and no clearance in vertical motion.

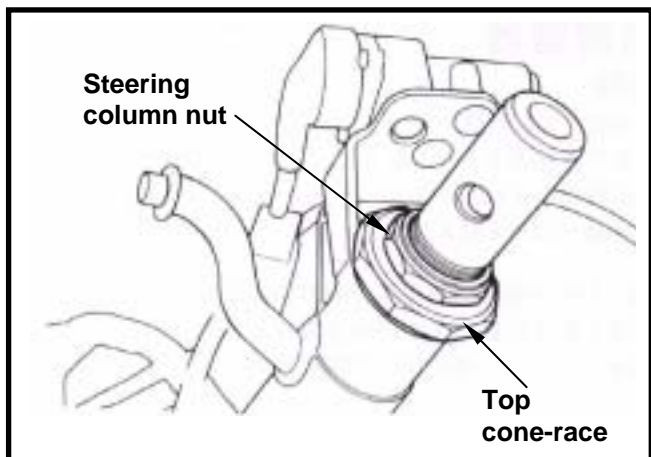

15. Rear Wheel/Rear Fork/ Rear Shock Absorber

Mechanism Illustration.....	15-1	Rear Wheel	15-3
Precautions in Operation	15-2	Rear Carrier	15-4
Trouble Diagnosis	15-2	Rear Shock Absorber	15-6
Exhaust Pipe	15-3		

Mechanism Illustration

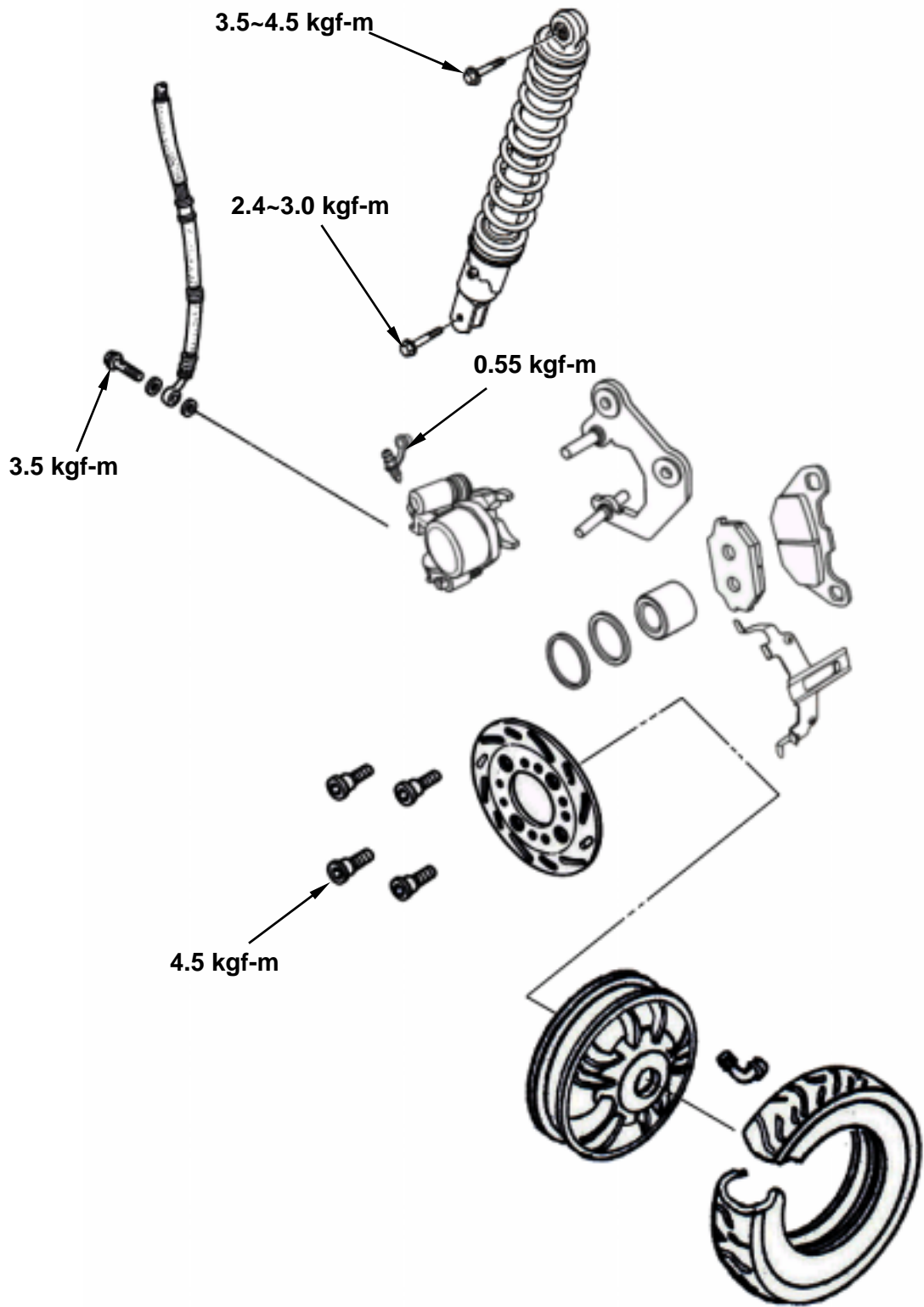

15. Rear Wheel/Rear Fork/ Rear Shock Absorber

Precautions in Operation

General Information

As for the wheel removal, service, and installation procedures, please refer to the service manual of high speed tire.

Specification

Unit: mm

Items		Standard	Limit
Wheel wobbling	Radial	-	2.0
	Axial	-	2.0
Thickness of rear brake lining		4.0	2.0
Free length of rear shock absorber		238.6	233.6

Torque values

Rear axle nut	10.0~12.0 kgf-m
Rear brake caliper bolt	2.9~3.5 kgf-m
Rear shock absorber upper mount bolt	3.5~4.5 kgf-m
Rear shock absorber lower mount bolt	2.4~3.0 kgf-m
Exhaust pipe connection nut	1.0~1.2 kgf-m
Exhaust pipe connection bolt	3.2~3.8 kgf-m

Trouble Diagnosis

Rear wheel wobbling

- bend wheel rim
- poor tire
- loosen wheel shaft

Shock absorber too soft

- insufficient shock absorber spring force

Braking Noise

- worn brake lining
- brake drum deformation
- improperly brake panel installation
- unparalleled brake drum or wheel unparallel.

Poor brake performance

- Poor brake adjustment
- contaminated brake lining
- worn brake lining
- Air inside of the brake hose/pipe
- greased brake disc
- Clogged brake pipe
- Bent brake pipe
- Insufficient brake fluid

Exhaust Muffler

Removal

Remove the front-end nut of the exhaust muffler. (nut x 2)
 Remove the bolts. (bolts x 3)
 Remove the exhaust muffler.

Installation

Install the exhaust muffler according to the reverse procedure of removal.

Caution

Replace the exhaust muffler gasket if it is broken or deformed.

Torque value:

Exhaust muffler connection bolt: 3.2~3.8 kgf-m
 Exhaust muffler connection nut: 1.0~1.2 kgf-m

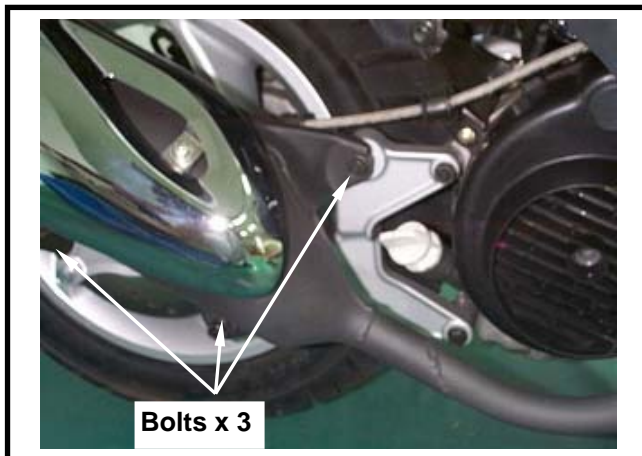
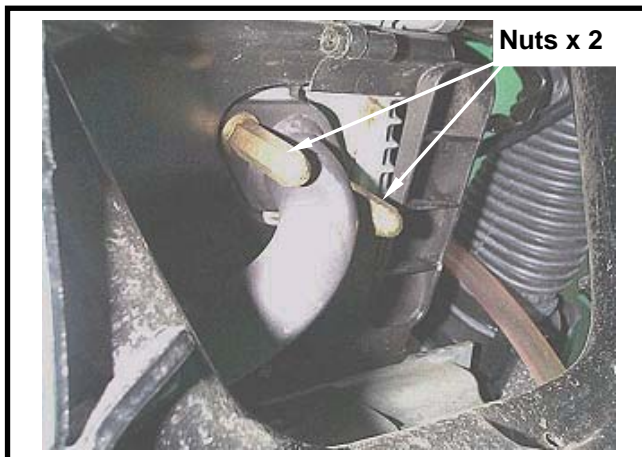

Rear Wheel

INSPECTION

Measure wheel rim wobbling.

Service limit:

Radial: 2.0 mm

Axial: 2.0 mm

- If the wheel rim wobbling out of the specification, except resulted from the wheel rim deformation, it might be loosen or worn final driving shaft bearing or bend, deformed driving shaft.

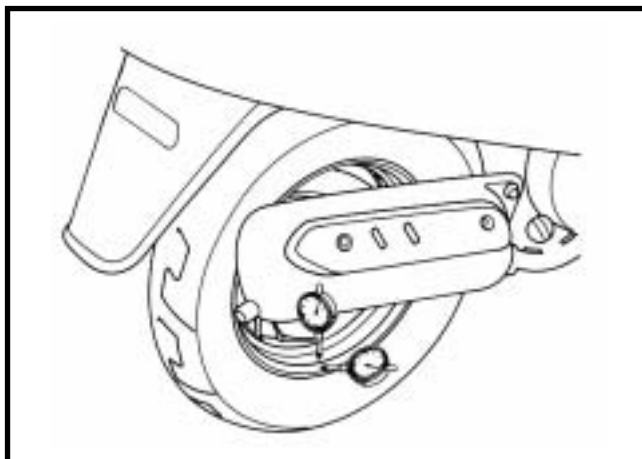

Removal

Remove the rear brake pipe mounting seat. (bolt x 2)

Remove the rear brake assembly. (bolt x 2)

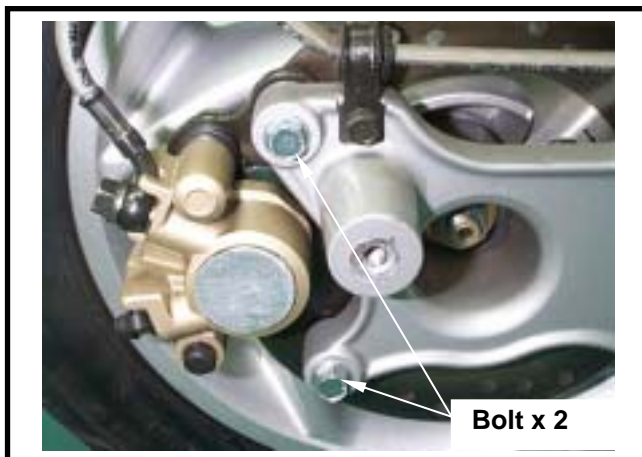

15. Rear Wheel/Rear Fork/ Rear Shock Absorber

Remove the front bolt from the rear carrier.
 (bolt x 2)
 Remove the rear wheel axle nut. (nut x 1)

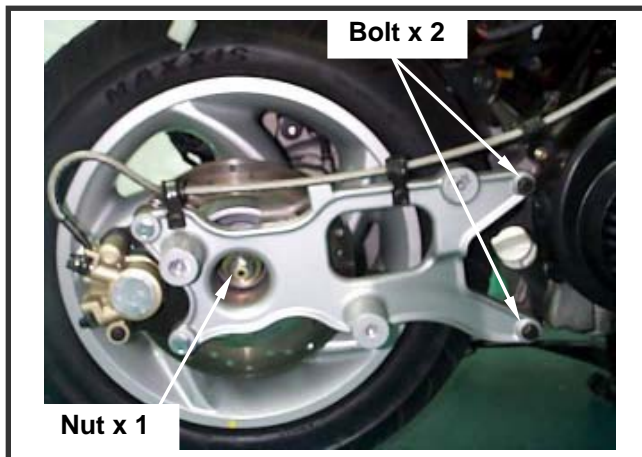

Remove the rear fork.



Remove the rear wheel.

⚠ Caution

Never hold the brake lever as caliper was removed so that prevent from pushing out the brake pad.



Rear Fork

Bearing

Turn the inner ring of bearing onto the fork with hand. The bearing should be turned smoothly & quietly.
 Check the match condition of both bearing and arm.
 Replace it if turning is not smooth or in noisy.

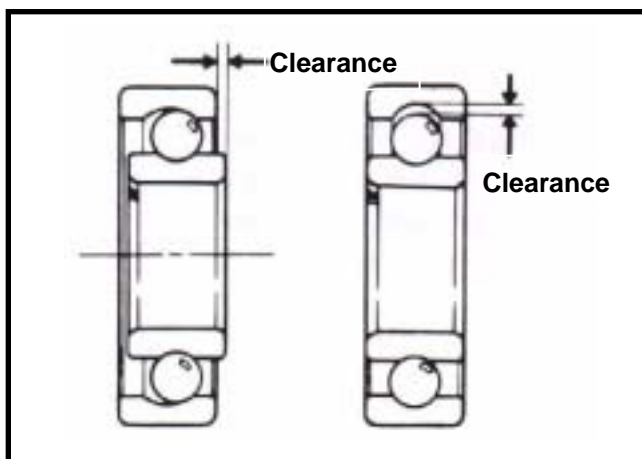



15. Rear Wheel/Rear Fork/ Rear Shock Absorber

Replacement of Rear Wheel Bearing

Remove the outer bearing from the fork.
 With inner type bearing puller to remove bearing.
 Remove inner oil seal.

⚠ Caution

Do not use the used oil seal.

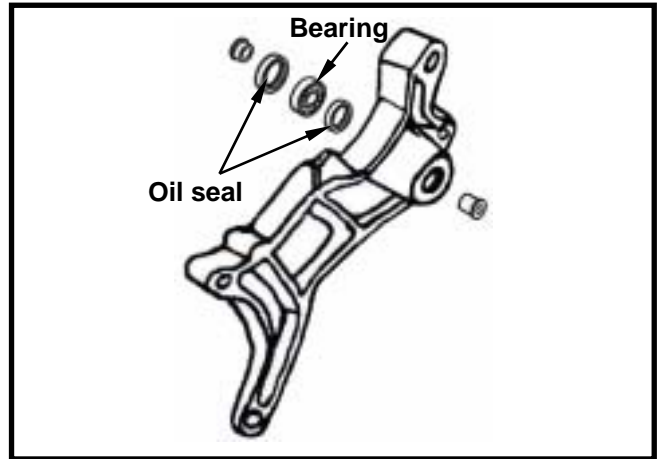

Install a new bearing onto the fork with C-press or bearing presser.
 Install oil seal and bearing bushing onto the fork.



Installation

Install rear wheel.
 Install bearing bushing onto the fork.
 Install the fork onto the rear wheel axle.
 Install the bearing bushing and washer onto the fork.
 Tighten the rear wheel axle nut.
 Install the brake caliper, and then tighten caliper bolt & pipe mounting bracket.
 Install the exhaust pipe, and then tighten its bolt and nut.
 Install body covers according to the reverse procedure of removal.

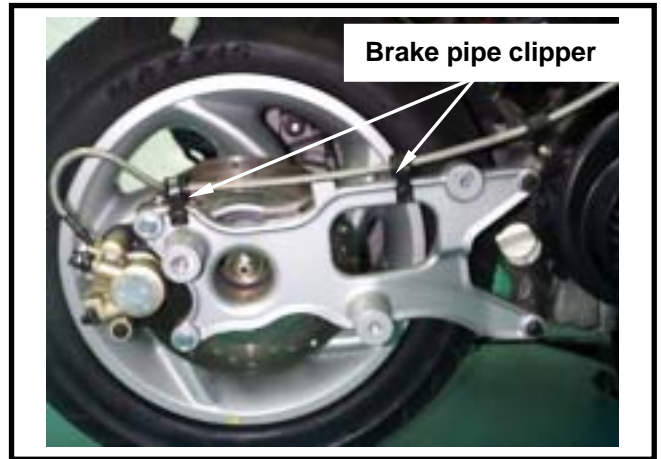

Torque value:

Rear axle nut	10.0~12.0 kgf-m
Rear brake caliper bolt	2.9~3.5 kgf-m
Exhaust pipe connection bolt	3.2~3.8 kgf-m
Exhaust pipe connection nut	1.0~1.2 kgf-m

⚠ Caution

Pay attention to on the installation direction of the rear carrier axle ring. The small end of inner & outer axle rings have to forward to arm bearing.

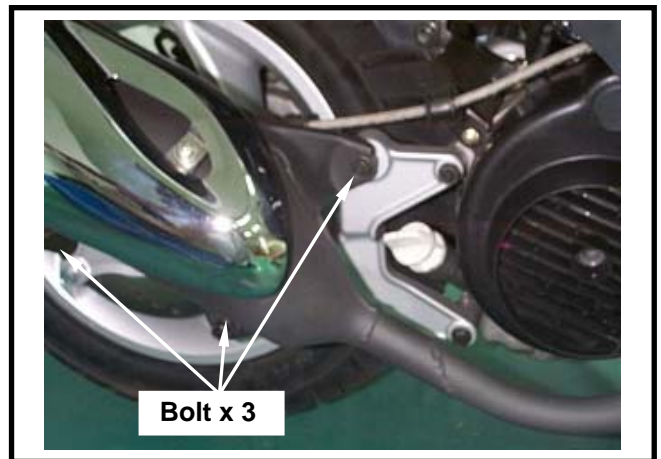

15. Rear Wheel/Rear Fork/ Rear Shock Absorber

Rear Shock Absorber

Removal

Remove the luggage box. (bolt x4, screw x1)

Remove the body cover. (screw x 4)

Remove the air cleaner. (bolt x2)



Remove the under bolt of the rear shock absorber. (bolt x 1)



Remove the upper bolt of the rear shock absorber. (bolt x 1)

Remove the rear shock absorber.

Installation

Install the rear shock absorber according to the reverse procedure of removal.

Caution

The rear shock absorber has to be replaced with one set and can not be replaced by unauthorized persons. Otherwise, it might damage the rubber bushing and construction.



Torque values

Rear shock absorber lower mount bolt:

2.4~3.0 kgf-m

Rear shock absorber upper mount bolt:

3.5~4.5 kgf-m

Precautions In Operation 16-1	Starting System 16-9
Trouble diagnosis 16-2	Meter 16-11
Battery 16-2	Lamp/Bulb 16-13
Charging system 16-3	Main switch/Horn 16-15
Current Leakage Test 16-4	Fuel Pump 16-18
Ignition System 16-7	

Precautions In Operation

- When remove the battery, the disconnection sequence of cable terminals shall be strictly observed.
- Spark plug heat range/model and tighten torque.
- Ignition plug.
- Headlamp adjustment.
- Removal and installation of alternator.
- MF (Maintenance Free) battery does not need to check, add electrolyte or distilled water.
- Battery must be taken out from scooter when charging the battery. But do not open the battery caps.
- Do not quick charge the battery unless in emergency.
- A voltmeter must be used when checking battery charging condition.
- Starting motor can be removed directly from engine.

Specification

Charging System

Items		Specification
Battery	Capacity	12V8Ah
	Charging rate	STD: 0.16A/5hrs, emergency charging: 16A/0.5hrs
Leaking current		Less 1mA
Charging current		4.8A/1600 rpm
Voltage controlled by regulator		14.5±0.5V/2000 rpm

16. Electrical Equipment

Trouble diagnosis

No power supply

- Dead battery
- Disconnect battery cable
- Fuse burned out
- Faulty ignition switch

Low voltage

- Weak battery
- Loose battery connection
- Charging system failure
- Voltage-current regulator failure

Starter motor does not work

- The fuse is blown
- The battery is not fully charge
- Poor main switch
- Poor starter switch
- The front and rear brake switches do not operate correctly
- Starter relay is out of work
- The ignition coil is poorly connected, open or short-circuited
- The starter motor is out of work

Intermittent power supply

- Loose charging system connection
- Loose battery cables
- Loose connection or short-circuit in discharging system
- Loose connection or short-circuit in lighting system

Charging system failure

- burn Fuse
- Loose, broken or shorted wire or wire connection
- Faulty voltage regulator
- Faulty alternator

Weak starter motor

- Poor charging system
- The battery is not fully charged
- Poor connection in the windings
- The motor gear is jammed by foreign material

Starter motor is working, but engine does not crank

- Poor starter motor pinion
- The starter motor run in reverse direction
- Poor battery

Battery

Removal

Remove the rubber carpet.

Remove the battery cap. (screw x 3)

Remove the battery mounting bracket. (bolt x 2)

Firstly, remove the negative(-) post, and remove the positive (+) post.

Remove the battery.

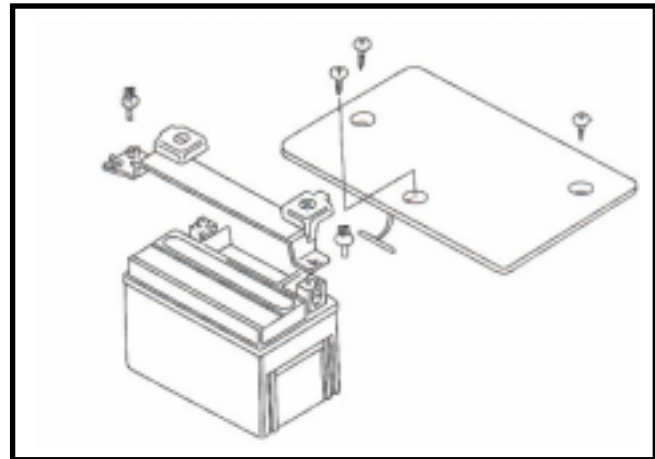

Voltage Inspection

Measure the voltage with a digital voltage meter.

Voltage Value:

Fully charged: 13.0~13.2V at 20

undercharged: less 12.3V at 20

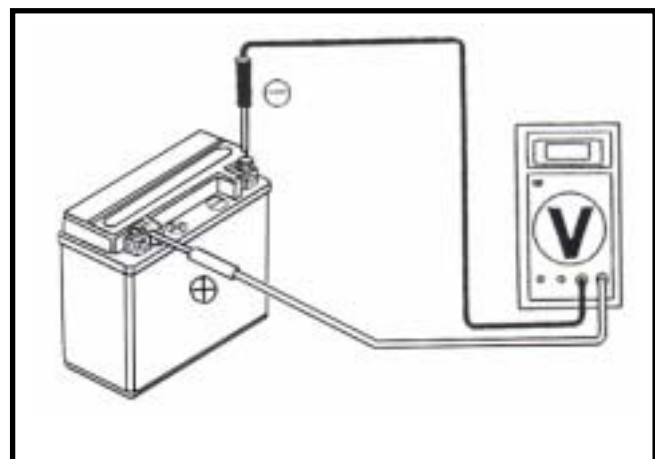

Charging system

Charging wire circuit

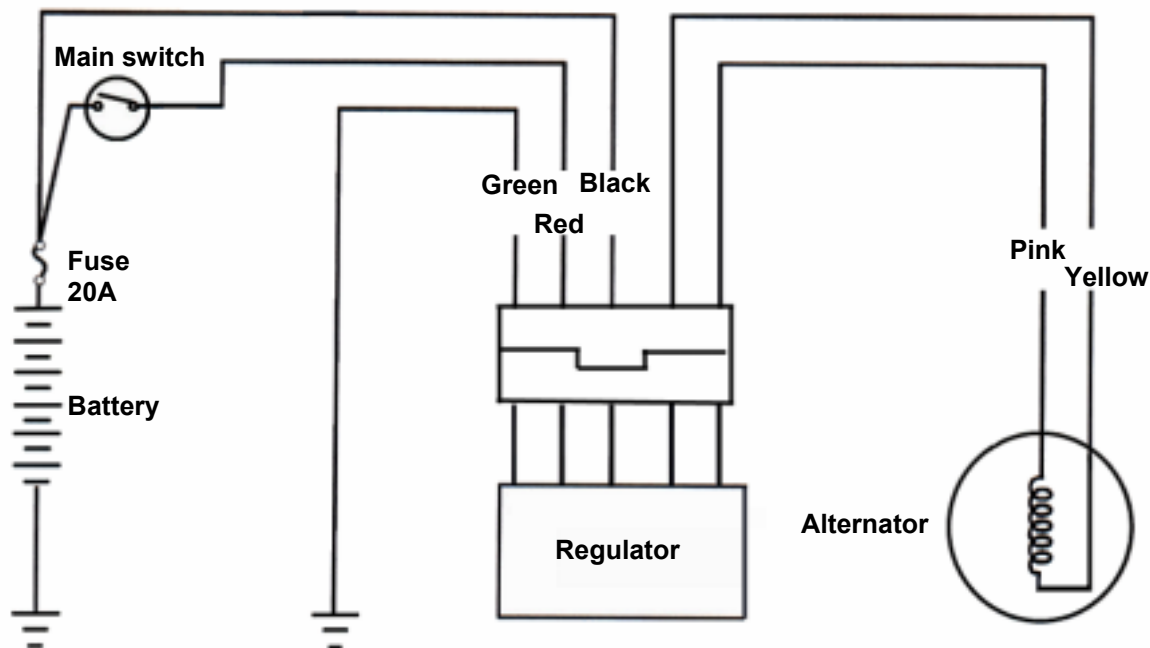

Charging

Connect the battery charger's positive (+) terminal to battery's positive (+) post.
 Connect the battery charger's negative (-) terminal to battery's negative (-) post.

	Standard	Max
Charging current	0.9A	16.0A
Charging time	5~10H	1H

Warning

Strictly keep flames away from a charging battery.
 The charging ON/OFF is controlled by the charger's switch. Do not control the charging by battery jump wires.

Caution

Quick charge a battery should be used only in an emergency.
 Make sure the current and charging time of above description.
 The battery will be damaged by too much current or too rush charging.

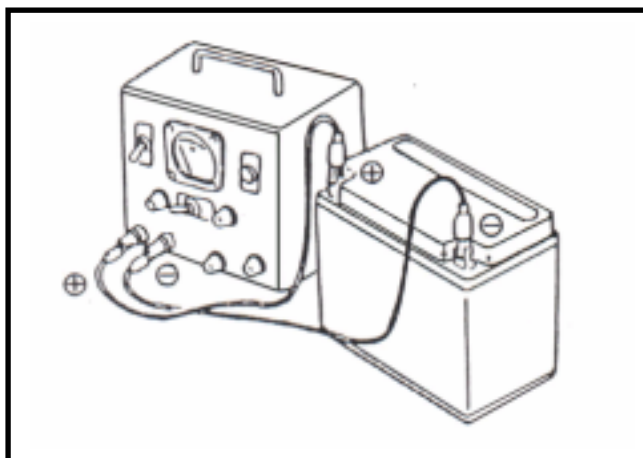

After installing the battery, coat the terminals with clean grease.

16. Electrical Equipment

Current Leakage Test

Current Leakage Inspection

Turn the main switch to OFF position, and remove the negative cable terminal (-) from the battery.

Connect an ammeter between the negative cable terminal and the battery negative terminal (as shown on left diagram).

Caution

- In the current leakage test, set the current range at larger scale, then gradually decrease to the lower scale as the test process goes to avoid possible damage to the ammeter and the fuse.
- Do not turn the main switch to ON position during test.

If the leaked current exceeds the specified value, it may indicate a short circuit.

Allowable current leakage: Less than 1 mA

Disconnect each cable one by one and take measurement of the current of each cable to locate the short circuit.

Charging Voltage/Current Inspection

Caution

- Before conducting the inspection, be sure that the battery is fully charged. Use a fully charged battery having a voltage larger than 13.0 V. If undercharged, the current changes dramatically.
- While starting the engine, the starter motor draws large amount of current from the battery. Thus, do not start the engine with battery.

After the engine is warmed up, replace original battery with a fully charged battery.

Connect a digital voltmeter to the battery terminals.

Connect an ammeter between both ends of the main fuse.

Caution

When the probe is reversibly connected, use a voltmeter having an indication that the current flows from the positive or the negative direction and the measurement should be at zero, ammeter at one direction only.

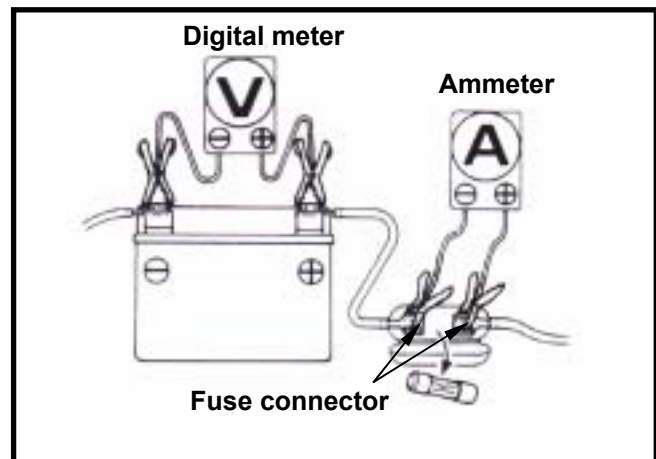
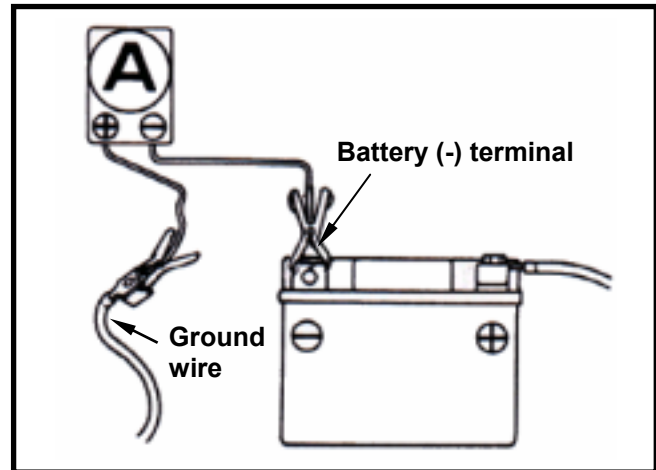

⚠ Caution

- Do not use short-circuit cable.
- It is possible to measure the current by connecting an ammeter between the battery positive terminal and the cable position terminal, however, while the starter motor is activated, the surge current of the motor draws from the battery may damage the ammeter. Use the foot lever to start the engine.
- The main switch shall be turned to OFF position during the process of inspection. Never tamper with the ammeter and the cable while there is current flowing through. It may damage the ammeter.

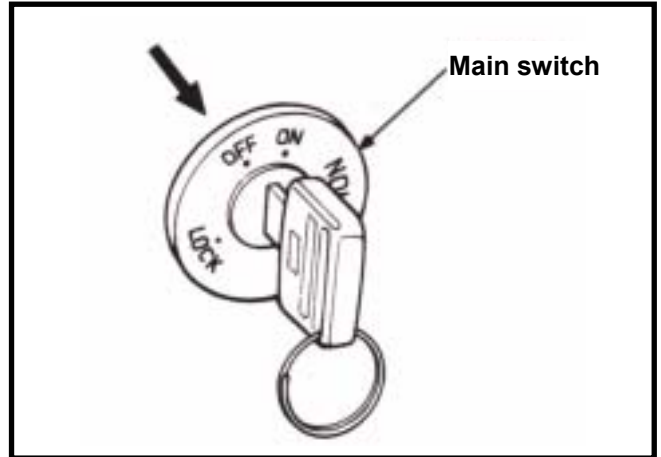

Connect DATDSCAN, and switch to data analysis menu.
 Turn on the headlamp to high beam and start the engine.
 Accelerate the engine gradually to the specified revolution per minute and measure the charging voltage/current.

Charging Current: 4.8A/1600 rpm

**Control Charging Voltage:
 14.0±0.5 V / 2000 rpm**



⚠ Caution

To replace the old battery, use a new battery with the same current and voltage.

The following problems are related to the charging system, follow the instructions provided in the checking list to correct it if any one of the problems takes place.

- (1) The charging voltage can not exceed the voltage between two battery terminals and the charging current is in the discharging direction.
- (2) The charging voltage and current are too much higher than the standard values.

The following problems are not related to the charging system; correct it if any by following steps indicate in the checking list.

- (1) The standard charging voltage and current can only reach when the revolution of the engine exceeds the specified rpm.
 - Bulbs used exceed their rate and consume too much power.
 - The replacement battery is aged and does not have enough capacity.
- (2) The charging voltage is normal, but the current is not.
 - The replacement battery is aged and does not have enough capacity.
 - Battery used do not have enough electricity or is over charged.
 - The fuse of the ammeter is blown.
 - The ammeter is improperly connected.
- (3) The charging current is normal, but the voltage is not.
 - The fuse of the voltmeter is blown.



16. Electrical Equipment

REGULATOR INSPECTION

Remove the rear carrier. (refer to chapter 12, section 8)

Remove the body cover. (refer to chapter 12, section 8)

Disconnect the 3P connector of the regulator.

Item	Measurement point	Standard Value
Main switch connection wire	R~B	Battery voltage (ON)
Battery connection wire	R~G	Battery voltage

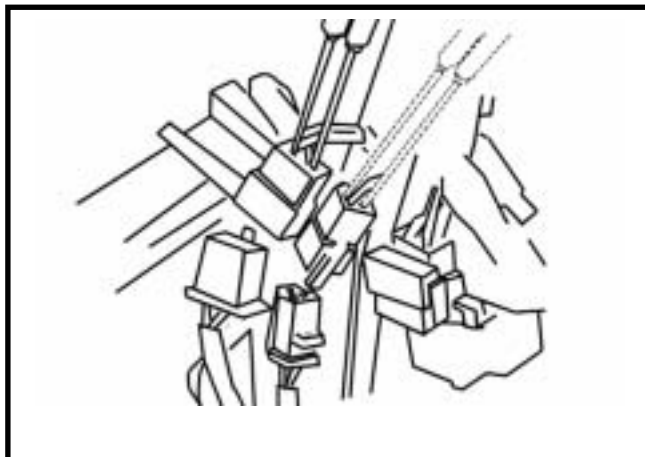

Check the parts onto the abnormal wire circuit if the measured values are not within standards. If the parts is OK, then it is the wire circuit abnormal.

Replace the regulator if both checks are OK.

CHARGING COIL INSPECTION

Caution

The coil need not be removed from engine as conduct this test.



At the alternator side from the regulator connector, measure the resistor between pink and yellow wires.

Standard value: 0.16~0.8Ω

Ignition System

Ignition System Circuit

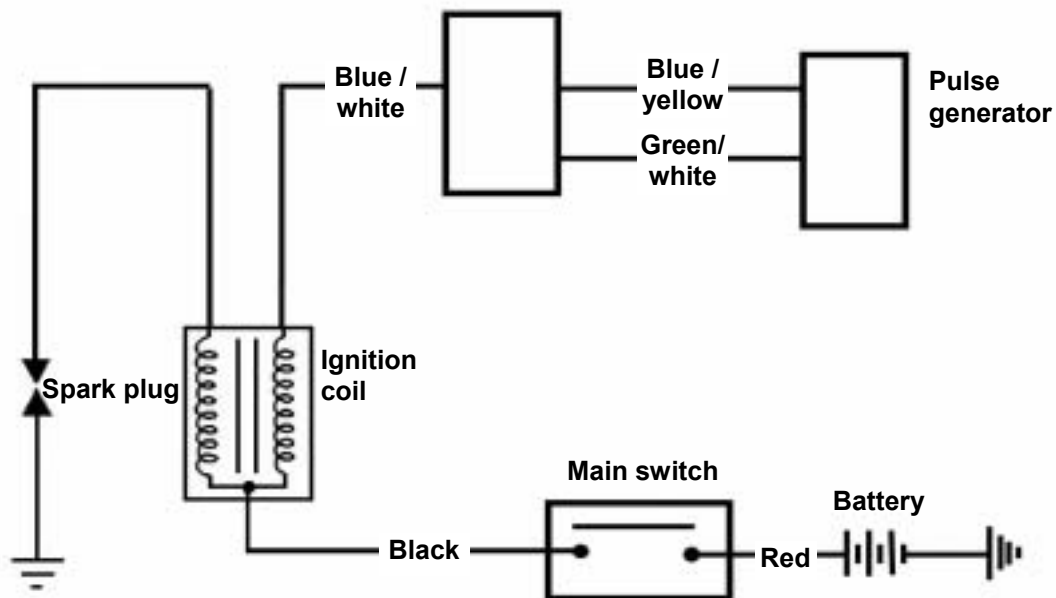

Make the following inspection at each terminal of the harness side connector.

ITEM		Measure at:	result
Crank position sensor		Green / white- blue / yellow	$120 \pm 10\% \Omega$
Ignition Coil	Primary	Black / white-red	0.63Ω
	Secondary	Black / white- high voltage cable	$2.9M\Omega$

Ignition coil

Remove the luggage box.
 Remove the ignition coil connector and the spark plug cap.
 Measure the resistor between the terminals of ignition coil primary circuit.

Standard value: 0.63Ω

Remove the spark plug cap from the spark plug wire, and measure the resistor between the spark plug wire and primary circuit terminal (black/white).

Standard value: without cap $2.95 M\Omega$

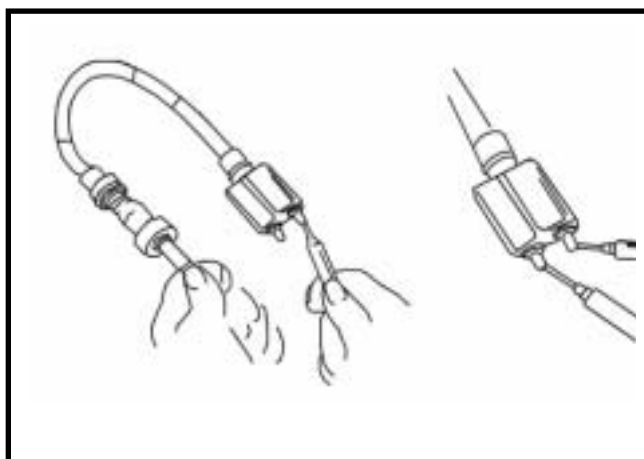

16. Electrical Equipment

Replacement

Remove the mounting bolt of ignition coil if necessary, and replace the ignition coil.

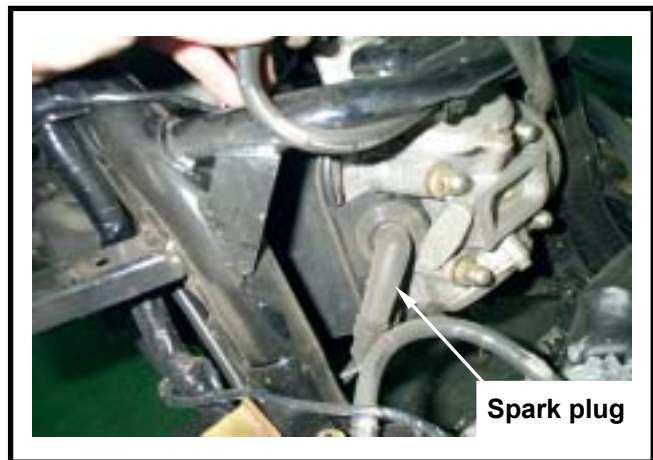

CRANK POSITION SENSOR INSPECTION

Disconnect the pulse generator connector, measure the resistor between terminals from green/white to blue/yellow wires.

Standard value: $120 \pm 10\% \Omega$

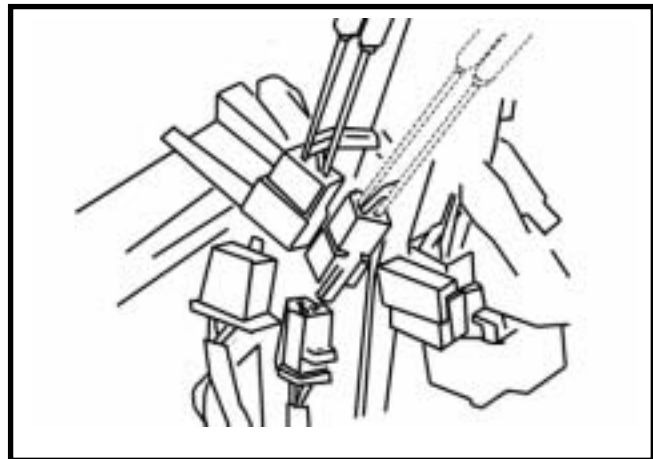

Starting System

Starting Circuit

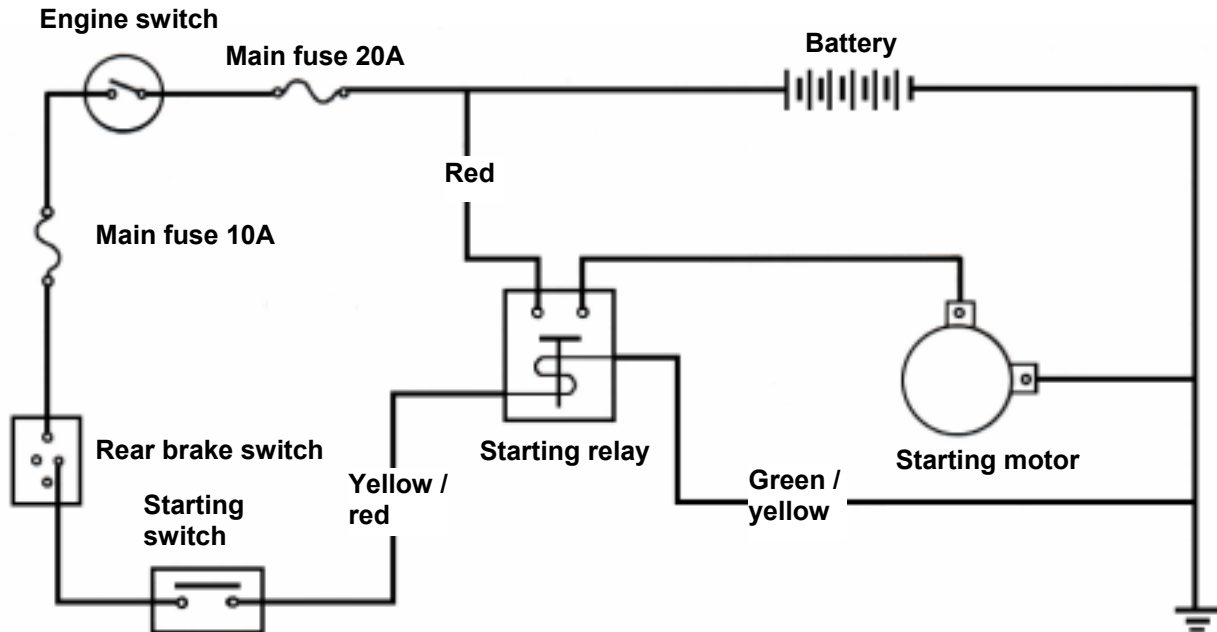

Starting Relay Inspection

Turn main switch to "on", and operate the brake lever. Then press starting button to check if there is a click sound. It is normal if there is a click sound.

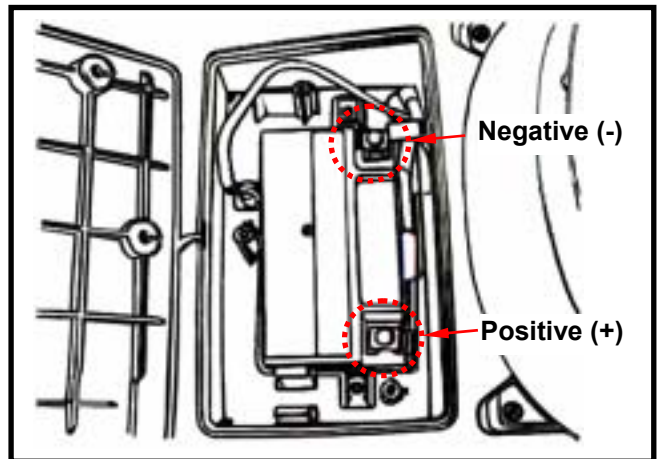

Remove the luggage assembly.
 Disconnect the battery negative (-) terminal.
 Remove the battery positive (+) connection and starting motor wires from the starting relay large pin.
 Remove the power control connector of the starting relay.
 Connect a Ohmmeter between the starting relay large pins.
 Connect the green/yellow wire to battery positive (+) terminal, and the green/yellow wire to battery negative (-) terminal.
 Check the continuity between the starting relay large pins.
 If it is not continuity, then replace the starting relay.



16. Electrical Equipment

STARTING MOTOR REMOVAL

Remove the luggage. (chapter 12, section 6)



Remove the air cleaner. (chapter 4, section 10)



Remove the battery negative terminal.
Remove the battery positive terminal and the starting motor wire from the big terminal of starting relay.
Remove the starting motor mounting bolts and the motor.



Remove the starting motor mounting bolts and the motor.



Starting Motor Installation

Install the motor and other components in reverse procedure of removal.

Meter

Removal

Remove the front cover. (chapter 12, section 4)



Remove the power connector of the instrument panel.



Remove the rear cover of the handlebar. (chapter 12, section 3)
Remove the odometer cable.



Remove the turn signal lamp relay.



16. Electrical Equipment

Remove the front cover of handlebar. (chapter 12, section 3)



Remove the instrument panel assembly. (screw x 4)

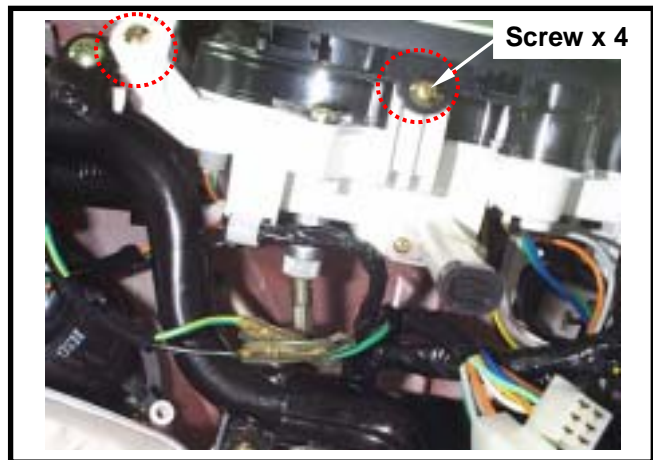

Disassemble the instrument seat and the instrument. (screw x 2)

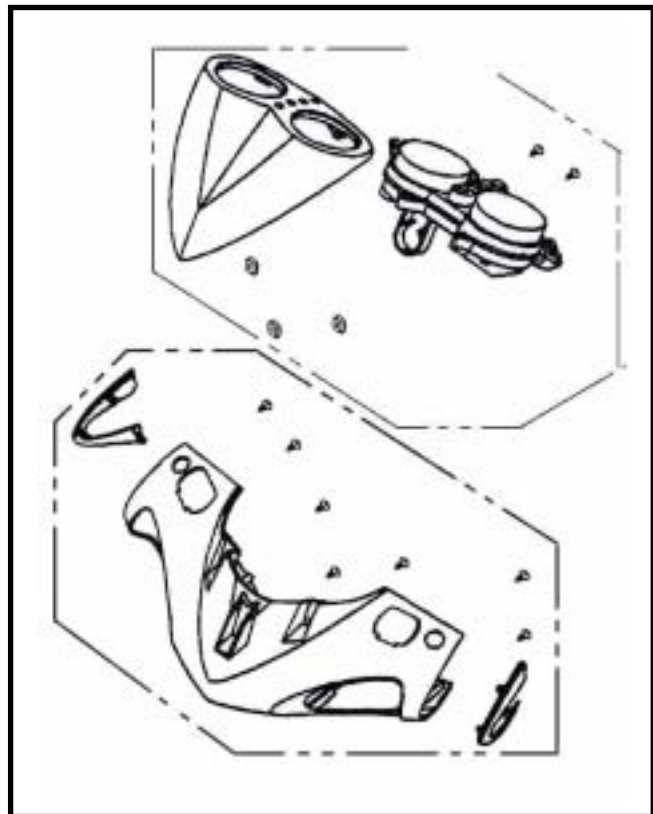

Instrument Panel Installation

Install the panel in reverse procedure of removal.



Lamp/Bulb

Headlamp Bulb Replacement

Remove the front fender. (chapter 12, section 4)
Disconnect the headlamp wire connector, and then remove the rubber boot.

Press down the bulb spring locker and then remove the locker with turning it in CCW motion.
Replace the bulb with new one if necessary.

 **Caution**

- Do not touch the bulb surface with fingers because the bulb will create hot-spot so that let it be burnt. It has to be package with cloth or wear glove as installing.
- Wipe the bulb with cloth to prevent from damaged if the bulb be touched by hands.

Install the bulb in reverse order of removal.
Connect power to check if the bulb has been installed properly after installation.
Please conduct the headlamp beam adjustment job if replace the headlamp bulb.

Front Turn Signal Lamp Bulb Replacement

Remove the lamp cover of the turn signal lamp. (screw x 2)

Replace the bulb with new one.



16. Electrical Equipment

Rear Turning Signal Lamp Replacement

Pry out the lamp cover from the preset slot onto the lower parts of cover.
Check if the bulb is burnt or damage, and replace it if necessary.
Connect power to check if the bulb has been installed properly after installation.

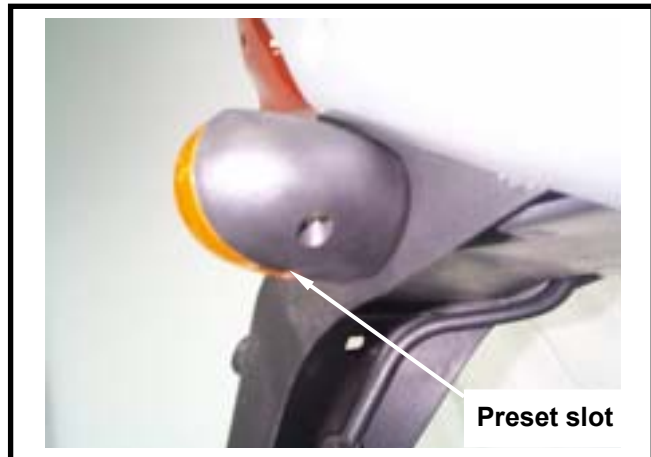

Tail Lamp/Brake Lamp Replacement

Remove the outer cover of the tail & rear turning signal lamps. (screw x 2)
Check if the bulb is burnt or damage, and replace it if necessary.
Connect power to check if the bulb has been installed properly after installation.



Main switch/Horn

Main Switch

Inspection

Remove front fender. (chapter 12, section 4)
 Disconnect main switch leads connector.
 Check connector terminals for continuity.

	BAT1	BAT2
LOCK		
OFF		
ON	—————	
Wire color	Red	Black

Replacement

Remove the handlebar bolt. (bolt x 1)



Remove the handlebar assembly.



Remove the main switch connector and bolts.
 (bolts x 3)
 Remove the main switch.
 Install a new main switch and tighten the bolts.
 (bolts x 3)

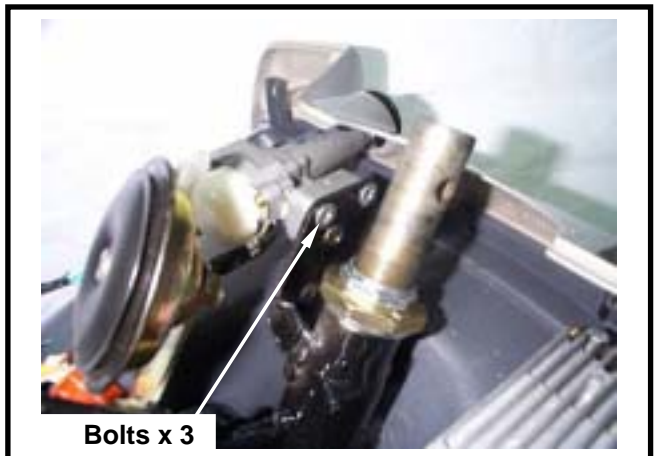

16. Electrical Equipment

Handlebar switch

Remove the rear handlebar cover. (chapter 12, section 3)

Disconnect the connector of the handlebar switch.



Check the continuity of follow pins listed below columns.

Starting switch

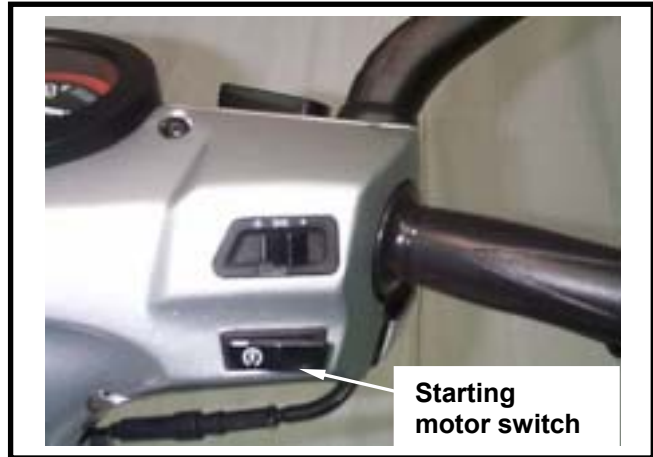
	ST	E
FREE		
	—	—
Wire color	Yellow/ Red	Green





Headlamp switch

	CI	TL	HL
	—	—	
	—	—	—
Wire color	Black	brown	Brown/ white



High/Low beam switch

	LO	HL	HI	PASS
		—		
	—			
PASSING	—	—	—	—
Wire color	White	Brown/ white	Blue	Black

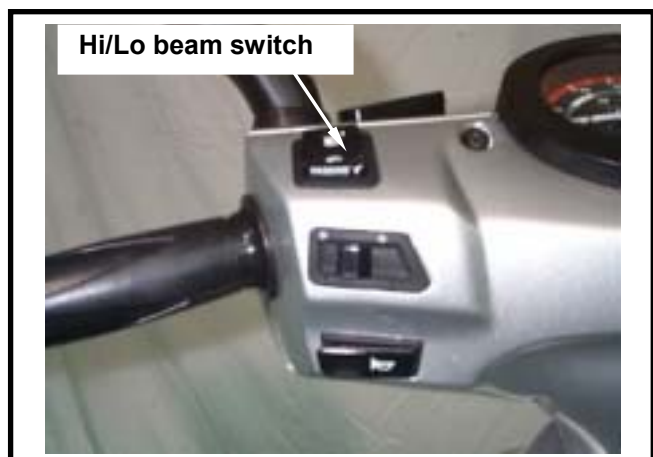



Turn signal lamp switch

		R	WR	L
N	FROM R			
	PUSH OFF			
	FROM L			
Wire color		Light blue	Gray	Orange

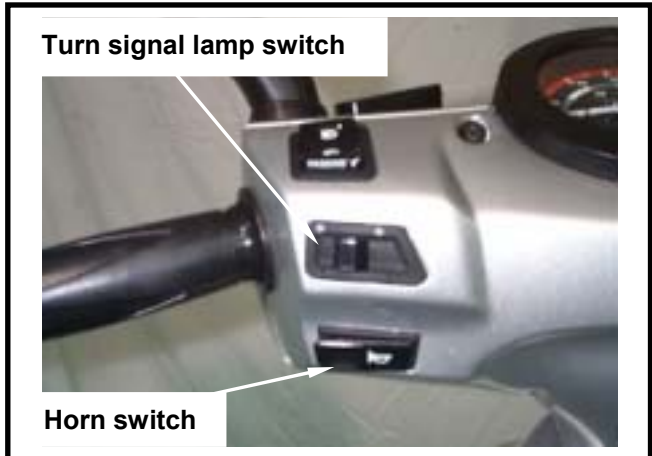

Horn

Remove the front fender.
 Connect 12V power to the 2 pins on the horn.
 Then, the horn should sound.
 Replace it if necessary.

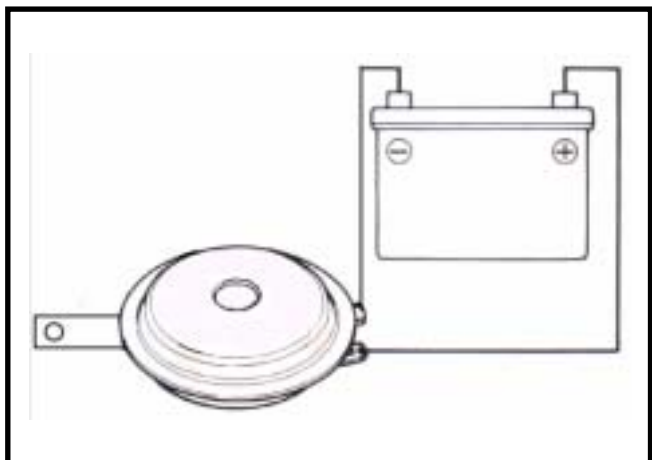

Brake lamp switch

The circuit of black wire and the green/yellow wire on the brake lamp switch should be in continuity when operating the brake lever.
 If the switch damaged, replace it with new one.

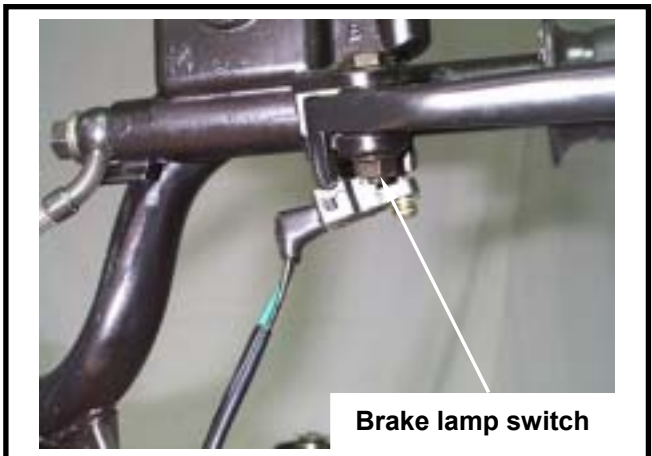

16. Electrical Equipment

Fuel Pump

Removal

- Open the seat cushion.
- Remove the luggage box assembly. (Chapter 12, section 6)
- Remove the rear carrier. (Chapter 12, section 8)
- Remove the left & right side body covers. (Chapter 12, section 8)

Disconnect the fuel pump and the wires & pipes around the filler opening. (screw x 4)



With special service tools to loosen the mounting plate by in CCW motion.
Take out the fuel pump.

⚠ Caution

Gasoline is a very low ignition point & high evaporative material. Thus, it is has to strictly prohibit flame or spark as operation. Gasoline or its evaporation is harmful to human skin so always avoid to contact with gasoline. Quickly clean or flush it if skin contacted.
Keep the clearness inside of the fuel tank and prevent from foreign materials falling into the tank.



⚠ Caution

Do not damage or bend the float arm as removing.



The resistance values are listed below when the float arm in F and E positions.

Float arm position	Resistance value
E (empty)	97.5~107.5 Ω
F (full)	4~10 Ω

Connect the fuel gauge sender to the main harness.

Turn the main switch "ON".

Move the float arm in UP & DOWN, and then check if the fuel gauge indication needle is in correct position.

⚠ Caution

Turn on the turn signal lamp to make sure battery is in good condition before this test.

Float arm position	Indicator needle
UP (full)	F (full)
DOWN (empty)	E (empty)

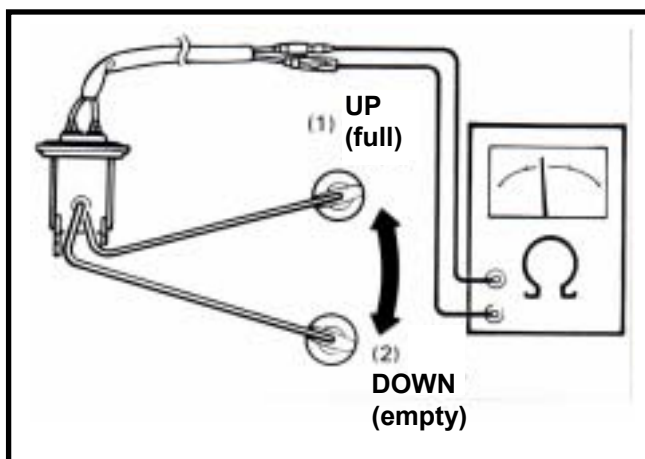

Periodical Maintenance Information/Emission Standard 17-1	Fuel Evaporative Emission Control System (E.E.C.)..... 17-3
Precautions for ensuring within emission standard 17-1	Crankcase blow-by system ... 17-5
Names Of Mechanisms In The Emission Control System 17-2	Ignition System 17-6
Function Of Mechanisms In The Emission Control System 17-2	Inspection Items 17-7
	Countermeasure For Emission Pollutants Not Within Standard As In Idle Speed (4-Stroke Engine)..... 17-8

Periodical Maintenance Information/Emission Standard

Please conduct periodical inspection, adjustment or service to ensure best performance in SYM authorized dealers or service centers.

Note 1: Clean or replace the air cleaner element more often when the motorcycle is operated on dusty roads or in the Heavily- polluted environment.

Note 2: Maintenance should be performed more often if the motorcycle is frequently operated in high speed and after the motorcycle has accumulated a higher mileage.

Precautions for ensuring within emission standard

1. Fuel usage: Limited to use unleaded gasoline.
2. Oil usage: Limited to use 4-stroke engine oil.
3. Perform the periodical maintenance in accordance with the periodical maintenance schedule. (refer to the periodical maintenance schedule)
4. Per the emission control system, strictly limited to be adjusted or replaced arbitrarily (such as spark plug usage, idle speed adjustment, ignition timing, as carburetor adjustment).
5. Cautions:
 - Since the malfunction of ignition, charging, and fuel systems are effected the catalytic converter very much, please have your motorcycle to SYM authorized dealers or service centers to conduct adjustment or service.

Thus, it has to replace parts with SYM genuine parts and conduct by SYM authorized dealers or service centers if the motorcycle needs to replace one of the emission control system parts.

17. Emission Control System

Names Of Mechanisms In The Emission Control System

Four-Stroke engine model:

1. Catalyst converter (C.A.T.A.→Catalyst Converter)
2. Evaporative Emission Control System (E.E.C. → Evaporative Emission Control System)
3. Positive Crankcase Ventilation System (P.C.V. → Positive Crankcase Ventilation System)

Function Of Mechanisms In The Emission Control System

General:

The emission control strategy of this model was formulated basing on a four-stroke & 4-valve SOHC electronic controlled single cylinder engine. It adopts a charcoal canister to absorb the fuel vapor generated through evaporation in the fuel system. Then, introducing vapor into combustion chamber.

Electronic Fuel Injection Device:

This device consists of both the fuel supply system --- fuel tank, electrical fuel pump, fuel filter, and fuel pump regulator as well and the fuel control system --- fuel injector and ECU.

Fuel is delivered to the fuel injector onto the intake manifold through fuel tank to fuel pump. Fuel pressure is kept within 2.5 kg/cm² by means of the fuel regulator. Then, the injection signal from ECU is to let fuel inject to cylinder in every crankshaft rotation. In addition, the residual fuel is back to fuel tank by the fuel regulator.

The fuel pump is stalled into the fuel tank so that can reduce noise and simplify the fuel pipe routing. The electronic controlled ignition & injection system can control fuel consumption & emission efficiently so that reaches to the purpose of environmental purification.

Engine refinements:

Four Valves designed combustion chamber, together with optimum compression ratio, ignition timing, intake and exhaust timing, have all contributed to maximize the intake/exhaust efficiency and combustion efficiency.

Secondary air introducing system:

System	Device	Components	Purpose & function
Combustion system	Combustion chamber	4-valve combustion chamber	The semi-circular combustion chamber is designed to balancing the air stream to achieve the combustion stability.
EEC system	Evaporative emission control system	Charcoal canister Purge control valve	A canister is used to absorb vapor from fuel tank and to introduce it into carburetor at an opportune timing.
PCV system	Crankcase blow-by introducing device	Vapor separator	To introduce blow-by into combustion chamber via a separator for burning then discharging.

Fuel Evaporative Emission Control System (E.E.C.)

1. Construction:

- Reduce HC to pollute air.
- To absorber fuel vapor and saving fuel consumption.

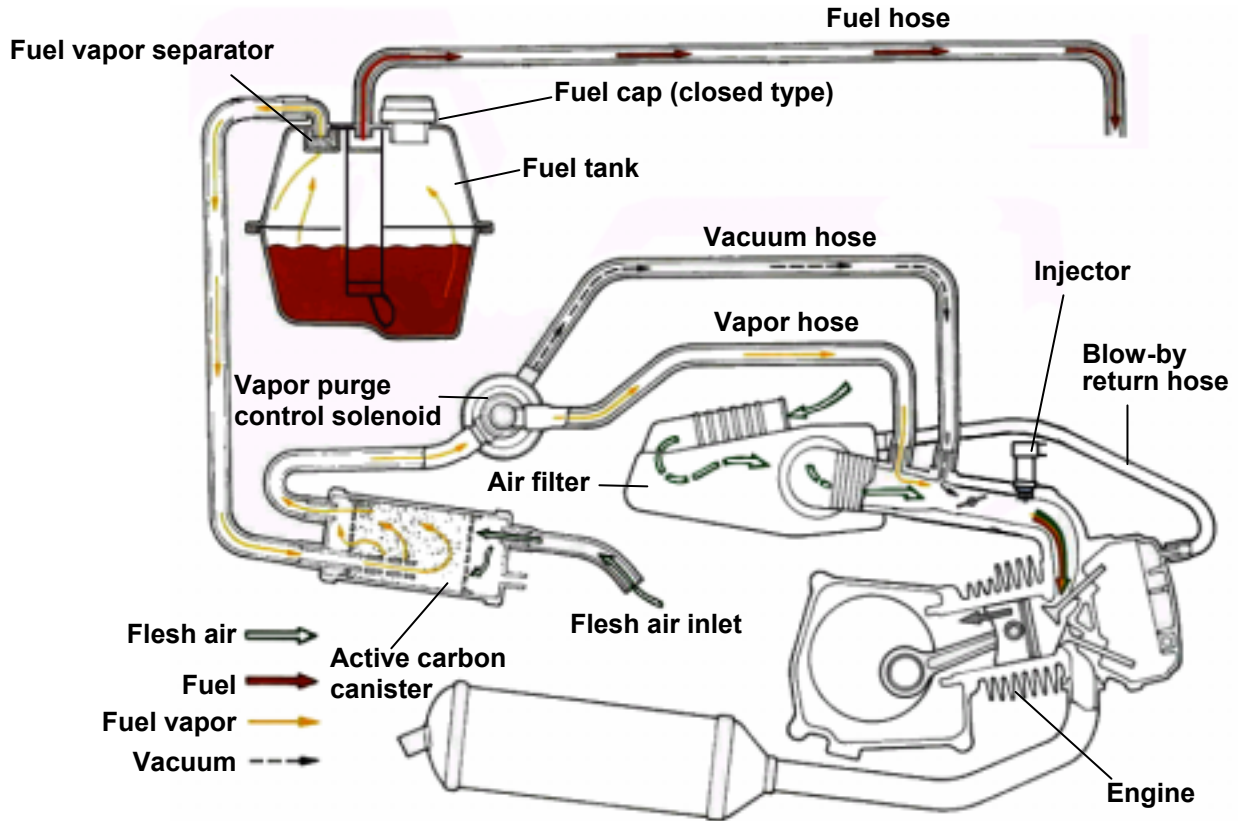

2. Principle of operation:

1. Vapor generated in fuel tank and fuel system through evaporation is contained in the confined system to prevent it from escaping into the atmosphere, at the same time, the vapor will be introduced into a charcoal canister where the hydrocarbon in the vapor will be absorbed by active carbon.
2. When engine is running, the negative pressure of intake opens the purge line, breaks HC off from active carbon and then sucks it into engine together with air from bottom of the canister.
3. The canister can be used repeatedly without reducing its performance because of the system's purge function.

3. Trouble Diagnosis:

Fuel can not flow to carburetor

1. No fuel in the fuel tank
2. loosen vacuum hose of the fuel pump
3. plugged hose in the system

4. Cautions:

1. Do not exceed the reed valve of the fuel filler when filling out fuel.
2. Do not have rush acceleration or running in high speed when applying the spare fuel.

17. Emission Control System

Service Methods for the E.E.C. system

1. Visual check:

- 1) Check the outside of canister for damage.
- 2) Check all hoses for breakage.

2. Leak test:

- 1) Disconnect the P.C.V. hose, and connect a T-type hose connector to a pressure gauge and a pressure source as shown below:

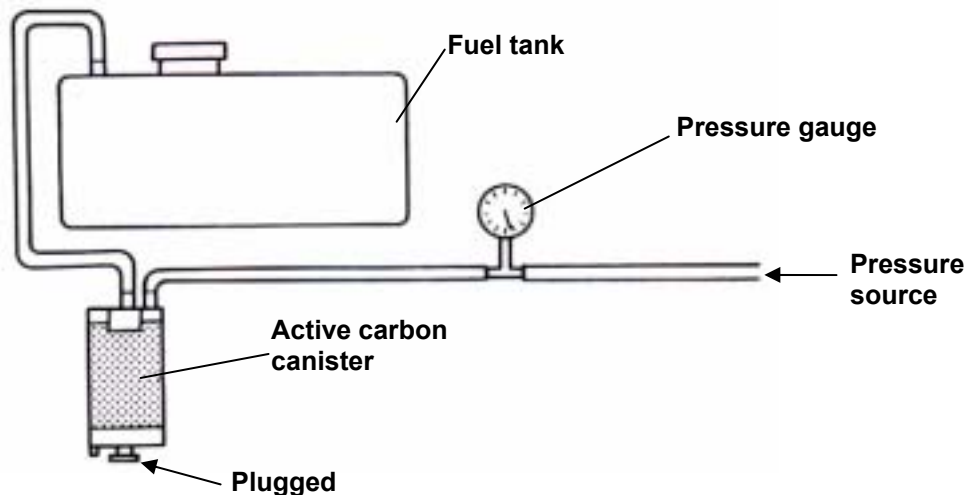

- 2) Plug canister vent.
- 3) Apply 100 mmAq into pressure source inlet then plug it. The pressure at the gauge should not drop to below 10 mmAq within 10 seconds.

3. P.C.V. Function Test:

- 1) Disconnect the hose of connection to the active carbon canister, and then connect a T-type hose connector to pressure source as shown below:

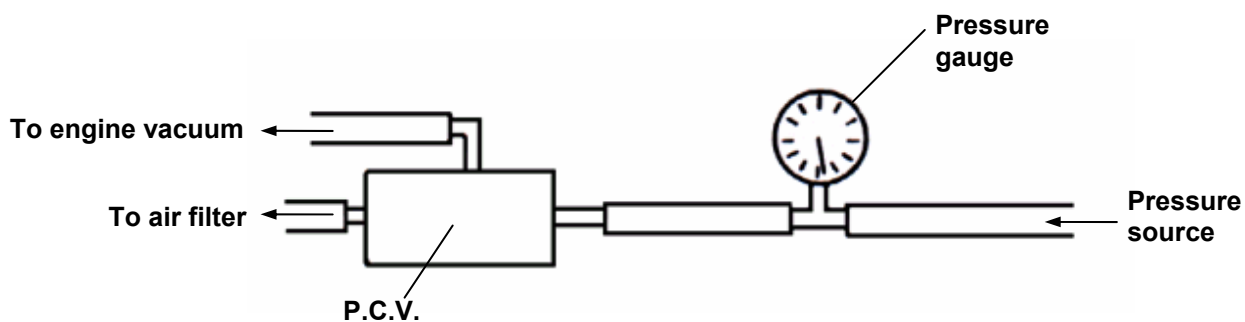

- 2) Apply 100 mmAq into pressure source inlet as engine stopped then plug it. The pressure at the gauge should not drop to below 10 mmAq within 10 seconds.

Crankcase blow-by system

1. Construction:

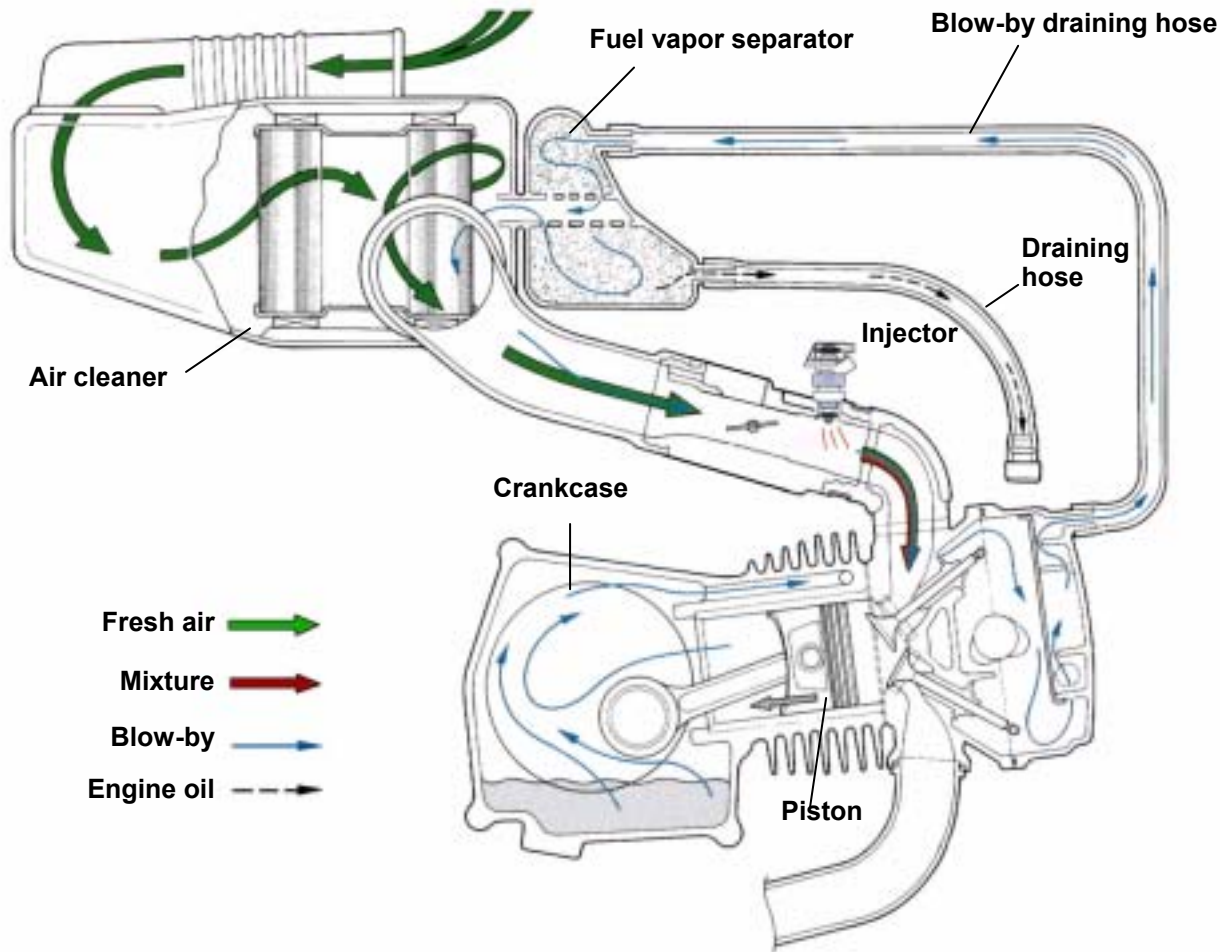

2. Principle of operation:

Install a separated chamber on cylinder head, and suck the blow-by gas to the fuel vapor separator by engine vacuum.
 Drill a hole in the air cleaner and install a vapor separator, so that blow-by from crankcase will flow through a cylinder check valve and then separated by the separator.
 The separated vapor will be sucked into combustion chamber by engine negative pressure to be burned again instead of discharging into atmosphere. Drain liquidized fuel in the drain pipe periodically.

3. Service Methods

Visual check

Remove drain plug to drain the fuel when fuel level on the drain pipe reaches 80 % full.
 Check connecting hose for damage and looseness.

17. Emission Control System

Ignition System

1. CONSTRUCTION:

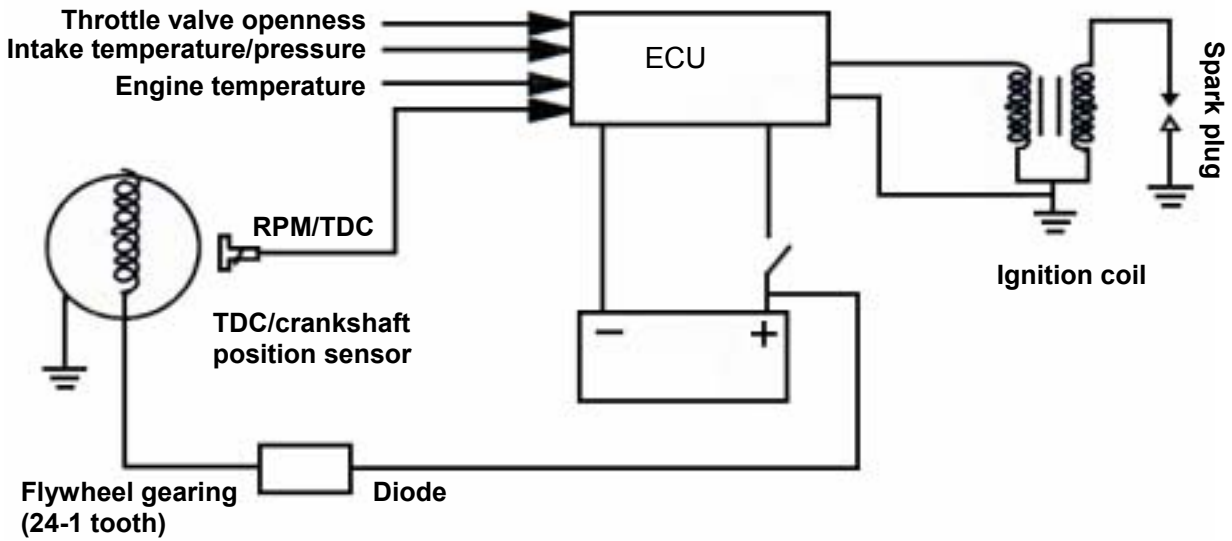

2. Principle of operation:

The engine is equipped with a computerized ignition control system that collects signals from TDC/crankshaft position sensor, throttle position sensor, temperature sensor, and intake temperature as well as pressure sensor. Then, correspondence with engine RPM, this 8-bit chip of ECU in the system is to control ignition timing properly. The secondary coil creates 25000~30000V high voltage to ignite the spark plug by means of the transistor to open/close operation of the primary current inside of the computerized system.

3. SPECIFICATION

- 1) Ignition timing: BTDC 13°/1600RPM
- 2) Spark plug: NGK CR8E
Gap: 0.7~0.8mm
- 3) A.C.G.
Pulse coil resistor: 120+10% Ω (G/W-Y)
- 4) Ignition coil
Primary circuit: 0.63 ± 0.03 Ω (20)
- 5) Battery
Type: TYX9A-BS.8Ah
Capacity: 12V 8Ah



Inspection Items

Fuel Evaporation Control System:

1. Visual inspect the carbon canister and hoses for damage.
2. leaking check.
3. function test of the purge control solenoid valve.

Crankcase Blow-by Control System:

1. Visual inspect the carbon canister and hoses for damage.
2. leaking check.
3. Drain hose check.

Catalyst Converter:

1. Check if exhaust emission is within standard.
2. Remove the exhaust pipe and shake it slightly to check if noise.

Fuel Supply System:

1. Clean the air filter.
2. Check the air filter.
3. Make sure the fuel pressure supplied from the fuel pump.
4. Adjust CO/HC values at idle speed. (Engine rpm should be within specification)

Emission test items	CO	HC
Emission standard	4.50% or less	9000 ppm or less

Ignition system:

- Spark plug check and replacement.
- High voltage coil check and replacement.

17. Emission Control System

Countermeasure For Emission Pollutants Not Within Standard As In Idle Speed (4-Stroke Engine)

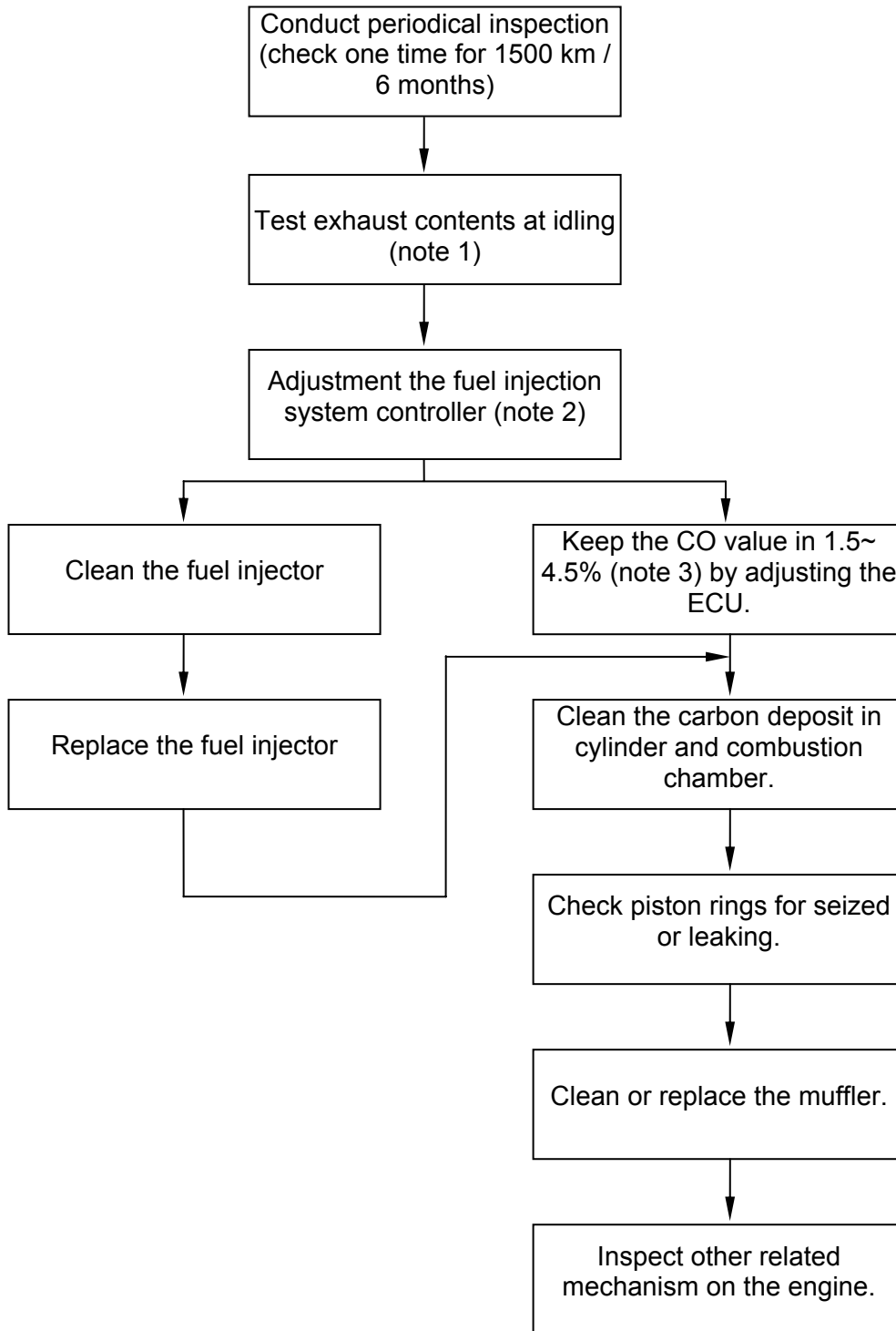

Note 1: test it according to the idling test procedure.

Note 2: Adjustment the idle adjustment screw. Set the engine rpm in specified speed, and test CO, HC at idling. And then adjust the air adjustment screw at the same time to let CO value to be 1.5~4.5%.

Note 3: If the values still can not be reached to specification after adjusted the fuel injection system controller, then clean or replace it with new one according to the replacement procedures.

HE15W Wiring Diagram

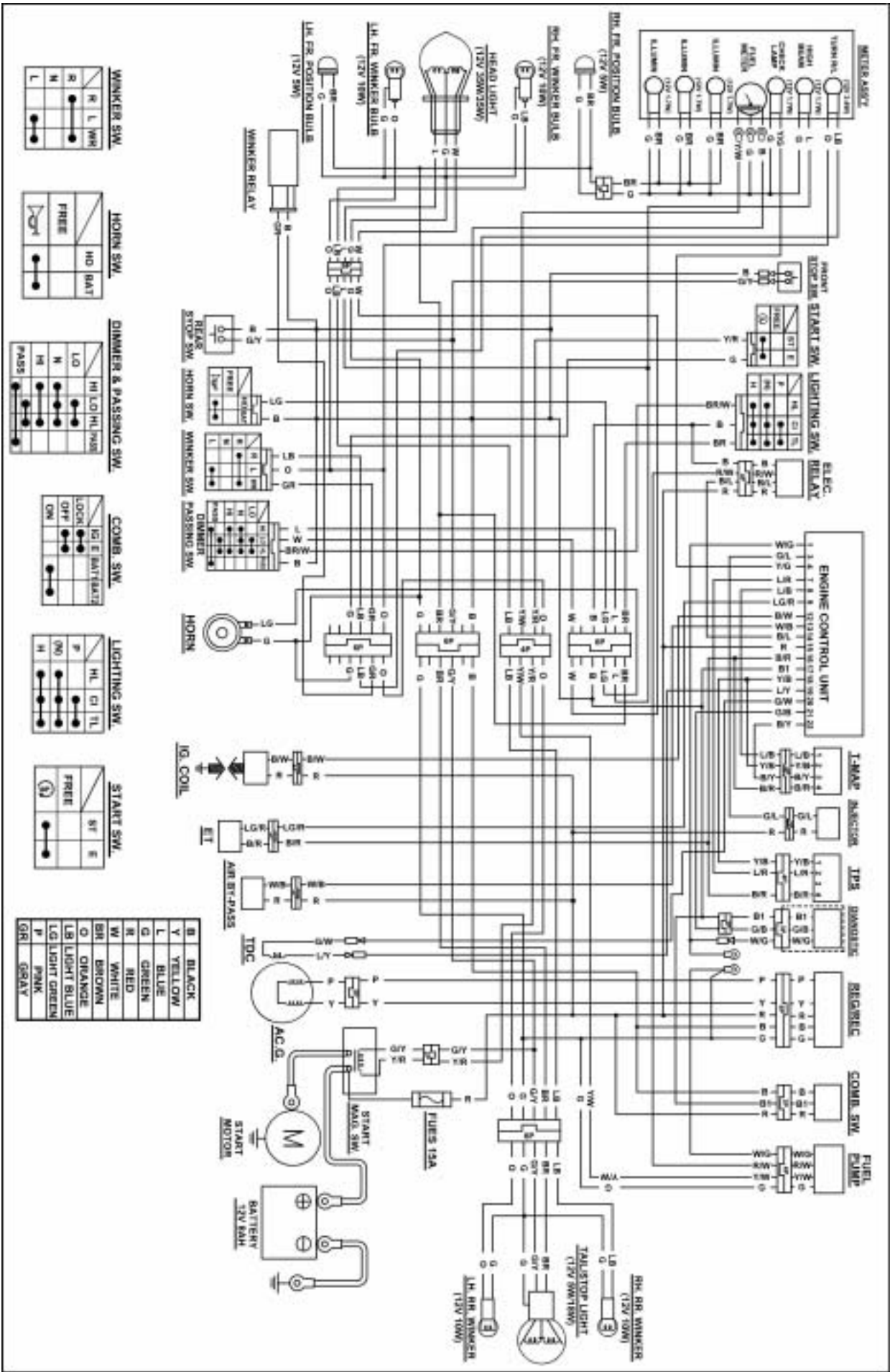

18. Wiring Diagram

NOTES: