



Joyride

SERVICE MANUAL

This service manual contains the technical data of each component inspection and repair for the Sanyang JOYRIDE 125/150/200 motorcycle. The manual is shown with illustrations and focused on “Service Procedures”, “Operation Key Points”, and “Inspection Adjustment” so that provides technician with service guidelines.

If the style and construction of the motorcycle, JOYRIDE 125/150/200, are different from that of the photos, pictures shown in this manual, the actual vehicle shall prevail. Specifications are subject to change without notice.

**Service Department
Sanyang Industry Co., LTD.**

This service manual describes basic information of different system parts and system inspection & service for Sanyang JOYRIDE 125/150/200 motorcycles. In addition, please refer to the manual contents in detailed for the model you serviced in inspection and adjustment.

The first chapter covers general information and trouble diagnosis.

The second chapter covers service maintenance information.

The third to the tenth chapters cover engine and driving systems.

The eleventh to the fourteenth is contained the parts set of assembly body.

The fifteenth chapter is electrical equipment.

The sixteenth chapter is emission control system.

The seventeenth chapter is wiring diagram

Please see index of content for quick having the special parts and system information.

There are link devices in the “H9A CONTENTS” file. Just only click on the icon and it will link to the article what you want to see.

All information, illustration, directions and specifications included in this manual are current as at the time of publication. Sanyang reserves the rights to make changes at any time without prior notice and without incurring any obligation whatever. Without written consent by Sanyang can not copy any part of this manual.

Page	Content	Index
1-1 ~ 1-16	GENERAL INFORMATION	1
2-1 ~ 2-12	MAINTENANCE INFORMATION	2
3-1 ~ 3-6	LUBRICATION SYSTEM	3
4-1 ~ 4-9	FUEL SYSTEM	4
5-1 ~ 5-6	ENGINE REMOVAL	5
6-1 ~ 6-14	CYLINDER HEAD/VALVE	6
7-1 ~ 7-8	CYLINDER/PISTON	7
8-1 ~ 8-14	V-BELT DRIVING SYSTEM/FOOT STARTER	8
9-1 ~ 9-8	FINAL DRIVING MECHANISM	9
10-1 ~ 10-6	ALTERNATOR/STARTING CLUTCH	10
11-1 ~ 11-8	CRANKSHAFT/CRANKCASE	11
12-1 ~ 12-11	COOLING SYSTEM	12
13-1 ~ 13-13	BODY COVERS	13
14-1 ~ 14-10	BRAKE	14
15-1 ~ 15-12	STEERING/FRONT WHEEL/FRONT BRAKE/ FRONT CUSHION	15
16-1 ~ 16-5	REAR WHEEL/REAR BRAKE/REAR CUSHION	16
17-1 ~ 17-18	ELECTRICAL SYSTEM	17
18-1 ~ 18-10	SPECIL TOOLS	18
19-1 ~ 19-2	WIRING DIAGRAM	18

MODEL ILLUSTRATION

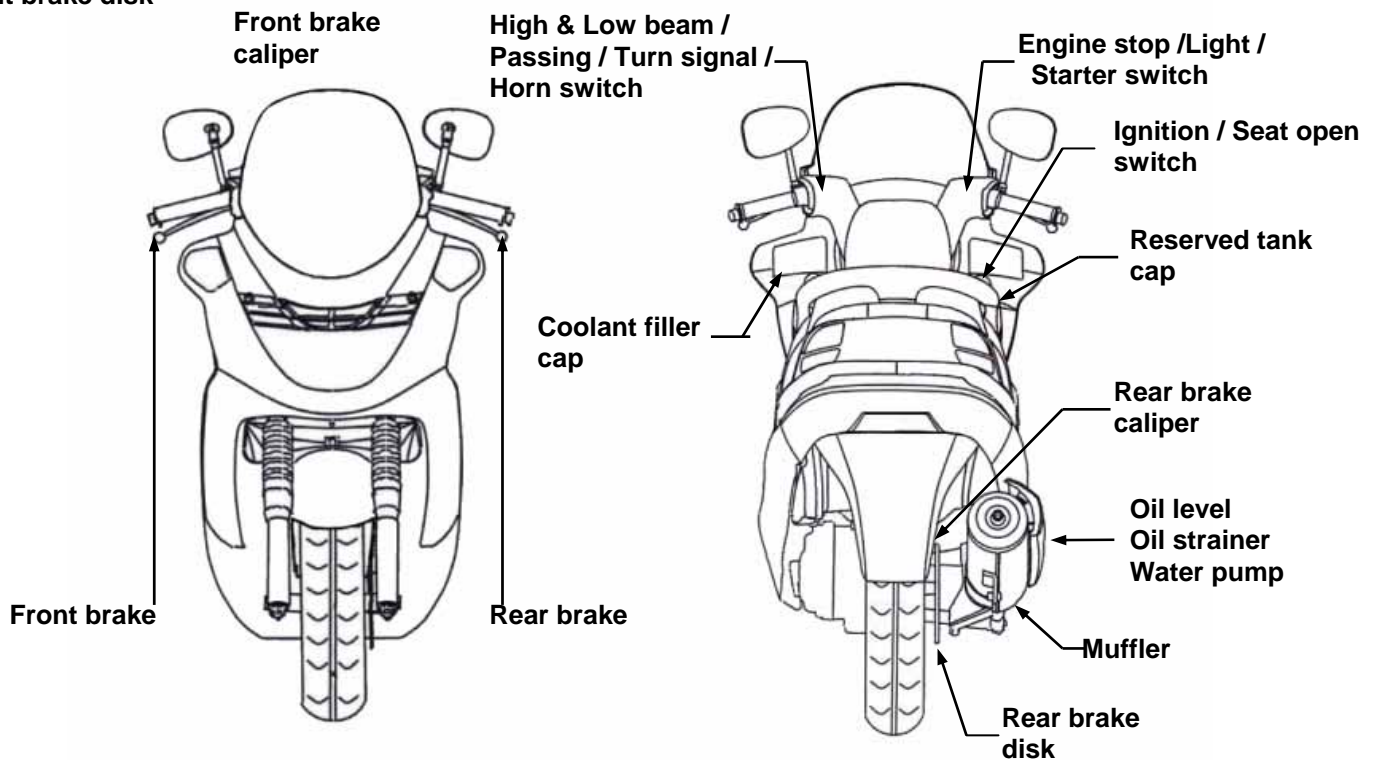
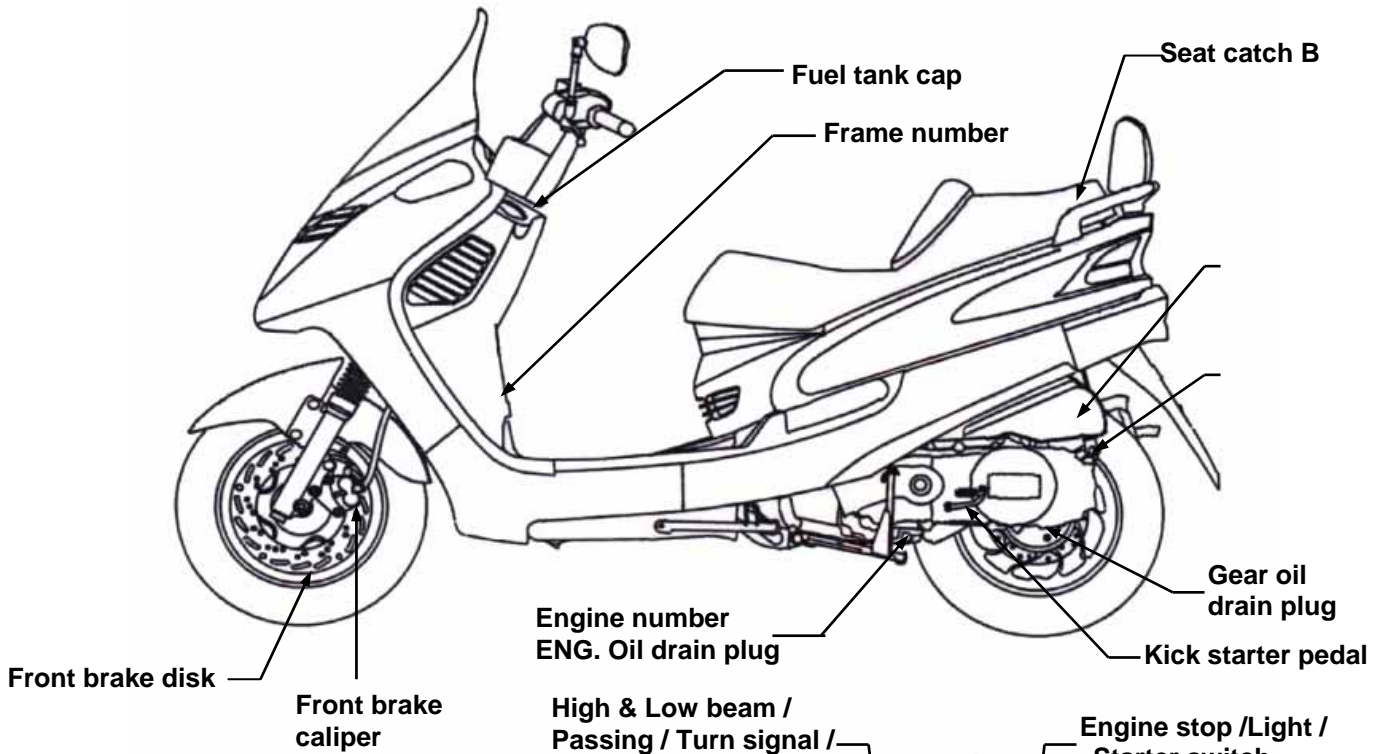
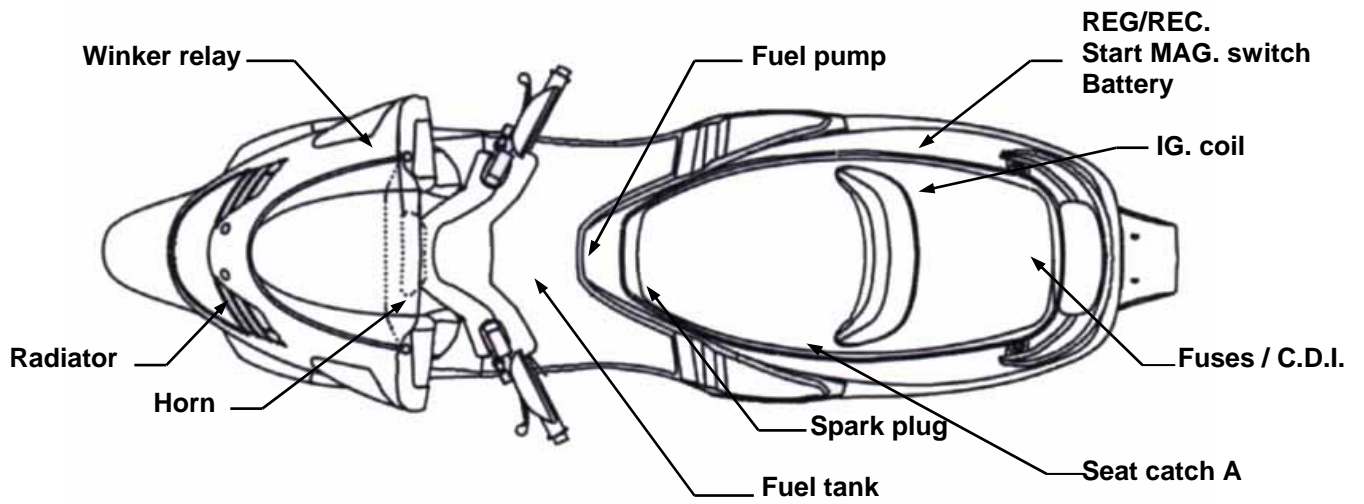

Symbols and marks.....1-1	Torque values.....1-8
General safety.....1-2	Cables and harness routing.....1-10
Service precautions.....1-3	Troubleshooting.....1-11
Specifications.....1-5	Lubrication points.....1-15

Symbols and Marks

Symbols and marks are used in this manual to indicate what and where the special service are needed, in case supplemental information is procedures needed for these symbols and marks, explanations will be added to the text instead of using the symbols or marks.

	Warning	Means that serious injury or even death may result if procedures are not followed.
	Caution	Means that equipment damages may result if procedures are not followed.
	Engine oil	Limits to use SAE 20 JASO FC class oil. Warranty will not cover the damage that caused by not apply with the limited engine oil. (Recommended oil: MAX-2 serial oils)
	Grease	King Mate G-3 is recommended.
	Gear oil	King Mate gear oil serials are recommended. (Bramax HYPOID GEAR OIL # 140)
	Locking sealant	Apply sealant, medium strength sealant should be used unless otherwise specified.
	Oil seal	Apply with lubricant.
	Renew	Replace with a new part before installation.
	Brake fluid	Use recommended brake fluid DOT3 or WELLRUN brake fluid.
	Special tools	Special tools.
	correct	Meaning correct installation.
	wrong	Meaning wrong installation.
	Indication	Indication of components.
	directions	Indicates position and operation directions.
		Components assembly directions each other.
		Indicates where the bolt installation direction, --- means that bolt cross through the component (invisibility).

General safety

Carbon monoxide

If you must run your engine, ensure the place is well ventilated. Never run your engine in a closed area. Run your engine in an open area, if you have to run your engine in a closed area, be sure to use an extractor.

Caution

Exhaust contains toxic gas which may cause one to lose consciousness and even result in death.

Gasoline

Gasoline is a low ignition point and explosive material. Work in a well-ventilated place, no flame or spark should be allowed in the work place or where gasoline is being stored.

Caution

Gasoline is highly flammable, and may explode under some conditions, keep it away from children.

Used engine oil

Caution

Prolonged contact with used engine oil (or transmission oil) may cause skin cancer although it might not be verified. We recommend that you wash your hands with soap and water right after contacting. Keep the used oil beyond reach of children.

Hot components

Caution

Components of the engine and exhaust system can become extremely hot after engine running. They remain very hot even after the engine has been stopped for some time. When performing service work on these parts, wear insulated gloves and wait until cooling off.

Battery

Caution

- Battery emits explosive gases; flame is strictly prohibited. Keep the place well ventilated when charging the battery.
- Battery contains sulfuric acid (electrolyte) which can cause serious burns so be careful do not be spray on your eyes or skin. If you get battery acid on your skin, flush it off immediately with water. If you get battery acid in your eyes, flush it off immediately with water and then go to hospital to see an ophthalmologist.
- If you swallow it by mistake, drink a lot of water or milk, and take some laxative such as castor oil or vegetable oil and then go to see a doctor.
- Keep electrolyte beyond reach of children.

Brake shoe

Do not use an air hose or a dry brush to clean components of the brake system, use a vacuum cleaner or the equivalent to avoid dust flying.

Caution

Inhaling brake shoe or pad ash may cause disorders and cancer of the breathing system.

Brake fluid

Caution

Spilling brake fluid on painted, plastic, or rubber parts may cause damage to the parts. Place a clean towel on the above-mentioned parts for protection when servicing the brake system. Keep the brake fluid beyond reach of children.

Service Precautions

- Always use with Sanyang genuine parts and recommended oils. Using non-designed parts for Sanyang motorcycle may damage the motorcycle.
- Special tools are designed for remove and install of components without damaging the parts being worked on. Using wrong tools may result in parts damaged.
- When servicing this motorcycle, use only metric tools. Metric bolts, nuts, and screws are not interchangeable with the English system, using wrong tools and fasteners may damage this vehicle.
- Clean the outside of the parts or the cover before removing it from the motorcycle. Otherwise, dirt and deposit accumulated on the part's surface may fall into the engine, chassis, or brake system to cause a damage.
- Wash and clean parts with high ignition point solvent, and blow dry with compressed air. Pay special attention to O-rings or oil seals because most cleaning agents have an adverse effect on them.

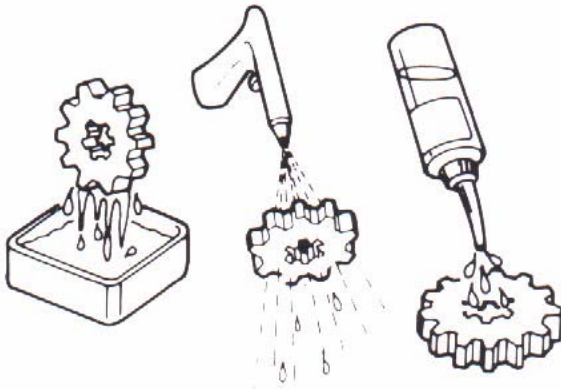

- Never bend or twist a control cable to prevent unsmooth control and premature worn out.



- Rubber parts may become deteriorated when old, and prone to be damaged by solvent and oil. Check these parts before installation to make sure that they are in good condition, replace if necessary.
- When loosening a component which has different sized fasteners, operate with a diagonal pattern and work from inside out. Loosen the small fasteners first. If the bigger ones are loosen first, small fasteners may receive too much stress.
- Store complex components such as transmission parts in the proper assemble order and tie them together with a wire for ease of installation later.

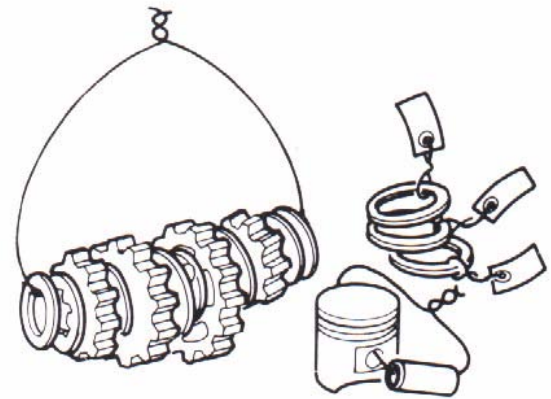

- Note the reassemble position of the important components before disassembling them to ensure they will be reassembled in correct dimensions (depth, distance or position).
- Components not to be reused should be replaced when disassembled including gaskets metal seal rings, O-rings, oil seals, snap rings, and split pins.



Caution

In addition to damaging paint finish, brake oil can also damage the structural integration of plastic or rubber parts.

1. GENERAL INFORMATION

- The length of bolts and screws for assemblies, cover plates or boxes is different from one another, be sure they are correctly installed. In case of confusion, Insert the bolt into the hole to compare its length with other bolts, if its length out side the hole is the same with other bolts, it is a correct bolt. Bolts for the same assembly should have the same length.

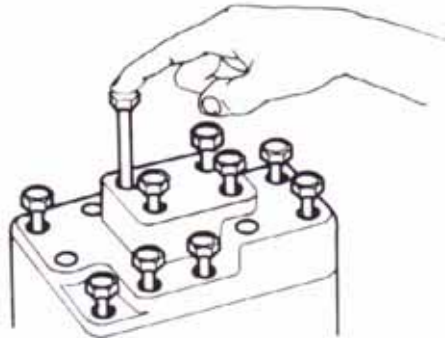

- Tighten assemblies with different dimension fasteners as follows: Tighten all the fasteners with fingers, then tighten the big ones with special tool first diagonally from inside toward outside, important components should be tightened 2 to 3 times with appropriate increments to avoid warp unless otherwise indicated. Bolts and fasteners should be kept clean and dry. Do not apply oil to the threads.
- When oil seal is installed, fill the groove with grease, install the oil seal with the name of the manufacturer facing outside, check the shaft on which the oil seal is to be installed for smoothness and for burrs that may damage the oil seal.

Manufacturer's name



- Remove residues of the old gasket or sealant before reinstallation, grind with a grindstone if the contact surface has any damage.



- The ends of rubber hoses (for fuel, vacuum, or coolant) should be pushed as far as they can go to their connections so that there is enough room below the enlarged ends for tightening the clamps.

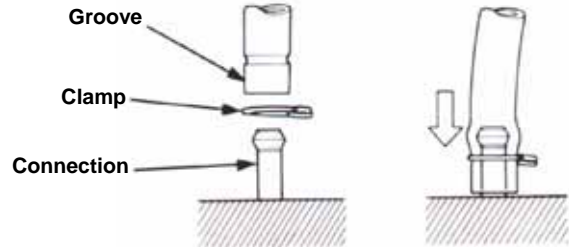

- Rubber and plastic boots should be properly reinstalled to the original correct positions as designed.

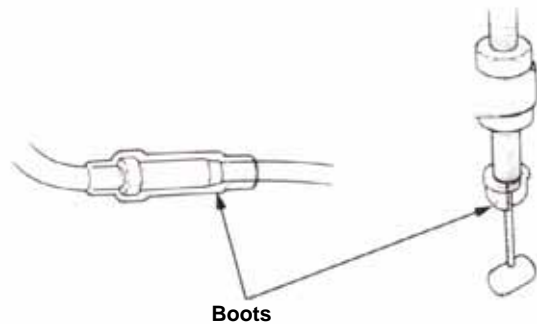

- The tool should be pressed against two (inner and outer) bearing races when removing a ball bearing. Damage may result if the tool is pressed against only one race (either inner race or outer race). In this case, the bearing should be replaced. To avoid damaging the bearing, use equal force on both races.

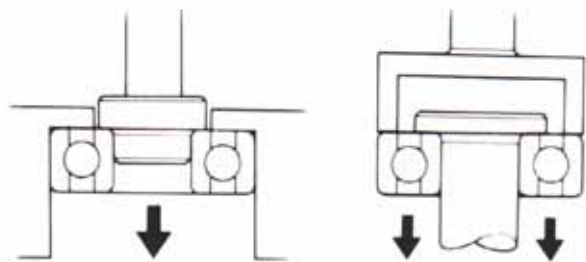

Both of these examples can result in bearing damage.

- Lubricate the rotation face as assembling. Check if positions and operation for installed parts is in correct and properly.

Specifications

Make		SANYANG		MODEL		LA12W		
WEIGHT DIMENSION	Overall Length	2010 mm		Suspension System	Front	TELESCOPIC FORK		
	Overall Width	760 mm			Rear	UnIT SWING		
	Overall Height	1155 mm		Tire Specifications	Front	110 / 80-12 61L		
	Wheel Base	1440 mm			Rear	130 / 70-12 64L		
	Curb Weight	Front	55 kg		Brake System	Front	DISK (ϕ 273mm)	
		Rear	89 kg			Rear	DISK (ϕ 200mm)	
		Total	144 kg					
	Passengers/	Two /110 kg		PERFORMANCE	Max. Speed		99 km/hr Above	
	Weight				Climb Ability		28° above	
	Total Weight	Front	79 kg		Primary Reduction		BELT	
Rear		175 kg			Secondary Reduction		GEAR	
Total		254 kg			Clutch		3-piece centrifugal, dry type	
Type	Gasoline		Transmission		C.V.T.			
Position and arrangement	Horizontal, below center, CYL incline 80°		Speed meter		0 ~ 140 km/hr			
Fuel Used	>92 Unleaded gasoline		Horn		93 – 112 dB/A			
Cycle/Cooling	4-stroke/water cooled		Muffler		Expansion & Pulse Type			
Cylinder	Bore	ϕ 57 mm			Exhaust Pipe Position and Direction		Right side, and Backward	
	Stroke	48.8 mm		Lubrication System		Forced pressure and wet sump		
	Number/Arrangement	Single Cylinder		Exhaust Concentration		Solid Particulate		
Displacement	124.5 cc		CO		3.5 % ↓			
Compression Ratio	10.5 : 1		HC		Below 2000 ppm			
Max. HP	11.4 / 8500 ps/rpm		E.E.C.		Non-equipped			
Max. Torque	1.01 / 7000 kg-m/rpm		P.C.V.		Equipped			
Ignition	C.D.I.		Catalytic reaction control system		Non-equipped			
Starting System	Power & Foot							
Remark:								

1. GENERAL INFORMATION



Specifications

Make		SANYANG		MODEL		LA15W		
WEIGHT DIMENSION	Overall Length	2010 mm		Suspension System	Front	TELESCOPIC FORK		
	Overall Width	760 mm			Rear	UNIT SWING		
	Overall Height	1155 mm		Tire Specifications	Front	110 / 80-12 61L		
	Wheel Base	1440 mm			Rear	130 / 70-12 64L		
	Net Weight	Front	55 kg		Brake System	Front	DISK (ϕ 273mm)	
		Rear	89 kg			Rear	DISK (ϕ 200mm)	
		Total	144 kg					
	Passengers/Weight		Two /110 kg		PERFORMANCE	Max. Speed		100 km/hr Above
	Total Weight	Front	79 kg			Climb Ability		28° above
		Rear	175 kg			Primary Reduction		BELT
Total		254 kg		Secondary Reduction		GEAR		
Type		Gasoline		Clutch		3-piece centrifugal, dry type		
Position and arrangement		Horizontal, below center, CYL incline 80°		Transmission		C.V.T.		
Fuel Used		>92 Unleaded gasoline		Speed meter		0 ~ 140 km/hr		
Cycle/Cooling		4-stroke/water cooled		Horn		70 – 90 dB/A		
ENGINE	Cylinder	Bore	ϕ 57 mm		Muffler		Expansion & Pulse Type	
		Stroke	58.6 mm		Exhaust Pipe Position and Direction		Right side, and Backward	
		Number/Arrangement	Single Cylinder		Lubrication System		Forced pressure and wet sump	
Displacement		149.5 cc		Exhaust Concentration	Solid Particulate			
Compression Ratio		10.5 : 1			CO		3.5 % ↓	
Max. HP		13 / 8000 ps/rpm			HC		Below 2000 ppm	
Max. Torque		1.2 / 6000 kg-m/rpm		E.E.C.		Non-equipped		
Ignition		C.D.I.		P.C.V.		Equipped		
Starting System		Power & Foot		Catalytic reaction control system		Non-equipped		
Remark:								

Specifications

Make		SANYANG		MODEL		LA18W		
WEIGHT DIMENSION	Overall Length	2010 mm		Suspension System	Front	TELESCOPIC FORK		
	Overall Width	760 mm			Rear	UNIT SWING		
	Overall Height	1155 mm		Tire Specifications	Front	110 / 80-12 61L		
	Wheel Base	1440 mm			Rear	130 / 70-12 64L		
	Curb Weight	Front	55 kg		Brake System	Front	DISK (φ 273mm)	
		Rear	89 kg			Rear	DISK (φ 200mm)	
		Total	144 kg					
	Passengers/Weight	Two / 110 kg		PERFORMANCE	Max. Speed	100 km/hr Above		
	Total Weight	Front	79 kg		Climb Ability	28° above		
		Rear	175 kg		Primary Reduction	BELT		
Total		254 kg			Secondary Reduction	GEAR		
Type	Gasoline		Clutch		3-piece centrifugal, dry type			
Position and arrangement	Horizontal, below center, CYL incline 80°		Transmission		C.V.T.			
Fuel Used	>92 Unleaded gasoline		Speed meter	0 ~ 140 km/hr				
Cycle/Cooling	4-stroke/water cooled		Horn	93 – 112 dB/A				
Cylinder	Bore	Ø 61 mm		Muffler	Expansion & Pulse Type			
	Stroke	58.6 mm		Exhaust Pipe Position and Direction	Right side, and Backward			
	Number/Arrangement	Single Cylinder		Lubrication System	Forced pressure and wet sump			
Displacement	171.2 cc		Exhaust Concentration	Solid Particulate				
Compression Ratio	10 : 1			CO	3.5 % ↓			
Max. HP	14.5 / 8000 ps/rpm			HC	Below 2000 ppm			
Max. Torque	1.4 / 6500 kg-m/rpm		E.E.C.	Non-equipped				
Ignition	C.D.I.		P.C.V.	Non-equipped				
Starting System	Power & Foot		Catalytic reaction control system	Non-equipped				
Remark:								

1. GENERAL INFORMATION



Torque values

Item	Q'ty	Thread Dia. (mm)	Torque Value (Kgf-m)	Remarks
Cylinder head bolt	4	8	2.0-2.4	Apply oil to thread
Valve clearance adjust nut	4	5	0.7-1.1	
Spark plug	1	10	1.0-1.4	
L. Crankcase cover bolts	7	6	1.1-1.5	
Crankcase bolts	7	6	0.8-1.2	
Oil drain bolt	1	8	1.1-1.5	
Oil strainer cap	1	30	1.3-1.7	
Gear oil drain bolt	1	6	1.0-1.4	
Gear oil inspection bolt	1	6	1.0-1.4	
Transmission cover bolt	7	6	1.0-1.4	
Flywheel bolt	1	14	5.0-6.0	
Clutch driving plate bolt	1	28	5.0-6.0	
Driving disc nut	1	12	5.0-6.0	
Clutch outer cover nut	1	10	3.5-4.5	
Transmission cover bolts	7	6	1.0-1.4	
Stopper nut for engine hanger bracket	1	8	1.8-2.2	
Nut for engine hanger bracket	1	10	4.0-5.0	
Bolt for engine hanger bracket	1	10	4.0-5.0	
Engine mounting bolt	1	10	3.5-4.5	
Front wheel shaft nut	1	12	5.0-7.0	
Rear wheel shaft nut	1	14	11.0-13.0	
Bolt for rear shock absorber (upper)	2	10	3.5-4.5	
Bolt for rear shock absorber (under)	2	8	2.4-3.0	
Bolt for steering rod	1	10	4.0-5.0	
Front shock absorber	4	8	2.4-3.0	
Brake arm bolts	2	6	0.8-1.2	
Brake hose bolts	4	10	3.3-3.7	
Bolt for brake caliper	4	10	3.0-3.5	
Bolts for the lining guide pin	4	6	1.6-2.0	
Brake disk bolts	7	10	4.0-4.5	
Mounting screw for speedometer cable	1	5	0.15-0.3	
Muffler bolts	4	8	3.2-3.8	
Mounting bolts for exhaust pipe connection	2	7	1.0-1.2	

The torque values listed in above table are for more important tighten torque values. Please see standard values for not listed in the table.

Standard Torque Values for Reference

Type	Torque value kgf-m
5 mm Bolt, Nut	0.45 - 0.6
6 mm Bolt, Nut	0.8 - 1.2
8 mm Bolt, Nut	1.8 - 2.5
10 mm Bolt, Nut	3.0 - 4.0
12 mm Bolt, Nut	5.0 - 6.0
5 mm Screw	0.35 - 0.5
6 mm Screw & 6mm bolt with 8mm head	0.7 - 1.1
6 mm Flange bolt, nut	1.0 - 1.4
8 mm Flange bolt, nut	2.4 - 3.0
10 mm Flange bolt, nut	3.5 - 4.5

Cables and harness routing

Note the following when routing cables and wire harnesses:

- A loose wire, cable or harness may cause safety hazard. After clamping, check each wire to make sure it is secured.
- Do not squeeze wires against the weld or its clamp.
- Secure wires and wire harnesses to the frame with respective wire bands at the designated locations. Tighten the bands so that only the insulated surfaces contact the wires or wire harnesses.
- Route harnesses so that they neither pull too tight nor have excessive slack.
- Protect wires or wire harnesses with electrical tape or tube if they contact a sharp edge or corner.
- Route wire harnesses to avoid sharp edges or corners.
- Avoid the projected ends of bolts and screws.
- Keep wire harnesses far away from the exhaust pipes and other hot parts.
- Be sure grommets are seated in their groves properly.
- After clamping, check each harness to be certain that it is not interfered with any moving or sliding parts.
- After routing, check that the wire harnesses are not twisted or kink.
- Wire harnesses routed along the handlebar should not be pulled too tight or have excessive slack, be rubbed against or interfere with adjacent or surrounding parts in all steering positions.
- Thoroughly clean the surface where tape is to be applied.
- Wrap electrical tape around the damaged parts or replace them.

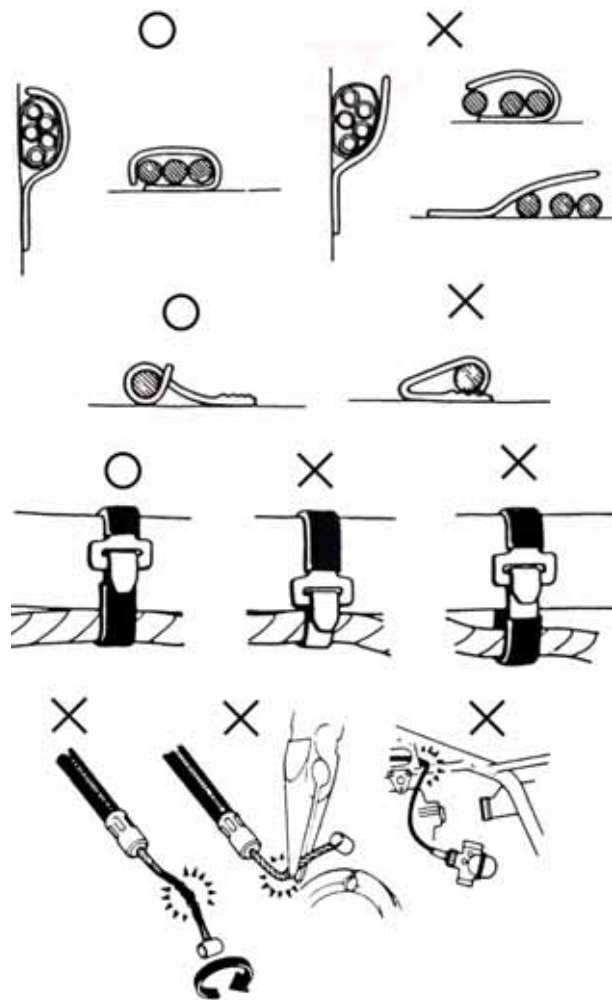

○ : correct
 ✕ : wrong

Troubleshooting

A. Engine hard to start or can not be started

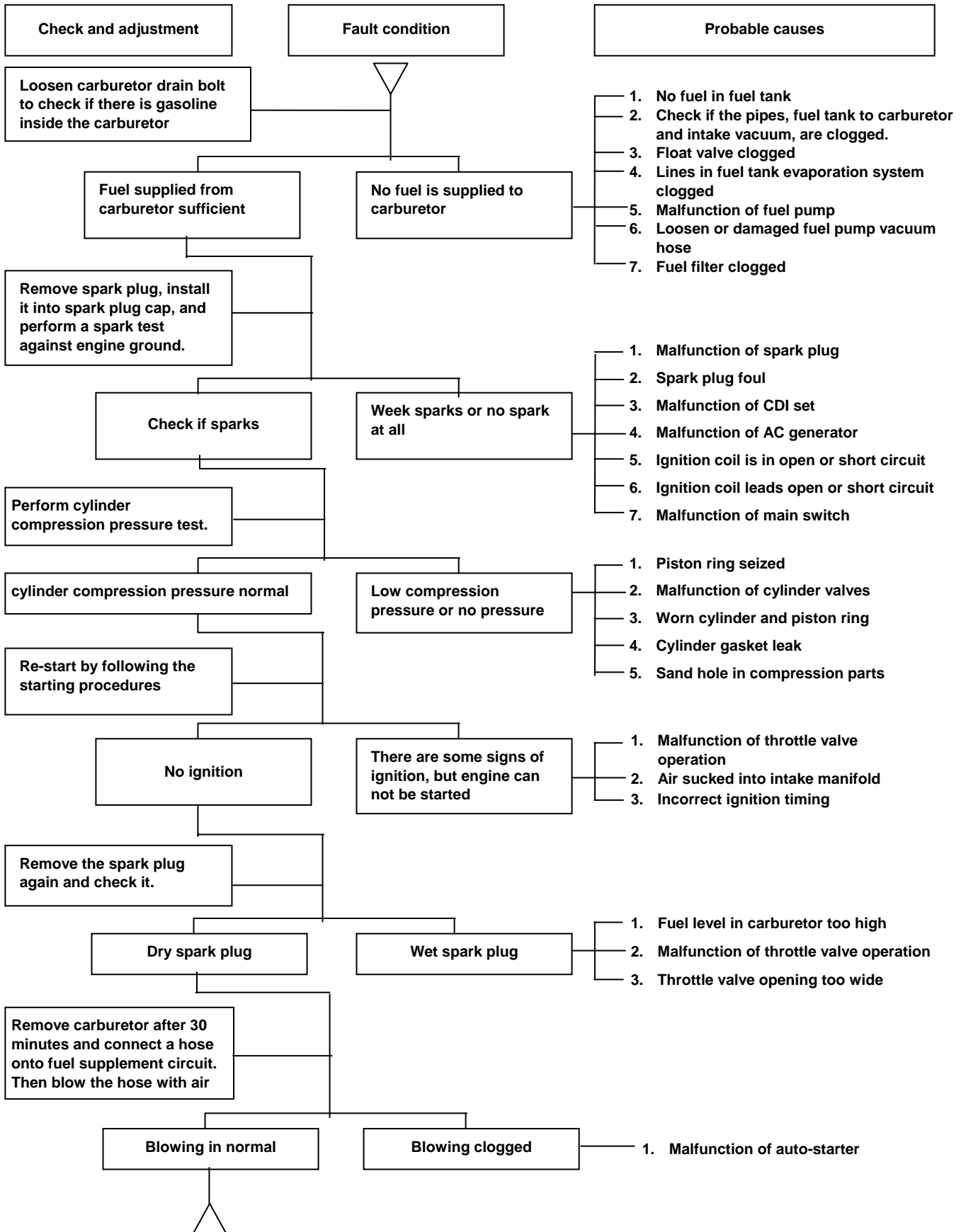

B. Engine run sluggish (Speed does not pick up, lack of power)

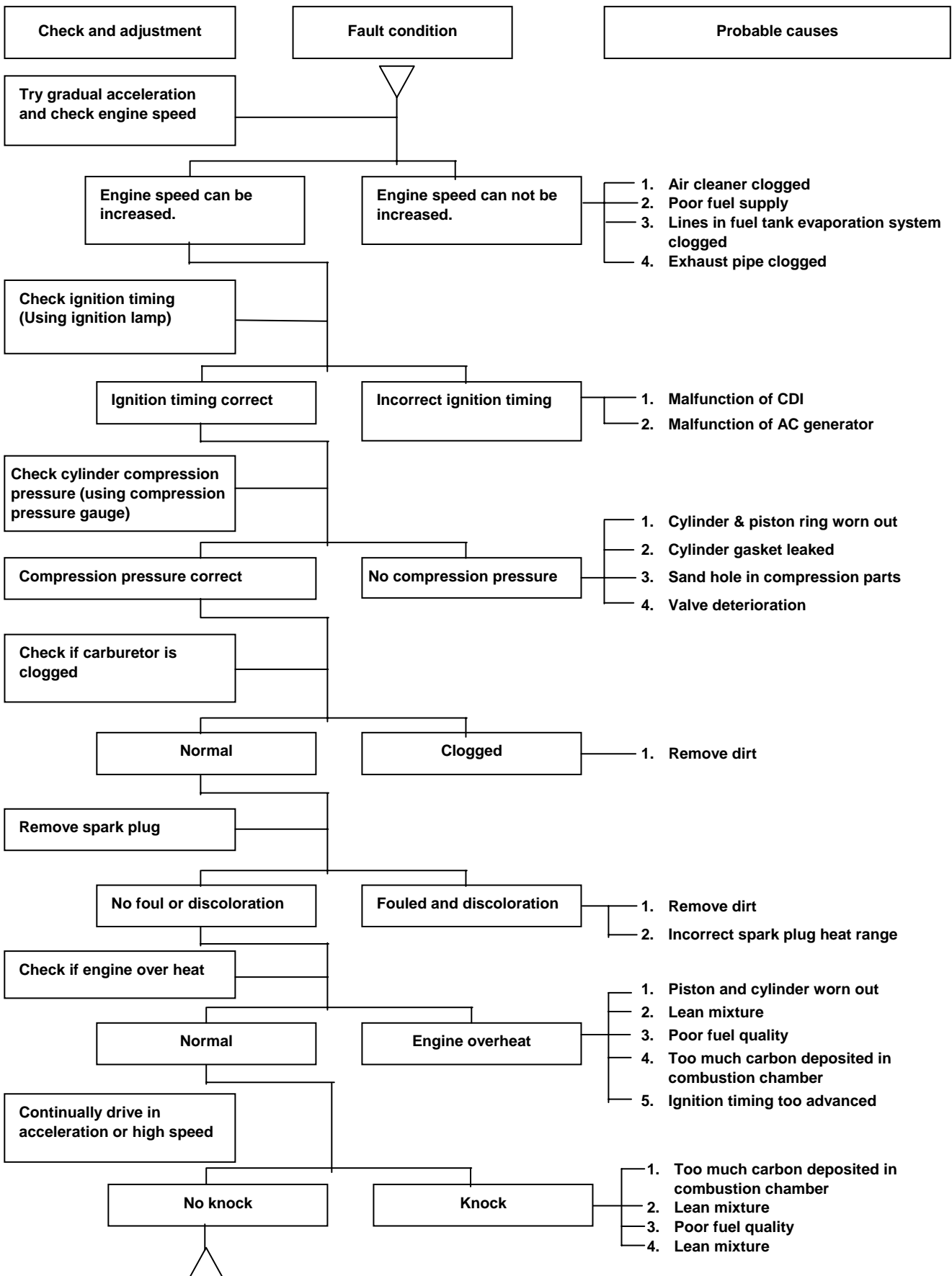

C. Engine runs sluggish (especially in low speed and idling)

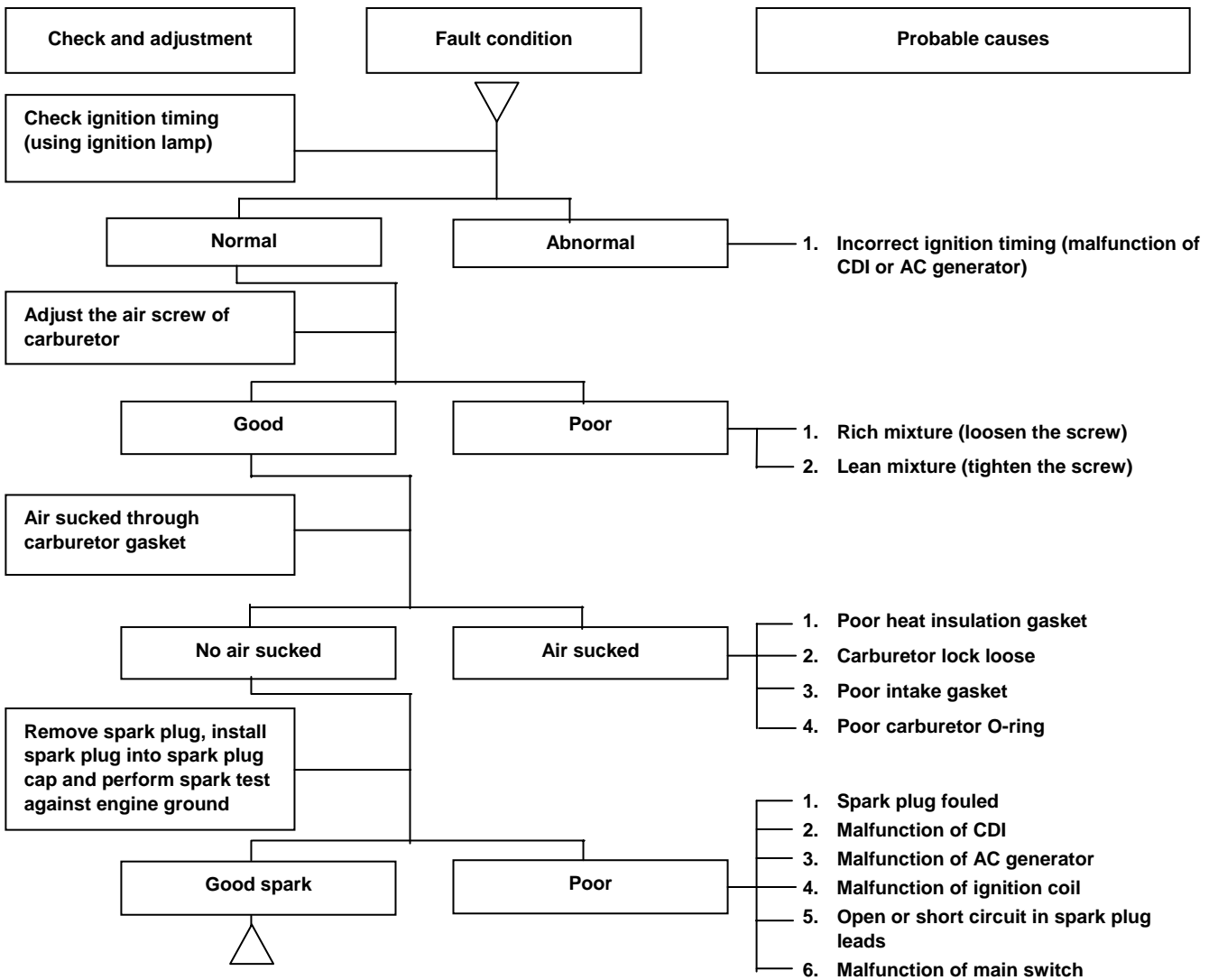

D. Engine runs sluggish (High speed)

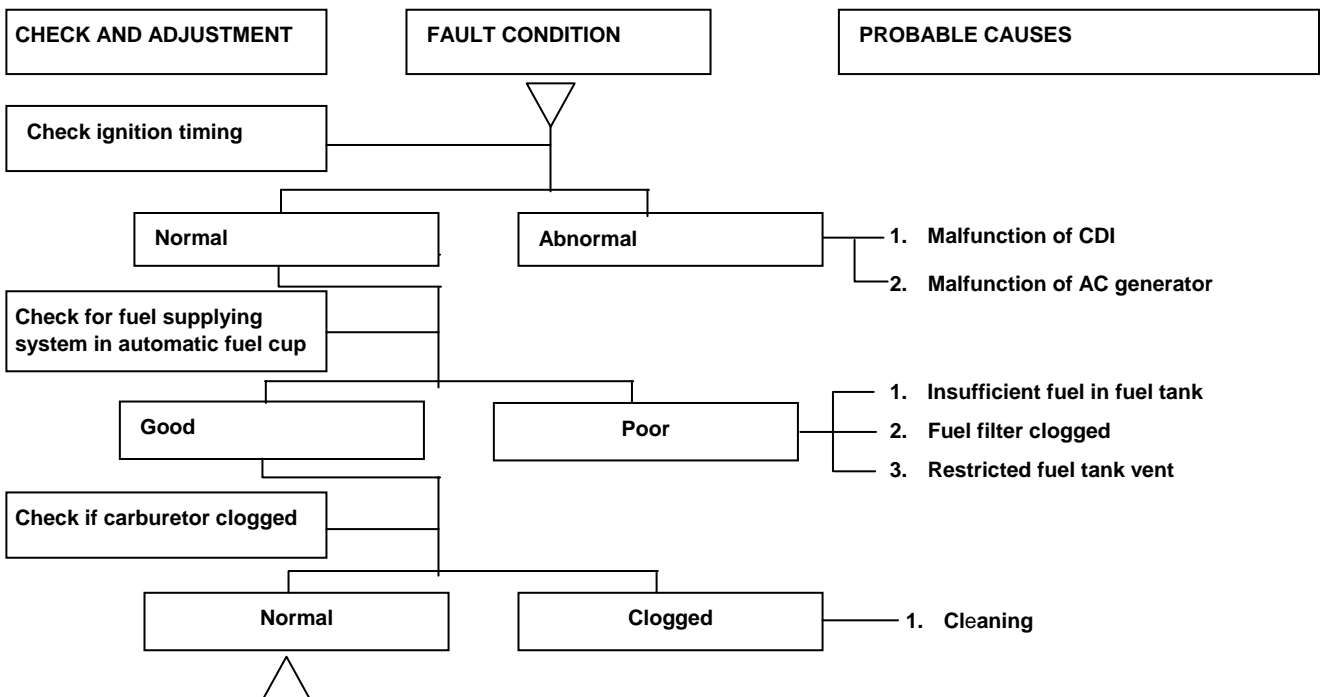

E. CLUTCH, DRIVING AND DRIVING PULLEY

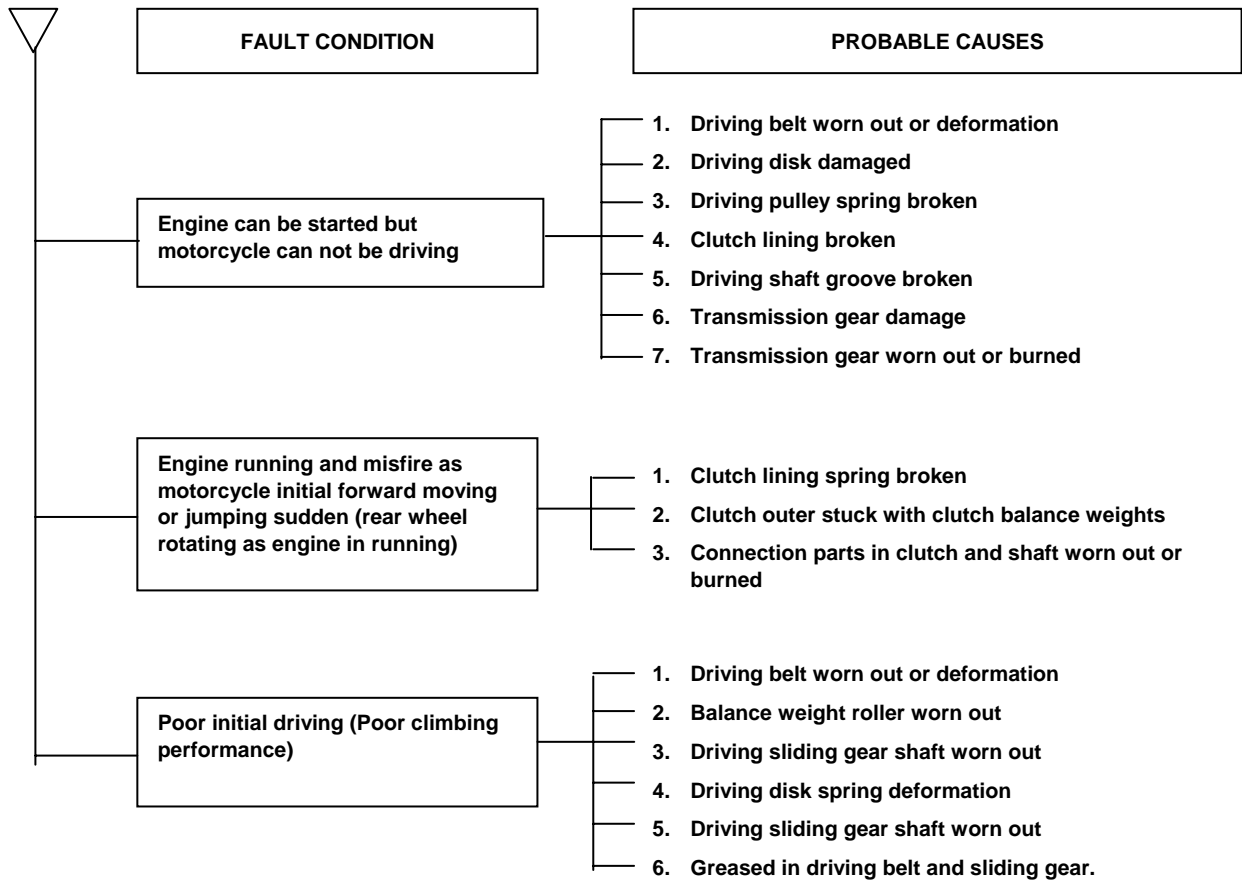

LUBRICATION POINTS

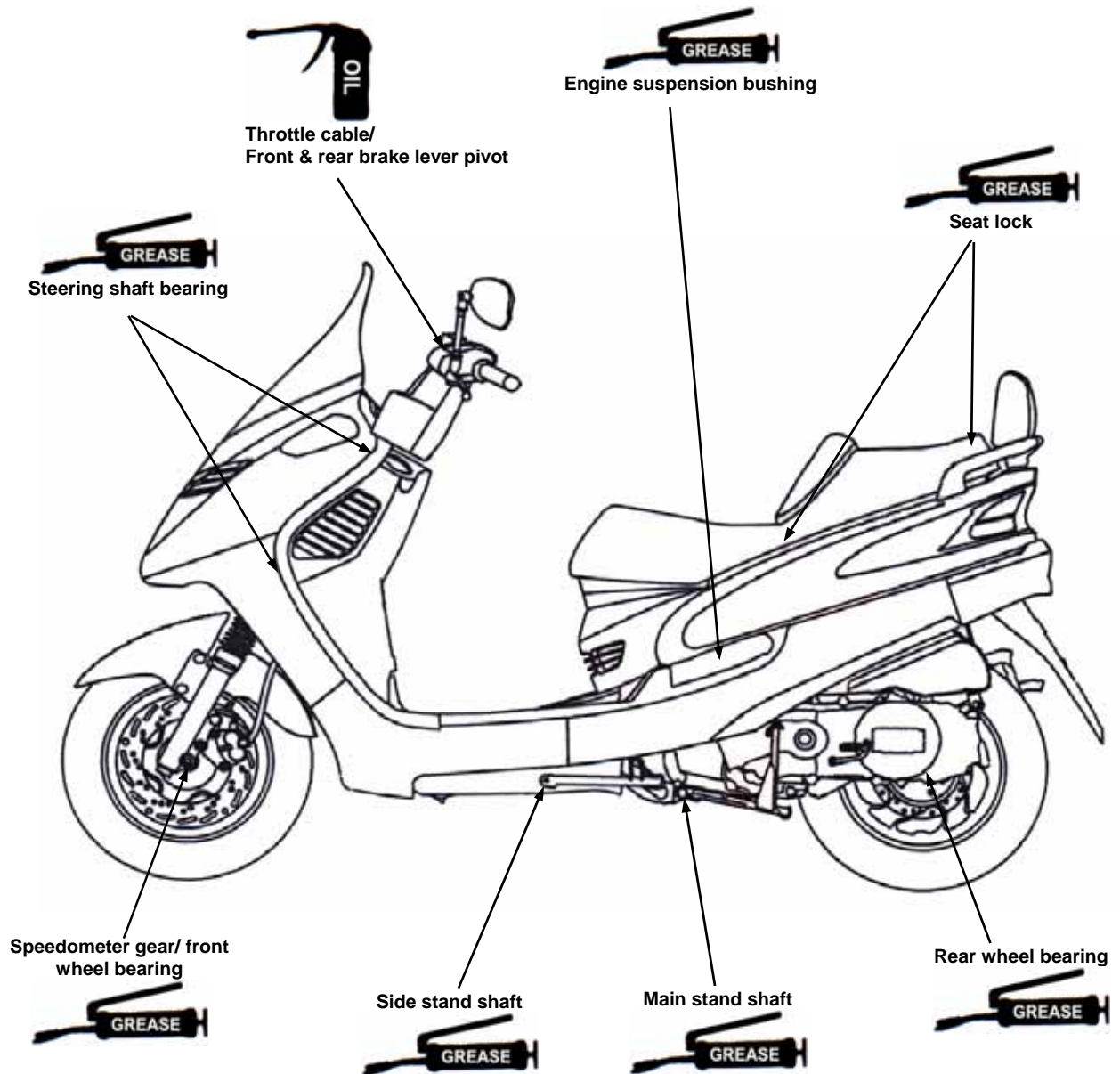

NOTES:

Precautions in operation	2-1	Brake system hose.....	2-8
Periodical maintenance schedule	2-2	Brake fluid.....	2-8
Fuel Lines	2-3	Filling out brake fluid	2-8
Acceleration operation	2-3	Air bleed operation.....	2-9
Air cleaner	2-4	Added brake fluid	2-9
Crankcase ventilation	2-4	Brake lining wear.....	2-9
Spark plug	2-4	Brake lamp switch/Starting inhibitor switch.....	2-10
Valve clearance	2-5	Headlamp beam distance	2-10
Carburetor idling speed adjustment.....	2-6	Clutch disc wear.....	2-10
Ignition system.....	2-6	Side stand	2-11
Cylinder compression pressure ..	2-7	Shock absorber	2-11
Driving belt	2-7	Nut, bolts tightness.....	2-11
Brake system (front/rear disk brake).....	2-8	Wheel/Tire	2-12
		Steering handle top bearing.....	2-12

定期整備

一般情報		仕様	
エンジンオイル	2-2 ページを参照	アクセルの遊び	2.6 mm
エンジンオイルストレーナー	2-2 ページを参照	点火プラグ：標準	CR8E
ギヤオイル	2-6 ページを参照	プラグギャップ	0.8~0.9 mm

点火時期

点火マーク		BTDC 13° at 1000 rpm
点火タイミング		BTDC 13° at 1000 rpm
最大進角		BTDC 26° at 6000 rpm
アイドリング回転数		1600 ± 100 rpm
シリンダー圧縮圧力		12 ± 2 Kg/cm ²
バルブクリアランス: IN/EX		0.12 ± 0.02 mm

車体

ブレーキ	フロントブレーキ遊び		10~20 mm
	リアブレーキ遊び		10~20 mm

ホイール

項目	フロントホイール	リアホイール
ホイールサイズ	3.50-10-4PR	3.50-10-4PR
冷間時タイヤ空気圧 (Kg/cm ²)	1.5	2.0

2. MAINTENANCE INFORMATION



Load 90 Kg (最大積載時) (Kg/cm ²)	1.5	2.5
--	-----	-----

定期整備スケジュール

メンテナンス コード	項目	300KM 毎	1ヶ月又は 1000KM 毎	3ヶ月又は 3000KM 毎	6ヶ月又は 6000KM 毎	1年又は 12000KM 毎	15ヶ月又は 14500KM 毎
1	☆エアクリナー	I		C	C	R	C
2	☆セクタリアジエット	I		C	C	R	C
3	☆フェイルフィルター	I			I	R	
4	☆オイルフィルター	C			C	C	
5	☆エンジンオイル交換	R	以後1000 km毎に交換				
6	タイヤ空気圧	I	I	I	I	I	I
7	バッテリー検査	I	I	I	I	I	I
8	ブレーキ&遊び点検	I	I	I	I	I	I
9	ステアリングハンドル点検	I			I	I	
10	クッション作動点検	I			I	I	
11	すべてのスクリューの締付点検	I	I	I	I	I	I
12	ギヤオイル&油漏れ点検	I	I	I	I	I	I
13	☆点火プラグ点検交換	I		I	R	R	R
14	☆ギヤオイル交換	R	以後5000 km毎に交換				
15	車体給油				L	L	
16	マフラーパイプ	I	I	I	I	I	I
17	☆点火時期	I	I	I	I	I	I
18	☆アイドリング排気ガス検査	A	I	I	I	I	I
19	☆スロットル作動	I		I	I	I	I
20	☆エンジンボルト締付	I		I	I	I	I
21	☆CVT駆動装置(ベルト)				I	R	I
22	☆CVT駆動装置(ロー)				C	C	C
23	ライト/電気装置/マルチメーター	I	I	I	I	I	I
24	メイン・サイドスタンド & ストップリング	I			I	I	
25	フェイルライン	I		I	I	I	I
26	ショックアブソーバー			I	I	I	I
27	カチオン	I		I	I	I	I
28	☆バルブクリアランス	I		A	A	A	A
29	☆クランクケース蒸発ガスクontroルシステム	I		C	C	C	C
30	☆クランクケースローバンプオーバーフローパイプ		2000 kmに繰り返す				
31	☆セクタリアジエットシステム	I		I	C	C	C
32	☆蒸発ガスクontroルシステム			I	I	I	I
33	冷却システムラインと接続状態	I	I	I	I	I	I
34	ラジエーターパイプ	I	I	I	I	I	I
35	ラジエーター液	I	1年毎に交換				

記号: I ~ 点検し、清掃と調整 R ~ 交換 C ~ 清掃(もしひどければ交換) L ~ 給油

あなたのスクーターを点検、調整して最適な状態を維持していくために SYM 特約店で整備をして、定期的なメンテナンスを記録しておく事を勧めます。

上記のメンテナンス予定は、これまでに最初になる参照として毎月の1000キロメートルを必要とすることによって確立されます。

注:

1. 予定のこれらのマーク「☆」は、エミッションコントロールアイテムです。EPA規則に従って、これらのアイテムは、取り扱い説明の後の実行された通常周期的なメンテナンスでなければなりません。資格を持った整備士によって点検調整するようにして下さい。その整備料金はSYMとは関係がなく、特約店独自に決められています。
2. オートバイが埃っぽい道で操縦される、あるいは、途中で環境を汚染した時は清掃するか、よりしばしばエアクリナーを取り替えてください。
3. スクーターが高速でしばしば操縦されたり、より多くの距離を走行したあとはメンテナンスはよりしばしば実行されなければなりません。
4. 予防的なメンテナンス
 - a. 点火システム—連続的な異常な点火、不発、アフターバーンする時、メンテナンスを実行して、チェックすれば、オーバーヒートを防ぎます
 - b. Carbon deposit removal—Remove carbon deposits in cylinder head, piston heads, exhaust system when power is obvious lower. Than ever
 - c. Replace worn out pistons, cylinder head.

FUEL LINES

Remove trunk.
Remove side cover.
Remove central cover.
Remove body frame cover.
Remove pedal.
Remove front glove box.
Check all lines, and replace it when they are deterioration, damage or leaking.

Warning

Gasoline is a low ignition material so any kind of fire is strictly prohibited as dealing it.

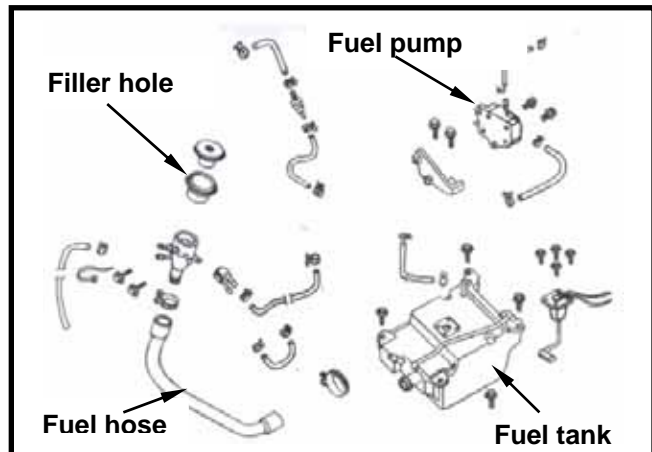

ACCELERATION OPERATION

Have a wide open of throttle valve as handle bar in any position and release it to let back original (full closed) position.
Check handle bar if its operation is smooth.
Check acceleration cable and replace it if deteriorated, twisted or damaged.



Lubricate the cable if operation is not smooth.
Measure handle bar free play in its flange part.

Free play: 2~6 mm.

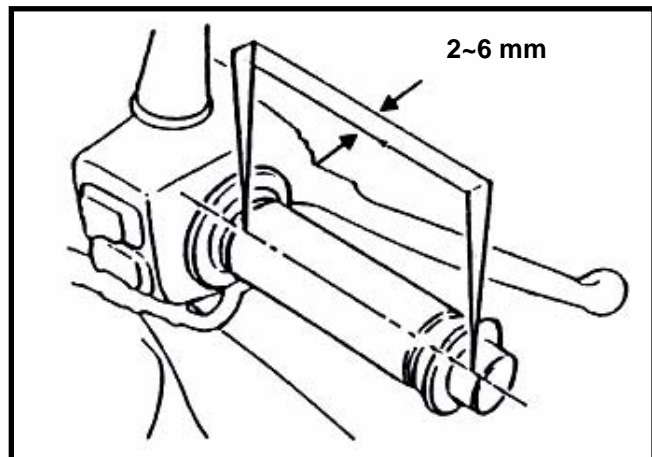

Adjustment can be done in either end.
Secondary adjustment is conducted from top side.
Remove rubber boot, loosen fixing nut, and then adjust it by turning the adjustment nut.

Primary adjustment is conducted from bottom side.
Loosen fixing nut, and adjust by turning the adjustment nut.
Tighten the fixing nut, and check acceleration operation condition.



AIR CLEANER

Remove trunk.
Remove side cover.
Remove 8 screws from the air cleaner cover and then remove the cover.

Caution

Air cleaner element contains a paper made filter so do not try to clean it.



CRANKCASE VENTILATION

Pull out the plug from draining hose to clean deposit.

Caution

When always riding in rainy area or full throttle position, maintenance travel must be shorted. The deposits can be seen in the transparent section of draining hose.

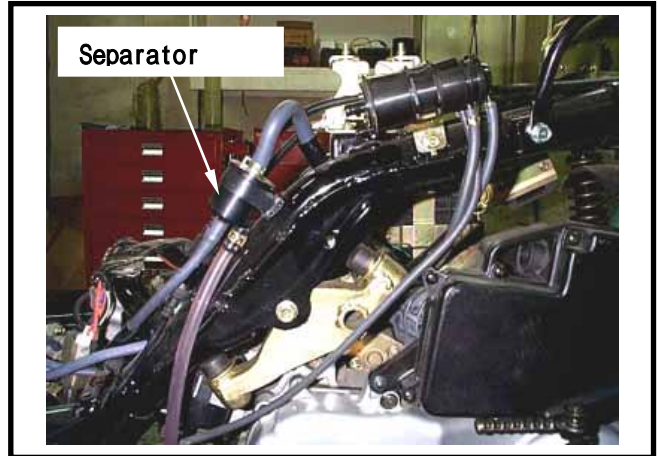

SPARK PLUG

Recommended spark plug: CR8E
Remove trunk.
Remove central cover.
Remove spark plug cap.
Clean dirt around the spark plug hole.
Remove spark plug.
Measure spark plug gap.
Spark plug gap : 0.8~0.9 mm
Carefully bend ground electrode of the plug to adjust the gap if necessary.
Hold spark plug washer and install the spark plug by screwing it.
Tighten the plug by turning 1/2 turn more with plug socket after installed.
Connect spark plug cap.

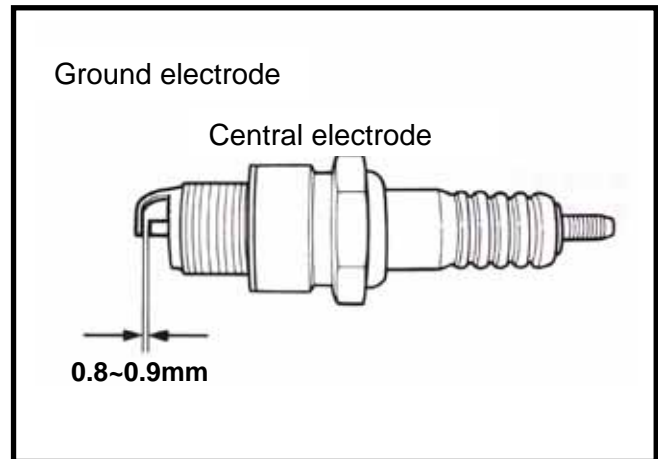

VALVE CLEARANCE

Caution

Checks and adjustment must be performed when the engine temperature is below 35°C.

Remove trunk.
Remove central cover.
Remove valve adjustment cap.
Remove cylinder head side cover.

Turn camshaft bolt in C.W. direction and let the "T" mark on the camshaft sprocket align with cylinder head mark so that piston is placed at TDC position in compression stroke.

Caution

Do not turn the bolt in C.C.W. direction to prevent from camshaft bolt looseness.

Valve clearance inspection and adjustment.
Check & adjust valve clearance with feeler gauge.

Valve clearance (IN/EX): 0.12 ± 0.02 mm
Loosen fixing nut and turn the adjustment nut for adjustment.

Caution

Re-check the valve clearance after tightened the fixing nut.

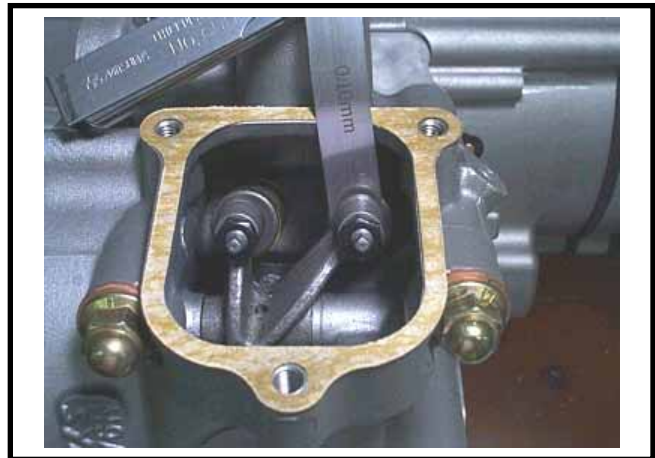

CARBURETOR IDLING SPEED ADJUSTMENT

Caution

Inspection & adjustment for idle speed have to be performed after all parts in engine that needed adjustment have been adjusted. Idle speed check and adjustment have to be done after engine is being warm up. (It is enough that operates engine from stop to running for 10 minutes.)

Park the motorcycle with main stand and warm up engine.
 Connect tachometer (the wire clamp of tachometer is connected to the high tension cable).
 Open carburetor cover from the trunk.
 Turn the throttle valve stopper screw to specified idle speed.
Specified idle speed: 1800 ± 100 rpm

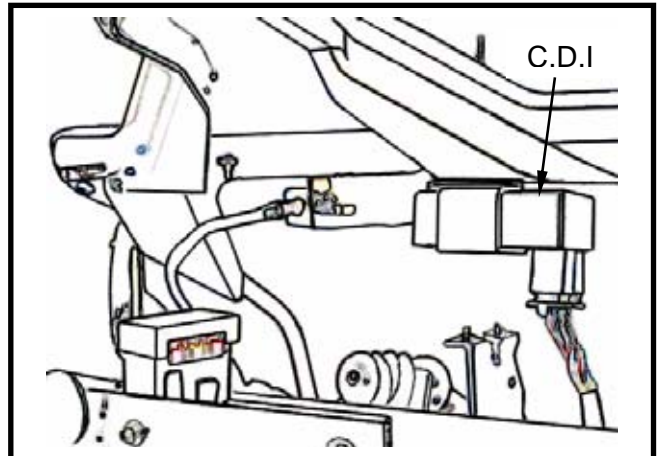
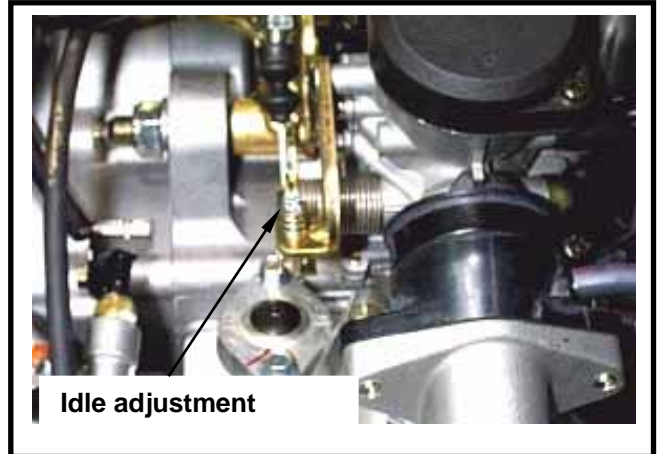

IGNITION SYSTEM

Caution

C.D.I ignition system is set by manufacturer so it can not be adjusted. Ignition timing check procedure is for checking whether CDI function is in normal or not.

Remove right side cover.
 Remove ignition timing hole cap located in front upper side of engine right cover.
 Connect tachometer and ignition lamp.
 Start engine.
 As engine in idle speed: 1000 rpm, aim at the mark "F" with the ignition lamp. Then, it is means that ignition timing is correct.
 Increase engine speed to 6000 rpm to check ignition advance degree. If indent is located within the ignition advance degrees, it is means that the ignition advance degree is in normal.
 If ignition timing is incorrect, check CDI set, pulse rotor and pulse generator. Replace it if malfunction of these parts is found.

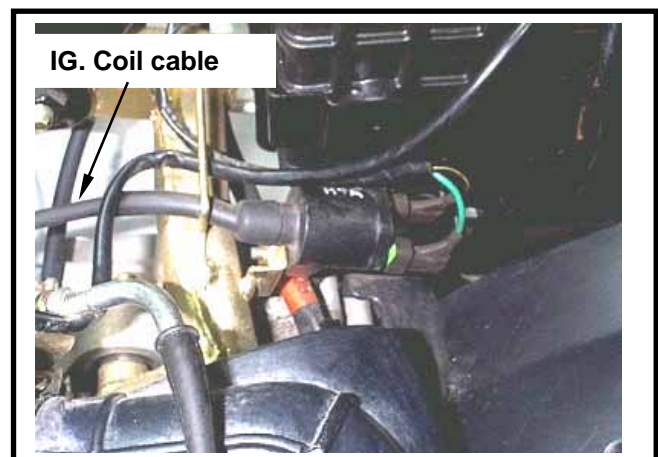

CYLINDER COMPRESSSION PRESSURE

Warm up engine.
Turn off the engine.
Remove the trunk.
Remove the central cover.
Remove spark plug cap and spark plug.
Install compression gauge.
Full open the throttle valve, and rotate the engine by means of starter motor.



Caution

Rotate the engine until the reading in the gauge no more increasing.
Usually, the highest pressure reading will be obtained in 4~7 seconds.

Compression pressure: $12 \pm 2 \text{ Kg/cm}^2$

Check following items if the pressure is too low:

- Incorrect valve clearance.
- Valve leaking.
- Cylinder head leaking, piston, piston ring and cylinder worn out.

If the pressure is too high, it means carbon deposits in combustion chamber or piston head.

DRIVING BELT

Remove left side cover.
Remove mounting bolt located under air cleaner.
Remove 9 bolts of the engine left side cover and the cover.
Check if the belt is crack or worn out.
Replace the belt if necessary or in accord with the periodical maintenance schedule to replace it.

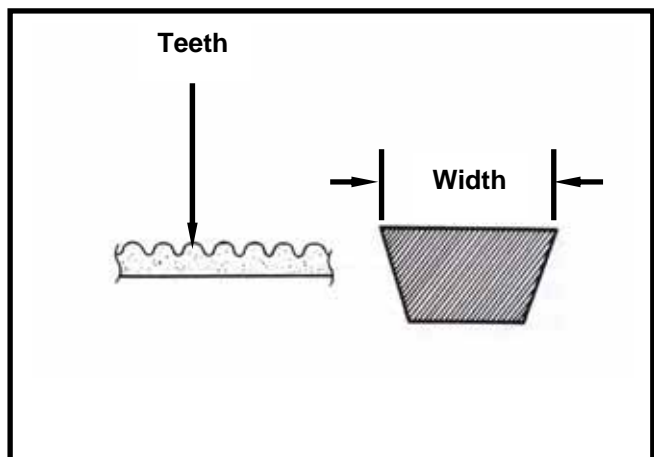
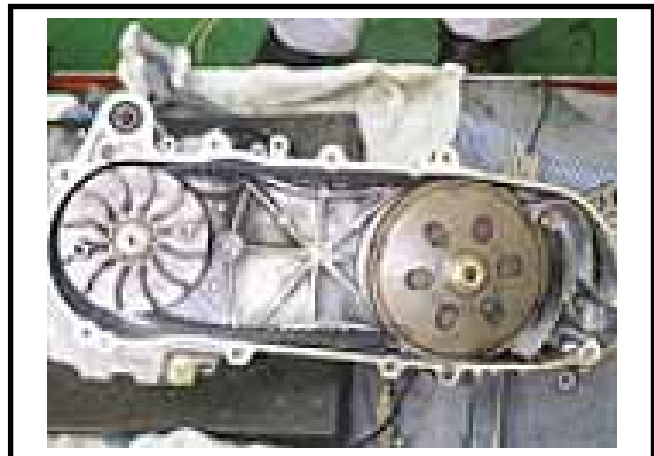

BRAKE SYSTEM (FRONT/REAR DISK BRAKE)

Free play of front/rear brake: 10~20 mm

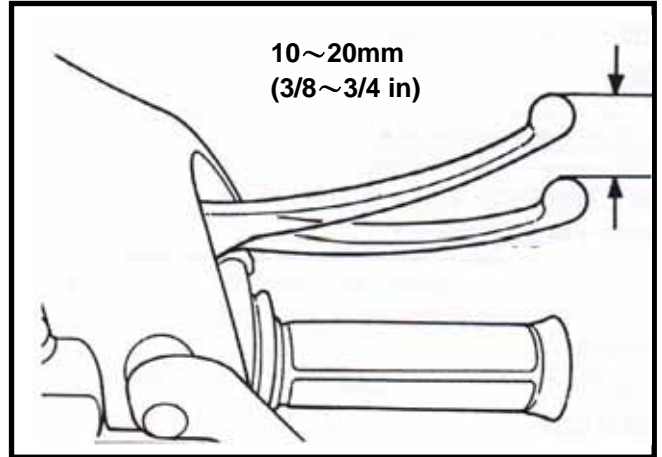

BRAKE SYSTEM HOSE

Make sure the brake hoses for corrosion or leaking oil.

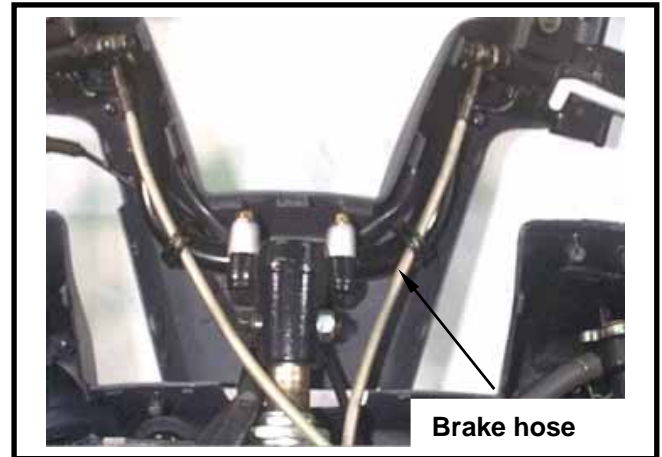

BRAKE FLUID

Check brake fluid level in the brake fluid reservoir. If the level is lower than the LOWER limit, add brake fluid to UPPER limit. Also check brake system for leaking if low brake level found.

Caution

In order to maintain brake fluid in the reservoir in horizontal position, do not remove the cap until handle bar stop. Do not operate the brake lever after the cap had been removed. Otherwise, the brake fluid will spread out if operated the lever. Do not mix non-compatible brake fluid together.

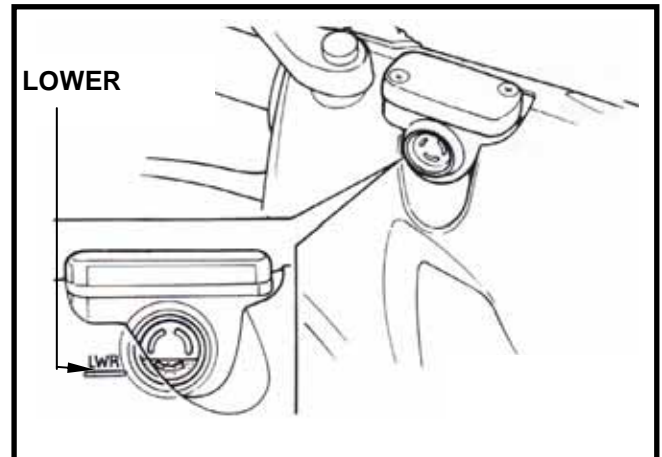

FILLING OUT BRAKE FLUID

Tighten the drain valve, and add brake fluid. Operate the brake lever so that brake fluid contents inside the brake system hoses.

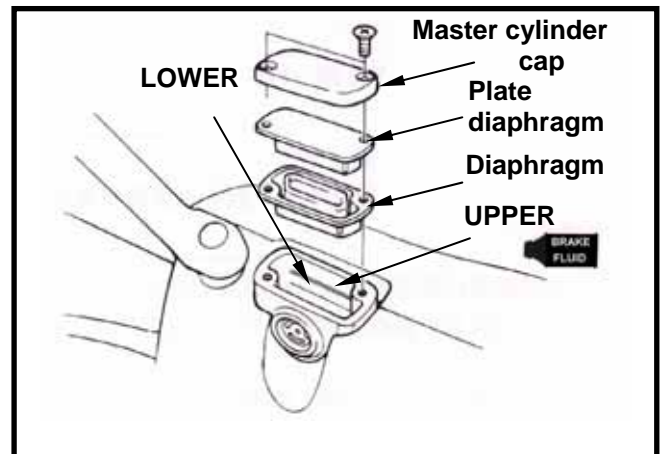

AIR BLEED OPERATION

Connect a transparent hose to draining valve. Hold the brake lever and open air bleeding valve. Perform this operation alternative until there is no air inside the brake system hoses.

Caution

Before closing the air bleed valve, do not release the brake lever.

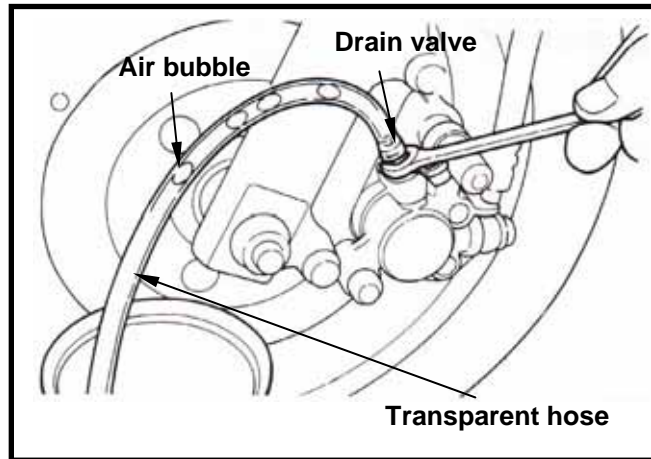

ADDED BRAKE FLUID

Add brake fluid to UPPER limit lever. Recommended brake fluid: DOT3 or DOT4 WELL RUN brake fluid.

Caution

Never mix or use dirty brake fluid to prevent from damage brake system or reducing brake performance.

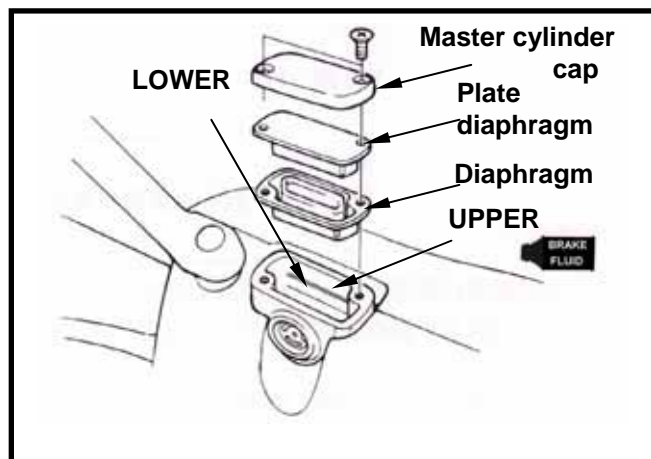

BRAKE LINING WEAR

The indent mark on brake lining is the wear limitation. Replace the brake lining if the wear limit mark closed to the edge of brake disc.

Caution

It is not necessary to remove brake hose when replacing the brake lining.

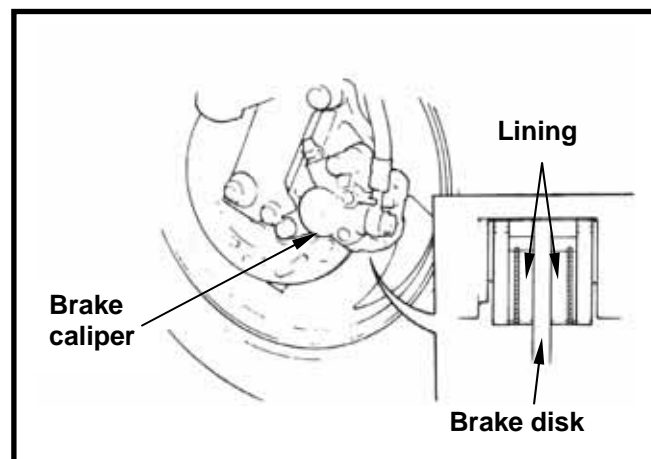

Remove the brake clipper bolt, and take out the clipper.

Caution

Do not operate the brake lever after the clipper removed to avoid clipping the brake lining.

Pry out the brake lining with a flat driver if lining is clipped.

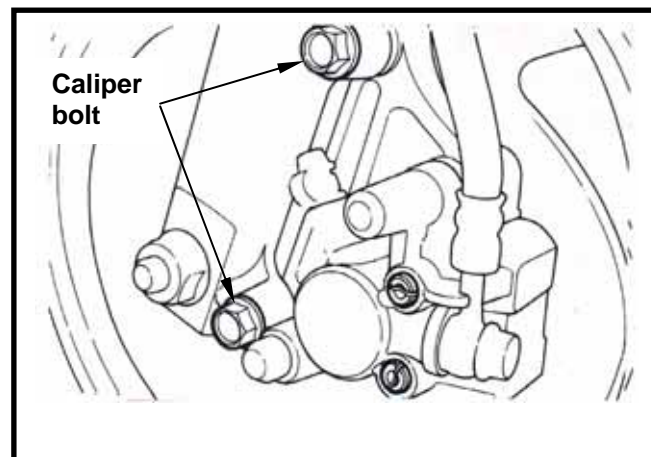

Remove brake lining bolt.
Take out the lining.

Caution

In order to maintain brake power balance, the brake lining must be replaced with one set.

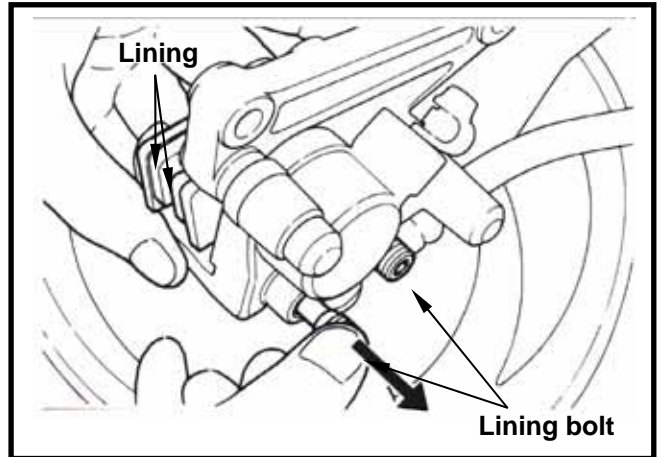

BRAKE LAMP SWITCH/STARTING INHIBITOR SWITCH

The brake lamp switch is to light up brake lamp as brake applied.
Make sure that electrical starter can be operated only under brake applying.

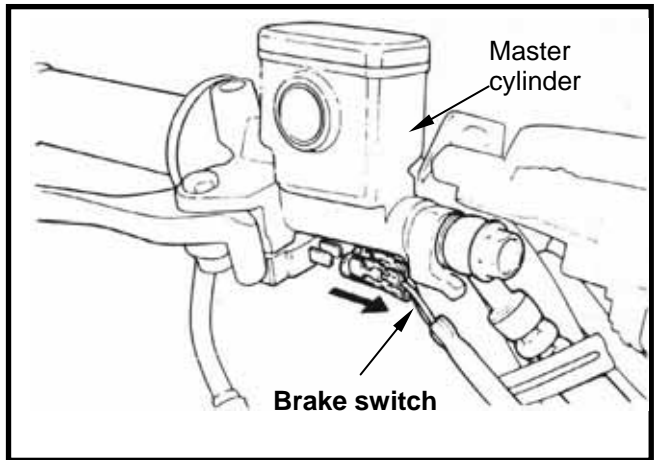

HEADLAMP BEAM DISTANCE

Turn on main switch
Headlamp beam adjustment. Turn the headlamp adjustment screw with driver to adjust headlamp beam high.

Caution

To adjust the headlamp beam follows related regulations.

Warning

Improper headlamp beam adjustment will make in coming driver dazzled or insufficient lighting.

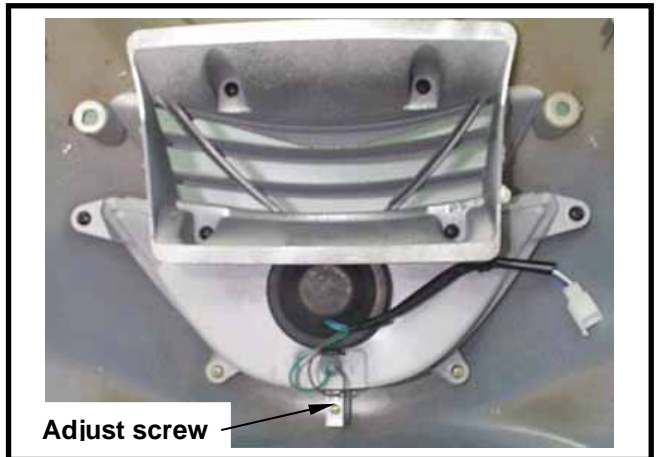

CLUTCH DISC WEAR

Run the motorcycle and increase throttle valve opening gradually to check clutch operation.
If the motorcycle is in forward moving and shaking, check clutch disc condition. Replace it if necessary.



SIDE STAND

Check side stand spring for damage or looseness.

Press down side stand and pull it with spring gauge. If gauge reading is over 2 kg, it means that the spring capacity is in normal.

Check if side stand set is operated smoothly. Make sure that side stand is no bending or deformation.

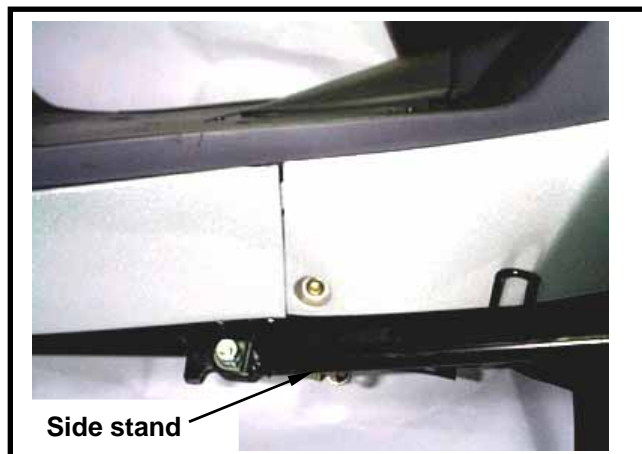

SHOCK ABSORBER

Warning

Do not ride the motorcycle with poor shock absorber.

Looseness, wear or damage shock absorber will make poor stability and drive-ability.

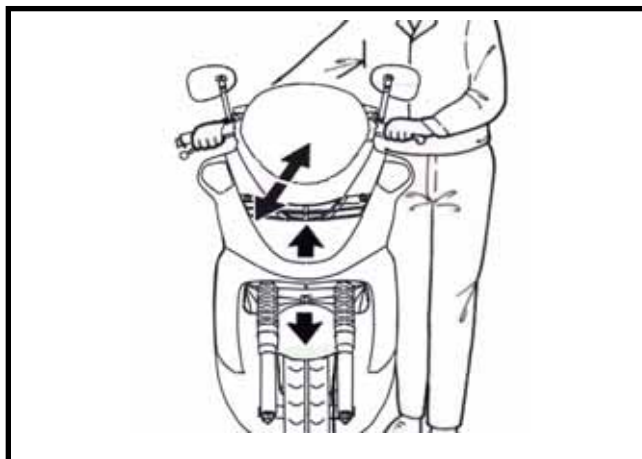

Front shock absorber

Press down the front shock absorber for several times to check its operation.

Check if it is damaged.

Replace relative parts if damage is found.

Tighten all nuts and bolts.

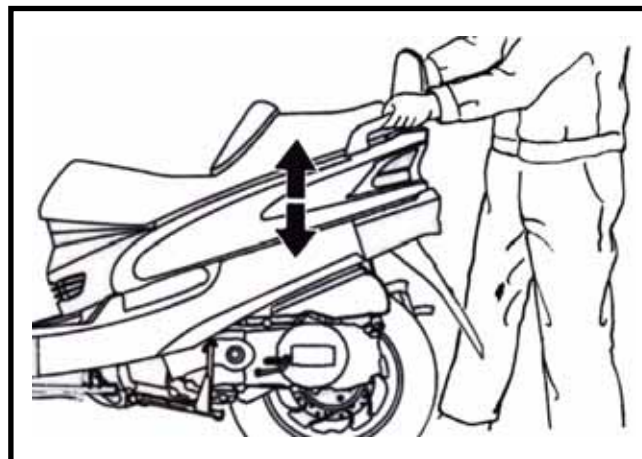

Rear Shock absorber

Press down the front shock absorber for several times to check its operation.

Check if it is damaged.

Replace relative parts if damage is found.

Park motorcycle with main stand.

Turn the rear wheel forcefully and check if engine bracket bushing is worn out.

Replace the bushing if looseness is found.

Tighten all nuts and bolts.

NUTS, BOLTS TIGHTNESS

Perform periodical maintenance in accordance with the Periodical Maintenance Schedule.

Check if all bolts and nuts on the frame are tightened securely.

Check all fixing pins, snap rings, hose clamps, and wire holders for security.

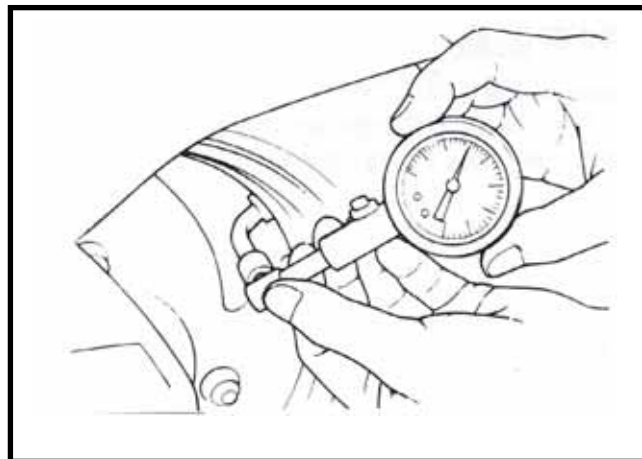

WHEEL/TIRE

Caution

Tire pressure check should be done as cold engine.

Check if tire surface is ticked with nails, stones or other materials.

Appointed tire pressure

Tire size		Front tire	Rear tire
Tire pressure as cold engine (Kg/cm ²)	Load for under 90 Kg	1.5	2.0
	Full loaded	1.5	2.5

Check if front and rear tires' pressure is in normal.

Measure tire thread depth from tire central surface.

Replace the tire if the depth is not come with following specification:

Front tire: 1.5 mm

Rear tire: 2.0 mm

STEERING HANDLE TOP BEARING

Caution

Check all wires and cables if they are interfered with the rotation of steering handle bar.

Lift the front wheel out of ground.

Turn handle from right to left alternative and check if turning is smoothly.

If handle turning is uneven and bending, or the handle can be operated in vertical direction, then adjust the handle top bearing.

Precautions in operation..... 3-2	Oil pump disassembly.....3-4
Troubleshooting..... 3-2	Oil pump inspection.....3-5
Engine oil..... 3-3	Oil pump re-assembly.....3-5
Engine oil strainer clean..... 3-3	Oil pump installation.....3-6
Oil pump removal..... 3-4	Gear oil.....3-7

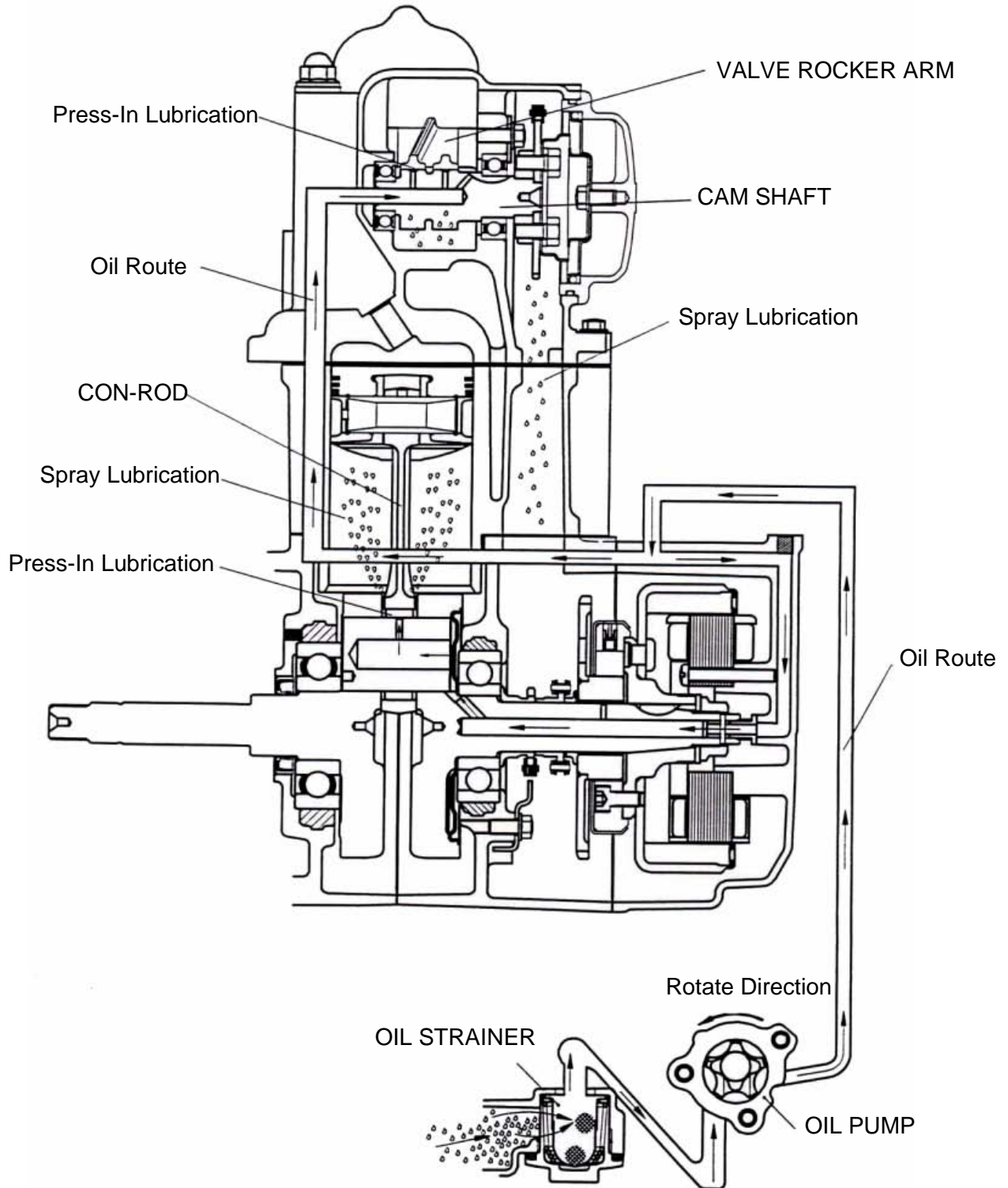

PRECAUTIONS IN OPERATION

General Information:

- This chapter contains maintenance operation for the engine oil pump and gear oil replacement.

Specifications

Engine oil quantity	Disassembly: 1000 c.c. Change: 800 c.c.
Gear oil	Disassembly: 110 c.c. Change: 100 c.c.
Oil	Oil viscosity SEA 10W-30 (Recommended King serial oils)
Gear oil	Gear oil viscosity SEA 85W-140 (Recommended SYM Hypoid gear oils)

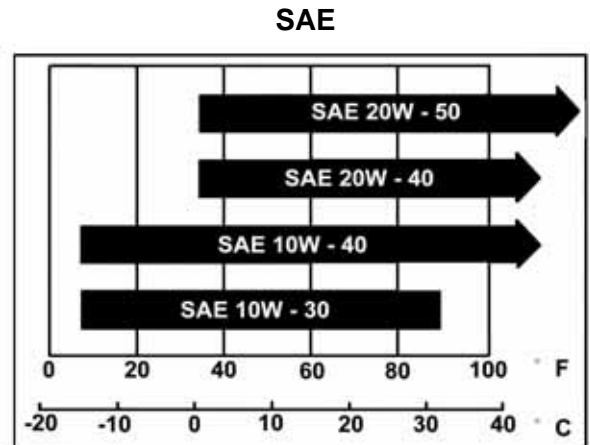

Items		Standard (mm)	Limit (mm)
Oil pump	Inner rotor clearance	0.15	0.20
	Clearance between outer rotor and body	0.15~0.20	0.25
	Clearance between rotor side and body	0.04~0.09	0.12

Torque value oil strainer	1.3~1.7 Kgf-m
Gear oil drain plug	1.1~1.4 Kgf-m
Gear oil inspection bolt	1.1~1.4 Kgf-m
Oil pump connection bolt	0.8~1.2 Kgf-m

TROUBLESHOOTING

Low engine oil level

- Oil leaking
- Valve guide or seat worn out
- Piston ring worn out

Dirty oil

- No oil change in periodical
- Cylinder head gasket damage
- Piston ring worn out

Low oil pressure

- Low engine oil level
- Clogged in oil strainer, circuits or pipes
- Oil pump damage

ENGINE OIL

Turn off engine, and park the motorcycle in flat surface with main stand.

Check oil level with oil dipstick

So not screw the dipstick into engine as checking.

If oil level is nearly low level, fill out recommended oil to upper level.

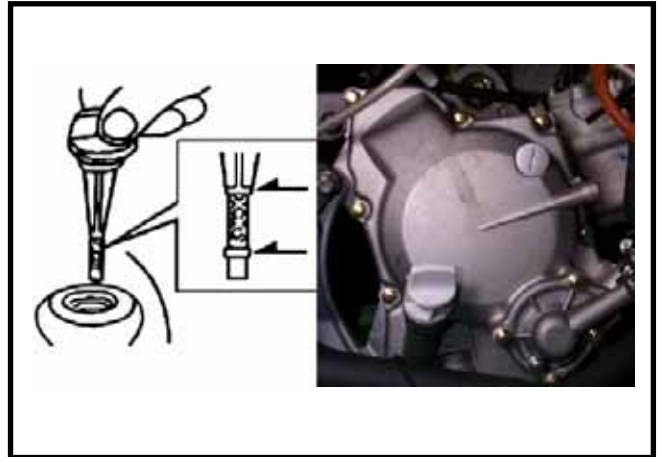

Oil Change

Caution

Drain oil as engine warmed up so that make sure oil can be drained smoothly and completely.

Place a oil pan under the motorcycle, and remove oil drain bolt.

After drained, make sure washer can be re-used.

Install oil drain bolt.

Torque value: 1.1~1.5 Kgf-m

Fill out engine oil (oil viscosity SEA 10W-30).

Recommended using King serial oil.

Engine oil capacity: 0.8L when replacing



Install dipstick, start the engine for running several minutes.

Turn off engine, and check oil level again.

Check if engine oil leaks.



Engine Oil Strainer Clean

Drain engine oil out.

Remove oil strainer and spring.

Clean oil strainer.

Check if O-ring can be re-used.

Install oil strainer and spring.

Install oil strainer cap.

Torque value: 1.3~1.7 Kgf-m

Add oil to crankcase (oil viscosity SAE 10W-30)

Recommended using King serial oil.

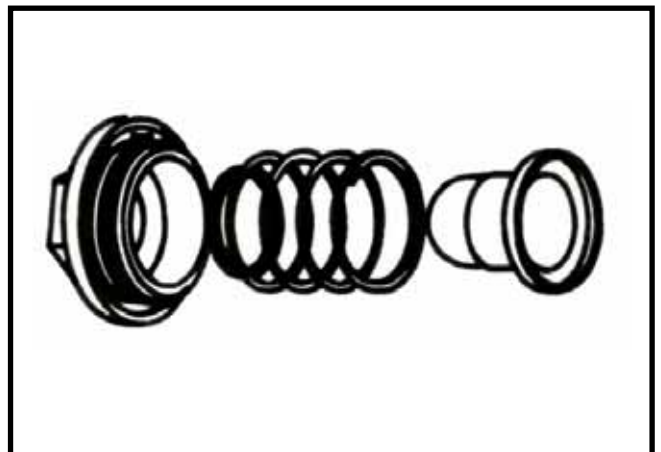

Oil Pump Removal

Remove generator and starting gear.

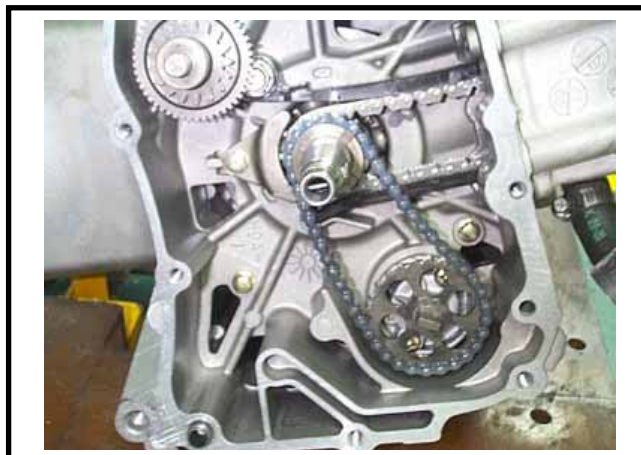

Remove snap ring and take out oil pump driving chain and sprocket.

Torque value: 0.8~1.2 Kg-m

Make sure that pump shaft can be rotated freely.



Remove 2 bolts on the oil pump, and then remove oil pump.

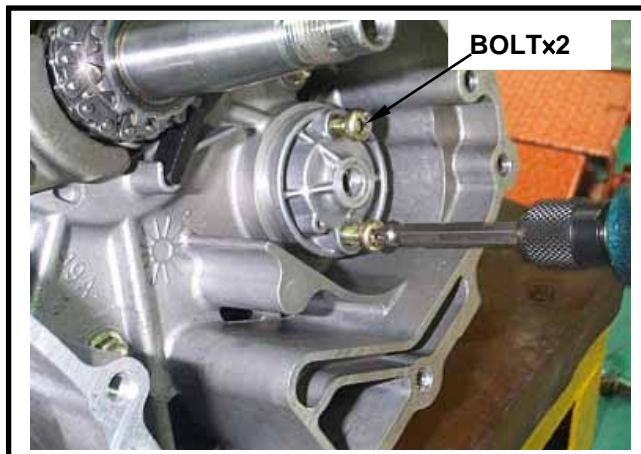

Oil Pump Disassembly

Remove the screws on oil pump cover and disassemble the pump as illustration shown.

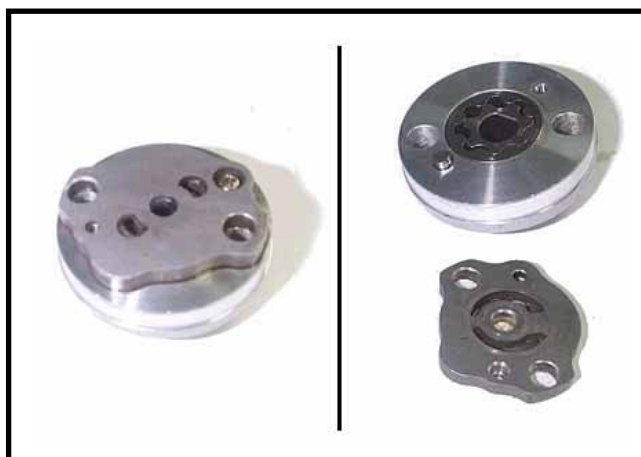

Oil Pump Inspection

Check the clearance between oil pump body and outer rotor.

Limit: 0.25 mm



Check clearance between inner and outer rotors.

Limit: 0.20 mm



Check clearance between rotor side face and pump body

Limit: 0.12 mm



Oil Pump Re-assembly

Install inner and outer rotors into the pump body
Align the indent on driving shaft with that of inner rotor. Install the driving shaft
Install fixing pin

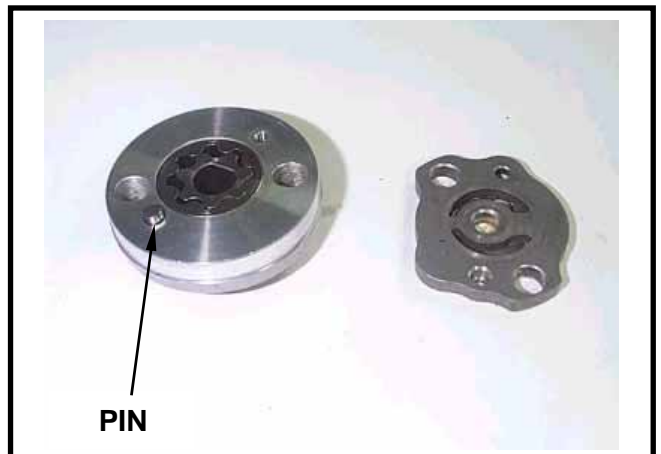

3. LUBRICATION SYSTEM



Install the oil pump cover and fixing pin properly



Tighten screw
Make sure that oil pump shaft can be rotated freely.

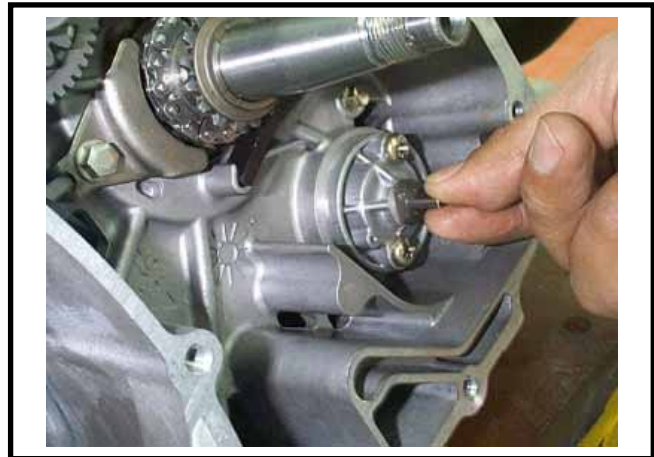

Oil Pump Installation

Install the oil pump, and then tighten bolts.

Torque value: 0.8~1.2 Kg-m

Make sure that oil pump shaft can be rotated freely.

Install oil pump driving chain and sprocket, and then install snap ring onto oil pump shaft.



Install starting gear and generator.



Gear Oil

Oil level inspection

Park the motorcycle on flat surface with main stand.

Turn off engine and remove oil inspection bolt.



Gear lubrication oil quantity has to be measured with measure device.

If oil level is too low, add gear oil.

Recommended using King serial oils.

Install oil inspection bolt.

Torque value: 1.0~1.4 Kgf-m



Gear Oil Change

Remove oil level inspection bolt.

Remove drain plug and drain oil out.

Install the drain plug after drained.

Torque value: 1.0~1.4 Kgf-m

Make sure that the drain plug washer can be re-used.

Add oil to specified quantity from the inspection hole.

Gear Oil Quantity: 100 c.c. when replacing

Make sure that the bolt washer can be re-used, and install the bolt.

Start engine and run engine for 2-3 minutes.

Turn off engine and make sure that oil level is in correct level.

Make sure that no oil leaking.

NOTES

Precautions in operation	4-2	Float chamber.....	4-7
Trouble diagnosis	4-3	Installation of carburetor	4-8
Air cut-off valve.....	4-4	Adjustment of pilot screw	4-8
Auto by-starter	4-4	Fuel tank	4-9
Carburetor removal.....	4-5	Air cleaner.....	4-10
Vacuum chamber	4-5		

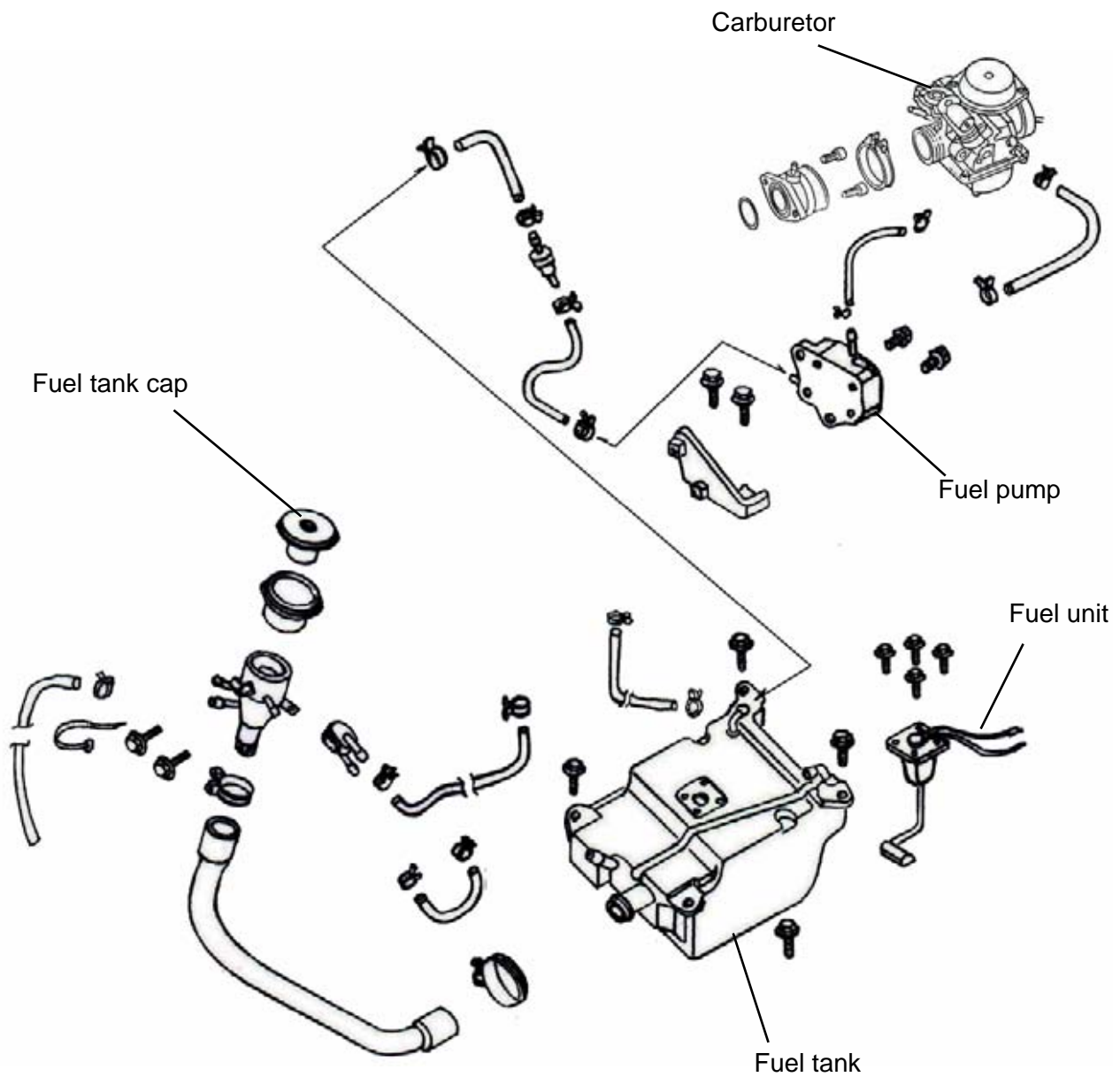

PRECAUTIONS IN OPERATION

General Information

Warning

Gasoline is a low ignition point and explosive materials, so always work in a well-ventilated place and strictly prohibit flame when working with gasoline.

Cautions

- Do not bend off throttle cable. Damaged throttle cable will make unstable drive-ability.
- When disassembling fuel system parts, pay attention to O-ring position, replace with new one as re-assembly
- There is a drain screw in the float chamber for draining residual gasoline.
- Do not disassemble auto by-starter and air cut valve arbitrarily.

Specification

Item	LA12W	LA15W	LA18W
Carburetor diameter	24 mm	24 mm	25 mm
I.D. number	CVK039	CVK034	CVK066
Fuel level	20.5 mm	20.5 mm	20.5 mm
Main injector	#108	#105	#108
Idle injector	#35	#35	#35
Idle speed	1800±100 rpm	1800±100 rpm	1800±100 rpm
Throttle handle clearance	2~6 mm	2~6 mm	2~6 mm
Pilot screw	2 1/4 turns	2 1/2 turns	1 1/2 turns

Torque value

Fuel valve tightening nut: 1.5~2.0Kgf-m

Tool

Special service tools

Vacuum/air pressure pump

General service tool

Fuel level gauge

TROUBLE DIAGNOSIS**Poor engine start**

- No fuel in fuel tank
- Clogged fuel tube
- Too much fuel in cylinder
- No spark from spark plug(malfunction of ignition system)
- Clogged air cleaner
- Malfunction of auto by-starter
- Malfunction of throttle operation
- Malfunction of purge control valve

Stall after started

- Malfunction of auto by-starter
- Incorrect ignition timing
- Malfunction of carburetor
- Dirty engine oil
- Air existing in intake system
- Incorrect idle speed
- Malfunction of purge control valve

Rough idle

- Malfunction of ignition system
- Incorrect idle speed
- Malfunction of carburetor
- Dirty fuel

Intermittently misfire as acceleration

- Malfunction of ignition system

Late ignition timing

- Malfunction of ignition system
- Malfunction of carburetor

Power insufficiency and fuel consuming

- Fuel system clogged
- Malfunction of ignition system

Mixture too lean

- Clogged fuel injector
- Vacuum piston stick and closed
- Malfunction of float valve
- Fuel level too low in float chamber
- Clogged fuel tank cap vent
- Clogged fuel filter
- Obstructed fuel pipe
- Clogged air vent hose
- Air existing in intake system

Mixture too rich

- Clogged air injector
- Malfunction of float valve
- Fuel level too high in float chamber
- Malfunction of auto by-starter
- Dirty air cleaner

AIR CUT-OFF VALVE

Inspection

Disconnect vacuum hose and air vent hose from the air cut-off valve.

Connect a hose from vacuum hose connector to vacuum pump.

Connect air pump to air vent hose.

Apply with specified vacuum to air cut-off valve.

Vacuum value: 420~500 mm-Hg

Pump compressed air from air pump to air vent hose.

Caution

The vacuum can not be over 600 mm-Hg. Or the air cut-off will be damaged.

If the valve is in normal, it will restrict air-flow. If air-flow is no restrict, replace carburetor assembly.



AUTO BY-STARTER

Inspection

Turn off engine and waiting for over 10 minutes for cooling.
Check resistance across the two terminals of the auto by-starter.

Resistance value: Max. 10Ω (Measured after engine stopped for more than 10 minutes)

Replace the auto starter with a new one if resistance value exceeds standard.

Remove carburetor, allow it to cool off for 30 minutes.

Connect a pressure tester from air pump.

Connect by-starter circuit.

Pump compressed air to the circuit.

Replace the auto by-starter if the circuit clogged.

Connect battery posts (12V) to starter's connectors. After 5 minutes, test the by-starter circuit with compressed air. If air flows through the circuit, then, replace the starter.

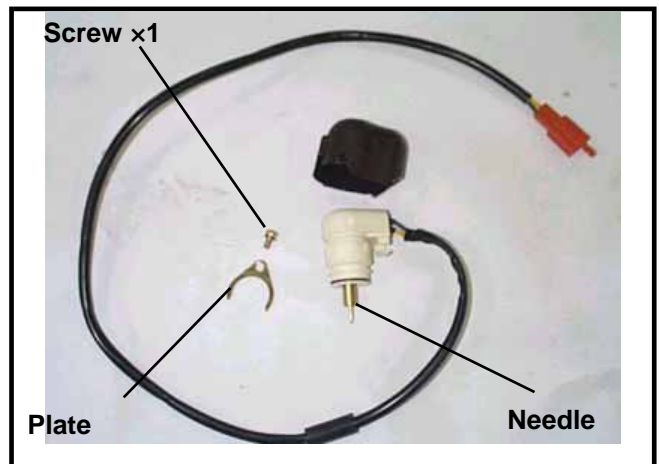
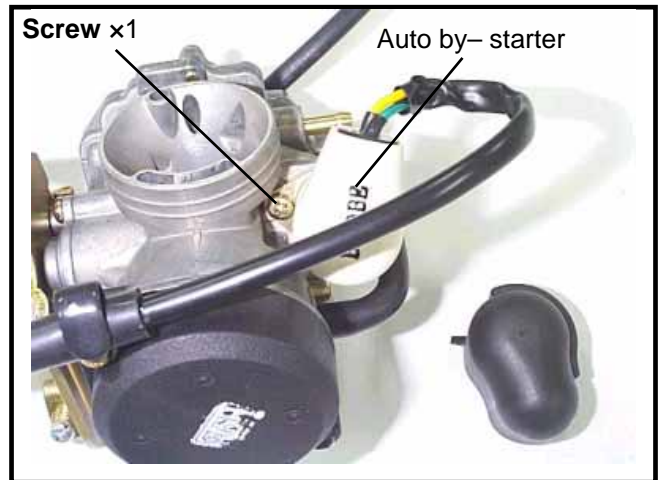

Removal

Remove fixing plate screw, and then remove the plate and auto by-starter from carburetor.

Valve inspection

Check if auto by-starter and valve needle for damage or wear out.

Installation

Install auto by-starter to the bottom of carburetor body.

Install fixing plate to the upper groove of auto by-starter, and install its flat surface to carburetor. Install screw and tighten it.



4. FUEL SYSTEM



Carburetor removal

Remove the luggage box.
Loosen the adjustment nut and fixing nut of throttle valve cable, and release the cable from carburetor.
Remove air cut-off valve hose.
Remove fuel pipe, vacuum hose.
Disconnect automatic by-starter connectors.
Release the clamp strip of carburetor isolation.
Release the clamp strip of air cleaner.

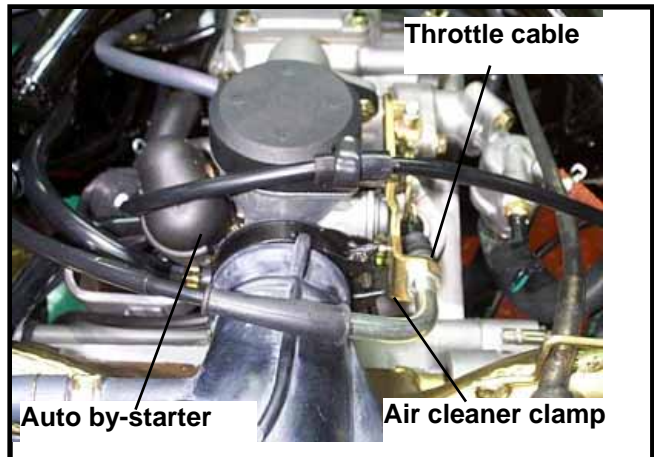

Vacuum chamber

Removal

Loosen drain screw, and drain out residual fuel in float chamber.
Remove 2 screws of vacuum chamber cover and the cover.



Remove compress spring and vacuum piston.



Check if the vacuum piston for wear out, crack or other damage.
Check if the diaphragm for damage or crack.

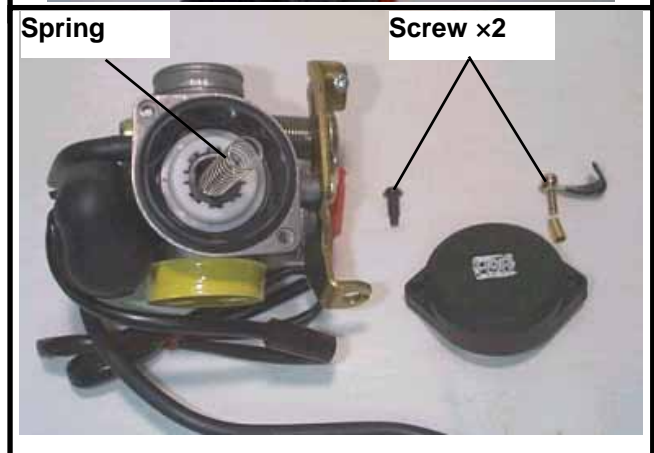

Installation

Install needle, spring and needle seat to vacuum piston.

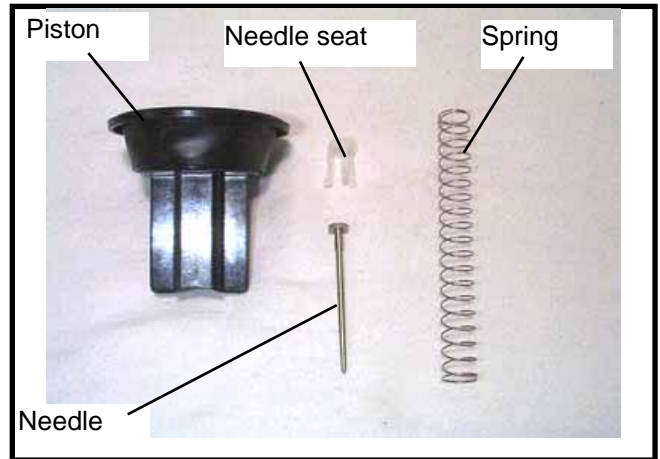

Install vacuum piston to carburetor body and align the indent on the diaphragm.

Install compress spring.



Install vacuum chamber cover and tighten 2 screws.

Caution

- Do not damage vacuum diaphragm.
- When tightening the vacuum chamber screw, hold down vacuum piston.



FLOAT CHAMBER

Disassembly

Remove 4 mounting screws and remove float chamber cover.
Remove the float pin and float.

Checking

Check float valve and valve seat for damage, blocking.
Check float valve for wearing, and check valve seat face for wear, dirt.

Caution

In case of worn out or dirt, the float valve and valve seat will not tightly close causing fuel level to increase and as a result, fuel flooding. A worn out or dirty float valve must be replaced with a new one.

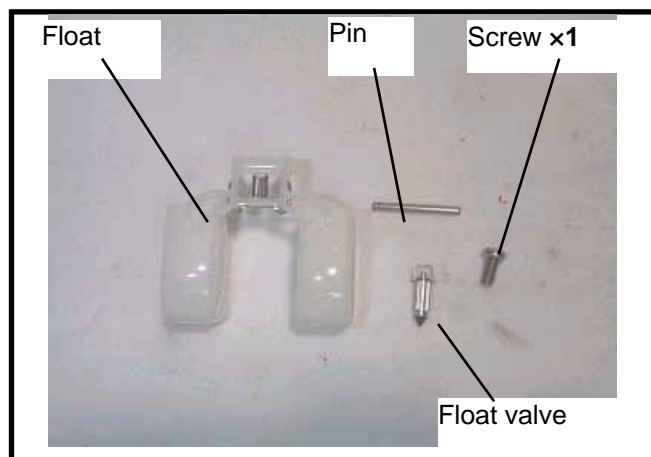
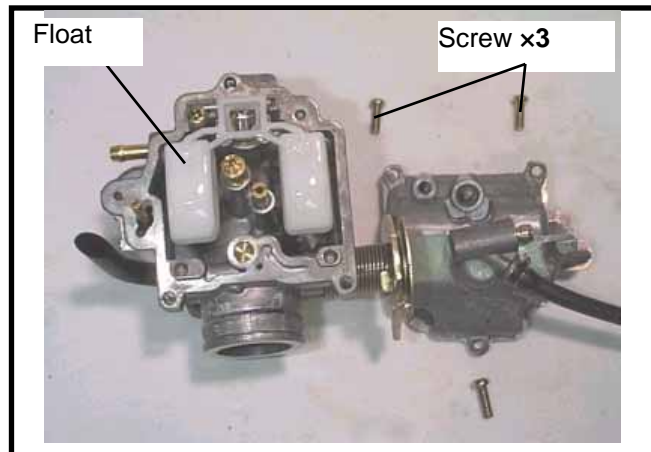

Remove main jet, fuel needle jet holder, needle jet, slow jet, pilot screw.

Caution

- Take care not to damage jets and adjust screw.
- Before removing adjustment screw, turn it all the way down and note the number of turns.
- Do not turn adjust screw forcefully to avoid damaging valve seat face.

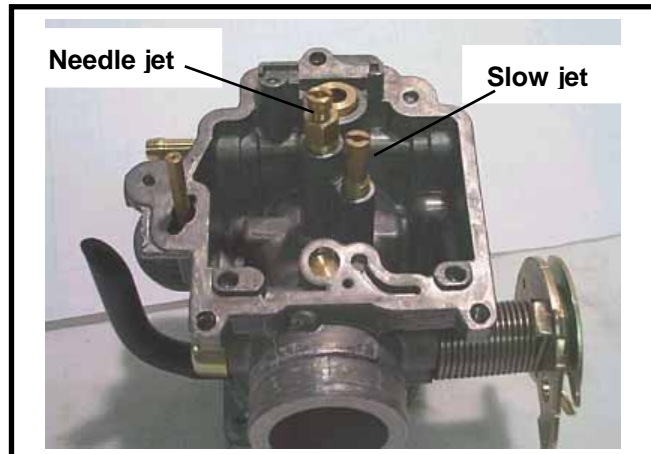

Clean jets with cleaning fluid. Then use compressed air to blow the dirt off.
Blow carburetor body passages with compressed air.

Caution

Remove vacuum chamber and air cut-off valve as a set.

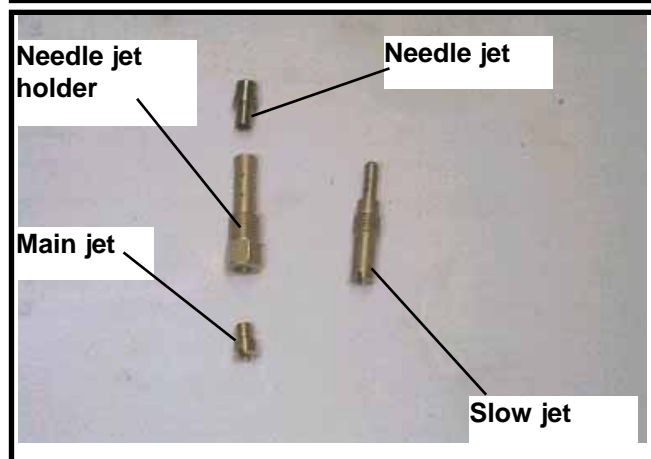

Assembly

Install main jet, fuel needle jet holder, fuel needle jet slow jet and pilot screw.

⚠ Caution

Set the pilot screw in according to number of turns noted before it was removed.

Install the float valve, float, and float pin.

Checking fuel level

⚠ Caution

- Check again to ensure float valve, float for proper installation.
- To ensure correct measurement, position the float meter in such a way so that float chamber face is vertical to the main jet.

Fuel level: 20.5 mm

Installation of carburetor

Install carburetor in the reverse order of removal. Following adjustments must be made after installation.

- Throttle cable adjustment.
- Idle adjustment

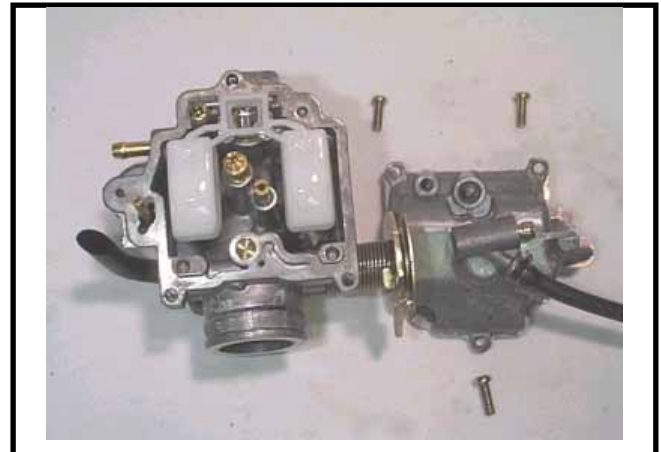
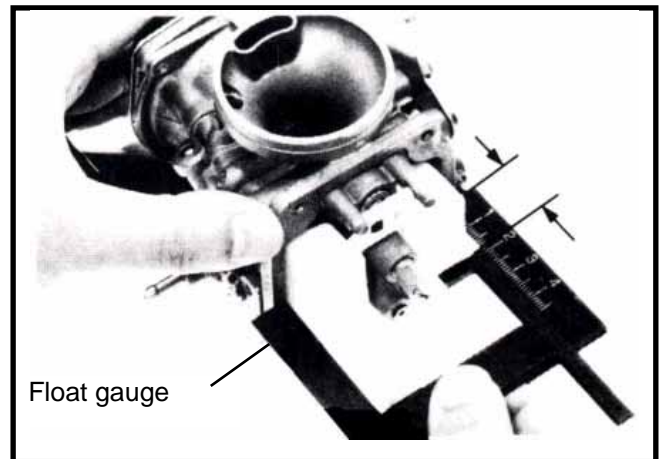
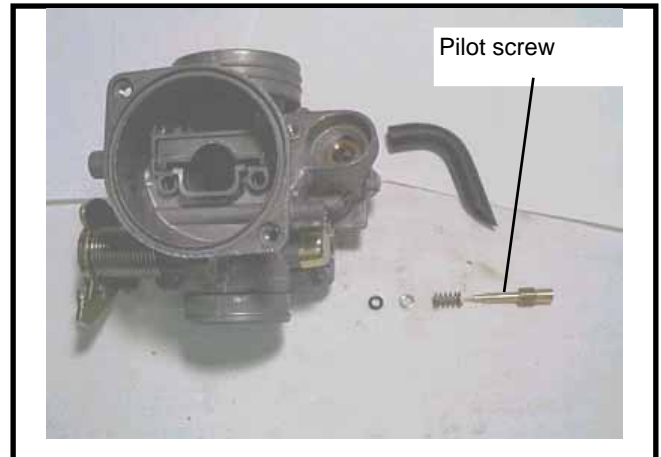

Adjustment of pilot screw

Caution

- Pilot screw was set at factory, so no adjustment is needed. Note the number of turns it takes to screw it all the way in for ease of installation.
- The main stand must be used to support the motorcycle to perform the adjustments.

Use a tachometer when adjusting engine RPM. Screw in adjustment screw gently, then back up to standard turns.

Standard turns:

LA12W : 2 ± 1/4 turns

LA15W : 2 ± 1/2 turns

LA18W : 1 ± 1/2 turns

Caution

Do not screw in forcefully to avoid damaging screw seat face.

Warm up engine, adjust the stopper screw of throttle valve to standard RPM.

Idle speed rpm: 1800 ± 100 rpm

Connect the hose of exhaust analyzer to exhaust front end. Press test key on the analyzer. Adjust the pilot screw and read CO reading on the analyzer

CO standard value: 1.0~1.5 %

Accelerate in gradual increments, make sure rpm and CO value are in standard value after engine running in stable. If rpm and CO value fluctuated, repeat the procedures described above for adjusting to standard value.

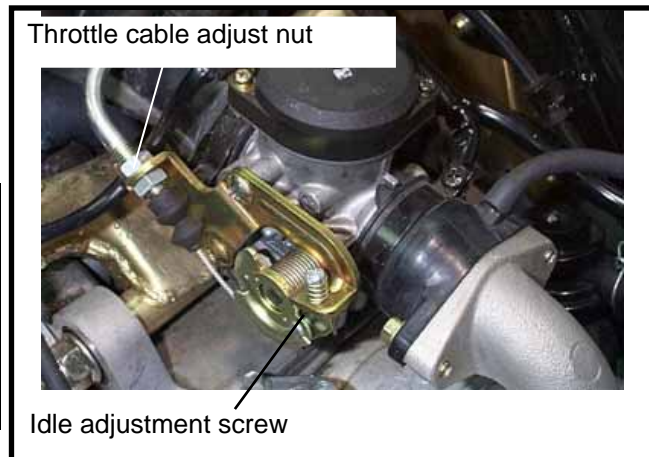

FUEL TANK

Fuel unit removal

Open the seat.
 Remove the luggage box (6 bolts and 1 screw).
 Remove rear carrier (3 bolts).
 Remove rear bracket (2 bolts).
 Remove the rear central cover (4 screws).
 Remove the left and right pedals (1 bolt).
 Remove the left and right covers (4 bolts).
 Remove the central cover (6 screws).
 Remove the left & right body covers and the central upper cover (4 screws and 2 bolts).
 Remove pedal (4 bolts and 4 screws).
 Disconnect fuel unit connector.
 Remove fuel unit (4 screws).

Caution

- Do not bend the float arm of fuel unit
- Do not fill out too much fuel to fuel tank.

Fuel unit inspection (Refer to electrical equipment 17-15).

Fuel unit installation

Install the gauge in the reverse order of removal.

Caution

Do not forget to install the gasket of fuel unit or damage it.

Fuel tank removal

Open the seat.
 Remove the luggage box (6 bolts and 1 screw).
 Remove the rear central cover (4 screws).
 Remove the left and right pedals (1 bolt).
 Remove the left and right covers (4 bolts).
 Remove the central cover (6 screws).
 Remove pedal (4 bolts and 4 screws).
 Disconnect fuel unit connector.
 Remove fuel unit (4 screws).
 Remove fuel pump (2 bolts).
 Remove fuel tank bracket (4 bolts).
 Remove vacuum tube and fuel filter.
 Remove fuel tank

Installation

Install the tank in the reverse order of removal.

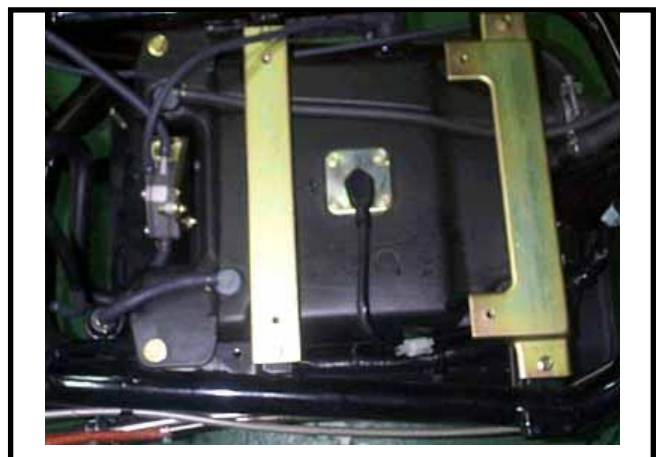
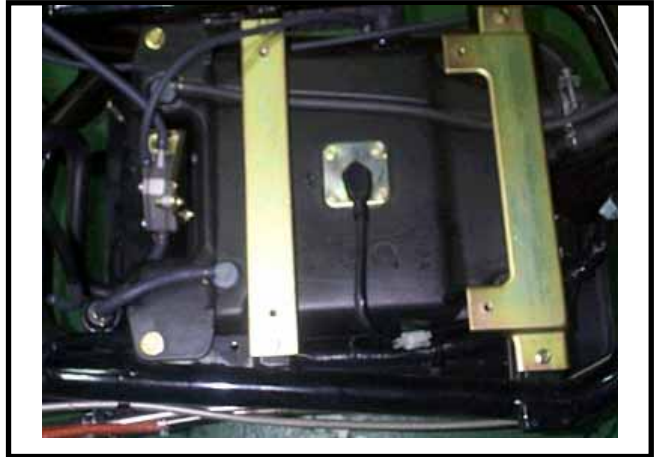

4. FUEL SYSTEM



AIR CLEANER

Open the seat.
Loosen the clamp strip of air cleaner.
Remove left cover (2 screws).
Remove mounting bolts for crankcase and gear box (2 bolts).
Remove air cleaner cap (8 screws).
Remove air cleaner set (4 screws).

Caution

The air cleaner element is made of paper so do not soap it into water or wash it with water.

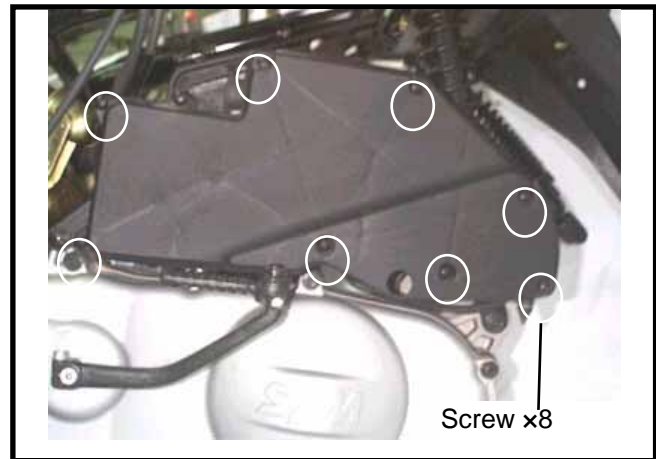

Precautions in Operation 5-1	Engine Mounting Bracket Installation5-6
Removal of Engine 5-2	Engine Installation5-6
Removal of Engine Mounting Bracket..... 5-5	

PRECAUTIONS IN OPERATION

General Information

- The engine has to be supported with special service tools that can be lifted or adjustable.
- The following parts can be serviced as engine mounted on frame.
- Carburetor.
- Cylinder head, cylinder, and piston.
- Driving pulley, driving belt, clutch, and driving disc assembly.
- Final gear reduction mechanism.

Specification

Item		Capacity
Engine oil capacity	Replacement	800 c.c.
	Disassembly	1000 c.c.
Gear oil capacity	Replacement	100 c.c.
	Disassembly	110 c.c.
Coolant capacity	Engine & radiator	780 c.c.
	Reservoir	420 c.c. AS indicator shown
	Total	1200 c.c.

Torque Value

Engine mounting bolt	4.0~5.0kgf-m
Engine hanger bolt	3.5~4.5kgf-m
Rear shock absorber connection bolt(under)	2.4~3.0kgf-m
Engine hanger stopper nut	1.8~2.2kgf-m
Engine bracket nut	4.0~5.0kgf-m

5. ENGINE REMOVAL



Removal of Engine

Open seat cushion.

Remove the luggage box (6 bolts and 1 screw).

Remove rear carrier (3 bolts).

Remove rear bracket (2 bolts).

Remove the rear central cover (4 screws).

Remove the left and right pedals (1 bolt).

Remove the left and right covers (4 screws).

Remove the central cover (6 screws).

Remove the left & right body covers and the central upper cover (4 screws and 2 bolts).

Remove battery negative (-) post.

Remove battery positive (+) post.

Remove ignition coil cable.

Disconnect the auto by-starter wire connector.

Disconnect A.C.G wire connectors.

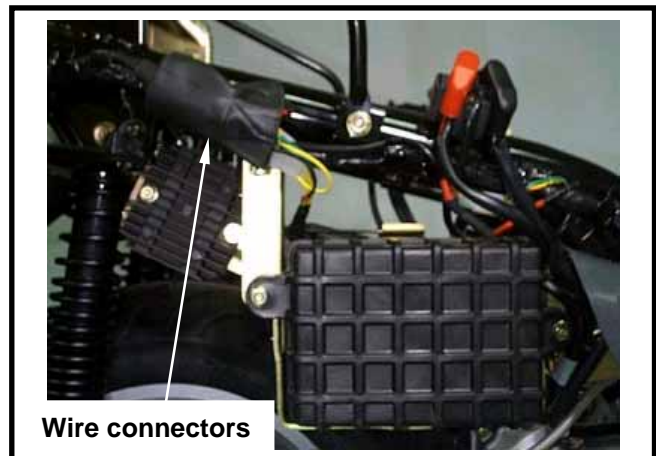

Remove starter motor wire from relay.



Remove spark plug cap.

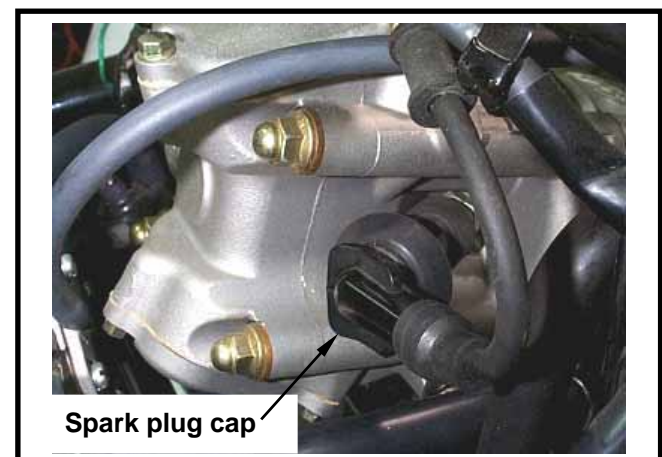

Remove fuel pipe, vacuum tube and throttle valve wire from carburetor.
Loosen the screw of air cleaner duct strip, and then remove the duct.



Remove water hose from water pump.
Remove the thermo-sensor wires.

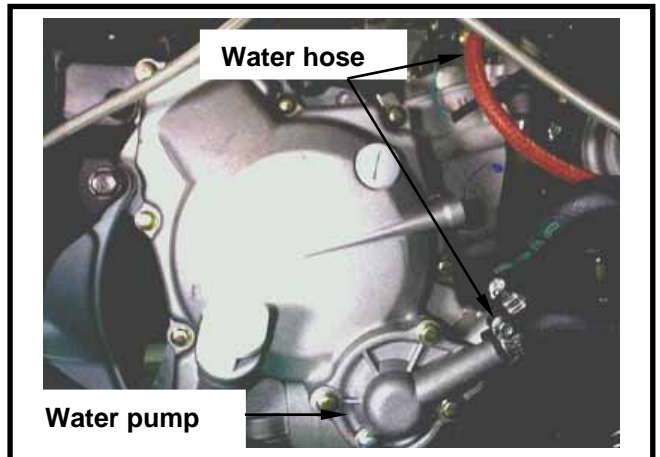

Remove the muffler (3 bolts, 2 nuts).

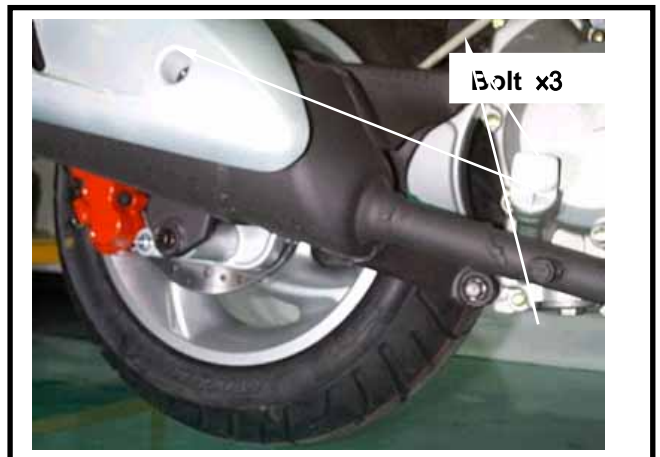

5. ENGINE REMOVAL



Remove brake hose bracket (1 bolt).
Remove rear brake calliper (2 bolts).

Caution

Do not operate brake lever after the clipper removed to avoid clipping the brake lining.

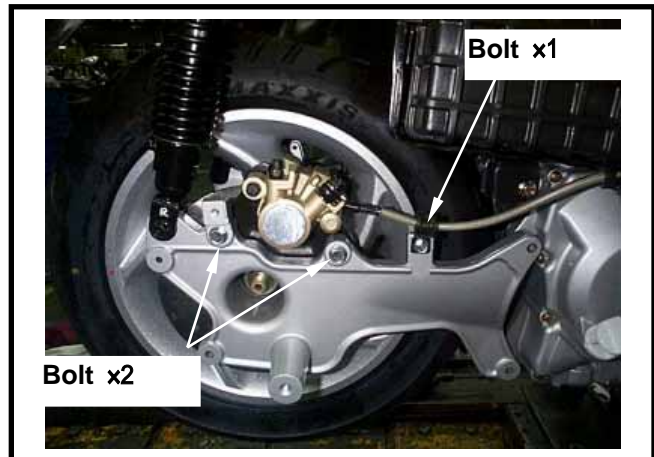

Remove the mounting bolt of right-rear shock absorber and the shock absorber.

Remove rear wheel mounting nut.

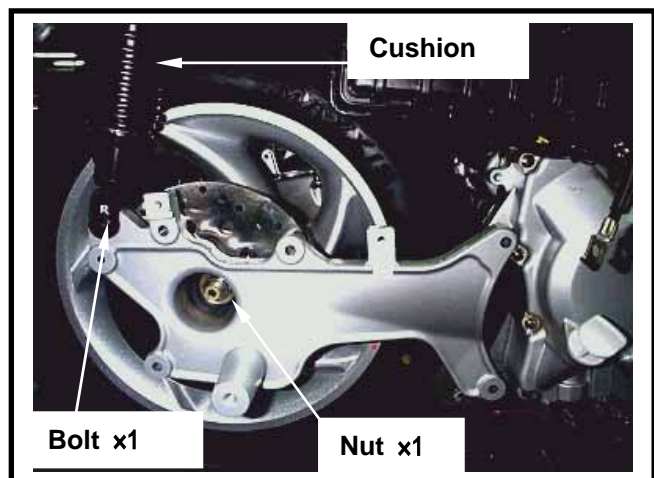

Remove swing arm.



Remove rear wheel.



Loosen the mounting screw of left crankcase duct, and then remove the duct.

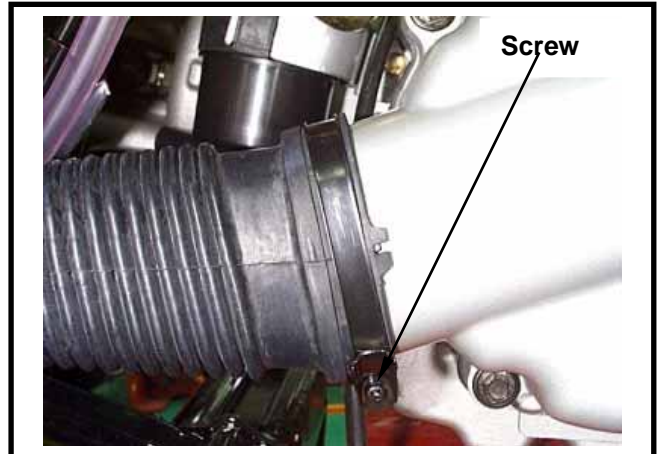

Remove the mounting bolts (2 bolts) of air cleaner.

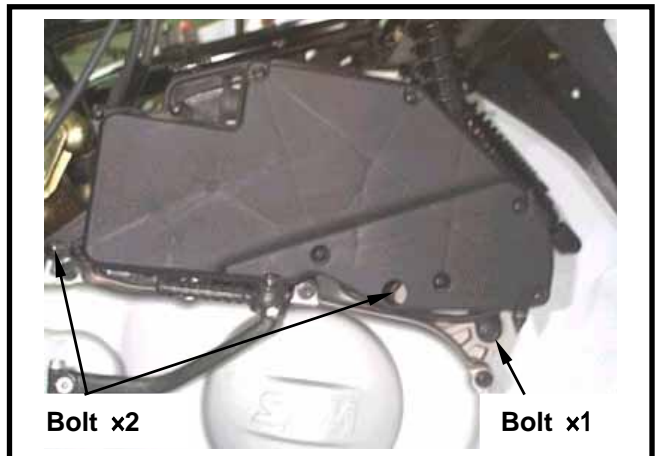

Remove the lower mounting bolt of left shock absorber.



Removal of Engine Mounting Bracket

Remove coil wire from engine mounting bracket.
Remove the bolts and nuts of engine mounting bracket.
Remove engine mounting bracket bolts.

Caution

- Support engine with special engine supporter to prevent from engine falling down.

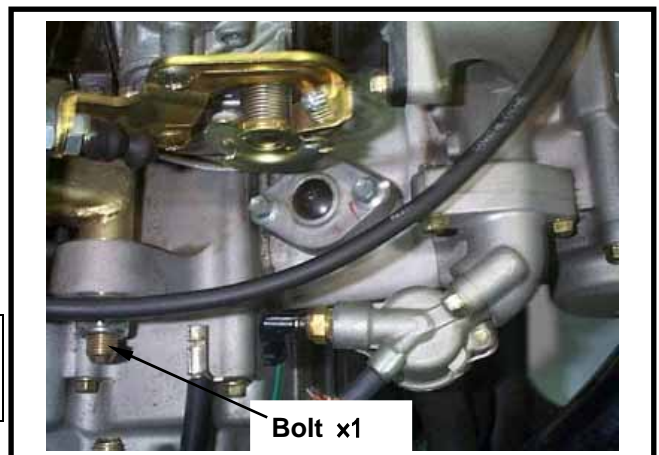

5. ENGINE REMOVAL



Check if engine mounting bracket bushing and cushion rubber for damage.

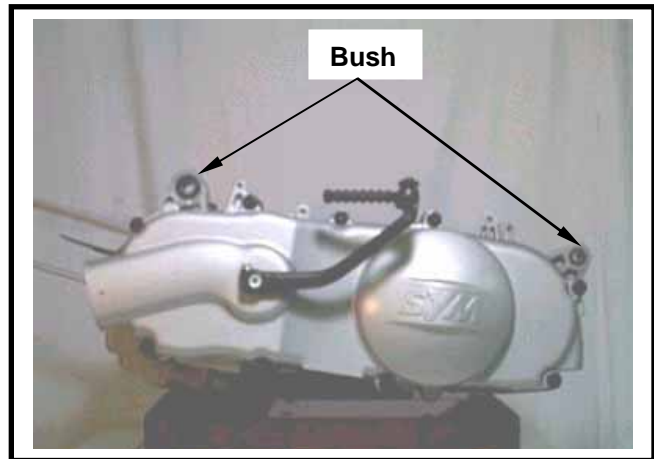

Engine Mounting Bracket Installation

Install engine onto engine mounting bracket.
Install engine mounting bracket bolts & nuts and then tighten the nuts.

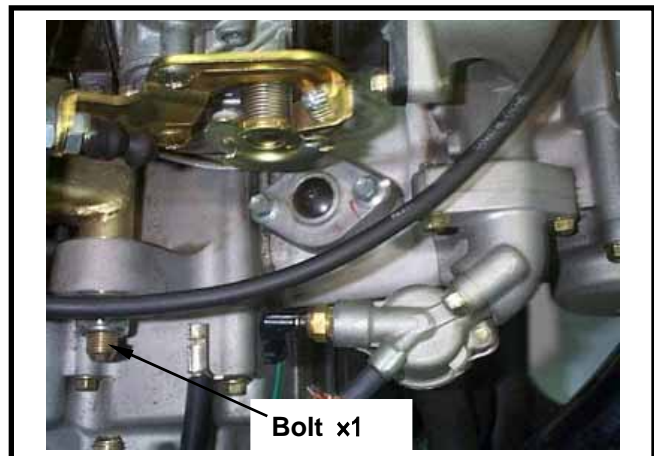

Engine Installation

Check if the bushings of engine suspension parts and shock absorber for damage.
Install engine in the reverse procedures of removal.

Caution

- Pay attention of foot & hand safety as engine installation to avoid hurting.
- Do not bend or twist wires.
- Cables wires have to be routed in accordance with normal layout.
- Small-end bearing ring has to forward to inside (bearing) as assembling the swing arm.



Engine Mounting Bolt:

Torque value: 4.0~5.0 kgf-m

Rear shock absorber bolt:

Torque value: UPPER: 3.5~4.5 kgf-m
LOWER: 2.4~3.0 kgf-m

Rear wheel shaft bolt:

Torque value: 11.0~13.0 kgf-m

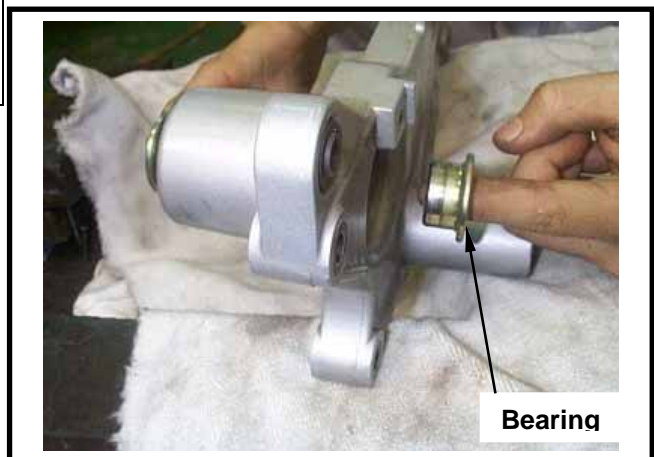

Mechanism Diagram	6-1	Valve stem replacement.....	6-8
Precautions in Operation	6-2	Valve seat inspection and service..	6-9
Cylinder Head Removal	6-4	Cylinder head reassembly	6-11
Cylinder Head Disassembly	6-6	Cylinder head Installation	6-12

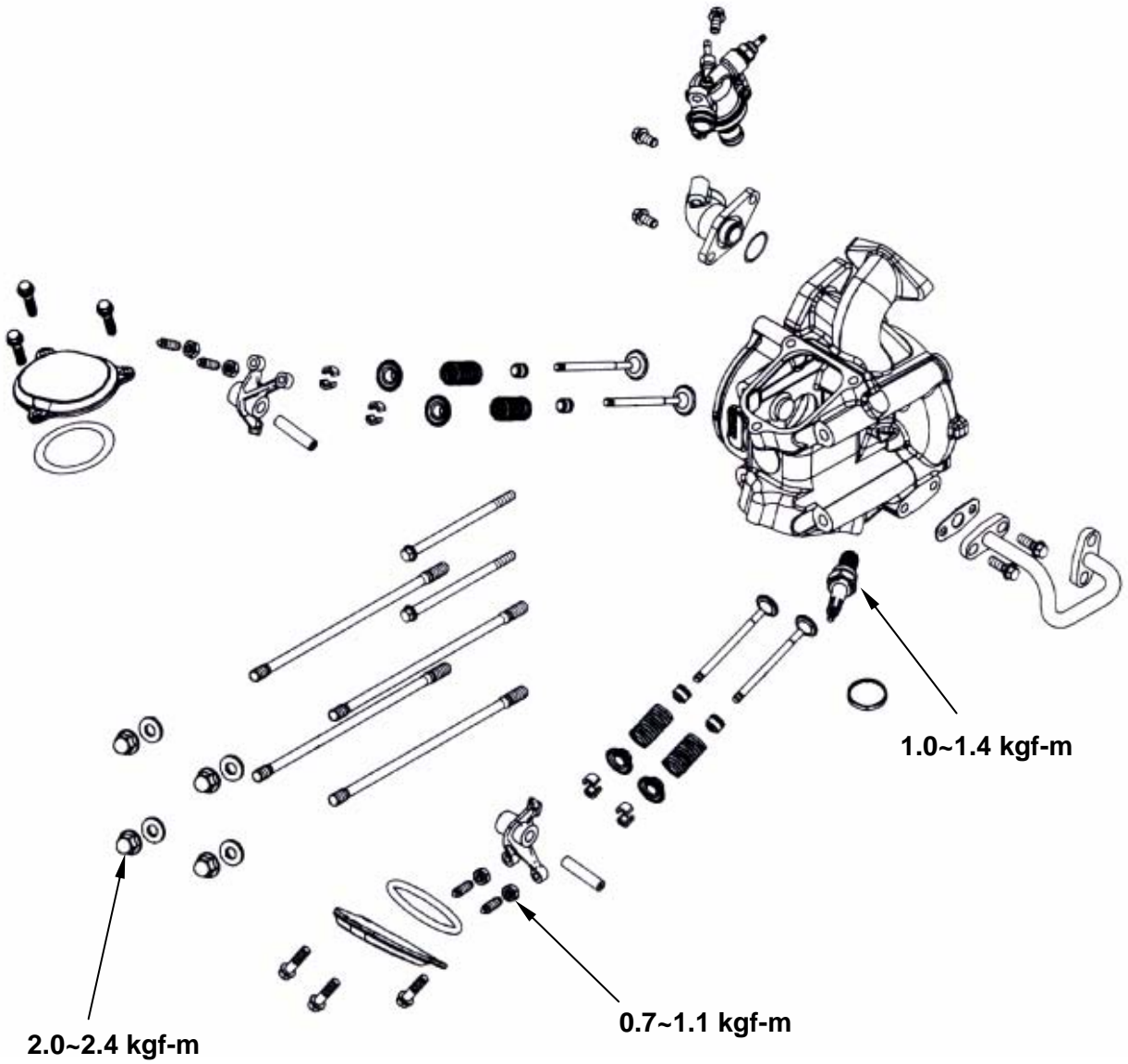

PRECAUTIONS IN OPERATION

General Information

- This chapter is contained maintenance and service for cylinder head, valve, and camshaft as well as rocker arm.
- Cylinder head service can be carried out when engine is in frame.

Specification

Item		Standard	Limit	
Compression pressure		12+/-2 kg/cm ²	---	
Camshaft	Height of cam lobe	Intake	30.800~30.920	
		Exhaust	30.411~30.531	
Rocker arm	ID of valve rocker arm	12.000~12.018	12.10	
	OD of valve rocker arm shaft	11.966~11.984	11.910	
Valve	OD of valve stem	Intake	4.975~4.990	
		Exhaust	4.955~4.970	
	Guide seat		5.000~5.012	5.030
	Clearance between valve stem and guide	Intake	0.010~0.037	0.080
		Exhaust	0.030~0.057	0.100
	Free length of valve spring		35.000	31.500
Valve seat width		1.000	1.6	
Tilt angle of cylinder head		---	0.05	

Torque Value

Cylinder head bolt (LH)	2.0~2.4 kg-m
Cylinder head Nut	2.0~2.4 kg-m
Sealing bolt of cam chain auto-tensioner	0.8~1.2 kg-m
Bolt of cam chain auto-tensioner	1.2~1.6 kg-m
Cam sprocket cover bolts	0.8~1.2 kg-m
Cam sprocket bolt	1.0~1.2 kg-m

TOOLS**Special service tools**

Valve reamer: 5.0mm

Valve guide driver: 5.0mm

Valve spring compressor

Troubleshooting

Engine performance will be effected by troubles on engine top parts. The trouble usually can be determined or by performing cylinder compression test and judging the abnormal noise generated.

Low compression pressure**Valve**

- Improper valve adjustment
- Burnt or bent valve
- Improper valve timing
- Valve spring damage

Cylinder head

- Cylinder head gasket leaking or damage
- Tilt or crack cylinder

High compression pressure

- Too much carbon deposit on combustion chamber or piston head

Noise

- Improper valve clearance adjustment
- Burnt valve or damaged valve spring
- Camshaft wear out or damage
- Chain wear out or looseness
- Auto-tensioner wear out or damage
- Camshaft sprocket
- Rocker arm or rocker arm shaft wear out

6. CYLINDER HEAD/VALVE



CYLINDER HEAD REMOVAL

Remove cushion and body center cover.

Remove the clamp strip bolt of carburetor, and disconnect vacuum tube from the carburetor insulator.

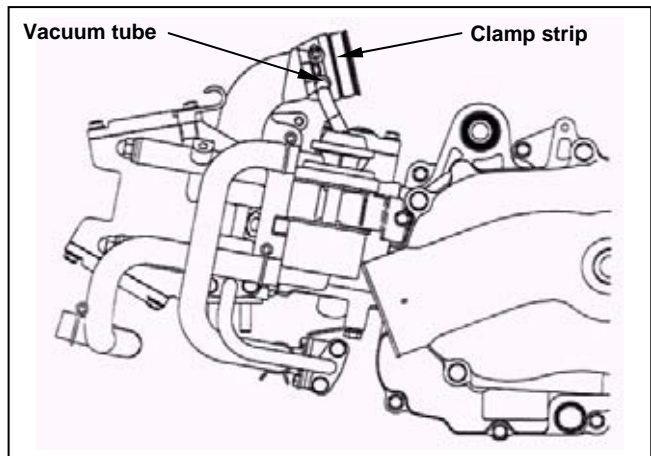

Remove 1 bolt of thermostat and then remove the thermostat.

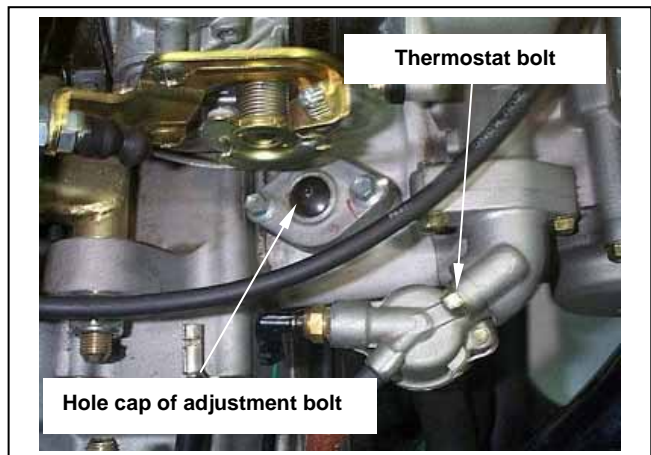

Remove the side cover mounting bolt of cylinder head, and then take out the side cover.

Remove hole cap for the adjustment bolt of cam chain tensioner, and then loosen the tensioner by turning a flat-driver in C.W direction.

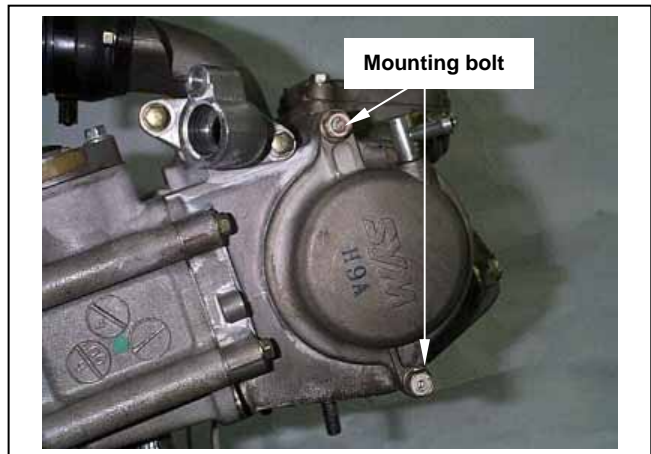

Remove cam sprocket bolt and then remove the sprocket by prying chain out.



Remove the 2 cylinder head mounting bolts from cylinder head side cover, and then remove 4 nuts and washers from cylinder head upper side.

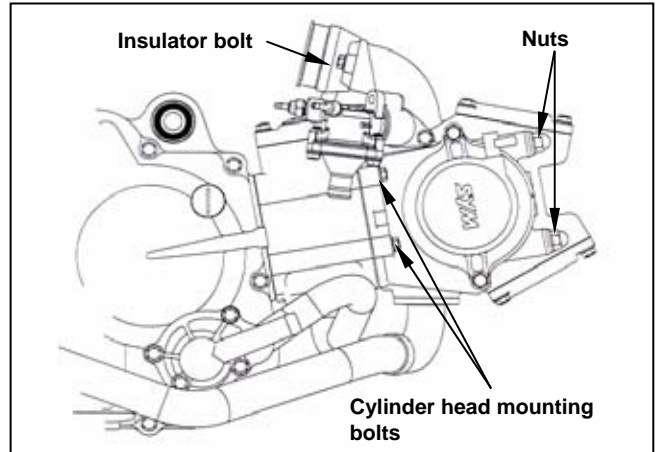

Remove the cylinder head.

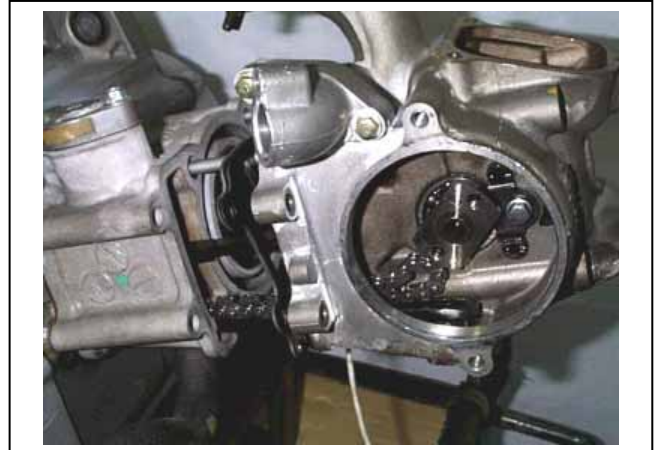

Remove 2 bolts of carburetor insulator and then take the insulator out.

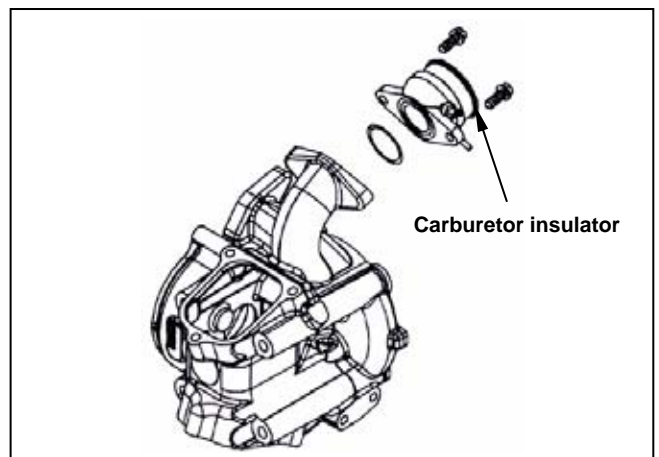

Remove cylinder head gasket and 2 dowel pins. Remove chain guide. Clean up residues from the matching surfaces of cylinder and cylinder head.

⚠ Caution

- Do not damage the matching surfaces of cylinder and cylinder head.
- Avoid residues of gasket or foreign materials falling into crankcase as cleaning.

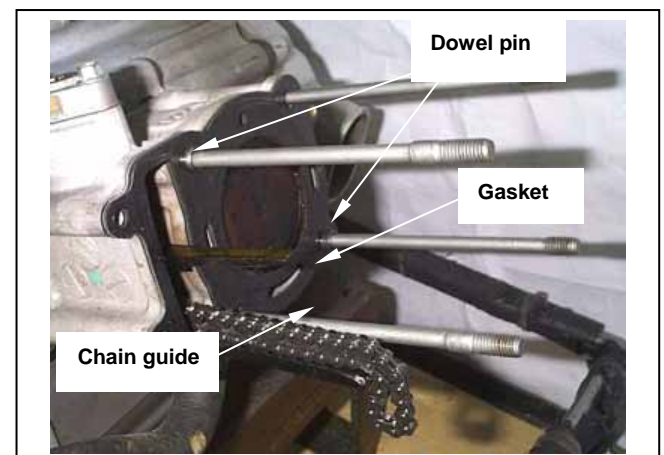

CYLINDER HEAD DISASSEMBLY

Remove the hole cap of intake & exhaust valve clearance adjustment. There are 6 bolts. Then, remove the cap.



Remove the rocker arm pin stopper plate, and then screw a 5mm bolt into the rocker arm pin. Finally, remove the pin and the rocker arm.

Screw a 6 mm bolt into cam sprocket mounting bolt hole, and then pull the camshaft out.

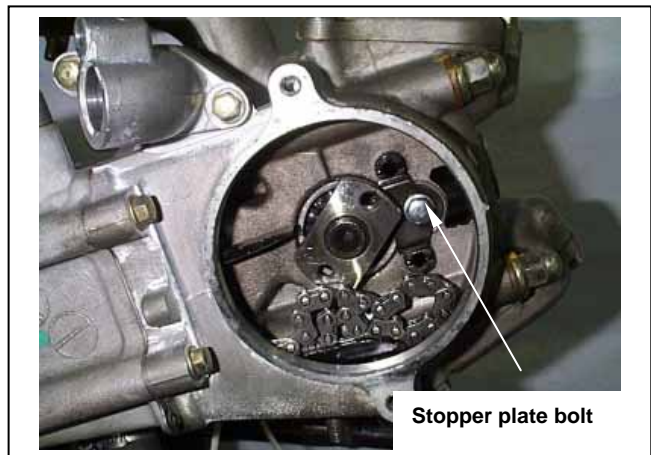

Use a valve compressor to press the valve spring.

After removed valve cotter, release the compressor and then take out spring retainer, valve spring and valves.

⚠ Caution

- In order to avoid losing spring elasticity, do not press the spring too much. Thus, press length is based on the valve cotter in which can be removed.

Tool: Valve spring compressor



Remove valve stem guide seal.

Clean carbon deposits in combustion chamber.
Clean residues and foreign materials on cylinder head matching surface.

⚠ Caution

- Do not damage the matching surface of cylinder head.

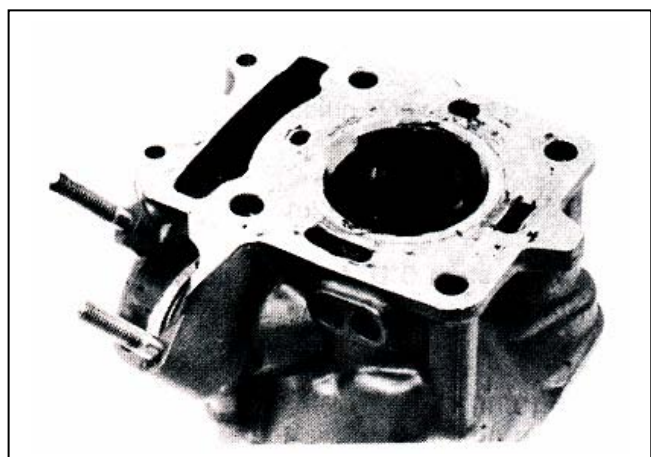

INSPECTION

CYLINDER HEAD

Check if spark plug and valve holes are cracked. Measure cylinder head warp with a straightedge and thickness gauge.

Service limit: 0.5 mm

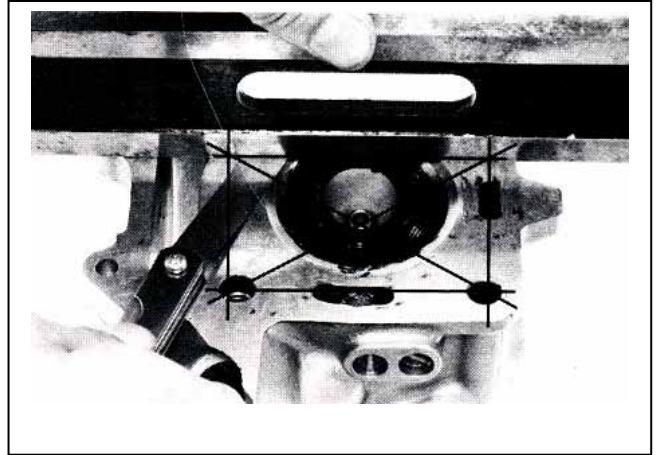

Valve spring free length

Measure the free length of intake and exhaust valve springs.

Service limit: 31.5 mm

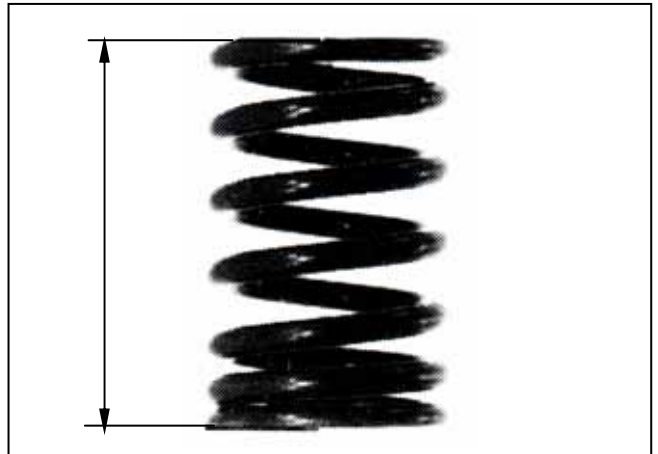

Valve stem

Check if valve stems are bend, crack or burn. Check the operation condition of valve stem in valve guide, and measure & record the valve stem outer diameter.

Service Limit: IN: 4.90 mm

EX: 4.90 mm

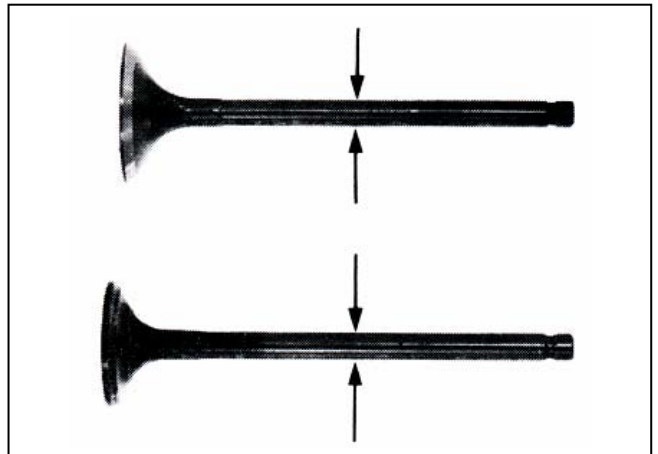

Valve guide

⚠ Caution

- Before measuring the valve guide, clean carbon deposits with reamer.

Tool: 5.0 mm valve guide reamer

Measure and record each valve guide inner diameters.

Service limit: 5.03 mm

The difference that the inner diameter of valve guide deducts the outer diameter of valve stem is the clearance between the valve stem and valve guide.

Service Limit: IN→0.08 mm

EX→0.10 mm

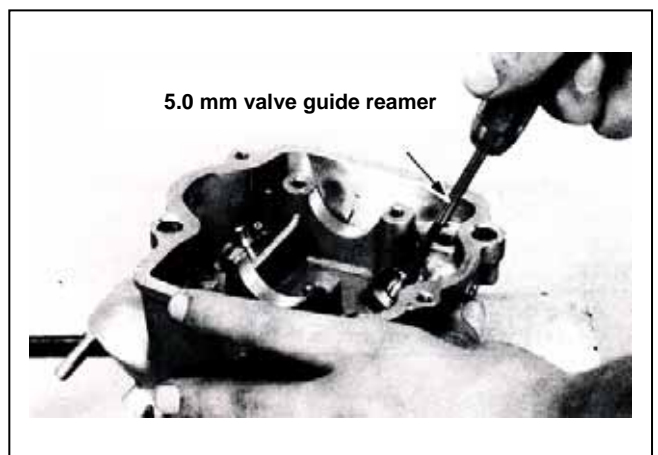

⚠ Caution

- If clearance between valve stem and valve guide exceeded service limit, check whether the new clearance that only replaces new valve guide is within service limit or not. If so, replace valve guide.

Correct it with reamer after replacement.
If clearance still exceeds service limit after replaced valve guide, replace valve stem too.

⚠ Caution

It has to correct valve seat when replacing valve guide.

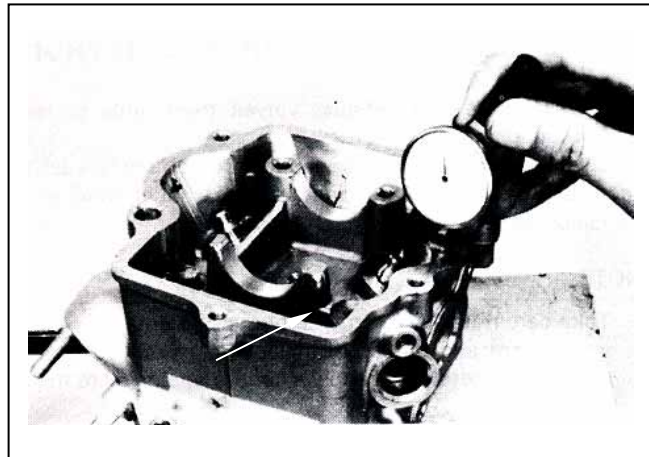

VALVE STEM REPLACEMENT

Heat up cylinder head to 100~150 °C with heated plate or toaster.

⚠ Caution

- Do not let torch heat cylinder head directly. Otherwise, the cylinder head may be deformed as heating it.
- Wear on a pair of glove to protect your hands when operating.

Hold the cylinder head, and then press out old valve guide from combustion chamber side.

Tool: Valve guide driver: 5.0 mm

⚠ Caution

- Check if new valve guide is deformation after pressed it in.
- When pressing in the new valve guide, cylinder head still have to be kept in 100~150°C.

Adjust the valve guide driver and let valve guide height is in 13 mm.

Press in new valve guide from rocker arm side.

Tool: Valve guide driver: 5.0 mm

Wait for the cylinder head cooling down to room temperature, and then correct the new valve guide with reamer.

⚠ Caution

- Using cutting oil when correcting valve guide with a reamer.
- Turn the reamer in same direction when it be inserted or rotated.

Correct valve seat, and clean up all metal residues from cylinder head.

Tool: Valve guide reamer: 5.0 mm

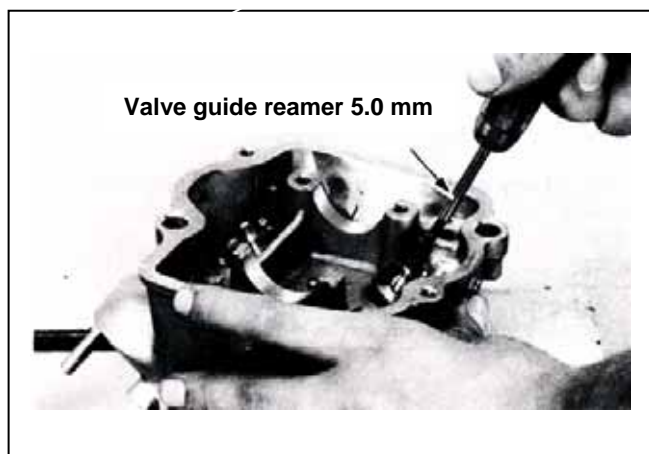
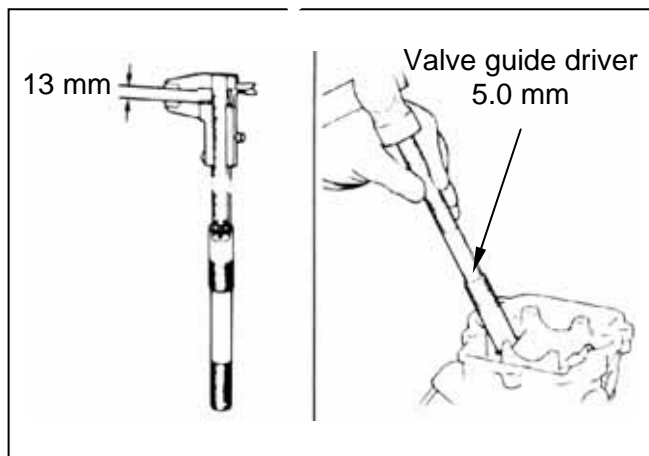
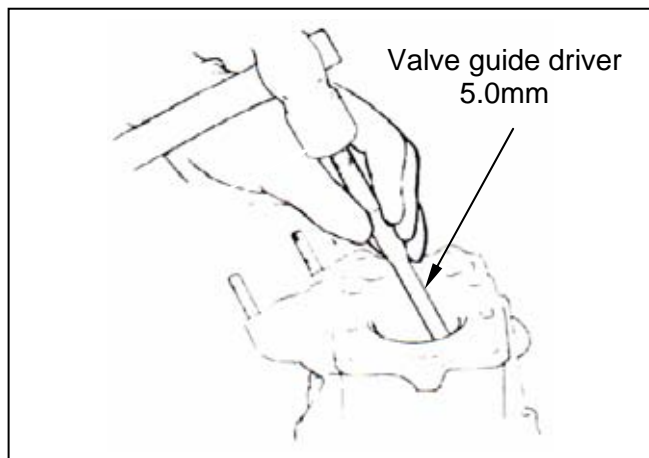

VALVE SEAT INSPECTION AND SERVICE

Clean up all carbon deposits onto intake and exhaust valves.

Apply with emery slightly onto valve contact face. Grind valve seat with a rubber hose or other manual grinding tool.

⚠ Caution

- Do not let emery enter into between valve stem and valve guide.
- Clean up the emery after corrected, and apply with engine oil onto contact faces of valve and valve seat.

Remove the valve and check its contact face.

⚠ Caution

- Replace the valve with new one if valve seal is roughness, wear out, or incomplete contacted with valve seat.

Valve seat inspection

If the valve seat is too width, narrow or rough, correct it.

Valve seat width

Service limit: 1.6mm

Check the contact condition of valve seat.

Valve seat grinding

The worn valve seat has to be ground with valve seat chamfer cutter.

Refer to operation manual of the valve seat chamfer cutter.

Use 45° valve seat chamfer cutter to cut any rough or uneven surface from valve seat.

⚠ Caution

- After valve guide had been replaced, it has to be ground with 45° valve seal chamfer cutter to correct its seat face.

Use 32° cutter to cut a quarter upper part out.

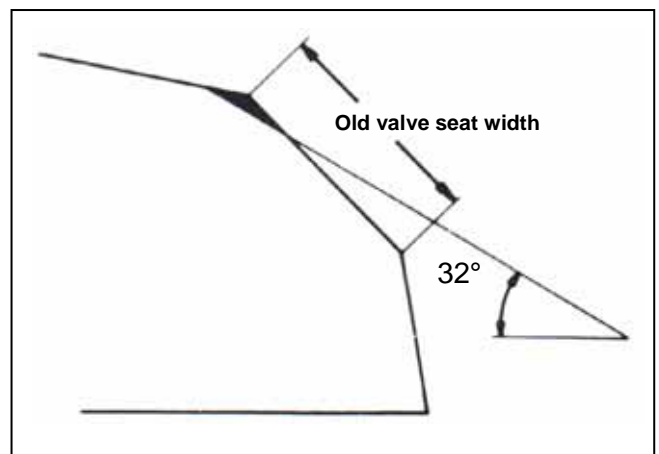
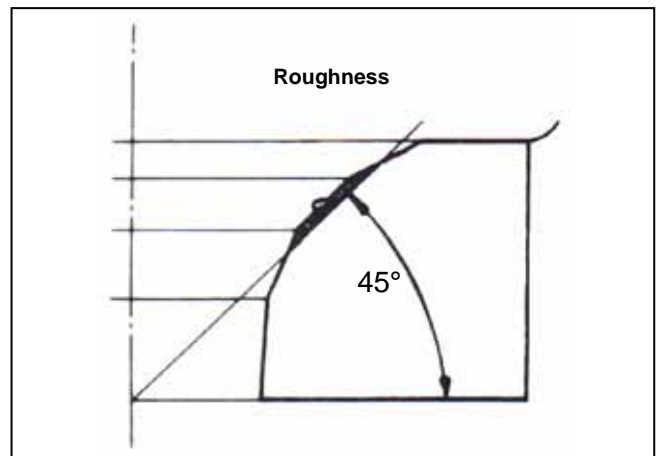
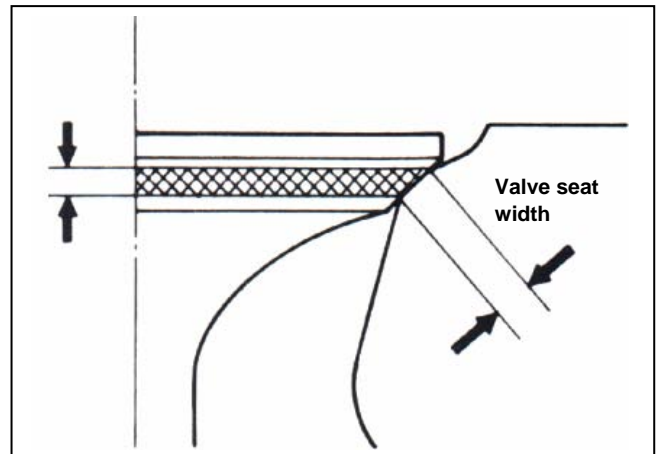
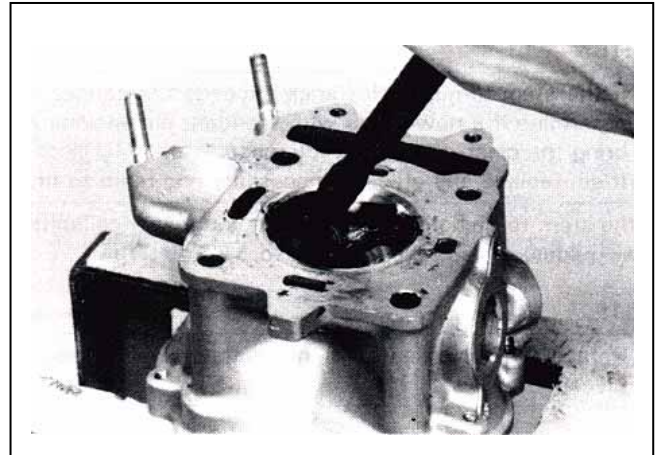

6. CYLINDER HEAD/VALVE

Use 60° cutter to cut a quarter lower part out.
Remove the cutter and check new valve seat.

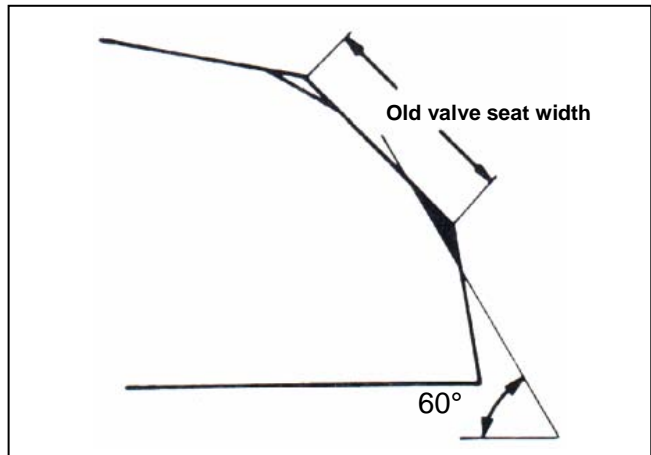

Use 45° cutter to grind the valve seat to specified width.

⚠ Caution

- Make sure that all roughness and uneven faces had been ground.

Grind valve seat again if necessary.

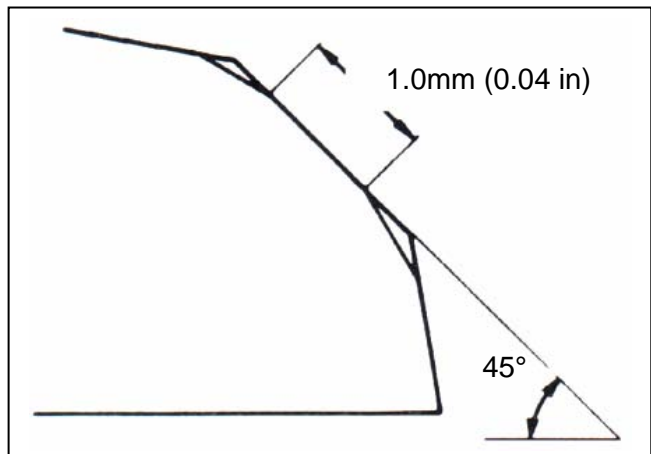

Coat the valve seat surface with red paint.
Install the valve through valve guide until the valve contacting with valve seat, slightly press down the valve but do not rotate it so that a seal track will be created on contact surface.

⚠ Caution

- The contact surfaces of valve and valve seat are very important to the valve sealing capacity.

If the contact surface too high, grind the valve seat with 32° cutter.
Then, grind the valve seat to specified width.

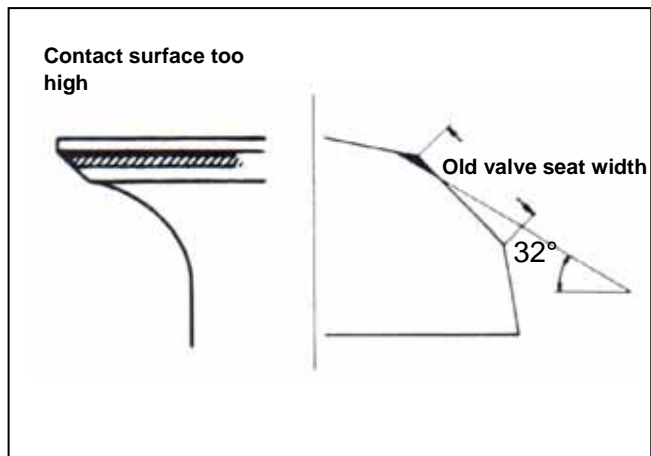

If the contact surface too low, grind the valve seat with 60° cutter.
Then, grind the valve seat to specified width.

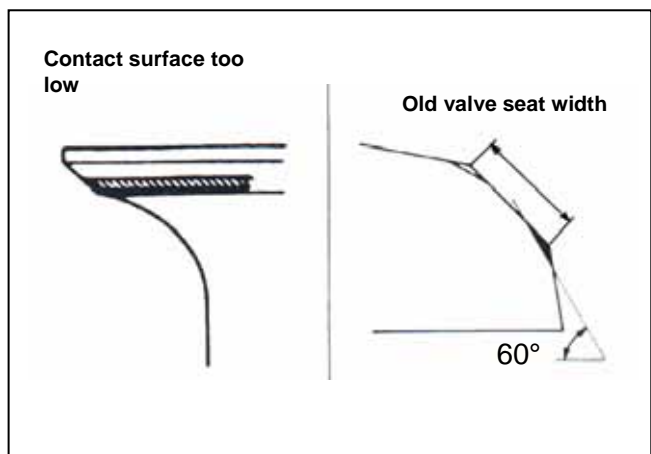

After the valve seat ground, coat valve seat surface with emery and then slightly press the ground surface.
Clean up all emery coated onto cylinder and valve after ground.

CYLINDER HEAD REASSEMBLY

Lubricate valve stem with engine oil, and then insert the valve into valve guide.
Install new valve stem oil seal.
Install valve springs and retainers.

⚠ Caution

- The closed coils of valve spring should face down to combustion chamber.

Use valve spring compressor to press valve spring.
Install valve cotter and release the valve compressor.

⚠ Caution

- In order to avoid losing spring elasticity, do not press the spring too much. Thus, press length is based on the valve cotter in which can be removed.

Tool: valve spring compressor.

Tap valve stem to make valve retainer and valve stem sealing properly.

⚠ Caution

- Place and hold cylinder head on to working table so that can prevent from valve damaged.

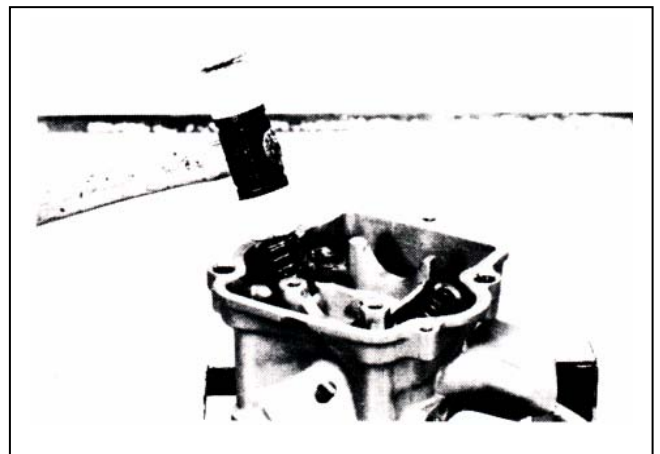
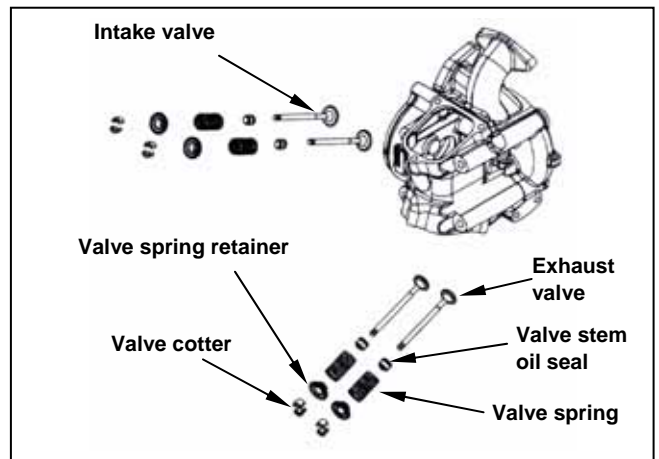
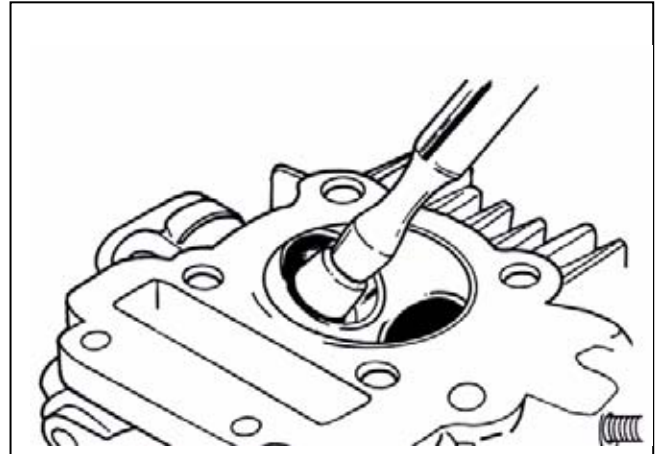

6. CYLINDER HEAD/VALVE



CYLINDER HEAD INSTALLATION

Install a new O-ring into the indent of carburetor insulator, and then install the insulator onto cylinder head with 2 bolts.

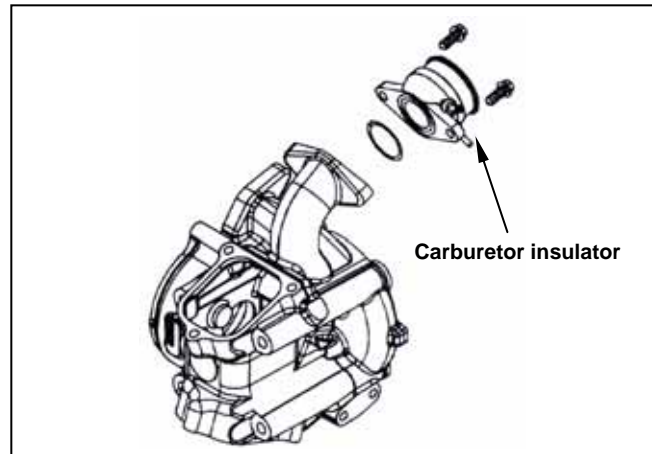

Install camshaft into cylinder head, and align rocker pin with rocker arm pin hole. Then, insert the rocker arm pin. Install rocker arm pin mounting plate.

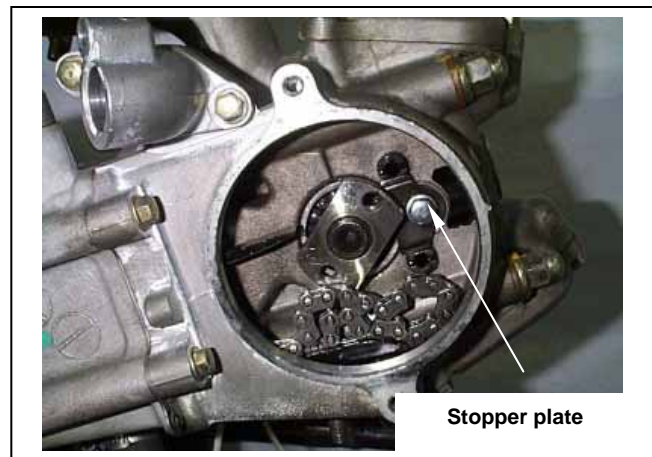

Loosen valve clearance adjustment nuts and bolts located on valve rocker arm. Measure and adjust valve clearance with thickness gauge.

After valve clearance had been adjusted to standard value, hold adjustment bolt and then tighten the adjustment nut.

**Valve clearance: Intake: 0.12 +/- 0.02 mm
Exhaust: 0.12 +/- 0.02 mm**

Install valve clearance adjustment hole cap with 3 bolts and tighten the bolts.



Clean up all residues and foreign materials onto the matching surfaces of both cylinder and cylinder head.

Install chain guide.

Install 2 set pins and cylinder head gasket.

⚠ Caution

- Do not damage the matching surfaces of cylinder and cylinder head.
- Avoid residues of gasket or foreign materials falling into crankcase as cleaning.

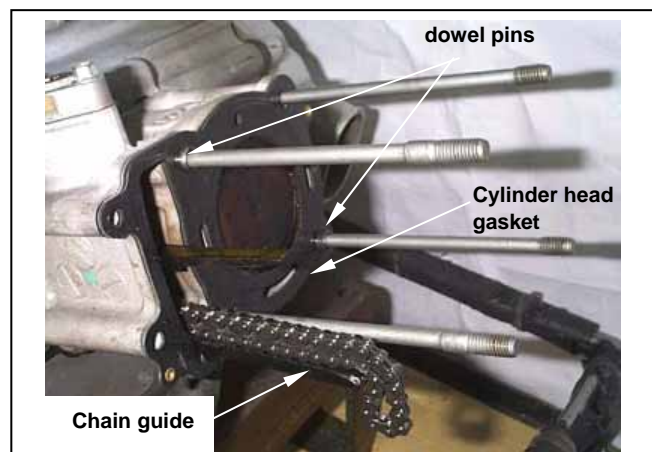

Install cylinder head.

Tighten 4 nuts and washers on the cylinder head upper side, and then tighten 2 cylinder head mounting bolts of cylinder head side cover.

Torque value: 2.0~2.4 kgf-m

Install and tighten spark plug

Torque value: 2.0~2.4 kgf-m

⚠ Caution

- This model is equipped with more precision 4-valve mechanism so its tighten torque can not be exceeded standard value in order to avoid causing cylinder head deformation, engine noise and leaking so that motorcycle's performance be effected.

Install cam chain on to sprocket and align the timing mark on the sprocket with that of cylinder head.

Align sprocket bolt hole with camshaft bolt hole. Tighten the sprocket mounting bolt.

⚠ Caution

- Make sure timing marks are matched.

Install a new O-ring onto thermostat and tighten its mounting bolts.

Loosen sprocket chain tensioner and let it contact with chain plate tightly. Tighten the bolt cap of tensioner adjustment hole.

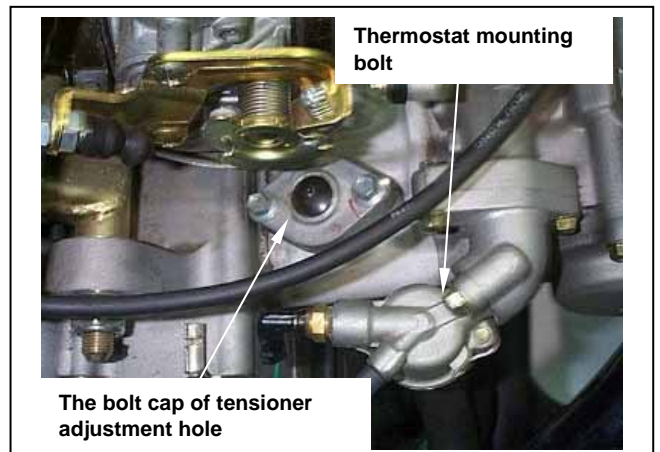
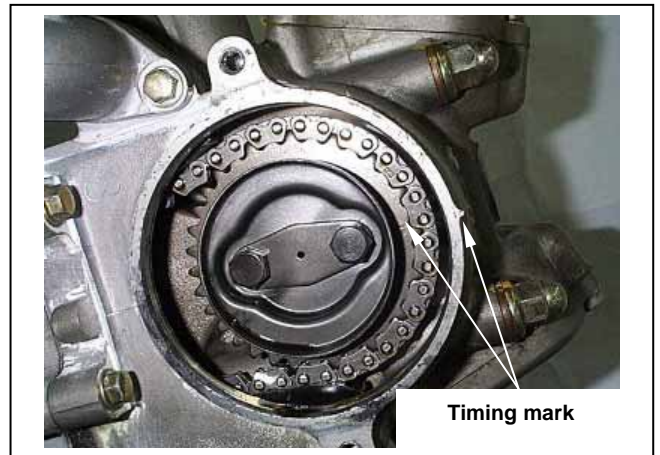
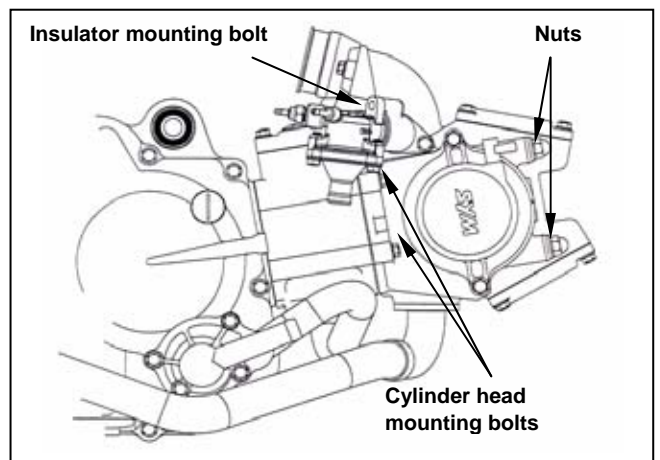
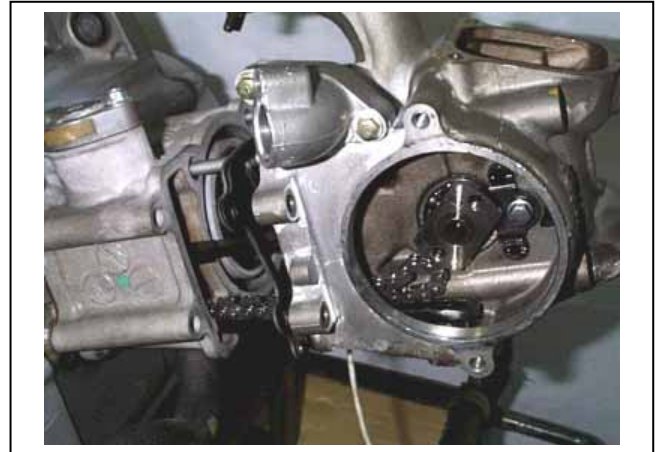

Install carburetor insulator onto carburetor and tighten clamp strip bolt. Install the vacuum hose of carburetor insulator.

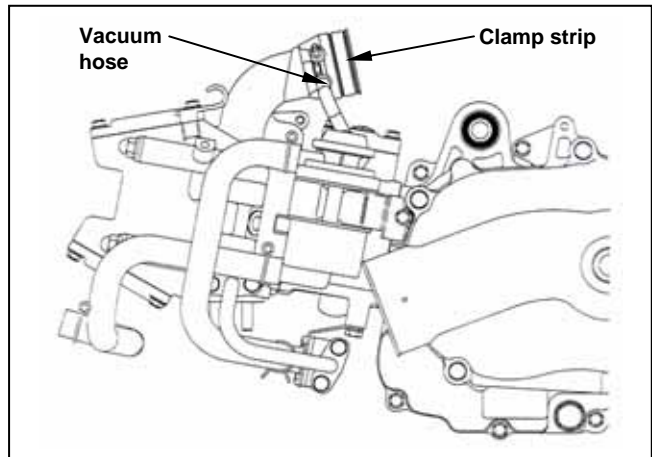

Remove the intake valve adjustment hole cap
Start engine, and make sure that lubricant flows to cylinder head.

Turn off engine after confirmed, and install the intake valve adjustment hole cap.

Install seat cushion and body center cover.

⚠ Caution

- If lubricant does not flow to cylinder head, engine components will be worn out seriously. Thus, it must be confirmed.
- When checking lubricant flowing condition, run the engine in idle speed. Do not accelerate engine speed.



Mechanism Diagram	7-1	Piston Removal.....	7-4
Precautions in Operation	7-2	Piston Ring Installation.....	7-6
Trouble Diagnosis.....	7-2	Piston Installation.....	7-7
Cylinder Removal.....	7-3	Cylinder Installation	7-7

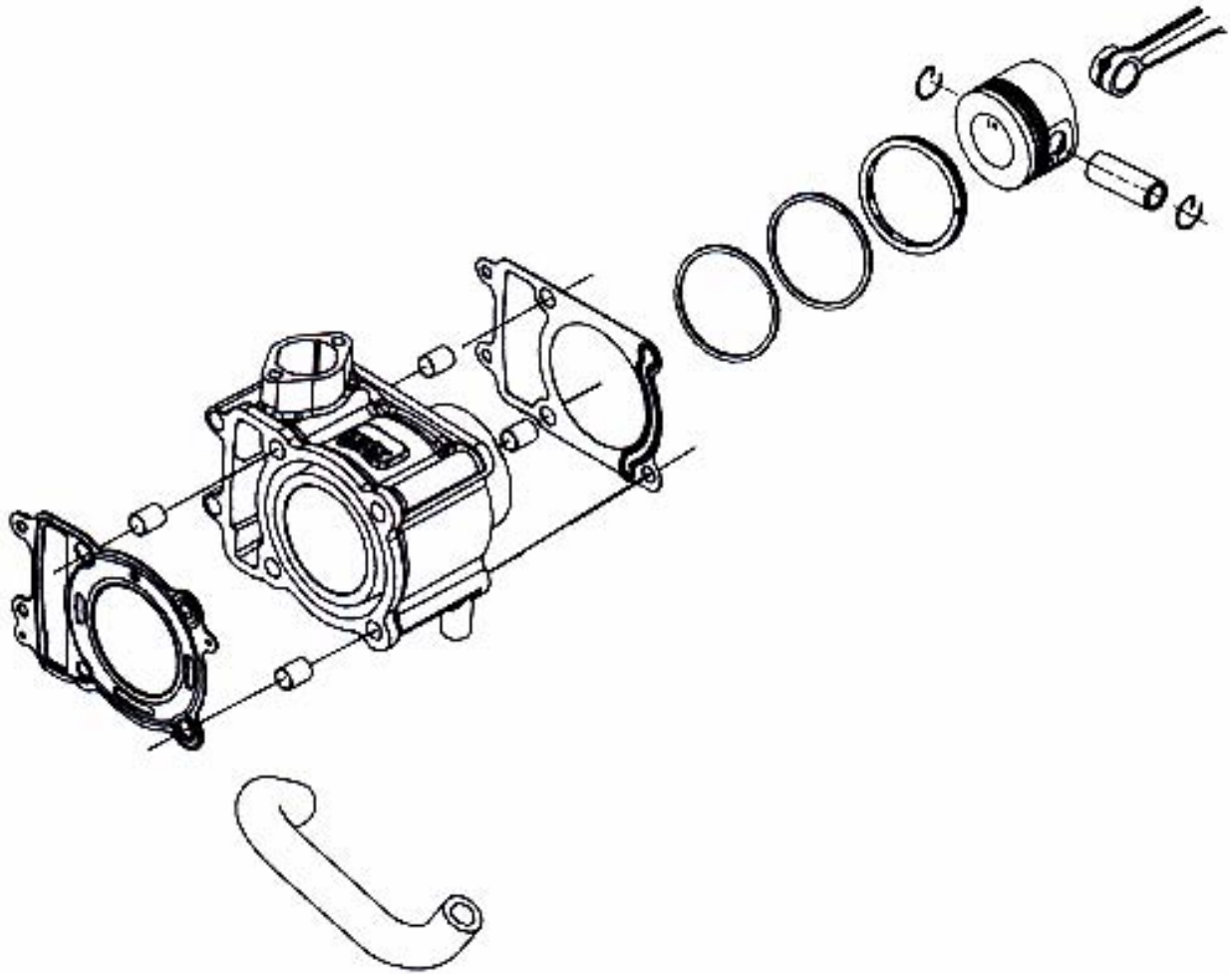

PRECAUTIONS IN OPERATION

General Information

- Both cylinder and piston service can be carried out when engine mounted on frame.

Specification

LA12W & LA15W & LA18W

Item		Standard	Limit	
Cylinder	ID (LA18W not included)	56.995~57.015	57.016	
	Bend	-	0.050	
Piston/ Piston ring	Clearance between piston rings	Top ring	0.015~0.050	
		2 nd ring	0.015~0.050	
	Ring-end gap	Top ring	0.150~0.300	
		2 nd ring	0.300~0.450	
		Oil ring side rail	0.200~0.700	
	OD of piston (LA18W not included)		56.985~57.005	56.900
	Clearance between piston and cylinder		0.010~0.040	0.100
ID of piston pin boss		15.002~15.008	15.040	
OD of piston pin		14.960~15.000	14.930	
Clearance between piston and piston pin		0.002~0.014	0.020	
ID of connecting rod small-end		15.016~15.034	15.060	

LA18W

Item		Standard	Limit
Cylinder	ID	60.995~61.015	61.016
Piston	OD of piston	60.985~61.005	60.900

TROUBLE DIAGNOSIS

Low Or Unstable Compression Pressure

Cylinder or piston ring worn out

Smoking in Exhaust Pipe

Piston or piston ring worn out
Piston ring installation improperly
Cylinder or piston damage

Knock or Noise

Cylinder or piston ring worn out
Carbon deposits on cylinder head top side
Thermostat burnt

Engine Overheat

Carbon deposits on cylinder head top side
Cooling pipe clogged or not enough in coolant flow

CYLINDER REMOVAL

Remove cylinder head (refer to chapter 6).
 Remove coolant hose from cylinder head.
 Remove cylinder.

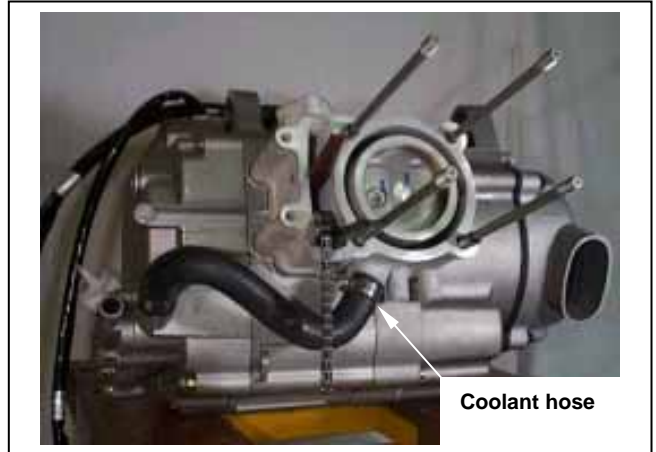

Remove cylinder gasket and dowel pin.



Cover the holes of crankcase and cam chain with a piece of cloth.
 Clean up all residues or foreign materials from the two matching surfaces of cylinder and crankcase.

⚠ Caution

Soap the residues into solvent so that the residues can be removed more easily.

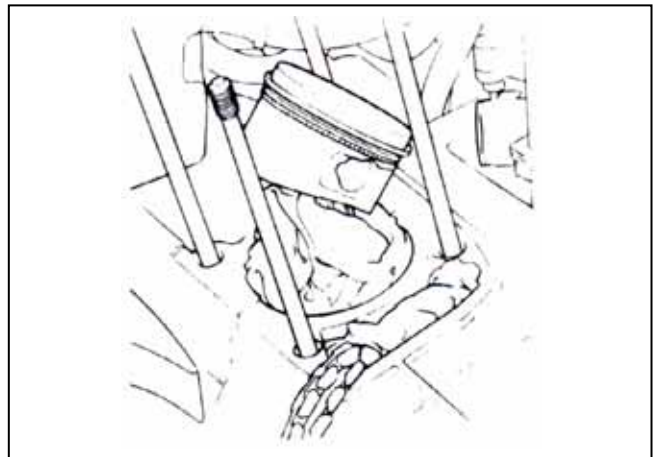

Inspection

Check if the inner diameter of cylinder is wear out or damaged.
 In the 3 positions, top, center and bottom, of cylinder, measure the X and Y values respective in the cylinder.

Service limit:

LA12W & LA15W:57.016 mm

LA18W:61.016 mm

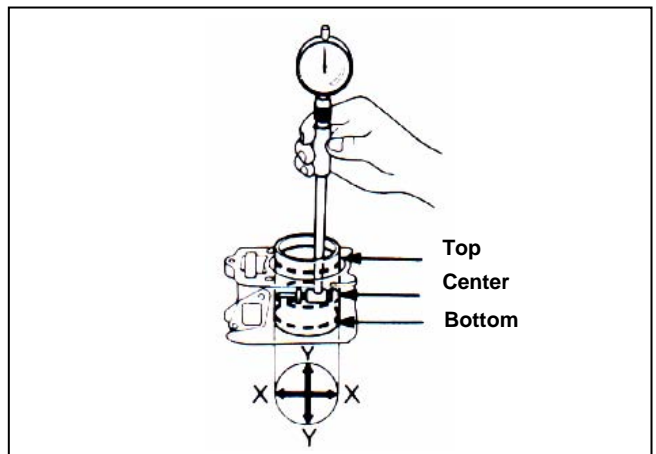

Check cylinder if warp.
Service limit: 0.05 mm

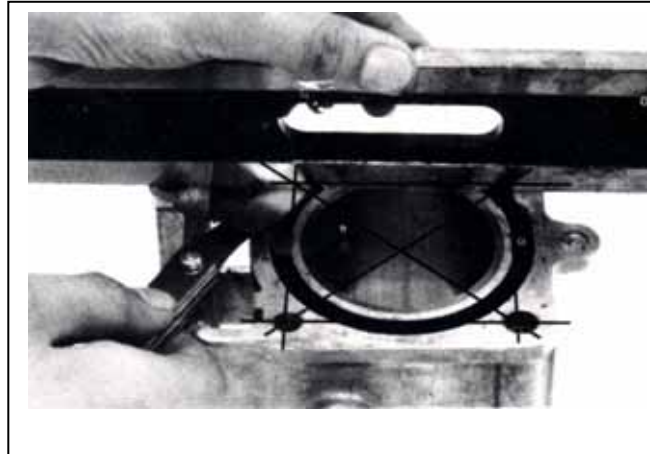

PISTON REMOVAL

Plug crankcase opening with a cleaning cloth to prevent from piston pin snap ring or other foreign materials falling into crankcase when disassembling.

Hold another snap ring with pliers.

Push out the piston pin from the side that not removed the snap ring.



Inspection

Measure clearance between piston ring and its grooves.

Service Limit: **Top ring: 0.09 mm**
 2nd ring: 0.09 mm



Remove piston rings

Check if the piston rings are damaged or its grooves are worn.

⚠ Caution

- Pay attention to remove piston rings because they are fragile.



Place piston rings respective into cylinder below 20 mm of cylinder top. In order to keep the piston rings in horizontal level in cylinder, push the rings with piston.

Service Limit: **Top ring: 0.50 mm**
 2nd ring: 0.65 mm

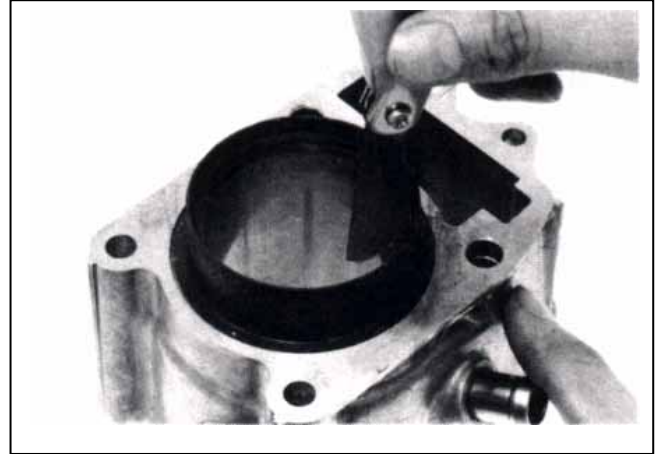

Measure the outer diameter of piston pin.

Service Limit: 14.93 mm



Measure the inner diameter of connecting rod small end.

Service Limit: 15.06 mm

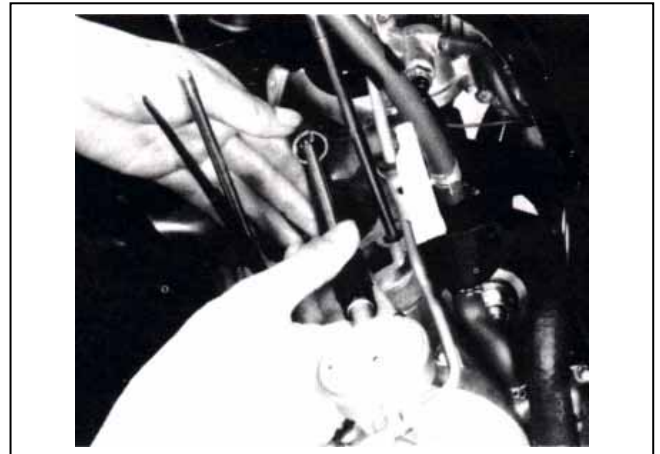

Measure the inner diameter of piston pin hole.

Service Limit: 15.04 mm

Calculate clearance between piston pin and its hole.

Service Limit: 0.02 mm

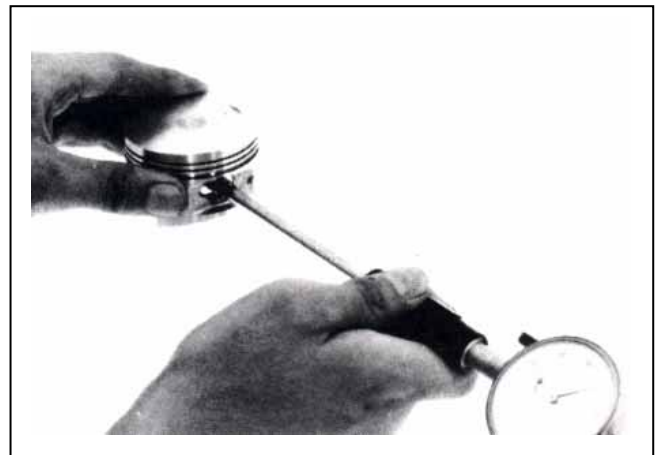

7. CYLINDER/PISTON



Measure piston outer diameter.

⚠ Caution

- The measurement position is 10 mm distance from piston bottom side, and 90° to piston pin.

Service limit:

LA12W & LA15W: 56.9 mm

LA18W: 60.9 mm

Compare measured value with service limit to calculate the clearance between piston and cylinder.



PISTON RING INSTALLATION

Clean up piston top, ring groove, and piston surface.

Install the piston ring onto piston carefully.

Place the openings of piston ring as diagram shown.

⚠ Caution

- Do not damage piston and piston rings as installation.
- All marks on the piston rings must be forwarded to up side.
- Make sure that all piston rings can be rotated freely after installed.

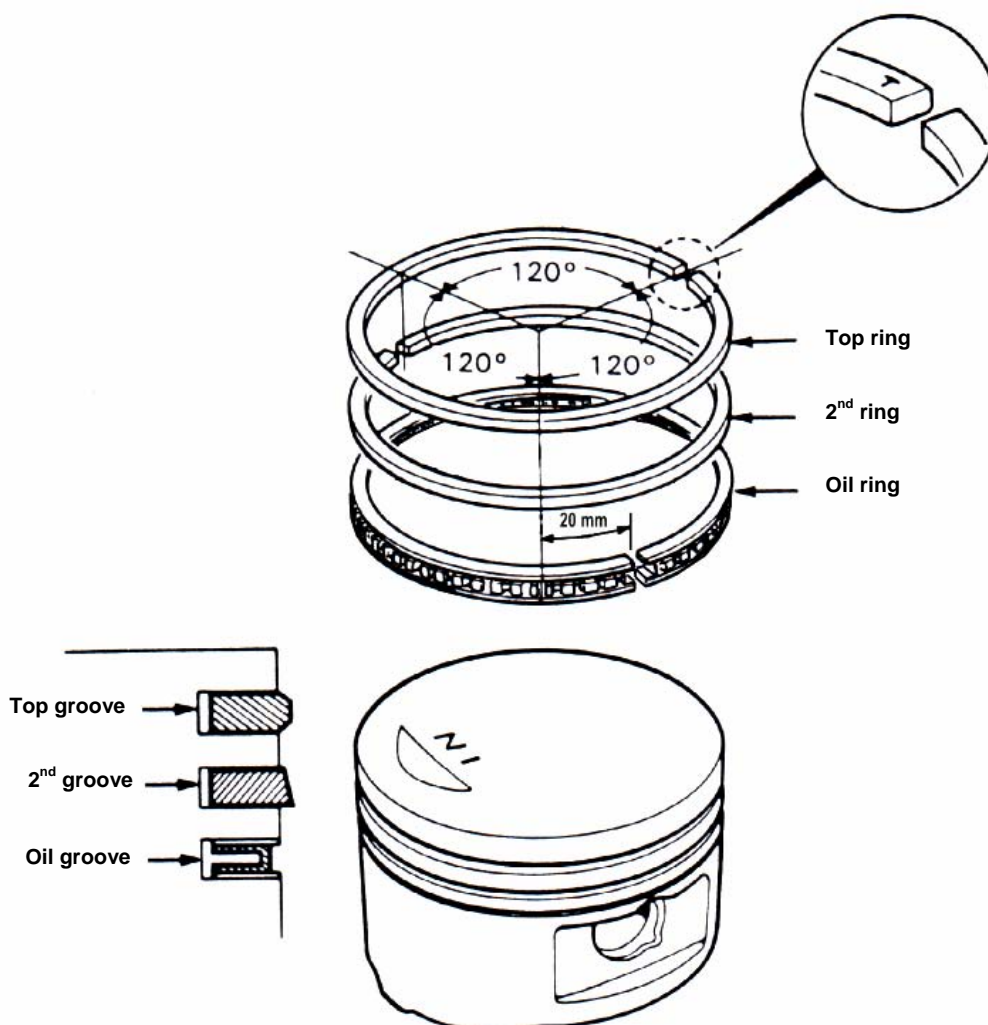

PISTON INSTALLATION

Install piston and piston pin, and place the IN marks on the piston top side forward to intake valve.

Install new piston pin snap ring.

⚠ Caution

- Do not let the opening of piston pin snap ring align with the opening piston ring.
- Place a piece of cloth between piston and crankcase in order to prevent snap ring from falling into crankcase as operation.



CYLINDER INSTALLATION

Clean up all residues and foreign materials on the matching surface of crankcase. Pay attention to not let these residues and foreign materials fall into crankcase.

⚠ Caution

Soap the residues into solvent so that the residues can be removed more easily.

Install dowel pins and new gasket.

Coat engine oil to inside of cylinder, piston and piston rings.

Care to be taken when installing piston into cylinder. Press piston rings in one by one as installation.

⚠ Caution

- Do not push piston into cylinder forcefully because piston and piston rings will be damaged.

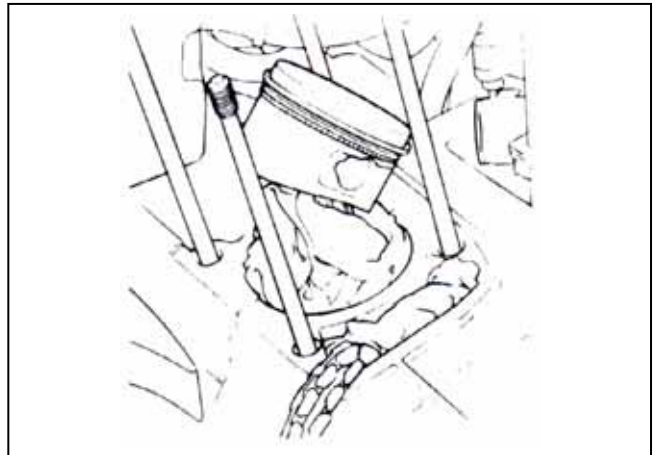

Install coolant hose onto cylinder.

Install cylinder head (refer to Chapter 6).



NOTES

Mechanism Diagram	8-1	Kick starter	8-3
Maintenance Description.....	8-2	Driving belt	8-5
Trouble Diagnosis.....	8-2	Drive face.....	8-6
Left crankcase cover	8-3	Clutch outer/Driven pulley	8-10

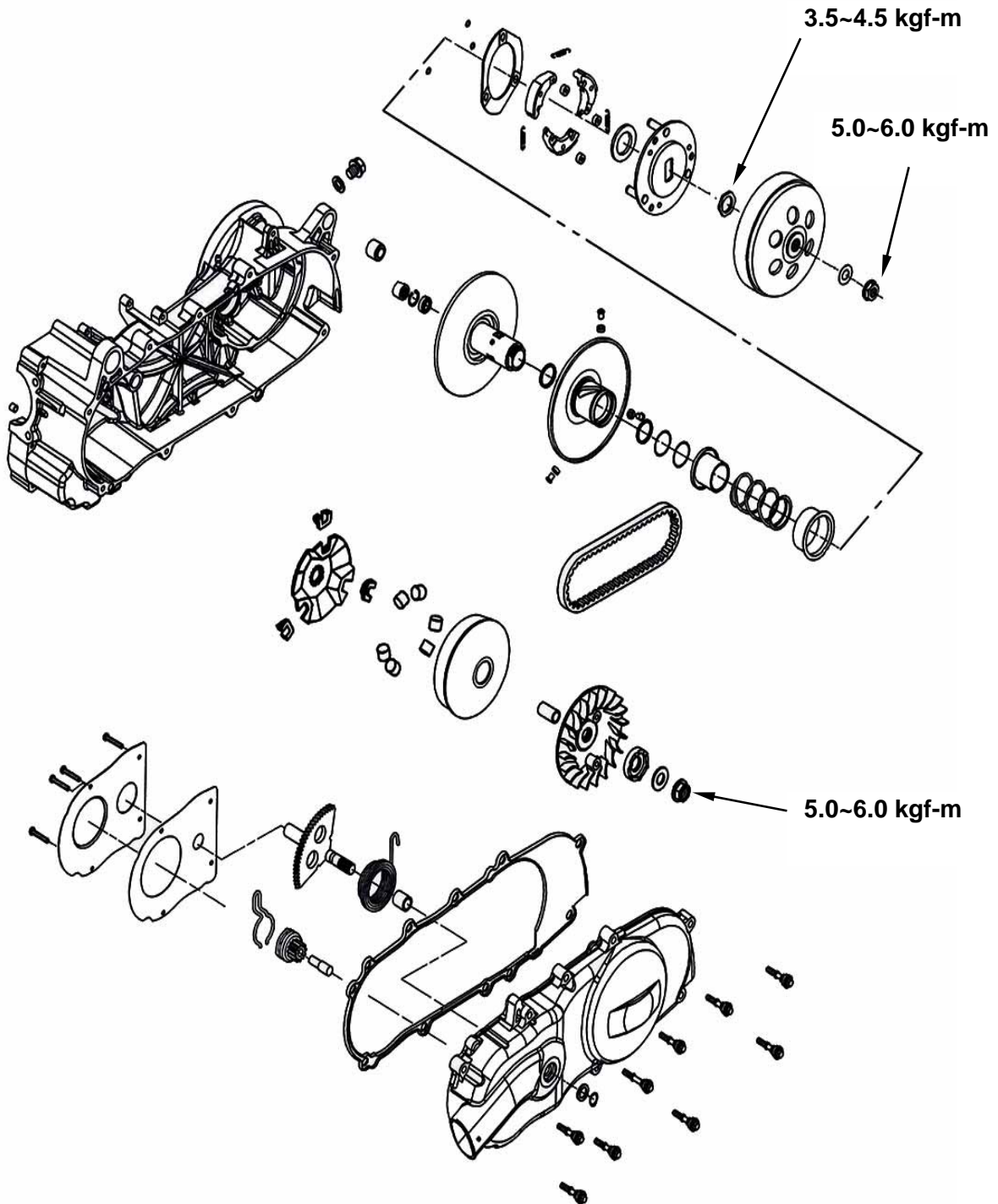

MAINTENANCE DESCRIPTION

Precautions in Operation

General Information

- Drive face, clutch outer, and driven pulley can be serviced on the motorcycle.
- Driving belt and driving pulley must be free of grease.

Item	Standard value (mm)	Limit (mm)
Driving belt width	19.000	17.500
ID of drive face boss	27.000~27.021	27.060
OD of drive face	26.970~26.990	26.940
OD of roller	19.950~20.100	19.500
ID of clutch outer	130.000~130.200	130.500
Thickness of clutch weight	4.000~4.100	2.000
Free length of driven pulley spring	88.300	83.200
OD of driven pulley	33.965~33.985	33.940
ID of drive face	34.000~34.025	34.060

Torque value

- Driven face nut: 5.0~6.0 kgf-m
- Clutch outer nut: 5.0~6.0 kgf-m

Special Service Tools

- Clutch spring compressor
- Inner bearing puller
- Bearing driver
- Clutch nut wrench 39 x 41 mm
- Universal holder

TROUBLE DIAGNOSIS

Engine can be started but motorcycle can not be moved

1. Worn driving Belt
2. Worn drive face
3. Worn or damaged clutch weight
4. Broken driven pulley

Insufficient horsepower or poor high speed performance

1. Worn driving belt
2. Insufficient spring force of driven pulley
3. Worn roller
4. Driven pulley operation un-smoothly

Shudder or misfire when driving

1. Broken clutch weight
2. Worn clutch weight

LEFT CRANKCASE COVER

Left crankcase cover removal

- Remove body cover.
- Remove air cleaner (2 bolts).
- Remove kick starter (1 bolt).
- Remove L crankcase cover (9 bolts).

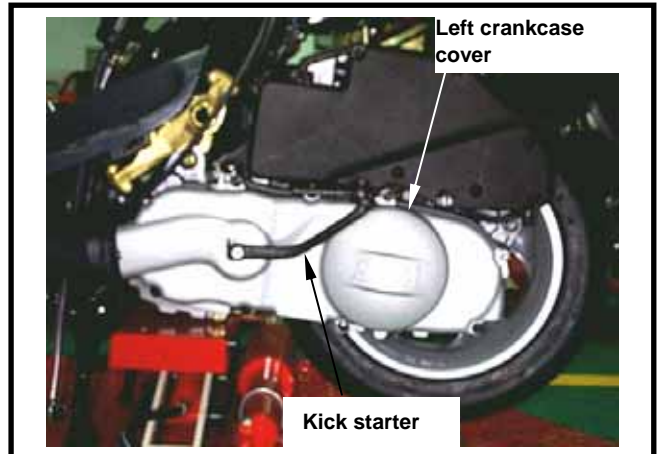

Disassembly of Kick Starter

- Remove snap ring and thrust washer from L crankcase cover.
- Install kick starter arm, rotate the arm slightly and then remove driven gear and washer. Remove the kick starter arm, starter spindle, and return spring as well as socket.

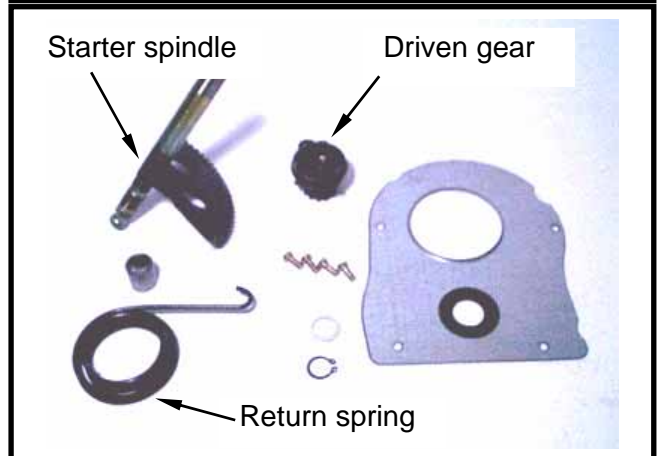

Inspection of Kick Starter

- Check if starter spindle, driven gear, socket and bearing hole for wear or damage.

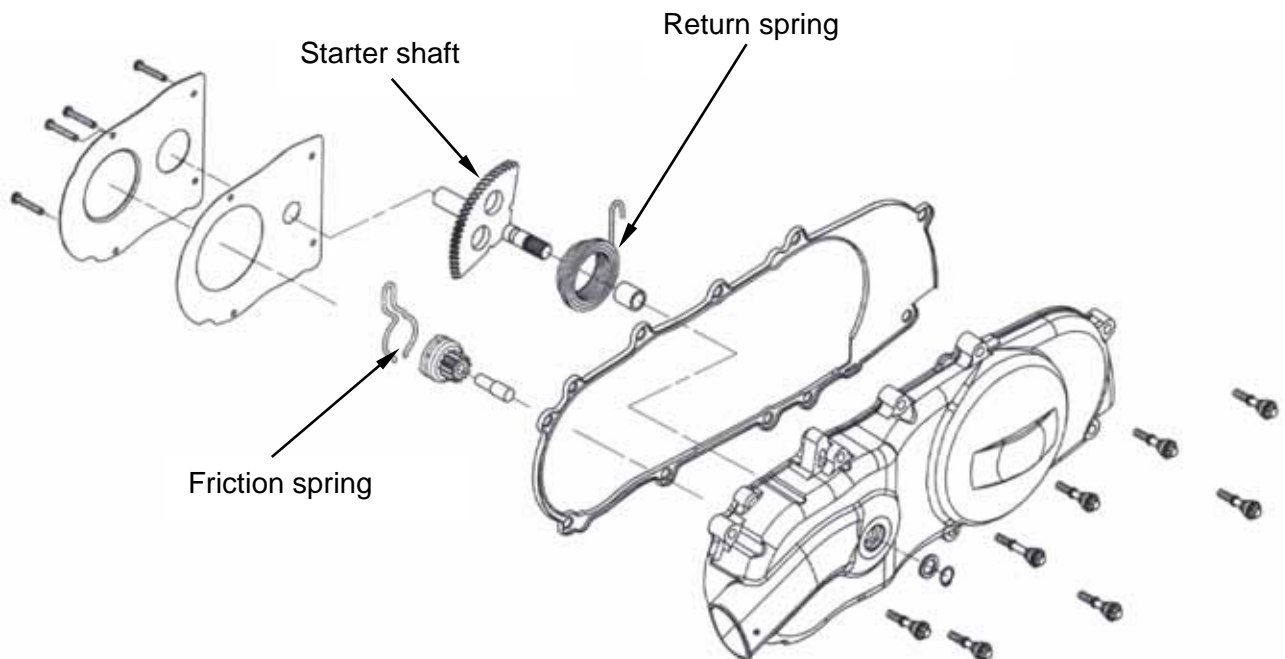

Reassembly of Kick Starter

Install socket, return spring and starter spindle as diagram shown.

Install thrust washer and snap ring onto starter spindle.

Install kick starter arm temporary.

Rotate the arm and then align driven gear with width-tooth on the starter spindle.

Install the friction of driving gear onto convex part of the cover.

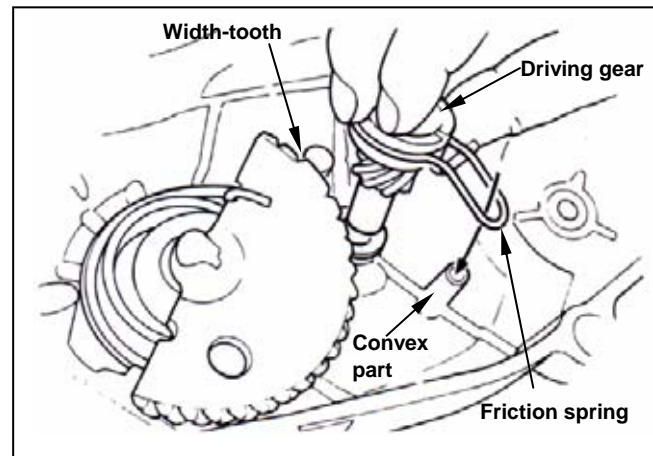
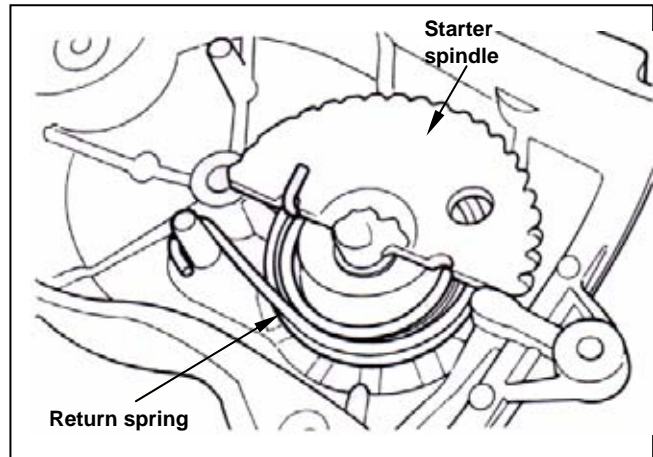

Installation of the left crankcase cover

Install the left crankcase cover

Install kick starter arm

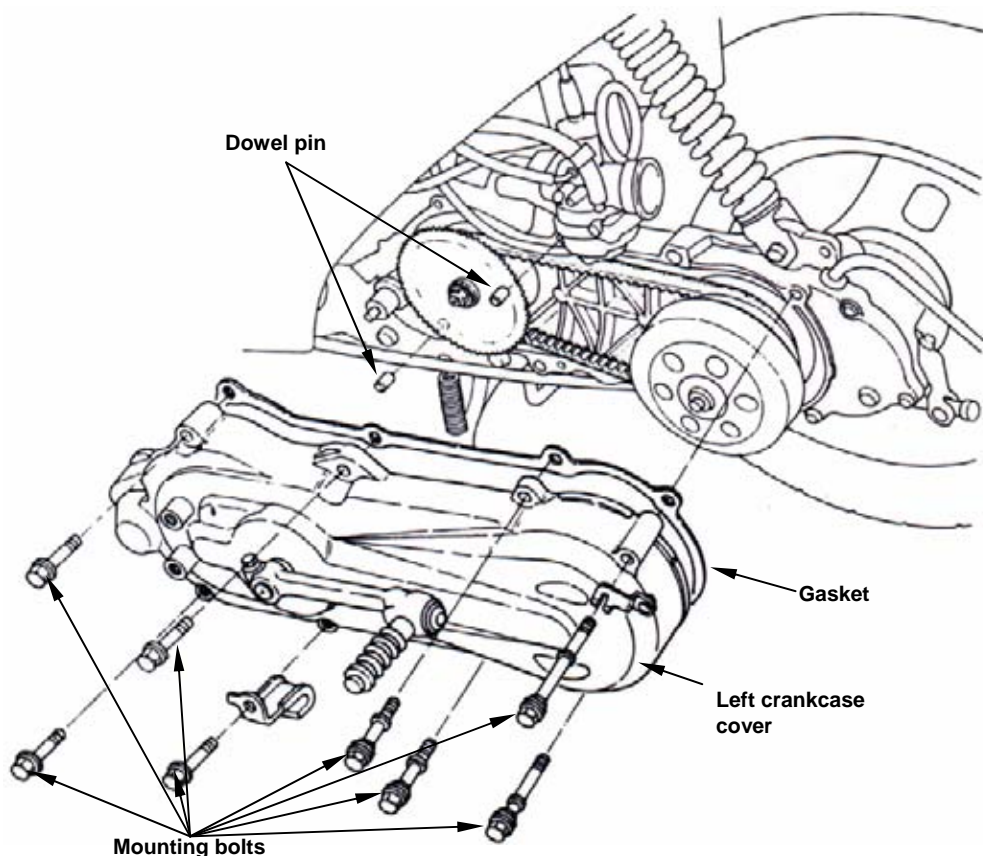

DRIVING BELT

Removal

Remove left crankcase cover
 Hold clutch outer with universal holder, and remove nut and clutch outer.

Caution

- Using special service tools for tightening or loosening the nut.
- Fixed rear wheel or rear brake will damage reduction gear system.

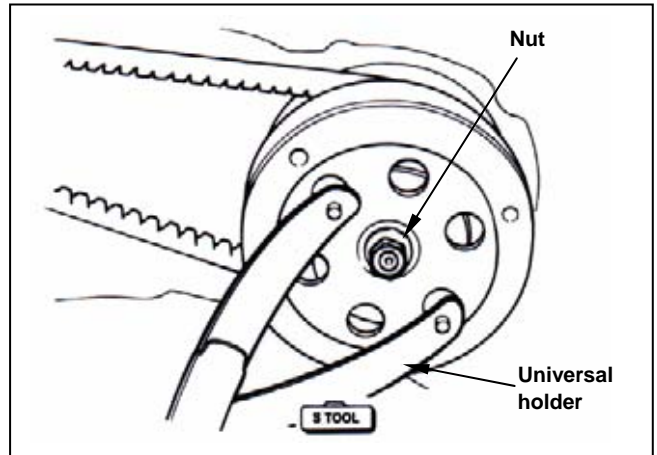

Push the driving belt into belt groove as diagram shown so that the belt can be loosened, and then remove the driven pulley.
 Remove driven pulley. Do not remove driving belt.
 Remove the driving belt from the groove of driven pulley.

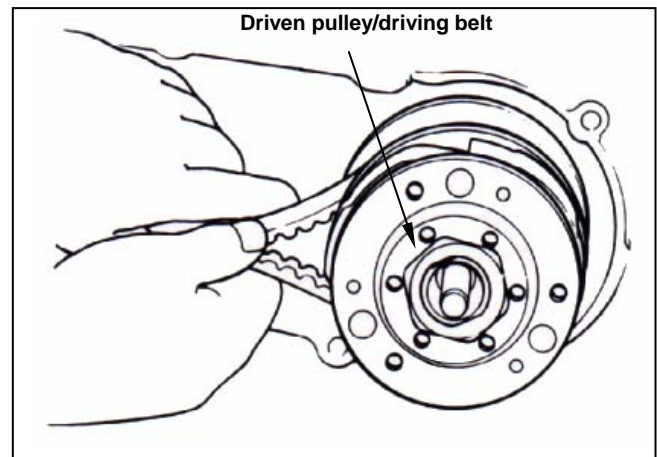

Inspection

Check the driving belt for crack or wear. Replace it if necessary.
 Measure the width of driving belt as diagram shown.

Service Limit: 17.5 mm

Replace the belt if exceeds the service limit.

Caution

- Using the genuine parts for replacement.
- The surfaces of driving belt or pulley must be free of grease.
- Clean up all grease or dirt before installation.

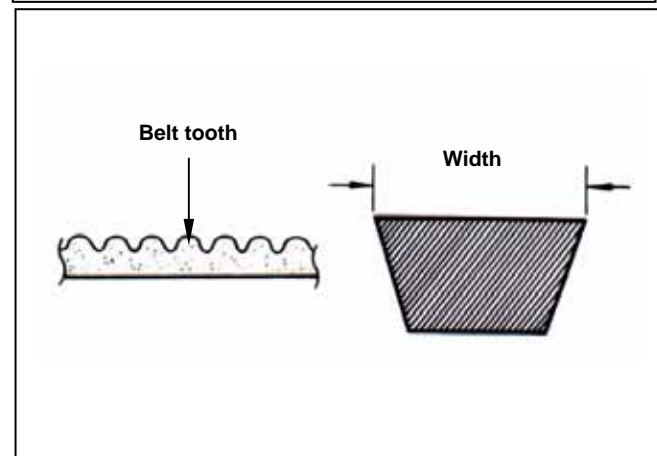

Installation

Caution

Pull out driven pulley to avoid it closing.

Install driving belt onto driven pulley.
 Install the driven pulley that has installed the belt onto drive shaft.

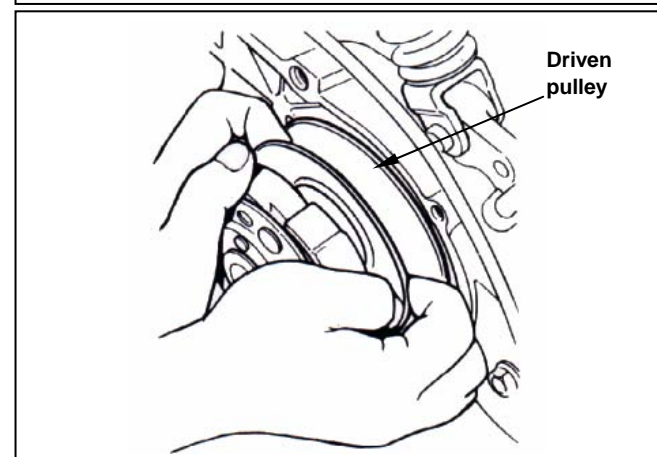

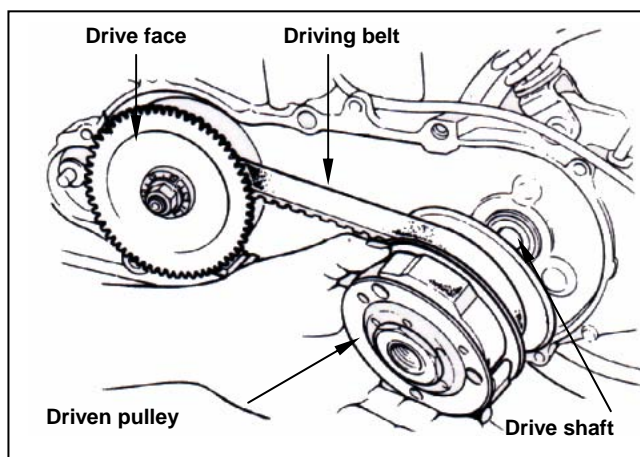

Install the clutch with universal holder, and then tighten nut to specified torque value.

Torque value: 5.0~6.0 kgf-m

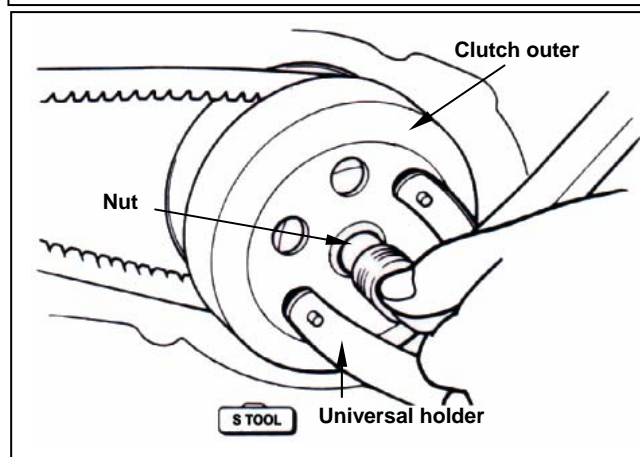

DRIVE FACE

Removal

Remove left crankcase cover.



Hold generator flywheel with universal holder, and then remove drive face nut.
Remove drive face.

Removal

Remove movable drive face comp. and driving belt from crankshaft.

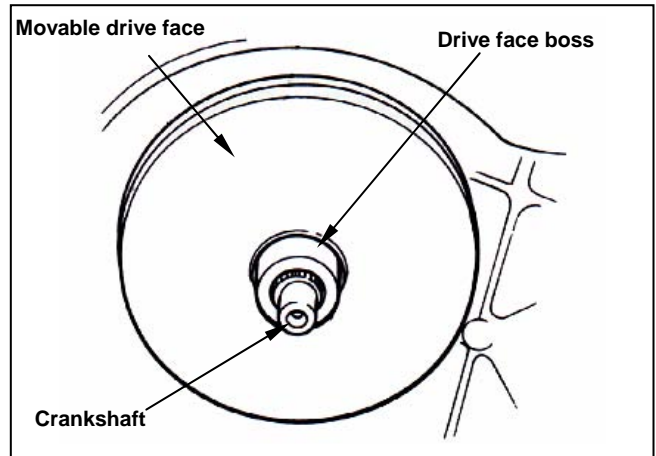

Remove ramp plate.

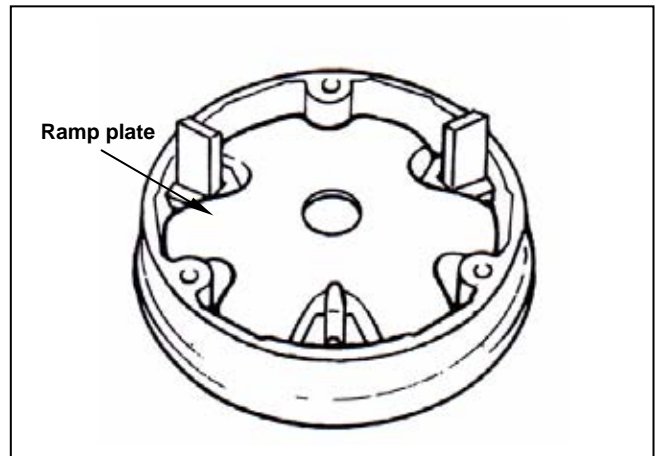

Remove weight rollers from movable drive face.

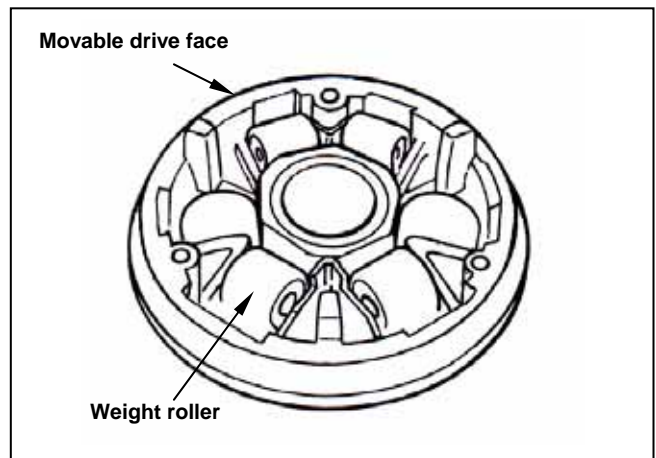

Inspection

The weight rollers are to press movable drive face by means of centrifuge force. Thus, if weight rollers are worn out or damaged, the centrifuge force will be effected.

Check if rollers are wear out or damage.
 Replace it if necessary.
 Measure each roller's outer diameter. Replace it if exceed the service limit.

Service limit: 19.50 mm

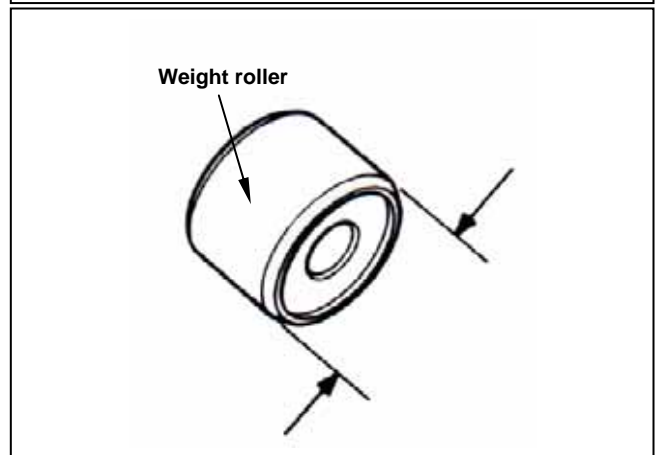

8. V-BELT DRIVING SYSTEM/KICK STARTER



Check if drive face boss is worn or damaged and replace it if necessary.

Measure the outer diameter of movable drive face, and replace it if it exceed service limit.

Service limit: 26.94 mm

Measure the inner diameter of movable drive face, and replace it if it exceed service limit.

Service limit: 27.06 mm

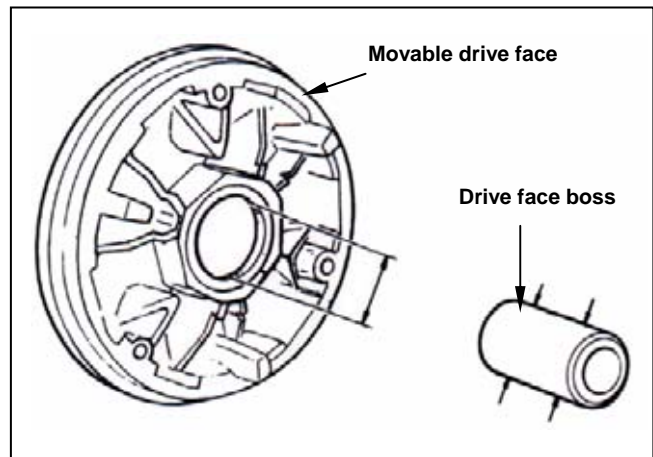

Reassembly/installation

Install weight rollers.

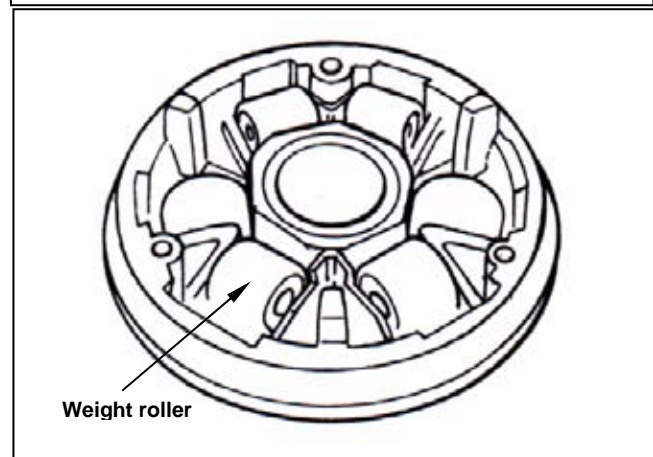

Install ramp plate.

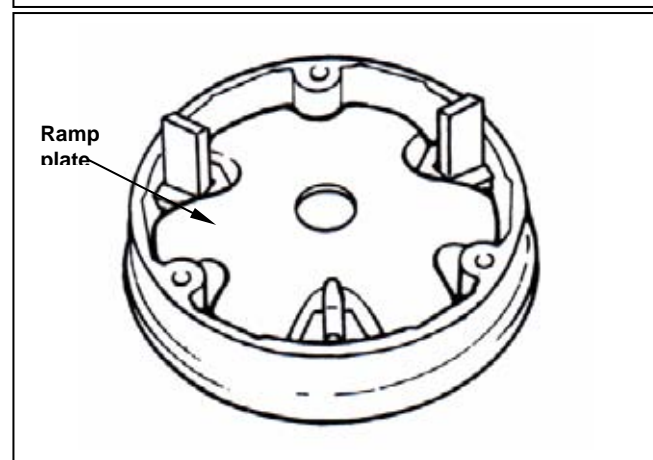

Caution

The movable drive face surface has to be free of grease. Clean it with cleaning solvent.

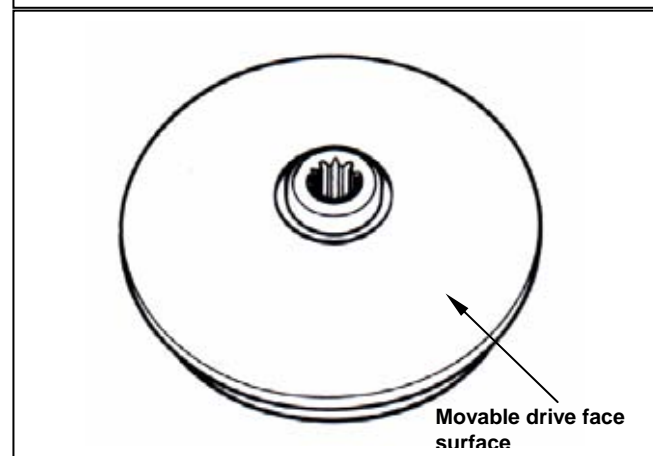

Install movable drive face comp. onto crankshaft.

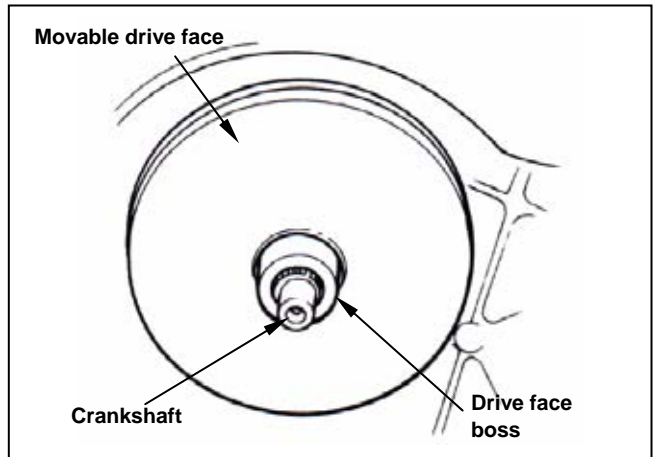

Driven pulley installation

Press driving belt into pulley groove, and then pull the belt onto drive shaft.

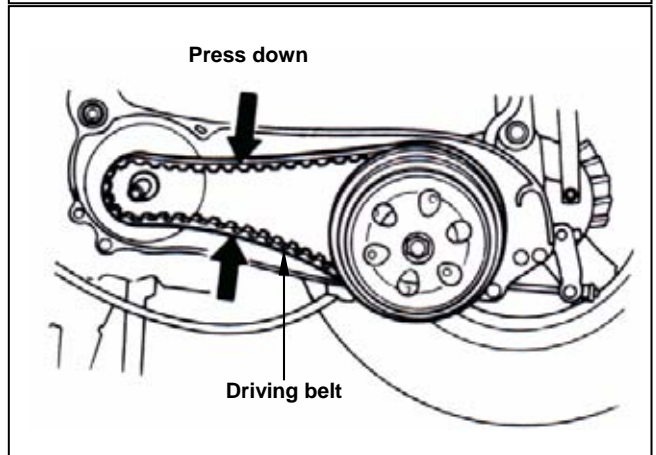

Install driven pulley, washer and nut.

Caution

Make sure that two sides of pulley surfaces have to be free of grease. Clean it with cleaning solvent.

Hold crankshaft with universal holder.



Tighten nut to specified torque.

Torque value: 5.0-6.0 kg-m

Install left crankcase cover.

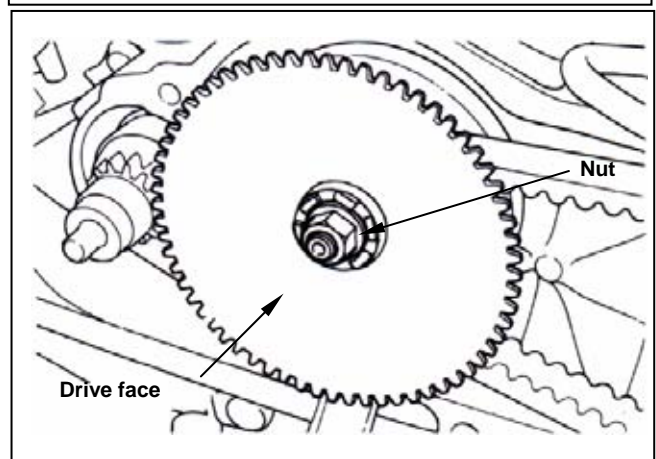

CLUTCH OUTER/DRIVEN PULLEY

Disassembly

Remove driving belt and clutch outer/driven pulley.
 Install clutch spring compressor onto the pulley assembly, and operate the compressor to let the wrench be installed more easily.

⚠ Caution

Do not press the compressor too much.

Hold the clutch spring compressor onto bench vise, and then remove mounting nut with special service tool.
 Release the clutch spring compressor and remove clutch weight and spring from driven pulley.
 Remove collar from driven pulley.

Remove guide pin, guide pin roller, and movable driven face, and then remove O-ring & oil seal seat from movable driven face.

Inspection

Clutch outer

Measure the inner diameter of clutch outer.
 Replace the clutch outer if exceed service limit.
Service limit: 130.5 mm

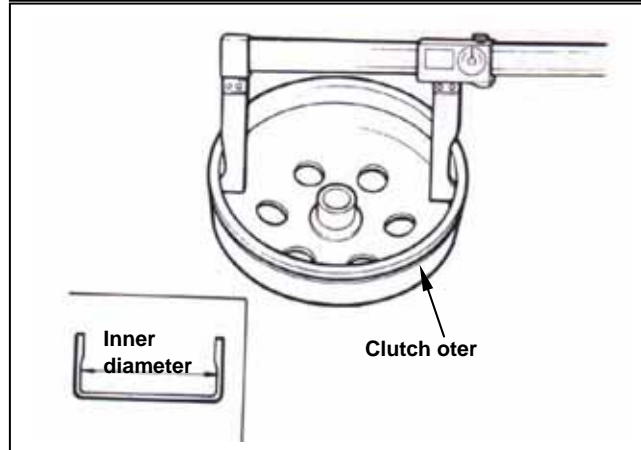
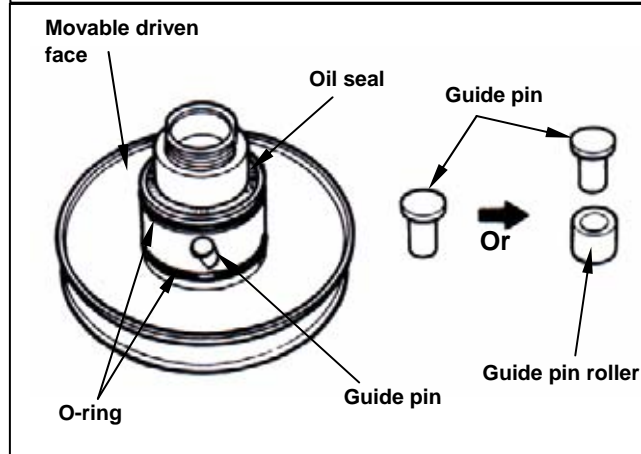
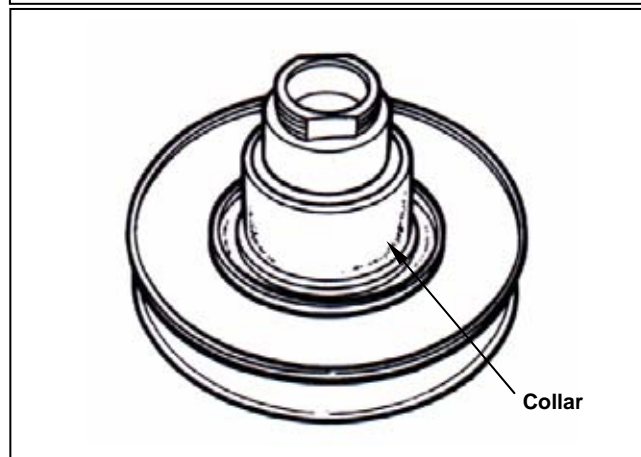
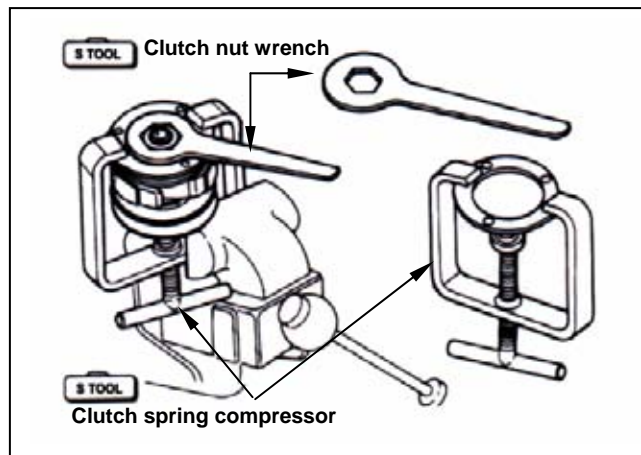

Clutch lining

Measure each clutch weight thickness. Replace it if exceeds service limit.

Service limit: 2.0 mm

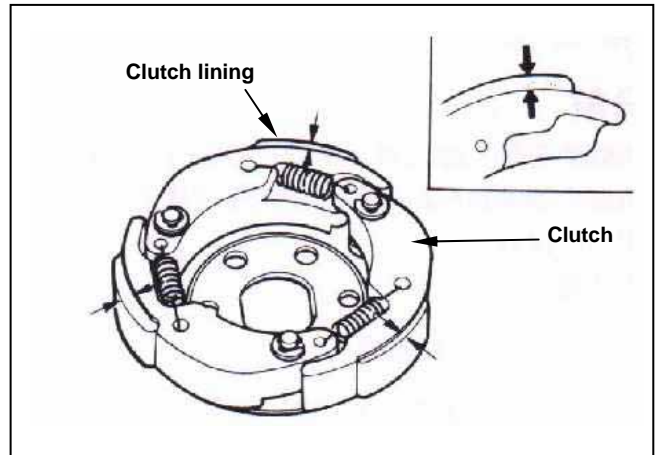

Driven pulley spring

Measure the length of driven pulley spring. Replace it if exceeds service limit.

Service limit: 83.2 mm

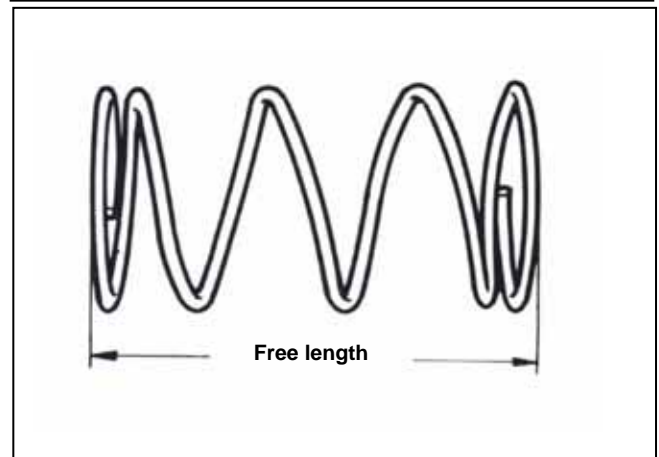

Driven pulley

Check following items:

- If both surfaces are damaged or worn.
- If guide pin groove is damaged or worn.

Replace damaged or worn components.

Measure the outer diameter of driven face and the inner diameter of movable driven face.

Replace it if exceeds service limit.

Service limit: Outer diameter 33.94 mm

Inner diameter 34.06 mm

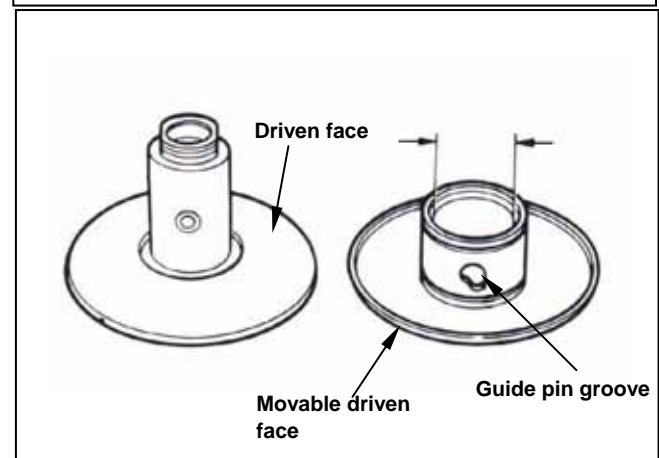

Driven Pulley Bearing Inspection

Check if the inner bearing oil seal is damage. Replace it if necessary.

Check if needle bearing is damage or too big clearance. Replace it if necessary.

Rotate the inside of inner bearing with fingers to check if the bearing rotation is in smooth and silent. Check if the bearing outer parts are closed and fixed. Replace it if necessary.

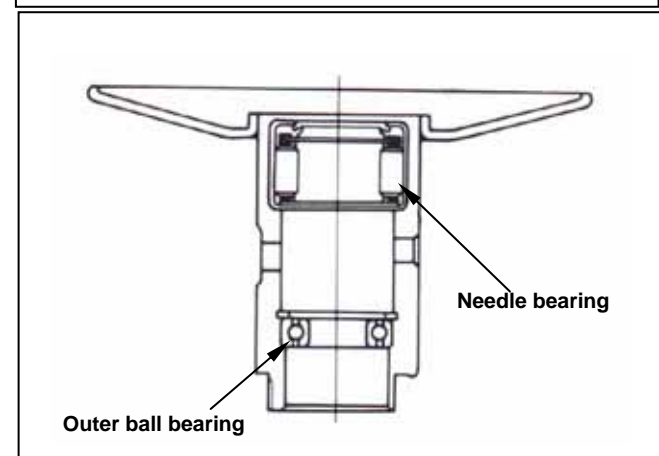

Clutch weight Replacement

Remove snap and washer, and then remove clutch weight and spring from driving plate.

Caution

Some of models are equipped with one mounting plate instead of 3 snap rings.

Check if spring is damage or insufficient elasticity.

Check if shock absorption rubber is damage or deformation. Replace it if necessary. Apply with grease onto setting pins.

Install new clutch weight onto setting pin and then push to the specified location. Apply with grease onto setting pins. But, the clutch block should not be greased. If so, replace it.

Caution

Grease or lubricant will damage the clutch weight and effect the block's connection capacity.

Install the spring into groove with pliers.

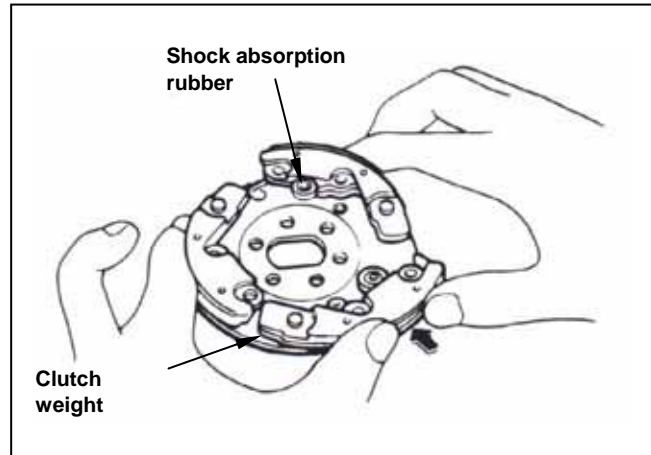
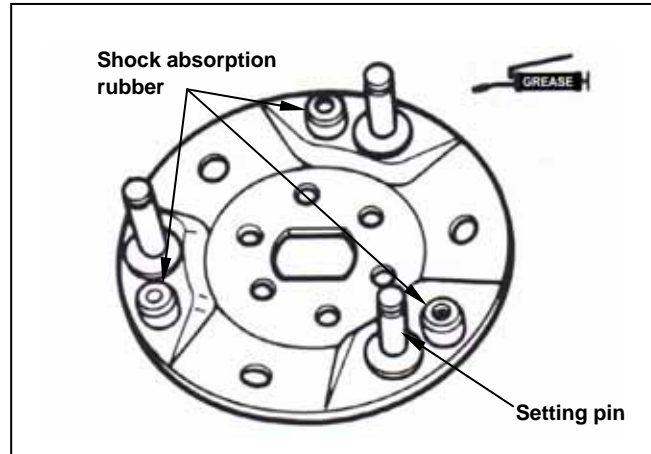
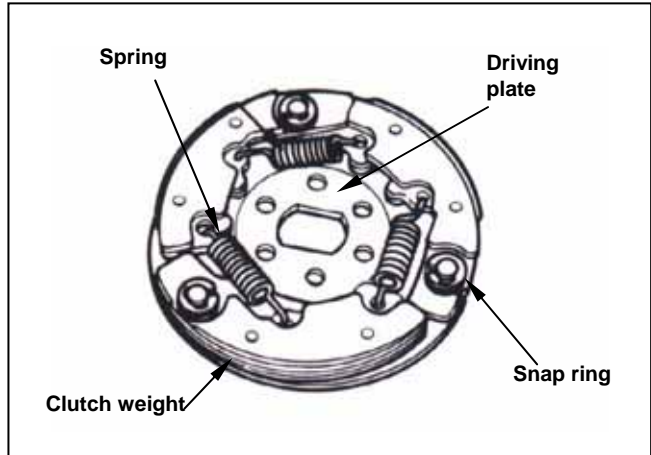

Install snap ring and mounting plate onto setting pin.

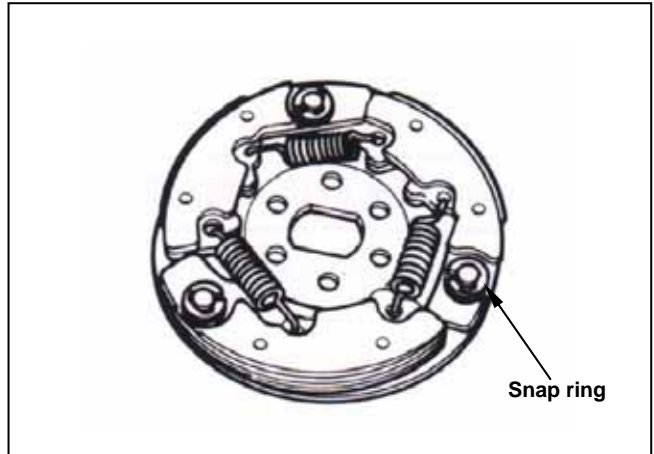

Replacement of Driven Pulley Bearing

Remove inner bearing.

Caution

- If the inner bearing equipped with oil seal on side in the driven pulley, then remove the oil seal firstly.
- If the pulley equipped with ball bearing, it has to remove snap ring and then the bearing.

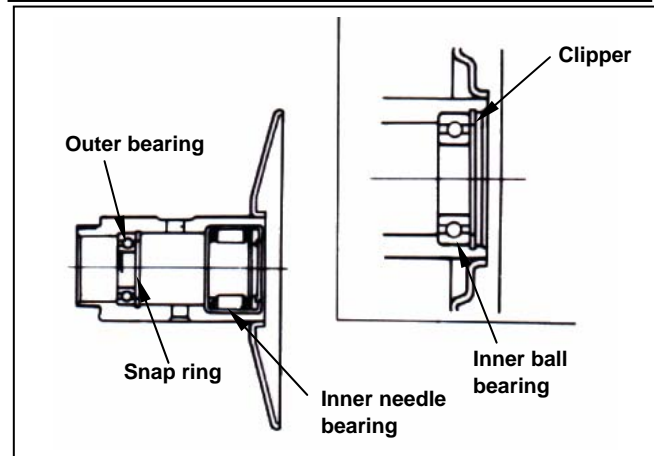

Remove snap ring and then push bearing forward to other side of inner bearing.

Place new bearing onto proper position and its sealing end should be forwarded to outside. Apply with specified oil.

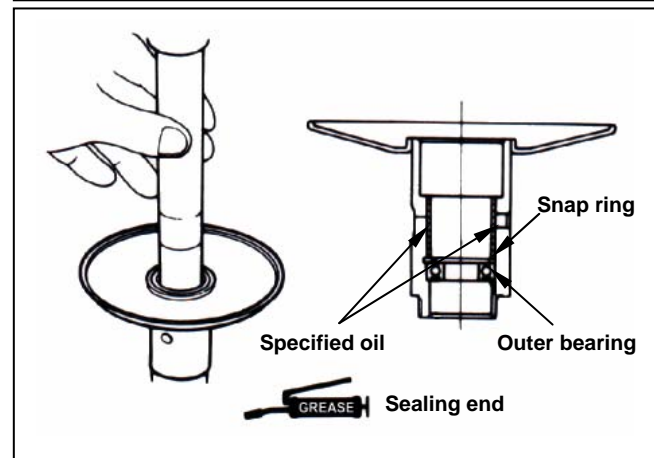

Install new inner bearing.

Caution

- Its sealing end should be forwarded to outside as bearing installation.
- Install needle bearing with hydraulic presser. Install ball bearing by means of hydraulic presser.

Install snap ring into the groove of driving face. Align oil seal lip with bearing, and then install the new oil seal (if necessary).

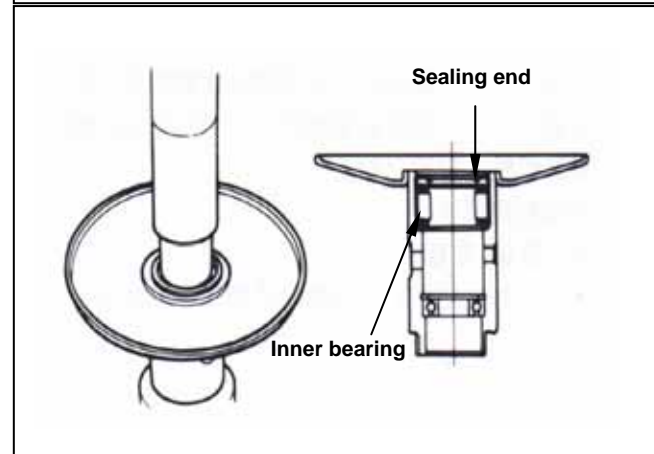

Installation of Clutch OUTER/Driven Pulley Assembly

Install new oil seal and O-ring onto movable driven face.
Apply with specified grease to lubricate the inside of movable driven face..

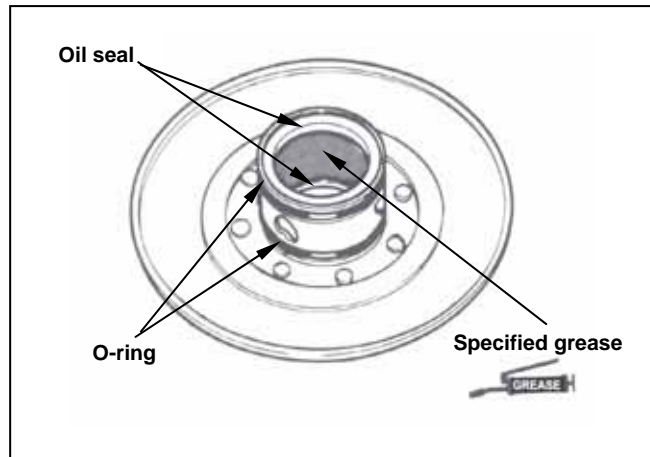

Install the movable driven face onto driven face.
Install the guide pin and guide pin roller.

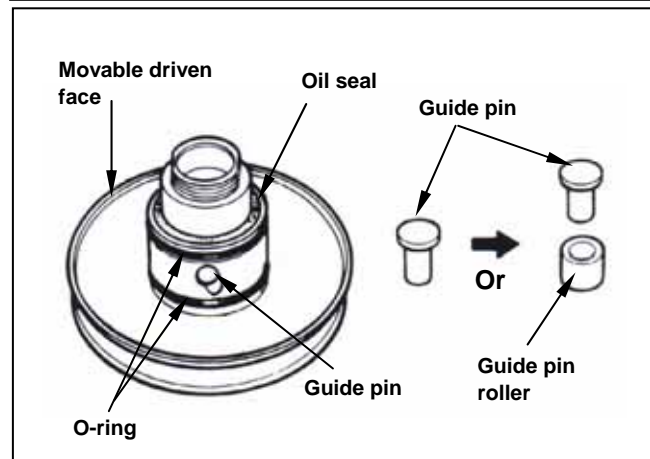

Install the collar.

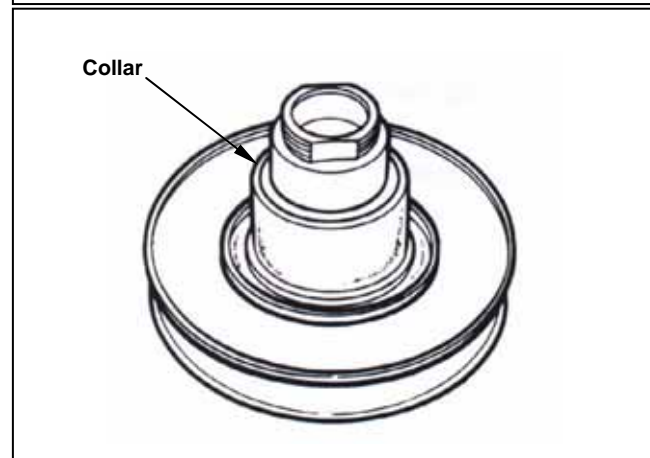

Install driving belt, spring and clutch weight COMP. into clutch spring compressor, and press down the assembly by turning manual lever until mounting nut that can be installed.
Hold the compressor by bench vise and tighten the mounting nut to specified torque with clutch nut wrench.
Remove the clutch spring compressor.
Torque value: 5.0~6.0 kg-m
Install clutch outer/driven pulley and driving belt onto driving shaft.

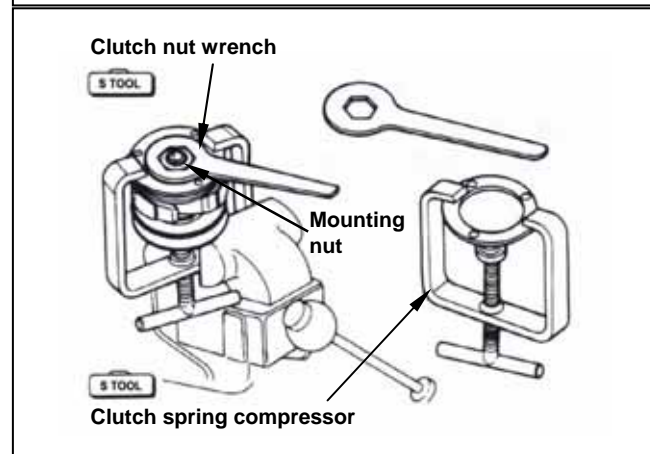

Mechanism Diagram	9-1	Inspection of Final Driving	9-3
Mechanism	9-3	Mechanism	9-3
Precautions in operation	9-2	Bearing Replacement	9-4
Trouble Diagnosis	9-2	Re-assembly of Final Driving	9-6
Disassembly of Final Driving	9-3	Mechanism	9-6
Mechanism	9-3		

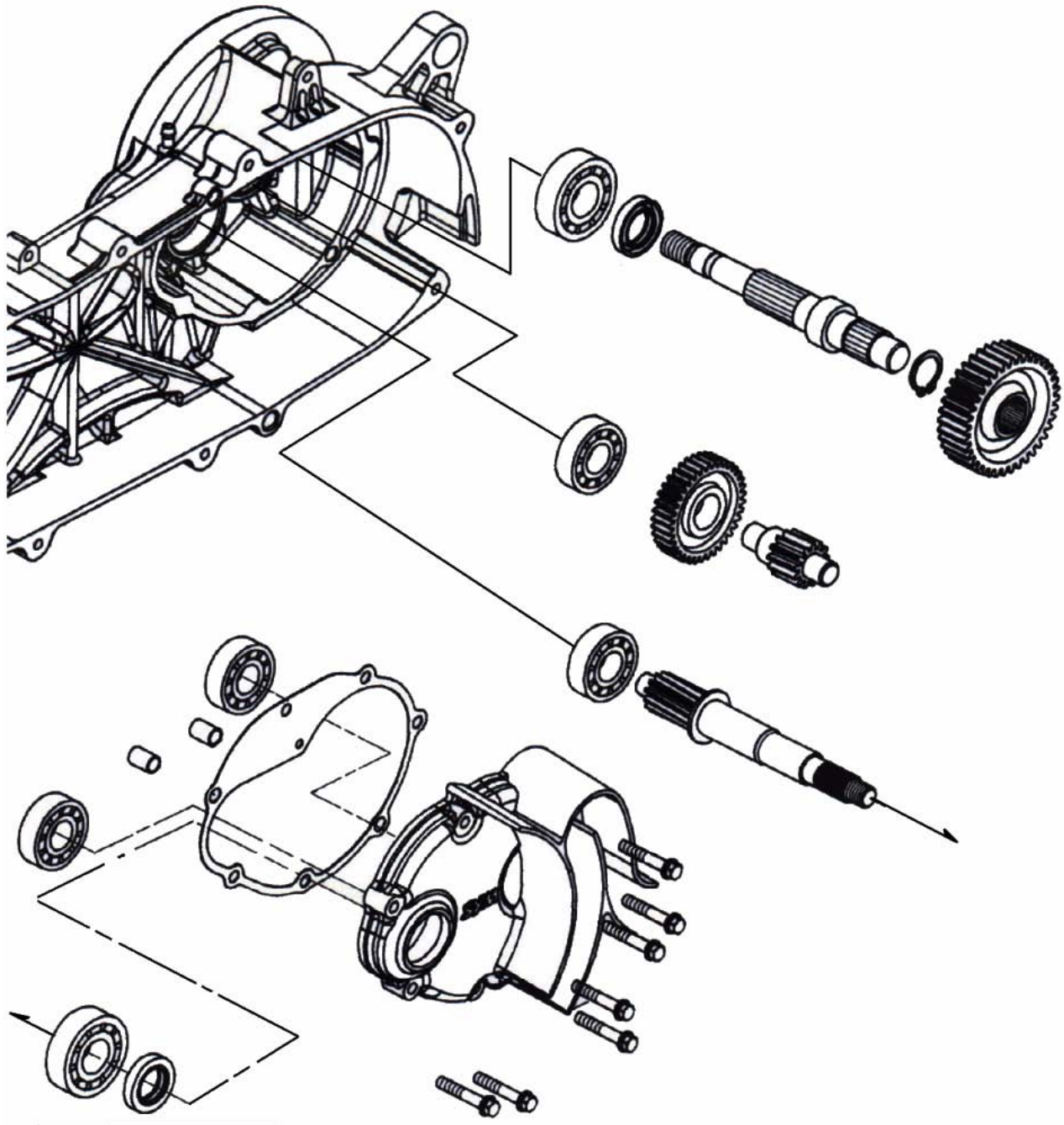

Precautions in operation

Specification

Application oil: scooter gear oil

Recommended oil: KING MATE serial gear oils

Oil quantity: 110 c.c. (100 c.c. when replacing)

Torque value

Gear box cover **1.0~1.4 kg-m**

Tools

Special tools

Bearing (6203/6004UZ) driver

Bearing (6204) driver

Bearing (6301) driver

Oil seal (27*42*7) driver

Oil seal (20*32*6) driver

Inner bearing puller

Outer bearing puller

Trouble Diagnosis

Engine can be started but motorcycle can not be moved.

- Damaged driving gear
- Burnt out driving gear

Noise

- Worn or burnt gear
- Worn gear

Gear oil leaks

- Excessive gear oil.
- Worn or damage oil seal

Disassembly of Final Driving Mechanism

Remove driven pulley.
Drain gear oil out from gear box.
Remove gear box cover bolts and then remove the cover.
Remove gasket and dowel pin.

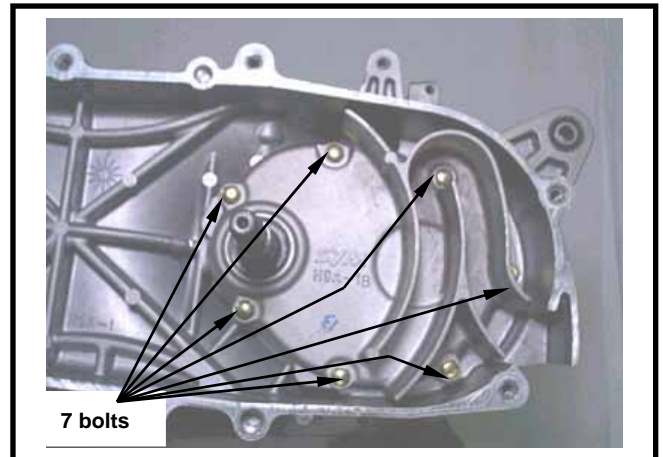

Remove drive shaft.
Remove final driving gear and shaft.
Remove countershaft and gear.

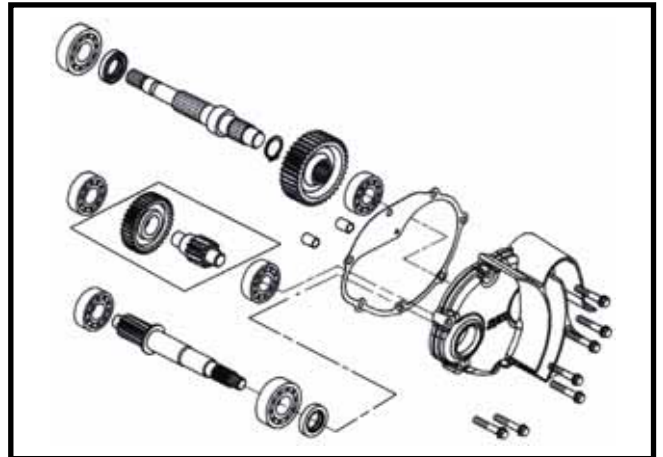

Inspection of Final Driving Mechanism

Check if the countershaft is wear or damage.

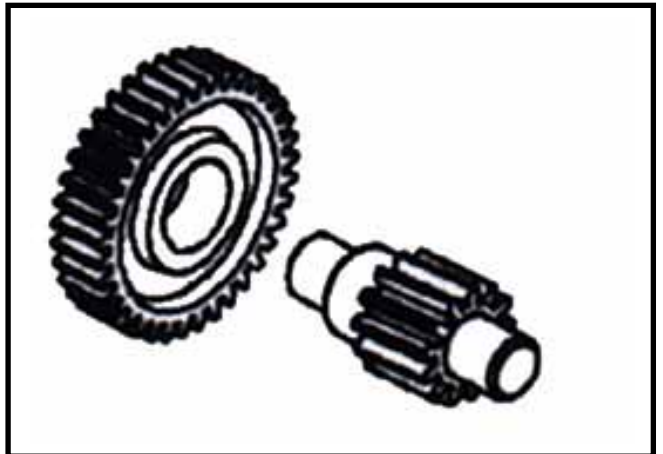

Check if the final shaft and gear are burn, wear or damage.

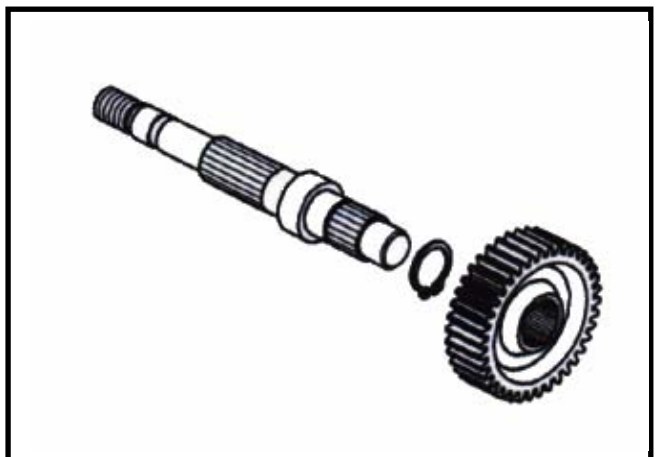

9. FINAL DRIVING MECHANISM



Check bearings on gear box.
Rotate each bearing's inner ring with fingers.
Check if bearings can be turned in smooth and silent, and also check if bearing outer ring is mounted on gear tightly.
If bearing rotation is uneven, noising, or loose bearing mounted, then replace it.
Check oil seal for wear or damage, and replace it if necessary.
Check gear box cover bearing as the same way above, and replace it if necessary.

Caution

- If remove the drive shaft from the cover upper side, then its bearing has to be replaced.

Check drive shaft and gear for wear or damage.

Bearing Replacement

Caution

- Never install used bearings. Once bearing removed, it has to be replaced with new one.

Remove driving shaft bearing from left crankcase using following tools:

Inner bearing puller

Install new driving shaft bearing into left crankcase.

Tool:

Bearing (6301) driver

Press the bearing into cover with hydraulic presser.

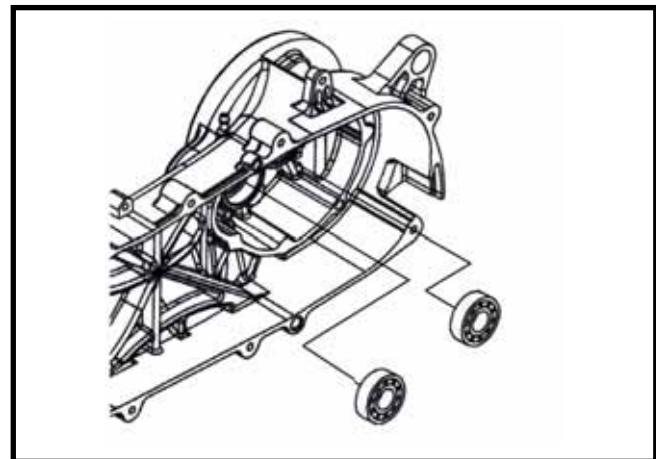
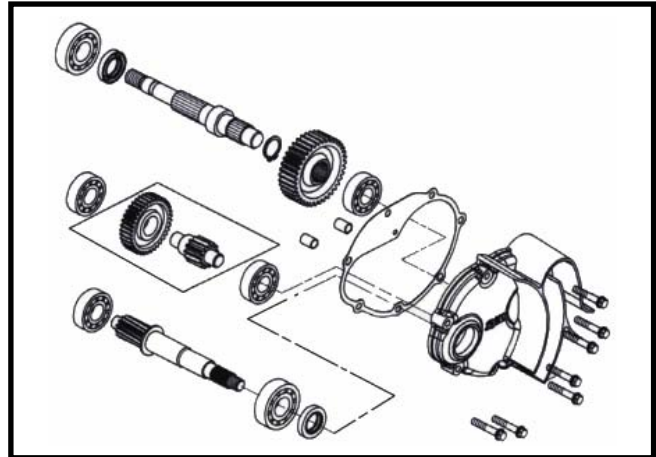

Remove oil seal, and then remove final shaft bearing from left crankcase.
Install new final shaft bearing.
Press the bearing in with hydraulic presser.

Tool:

Bearing (6203/6004UZ) driver

Oil seal (27*42*7) driver

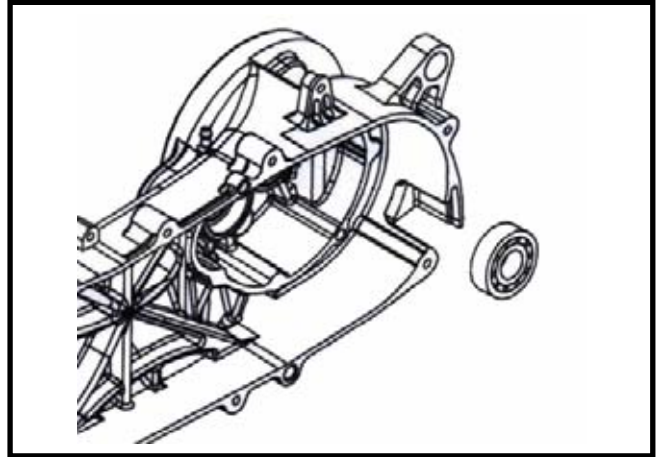

Press out the driving shaft from gear box cover.
Using bearing protector as operation.
Remove oil seal from gear box cover and discard the seal.
Use bearing puller to remove the final shaft bearing from the cover.

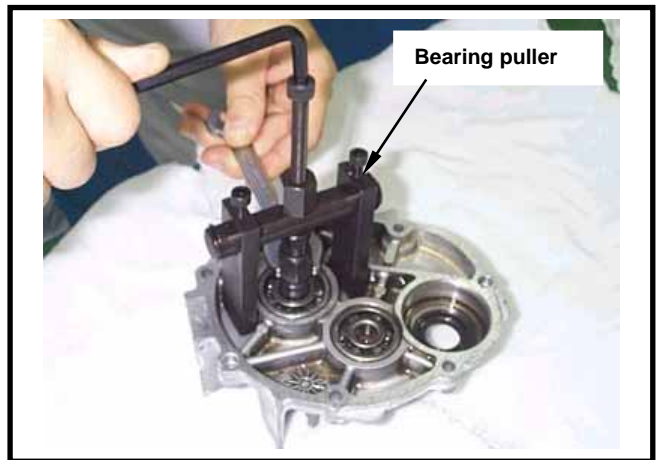

If the driving shaft is pulled out with its bearing, then remove the bearing with bearing puller and bearing protector.

Tool:

Bearing (6204) driver or

Multi-functional bearing puller

Bearing protector

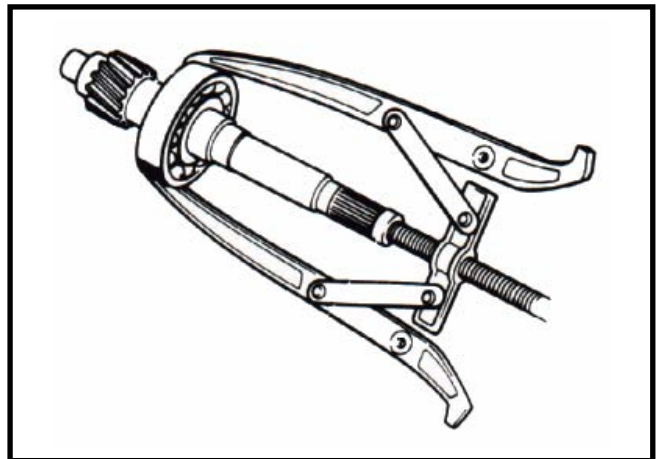

Install a new driving shaft bearing onto gear box cover.

Tool:

Bearing (6204) driver

Press the bearing in with hydraulic presser.



9. FINAL DRIVING MECHANISM



Install a new final shaft bearing onto gear box cover.

Tool:

Bearing (6203/6004UZ) driver

Press the bearing in with hydraulic presser.



Install the driving shaft onto gear box cover and then place it to proper position.

Apply with grease onto new oil seal lip, and then install the oil seal.

Tool:

Oil seal (20*32*6) driver



Re-assembly of Final Driving Mechanism

Apply with grease onto the oil seal lip of final driving shaft.



Install countershaft, final shaft and final driving gear.

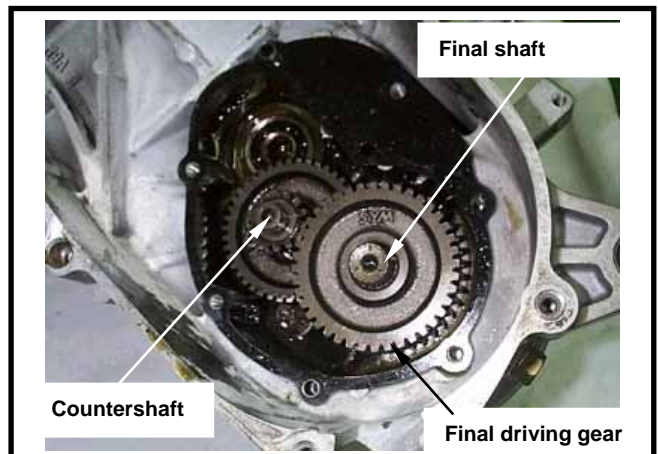

Install dowel pin and new gasket.

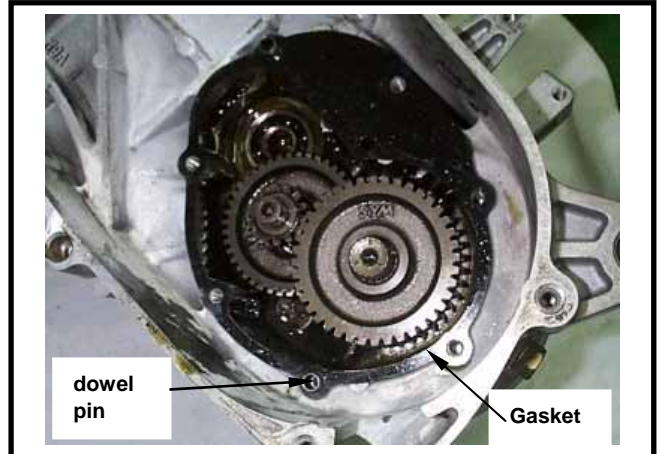

Install gear box cover and bolts, and tighten.
Torque value: 1.0~1.4 kgf-m
Install driven pulley/clutch outer/belt.
Install movable drive face, drive face and left crankcase.
Install rear wheel.
Add gear oil.

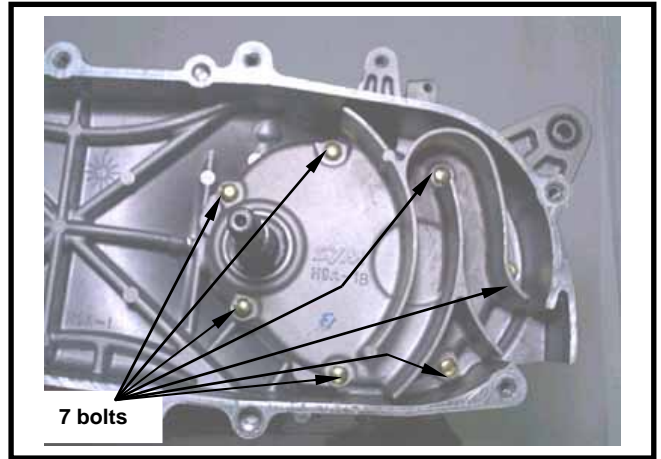

NOTES

Precautions in Operation	10-2	Starting Clutch	10-4
Right Crankcase Cover Removal.	10-3	Flywheel Installation.....	10-7
A.C.G. Set Removal.....	10-3	A.C.G. Set Installation	10-7
Flywheel Removal	10-3	Right Crankcase Installation.....	10-7

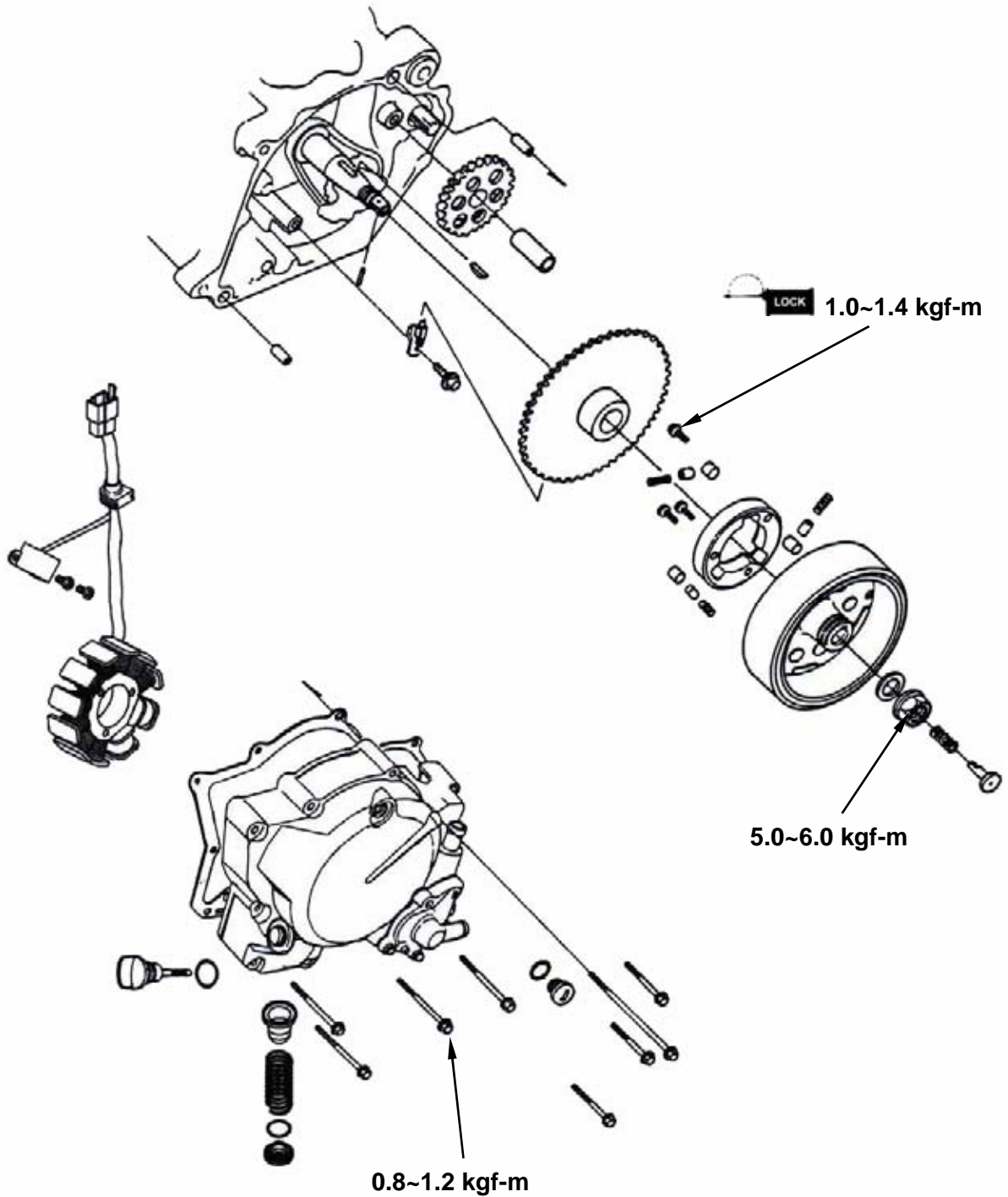

Precautions in Operation

General information

- Refer to chapter 5: Engine removal and installation
- Refer to chapter 16: The troubleshooting and inspection of alternator
- Refer to chapter 16: The service procedures and precaution items of starter motor

Specification

Item	Standard value (mm)	Limit (mm)
ID of starting clutch gear	20.026~20.045	20.100
OD of starting clutch gear	42.175~42.200	42.100

Torque value

Flywheel nut	5.0~6.0 kgf-m
Starting clutch hexagon bolt	1.0~1.4 kgf-m with adhesive
8 mm bolts	0.8~1.2 kgf-m
12 mm bolts	1.0~1.4 kgf-m

Tools

Special tools

A.C.G. flywheel puller
Universal holder

Right Crankcase Cover Removal

Remove 7 bolts from the right crankcase cover.
 Remove the right crankcase cover.
 Remove dowel pin and gasket.



A.C.G. Set Removal

Remove 2 mounted bolts from pulse generator and then remove it.
 Remove 3 screws from right crankcase cover and A.C.G. set.

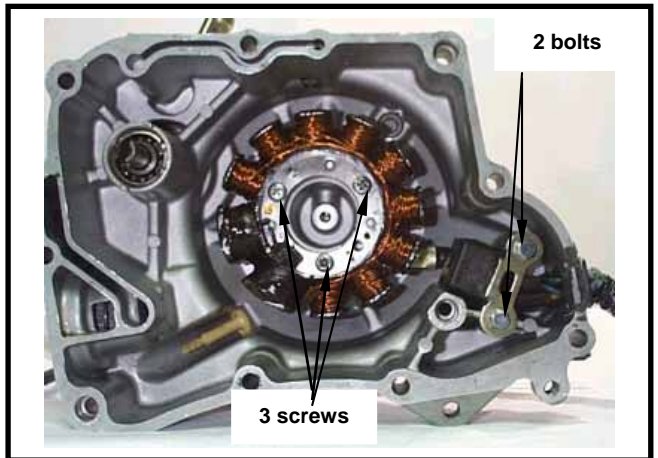

Flywheel Removal

Remove oil through from crankshaft.



Remove the pin from crankshaft.



10. ALTERNATOR/STARTING CLUTCH



Hold flywheel with flywheel holder, and then remove flywheel nut.

Tool:
Multi-functional holder



Pull out flywheel with A.C.G. flywheel puller.

Tool:
A.C.G. Flywheel puller



Starting Clutch

Removal

Remove starting driven gear.



Remove mounting plate, starter reduction gear, and the shaft.



Starting Clutch Inspection

Check the starting clutch gear for wear or damage.

Measure the ID and OD of the starting clutch gear.

Service Limit:

ID: 20.1 mm

OD: 42.10 mm

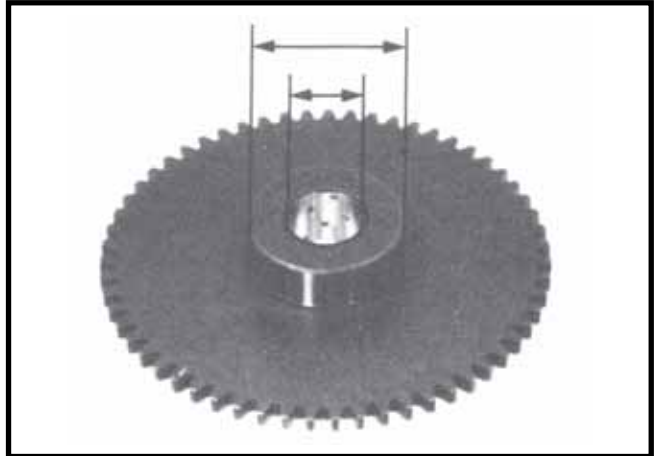

Check the starting reduction gear and shaft for wear or damage.



Install one way clutch onto starting clutch gear. Hold flywheel and rotate starting clutch gear. The starting clutch gear should be rotated in C.C.W direction freely, but not C.W direction. (View as shown in this figure.)

**Disassembly**

Remove 3 hexagon bolts with air and hex socket wrenches.

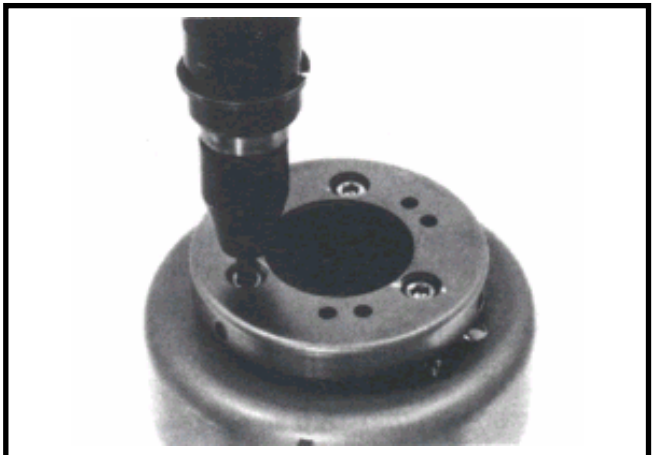

10. ALTERNATOR/STARTING CLUTCH



Remove the rollers, spring caps, and springs of clutch on the one way clutch that located on the back of flywheel.
Check each roller and plug for wear or damage.
Install rollers, plugs and springs.

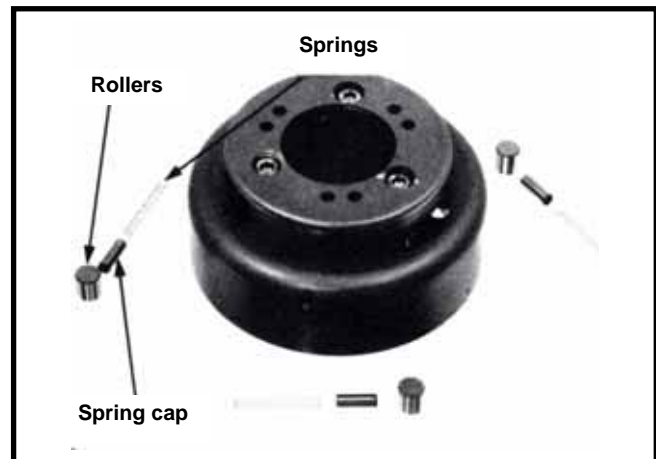

Installation

Install the components in the reverse procedures of removal.



Caution

Tape a tightening tape onto the thread of hexagon bolt.

Torque value: 1.0~1.4 kg-m

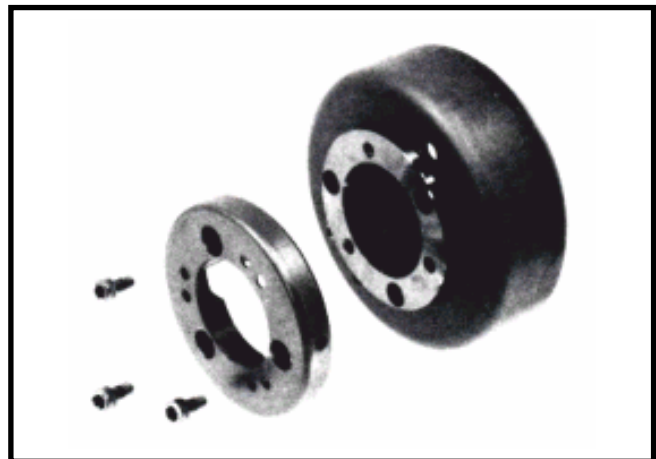

Installation

Install reduction gear shaft and reduction gear.



Install starting clutch gear onto crankshaft.



Flywheel Installation

Insert the pin onto crankshaft.
 Make sure that there is no other material stock on it. If so, clean it up.
 Align the key on crankshaft with the flywheel groove, and then install the flywheel.
 Hold the flywheel with flywheel holder, and tighten its nut.

Torque value: 5.0~6.0 kg-m

Tool:

Flywheel holder
 Install spring and oil through.



A.C.G. Set Installation

Install the A.C.G. set onto right crankcase cover (3 screws).
 Install pulse generator (2 screws).
 Tie the wire harness securely onto the indent of crankcase.

⚠ Caution

Make sure that the wire harness is placed under pulse generator.

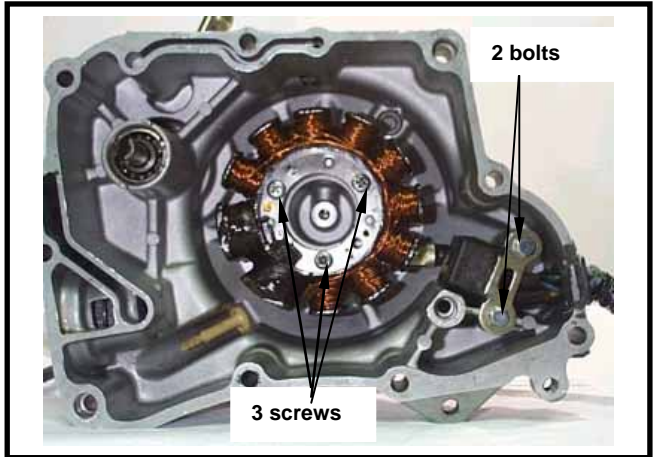

Right Crankcase Cover Installation

Install dowel pin and new gasket.
 Install right crankcase cover onto the crankcase.
 Note that align the water pump shaft indent with the oil pump shaft.
 Install right crankcase cover (9 screws).



Connect water hose to the right crankcase cover.
 Install the water pump cover onto crankcase cover.



NTOES

General information.....11-2	Crankshaft..... 11-5
Trouble diagnosis.....11-2	Assembly of crankcase..... 11-6
Disassembly of crankcase.....11-3	

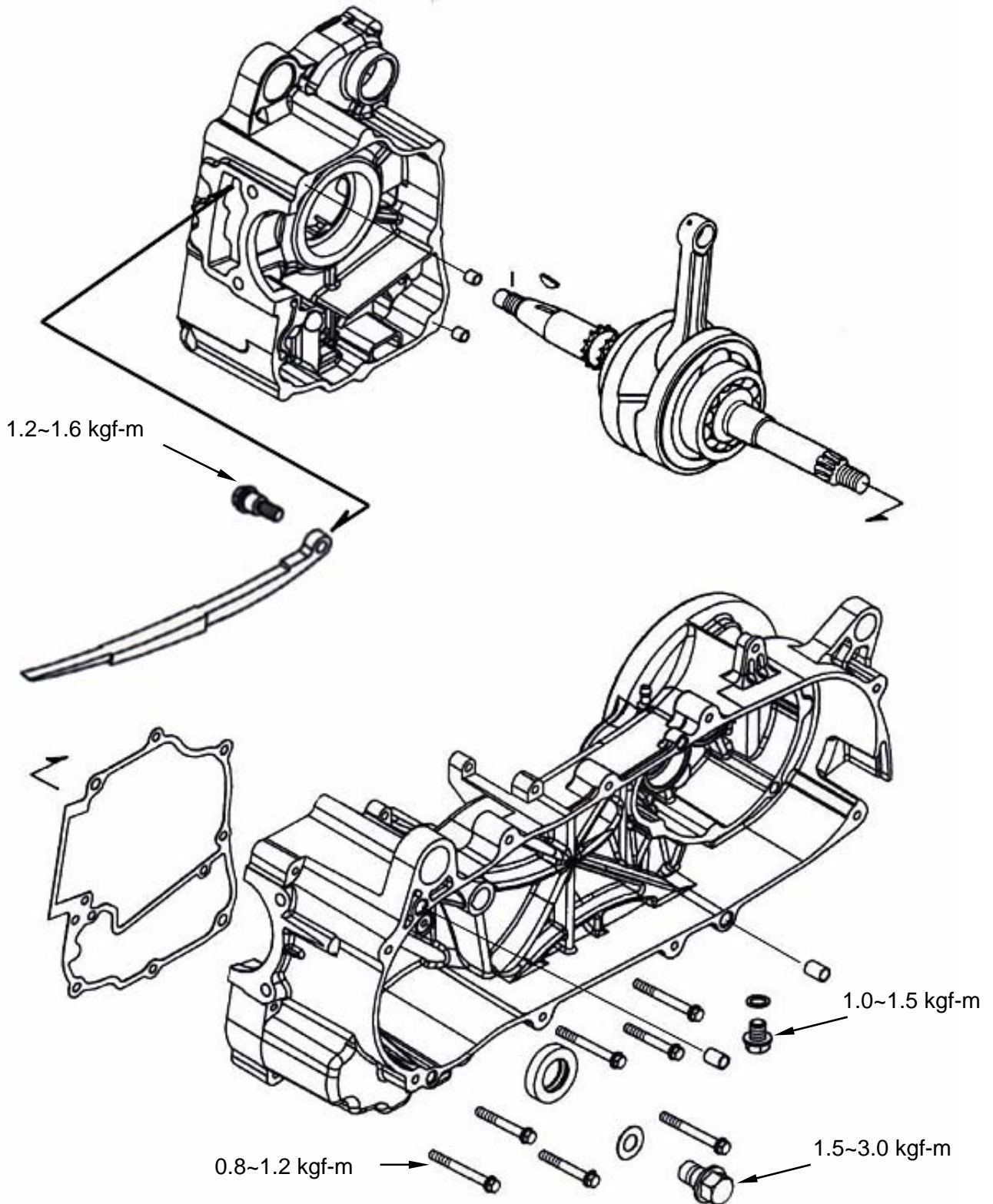

General information

Operational precautions

- This Section concerns disassembly of the crankcase for repair purpose.
- Remove following components before disassembling crankcase.
 - Engine Section 5
 - Cylinder head Section 6
 - Cylinder and piston Section 7
 - Drive pulley and driven pulley Section 8
 - AC generator/Start driven gear Section 10
 - Starting motor Section 16
- In case it requires replacing the crankshaft bearing, the driving chain of engine oil pump or the timing chain, it is preferably to replace crankshaft as a unit.

Service data

Unit: mm

	Item	Standard	Limit
Crankshaft	Connecting rod side clearance of the big end	0.100~0.400	0.600
	Vertical clearance of the big end of the connecting rod	0~0.008	0.050
	Run-out	-	0.100

Torque value

- Bolts for crankcase 0.8~1.2kgf-m
- Bolts for cam chain adjuster 1.2~1.6kgf-m

Tools

Special tools

- R/L. crank disassemble/ install tool
- L. crank shaft bearing driver
- Crank shaft bearing fixing socket
- Crank shaft puller
- Outer bearing puller
- Inner bearing puller

Trouble diagnosis

Engine noise

- Loose crankshaft bearing
- Loose crankshaft pin bearing
- Worn out piston pin and pin hole

Disassembly of crankcase

Remove the cam chain.
Loosen the bolt and remove the tensioner.

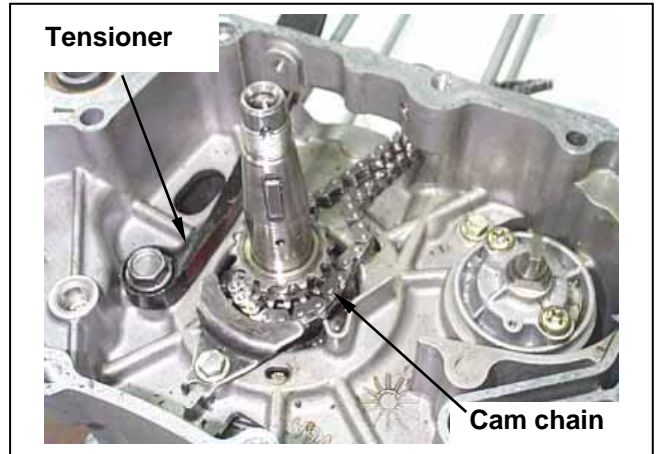

Loosen seven bolts on the crankcase.

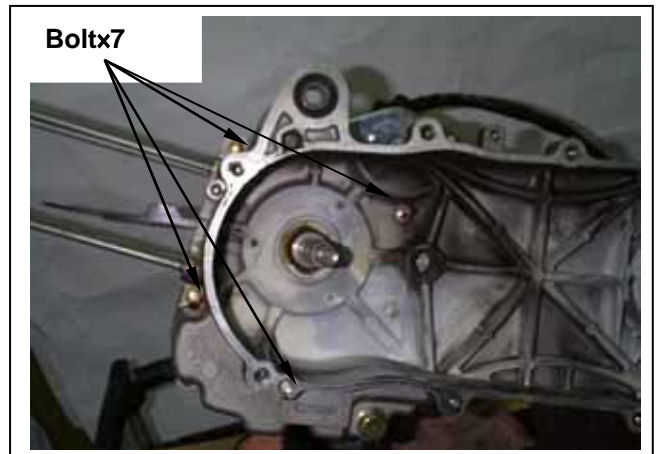

Place right crankshaft case downward and lift up crankcase.

⚠ Caution

- Care should be taken not to damage the contact surfaces.



Refer to chapter 18: Special tools
**Special tool : R/L. crank case
disassemble/install tool
SYM-1120000-H9A**

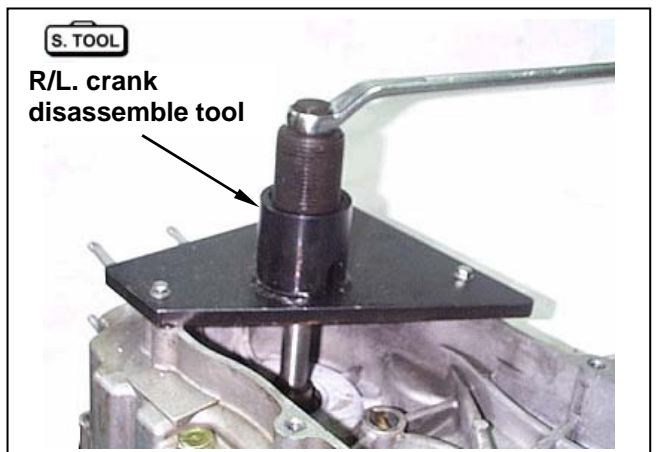

11. CRANKSHAFT/CRANKCASE

Remove crankshaft from right crankcase.



Remove gasket and dowel pins.



Scrape gasket residues off the crankcase contact surface.

⚠ Caution

- Do not damage contact surface of the gasket.
- It is better to moisten the gasket residue for easy scrapping.

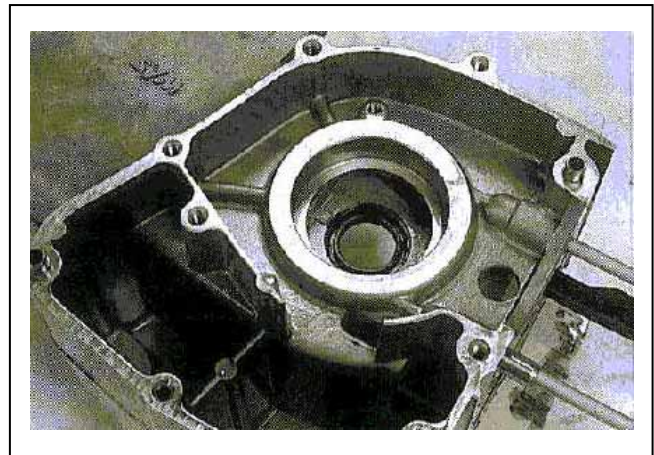

Check any damage in oil seal.
Replace with new one if damaged.

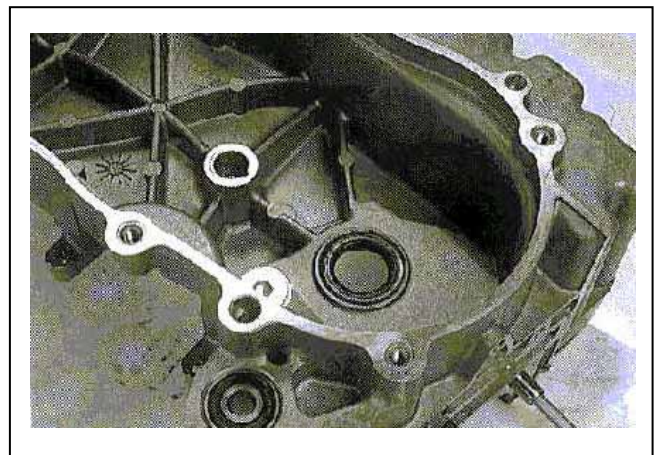

Crankshaft

Use a thickness gauge to measure left and right clearance of connecting rod big end.

Service limit: 0.6 mm

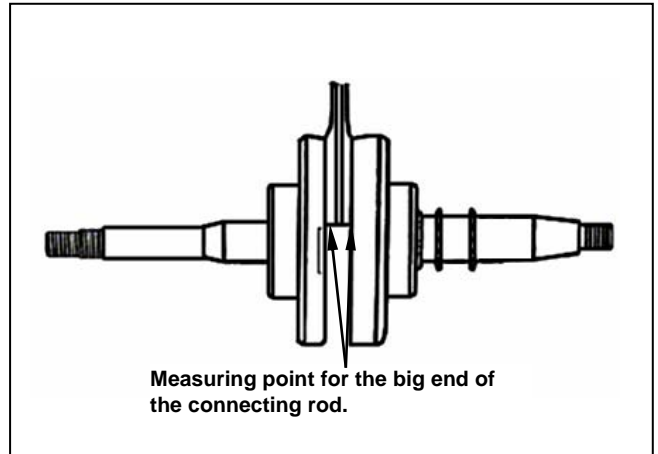

Measure the clearance of the big end at the vertical directions.

Service limit: 0.05 mm

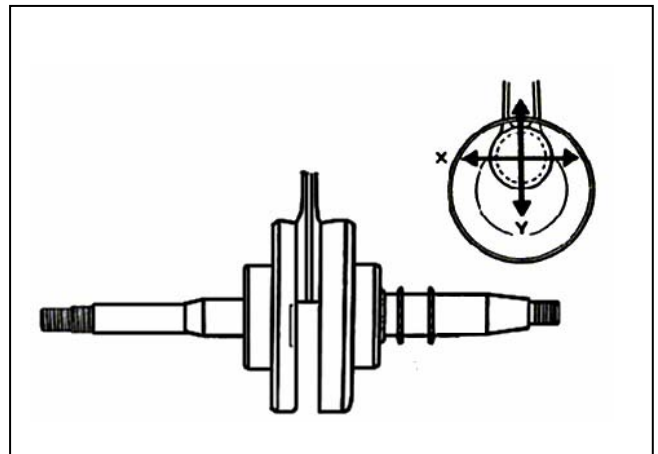

Place the crankshaft on a V-block, measure run-out of the crankshaft.

Service limit: 0.10 mm

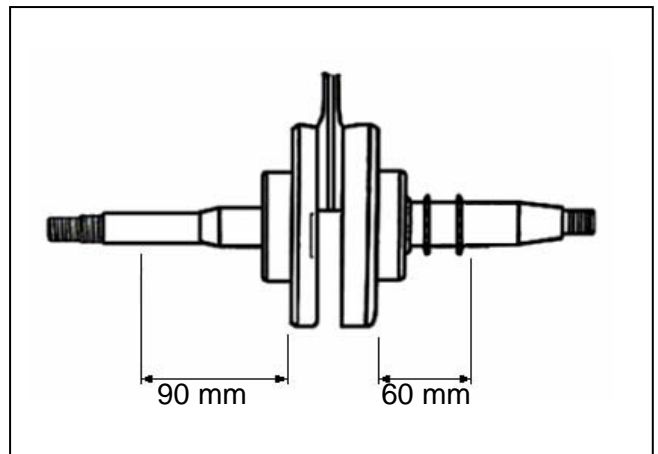

Checking crankshaft bearing.

Use hand to crank the bearing to see it moves freely, smoothly and noiseless.

Check the inner ring to see it links firmly on the bearing.

If any roughness, noise and loose linkage are detected, replace the bearing with new one.

⚠ Caution

- The bearing shall be replaced in pair.

**Special tool : outer bearing puller
SYM-6204010**

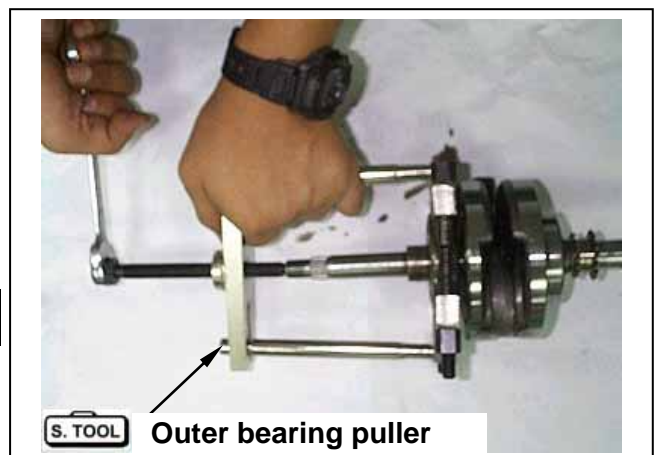

11. CRANKSHAFT/CRANKCASE



Assembly of crankcase

Install a new bearing onto the left crankcase.

- Special tool : left crank shaft bearing driver
SYM-9100200-H9A
- R/L. crank case
disassemble/install tool
SYM-1120000-H9A
- Crank shaft puller
SYM-11130000-H9A
- Clutch nut wrench
SYM-9020200

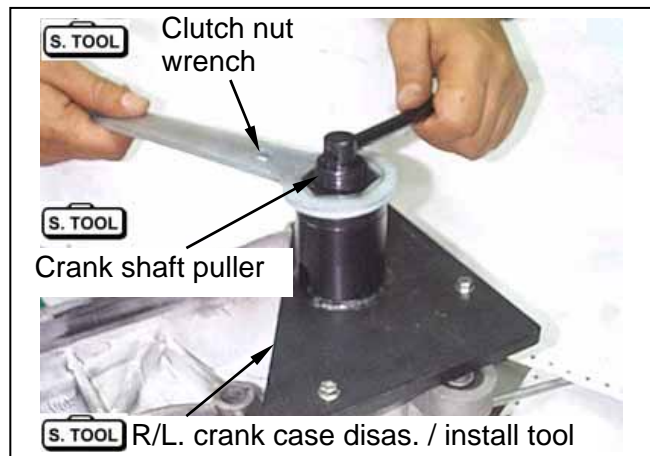

Install crank shaft onto the left crankcase.

- Special tool : R/L. crank case
disassemble/install tool
SYM-1120000-H9A
- Crank shaft puller
SYM-11130000-H9A
- Crank shaft bearing fixing socket
SYM-9100210
- Clutch nut wrench
SYM-9020200



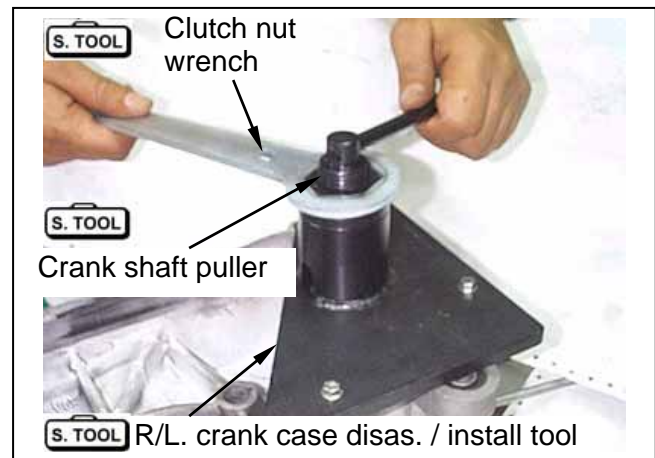
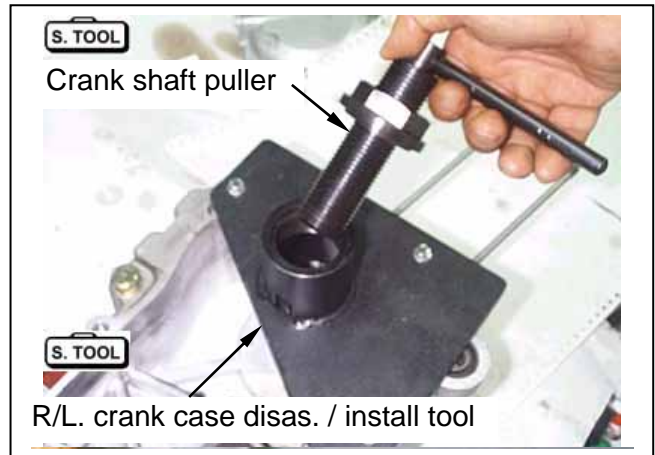

Install new dowel pin and new gasket.

Install the right crankcase onto the left crankcase.



Tighten seven bolts on the crankcase.

Torque value: 0.8~1.2 kgf-m

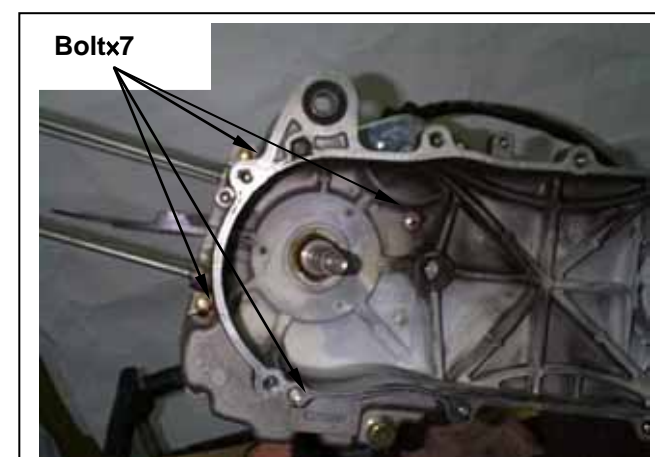

11. CRANKSHAFT/CRANKCASE

Install the new oil seal.
Apply a layer of grease on the lip of oil seal.
Clean the crankshaft with clean solvent.

Special tool :

Oil seal driver (25*40*8)

SYM-9121600

Install the oil seal in the left crankcase with care
not to damage the lip of the oil seal.



Install the tensioner and tighten the bolts.

Torque value: 1.2 ~1.6 kgf-m

Install the cam chain.

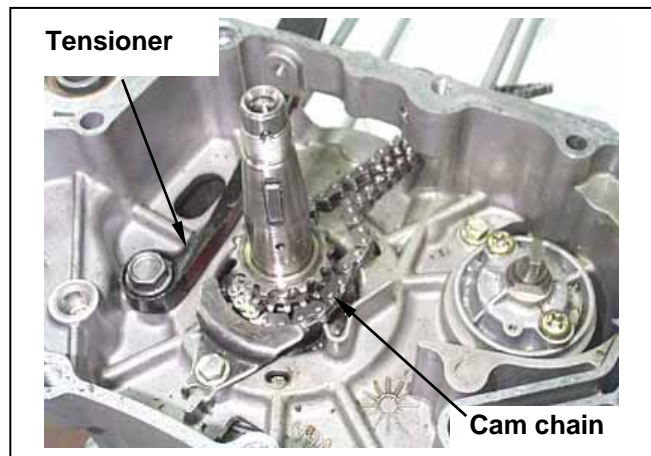

General Information.....	12-2	Radiator.....	12-5
Trouble Diagnosis.....	12-3	Water Pump	12-6
System Test.....	12-4	Temperature sensor.....	12-10
Change of coolant.....	12-4	Thermostat.....	12-11

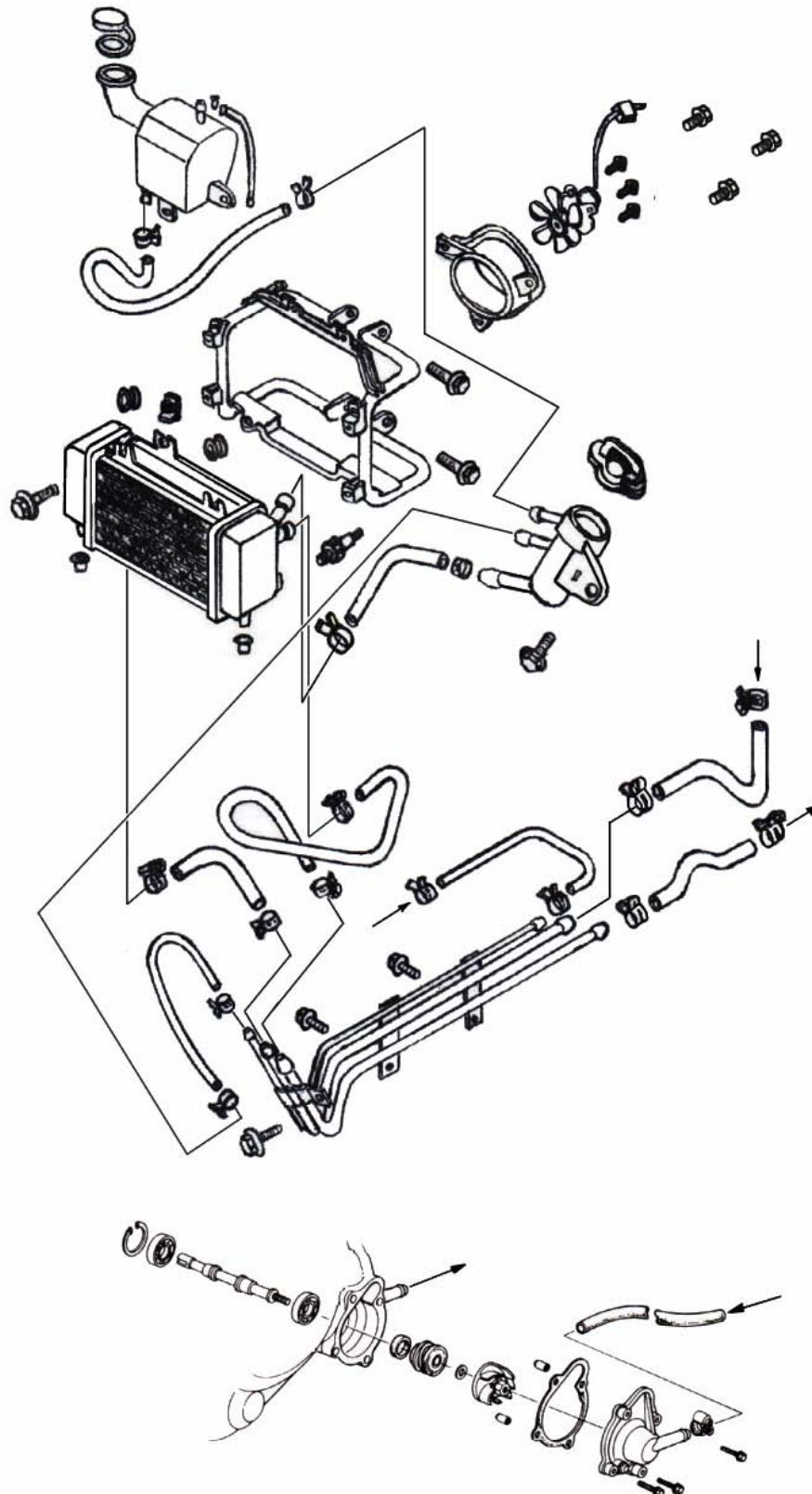

一般情報

General

警告:

- エンジン始動中はラジエーターキャップのふたを開けないで下さい。加圧されたクーラントが飛び出して火傷を負う危険性があります。メンテナンス時はエンジンが冷えるまで待ってから作業して下さい。

- Refill the radiator with distilled water or specified additives.
- Add coolant to the reservoir.
- The cooling system can be serviced on the motorcycle.
- Never spill the coolant to the painted surface.
- Test the cooling system for any leakage after the repair.
- Please refer to Section 17 for inspection of the temperature sensor switch for the fan motor and the water thermometer.

Technical Specification

Item	Specification
Pressure to open filler cap	0.75~1.05 kg/cm ²
Capacity of coolant:	Engine + radiator 780 c.c. Reservoir upper 420 c.c.
Thermostat	Begins to activate at 71-80°C Stroke: 3.5 ~ 4.5 mm/80°C
Boiling point	Not-pressure: 107.7°C Pressurized: 125.6°C

Torque Value

For water pump rotor 1.0~1.4kgf-m

Tools Requirement

Special tools

Water pump bearing driver (6901)
Water pump oil seal driver (Inner)
Water pump mechanical seal driver
Inner bearing puller

Trouble Diagnosis**The engine temperature is too high**

- The water thermometer and the temperature sensor do not work properly.
- The thermostat is stuck to closed.
- Insufficient coolant.
- The water hose and jacket are clogged.
- Fan motor malfunction.
- The filler cap of the radiator malfunction.

The engine temperature is too low

- The water thermometer and the temperature sensor malfunction.
- The thermostat is stuck to open.

Coolant is leaking

- The water pump mechanical seal does not function properly.
- The O ring is deteriorated.
- The water hose is broken or aged.

System Test

Test on the filler cap

Hermetically seal the filler cap, apply water and pressure to the filler cap. Replace it with new one if found failing to maintain the specified pressure within a given time limit, or the opening pressure is too high or too low. The specified pressure shall be maintained at least for 6 seconds in the test

Relief pressure for the filler cap: 0.75-1.05 kg/cm²

Apply pressure to the radiator, engine and water hose to check for any leakage

Caution

Pressure which is too high may damage the radiator. Never use pressure which exceeds 1.05 kg/cm².

If the system fails to maintain the specified pressure for at least 6 seconds, repair or replace parts.

Change of coolant

Warning

Never attempt to carry out service work on the cooling system unless the engine is completely cooled down, otherwise, you may get scalded.

Remove the filler cap cover and the filler cap. Place a water pan under the water pump, loosen the drain bolt to drain out the coolant. Reinstall the drain bolt.

Refilling system with coolant and bleeding the air bubbles.

- Run the engine until the coolant surface becomes stable and there is bubble coming out.
- Stop the engine. Add coolant to proper level if necessary.
- Screw and tighten up the filler cap.

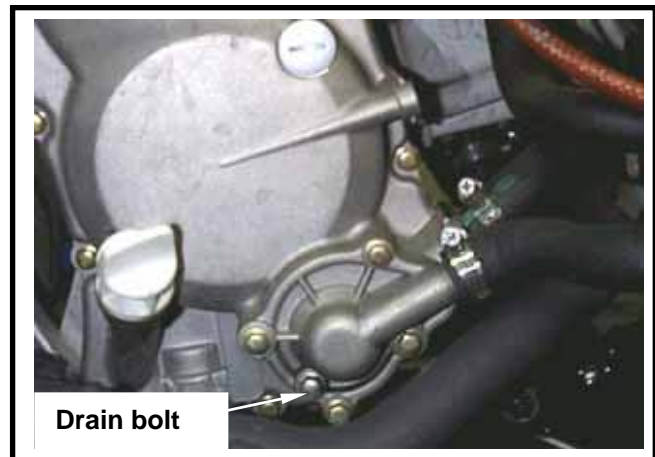
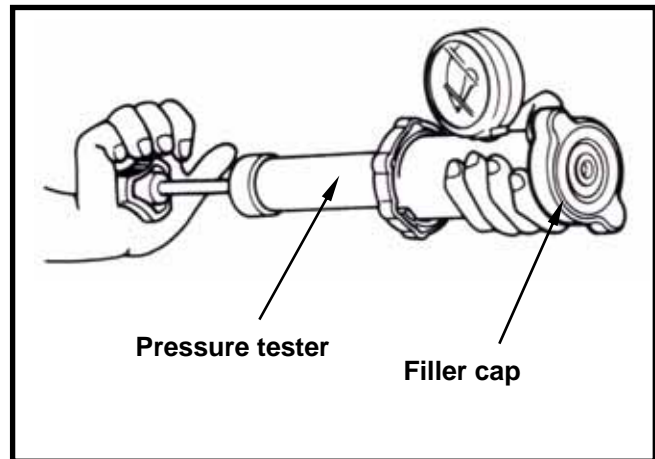

Removing the reserve tank filler cap.

- Check the liquid level in the reservoir. Add coolant to proper level if too low.
- Reinstall the reserve tank filler cap.



Radiator

Removal

Remove the front guard, check for any leakage from weld seam.

Blow cooling fan clean using compressed air. If the cooling fan is blocked by dirt, use low pressure water jet to clean it.

Care shall be taken when straightening the sink fan.



Coolant leakage



Loosen 2 nuts and 4 screws.

Remove the front mudguard by pulling it forward.

Cooling fan coupler

Thermostat coupler



Loosen the hose clamp and remove the upper water hose.
Disconnect the connectors for the thermostat and fan motor.
Loosen the hose clamp and remove the lower water hose.
Disconnect the horn.
Loosen four screws and air duct.
Remove radiator and the fan motor.

Disassembly

Loosen the lock bolt from the fan and remove the fan.
Loosen three screws from the fan motor, and take off the fan motor.

Assembly

Install shroud onto fan motor and insert the fan into the motor shaft.
Apply a coat of the adhesive to the shaft thread of the motor, then install the washer and the lock nut.
Tighten the fan shroud onto the radiator with four bolts. Please refer to Page 16-20 for the inspection of the temperature sensor switch.

Caution

Liquid packing must be applied to the temperature sensor switch before installing to avoid damaging the radiator.

Install the removed parts in the reverse order of removal.

Installation

Install radiator in the reverse order of removal.
Upon completion, check for any leakage.

Water Pump

Inspect the mechanical seal.
Check mechanical seal inspection holes for any leakage.
If there is leakage, remove the right crankcase to replace the mechanical seal.

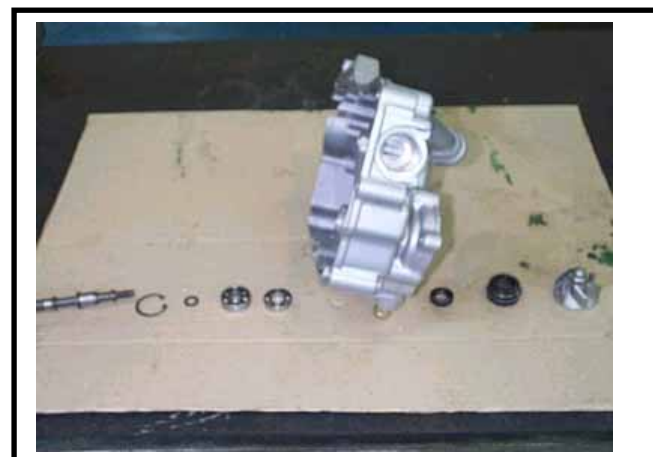
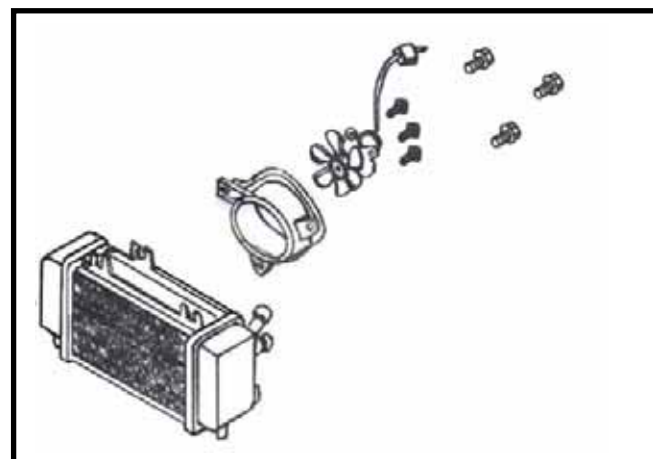
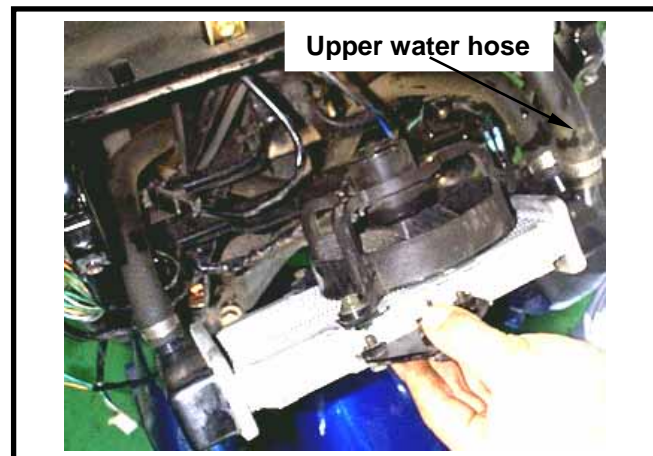
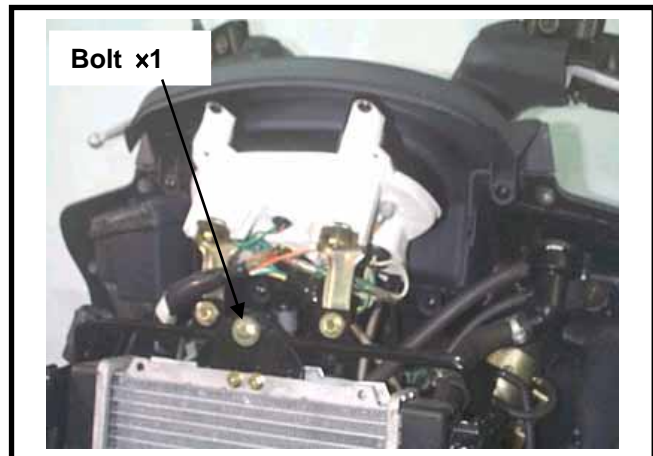

Removal of water pump

Remove the water hose.
Loosen three bolts and remove the pump cover.
Loosen 9 bolts and remove the right cover.
Take off the gasket and dowel pin.



Turn pump rotor clockwise and remove.

Caution

The rotor is provided with left turn thread.



Removal of Water Pump Shaft

Remove the circlip from the right crankcase cover.
Remove the water pump shaft and the inner bearing.
Remove the outside bearing by inner bearing puller.
Rotate the inner ring of bearing, the bearing shall move smoothly and quietly.
If the bearing does not rotate smoothly or produces a noise, replace it with new one.

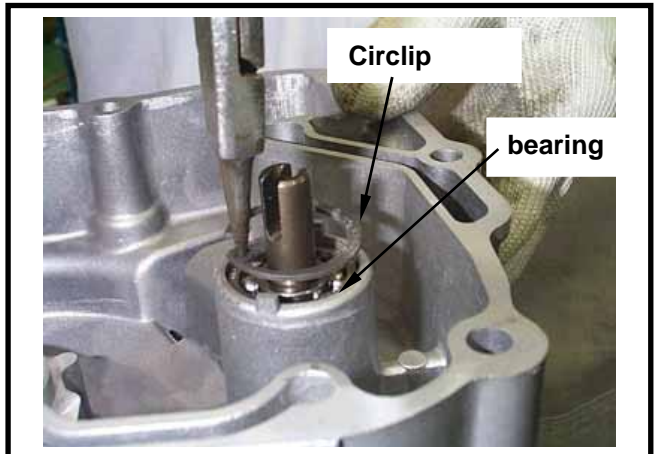

Check any wear and damage of the mechanical seal and inside seal .

Caution

The mechanical seal and inside seal must be replaced as a unit.



12. COOLING SYSTEM



Replacement of Mechanical Seal

Drive the mechanical seal and inner seal out of the right crankcase.

Tools required

Water pump bearing driver

Caution

Replace a new mechanical seal after removing it.



Install the new inner seal onto the right crankcase.

Tools required

Water pump mechanical seal driver



Apply a coat of sealant to the mating surfaces of the right crankcase before installing the new oil seal.

Install the mechanical seal onto the right crankcase.

Tools required

Water pump mechanical seal driver



Install a new outside bearing to the right crankcase cover.

Tool required

Water pump bearing (6901) driver

Caution

Do not reuse old bearing. It must be replaced with a new one once it has been removed.



Mount the water pump shaft and the inner bearing to the right crankcase cover.
Install the circlip to hold the inner bearing.

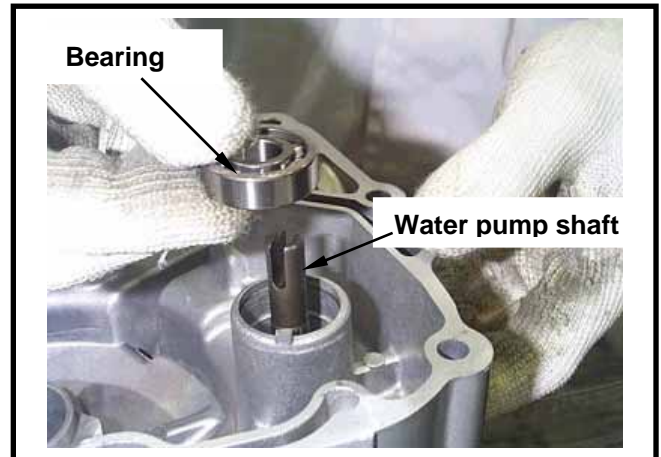

Install water pump rotor
Install the seal washer into the rotor.

⚠ Caution

Washer must be replaced together with the mechanical seal.



Install the rotor onto the water pump shaft and tighten.

Torque Value: 1.0~1.4 kgf-m

⚠ Caution

The rotor is left thread.

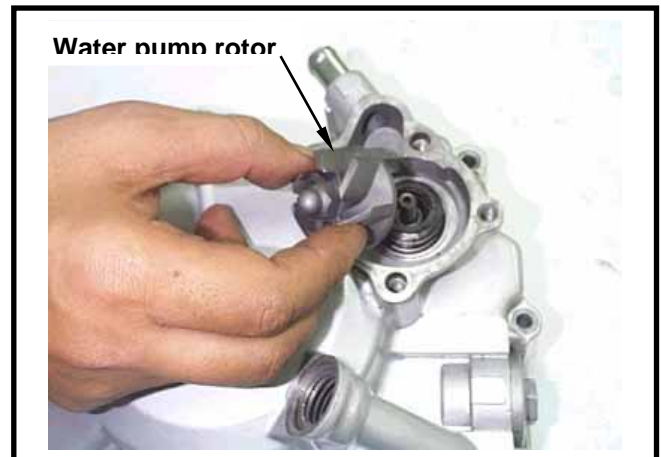

12. COOLING SYSTEM



Install the right crankcase cover.(bolt × 9)



Install the dowel pin and new gasket.
Install the water pump cover with three bolts.



Temperature sensor

Please refer to chapter 17 for inspection of temperature sensor.

Removal

Remove the body cover.
Drain out the coolant.
Disconnect the cable of temperature sensor.
Remove the temperature sensor.



Installation

Apply a coat of 3 Bond No. 1212 sealant or equivalent to the thread of temperature sensor and install it on the holder.
Connect the cable to the temperature sensor.
Refill the coolant and bleed out the air bubble (P12-4).
Install the right rear cover.



Thermostat

Removal

Remove the rear cover.
 Drain out the coolant.
 Disconnect the cable from the thermostat.
 Remove the water hose from the thermostat holder.
 Remove the air vent hose from the holder.
 Remove the holder and lock bolt from the cylinder head.
 Remove the temperature sensor and O ring from the holder.

Remove two bolts and separate the holder from the cover.

Remove the thermostat.

Inspection

Visually inspect thermostat for any damage.
 Place the thermostat into heated water to check its operation.

⚠ Caution

Whenever the thermostat and the thermometer are in contact to the wall of heated water container, the reading displayed is incorrect. If the valve of the thermostat remains open at room temperature or the valve operation is not corresponding to the temperature change, then it must be

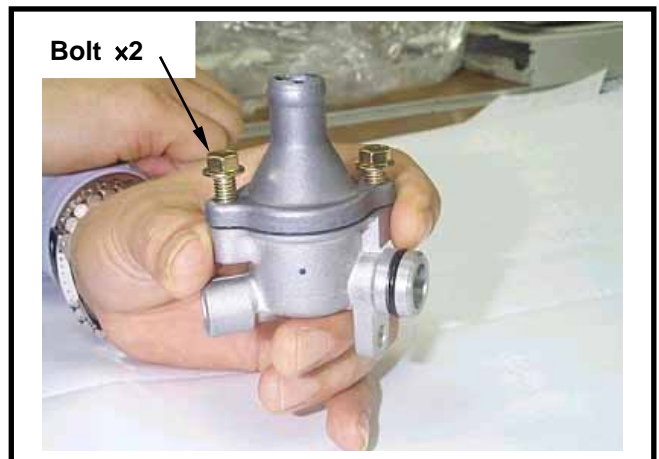
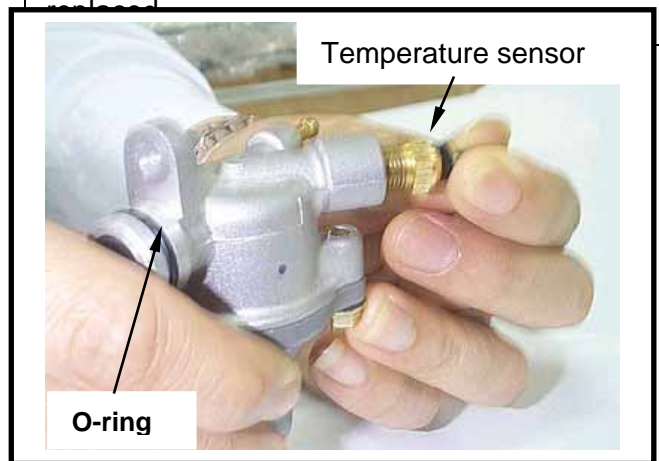

Technical Data

Valve begins to open	71 ~ 80°C
Valve stroke	3.5 ~ 4.5 mm at 80°C

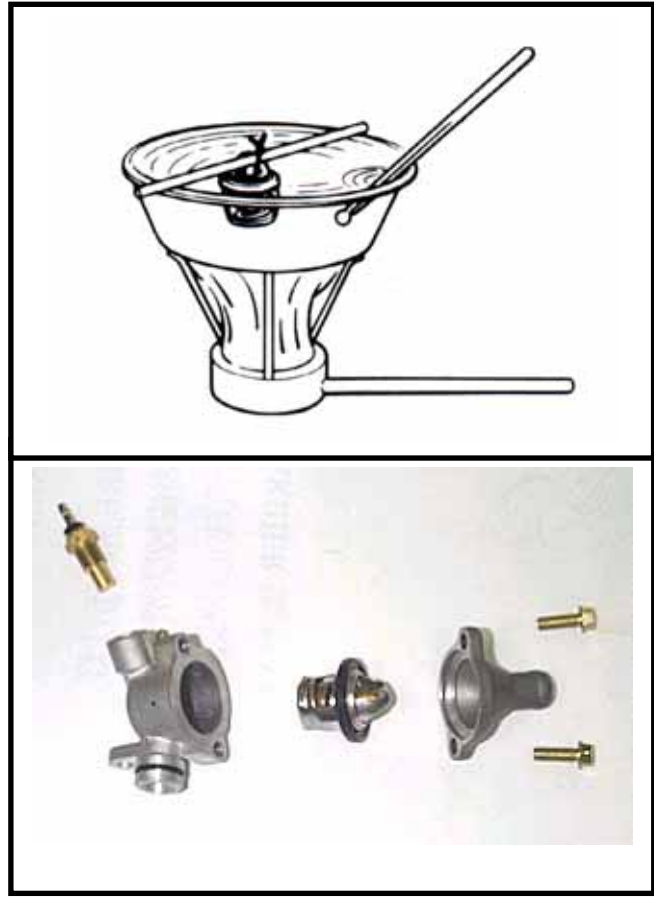

Installation

Install in reverse order of removal.

Caution

Always use a new oil ring and apply a coat of grease on it before installing.

Refill the specified coolant as necessary.

Mechanical Illustration	13-1	Side Cover	13-7
Maintenance	13-2	Body Cover	13-8
Steering Handlebar Guard.....	13-3	Central Cover	13-9
Front Guard	13-4	Foot Rest.....	13-10
Front Lower Spoiler	13-5	Inner Cover.....	13-11
Luggage Box	13-6	Front Fender	13-12

Body Overview

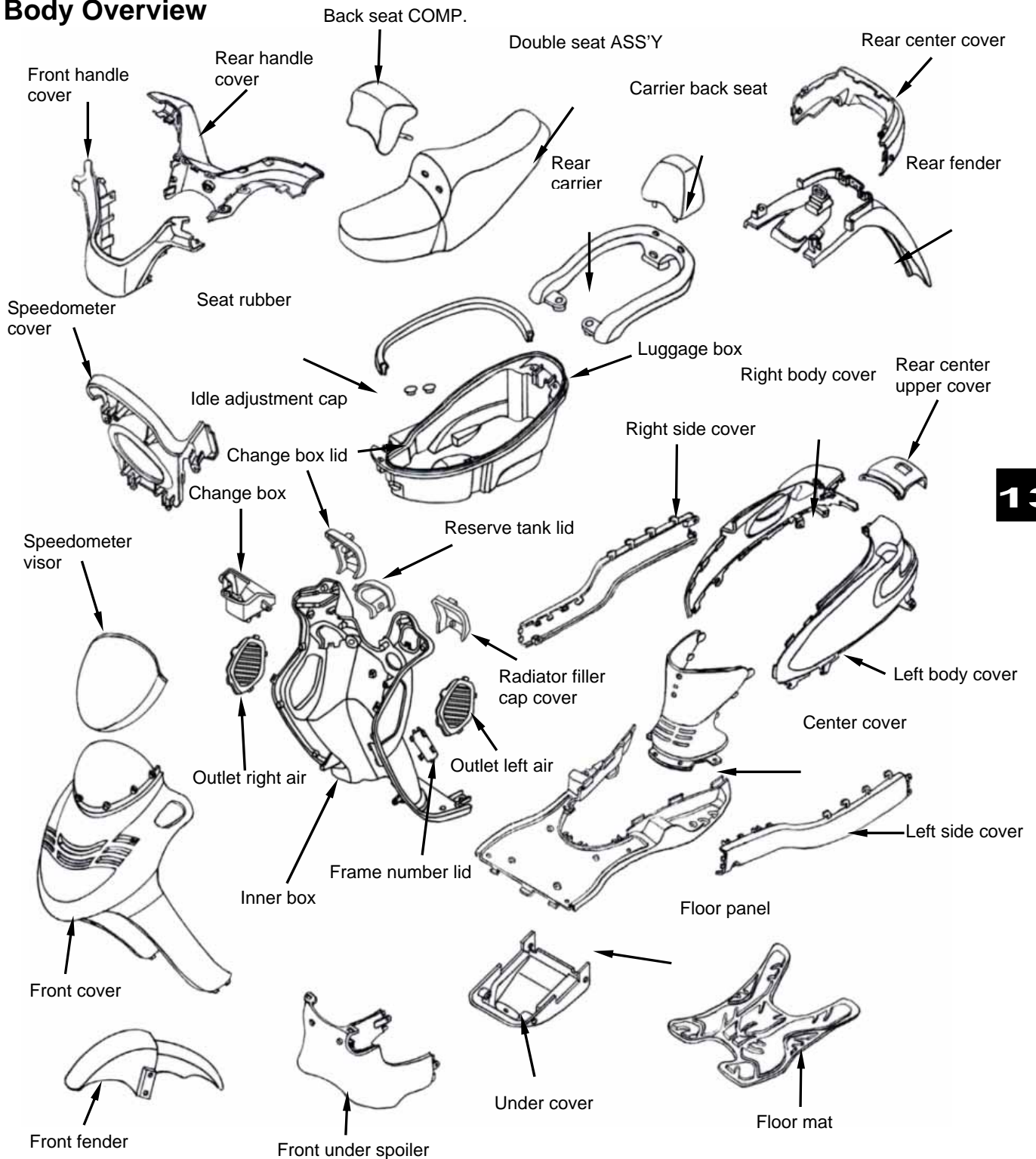

Maintenance

Body covers disassemble sequence:

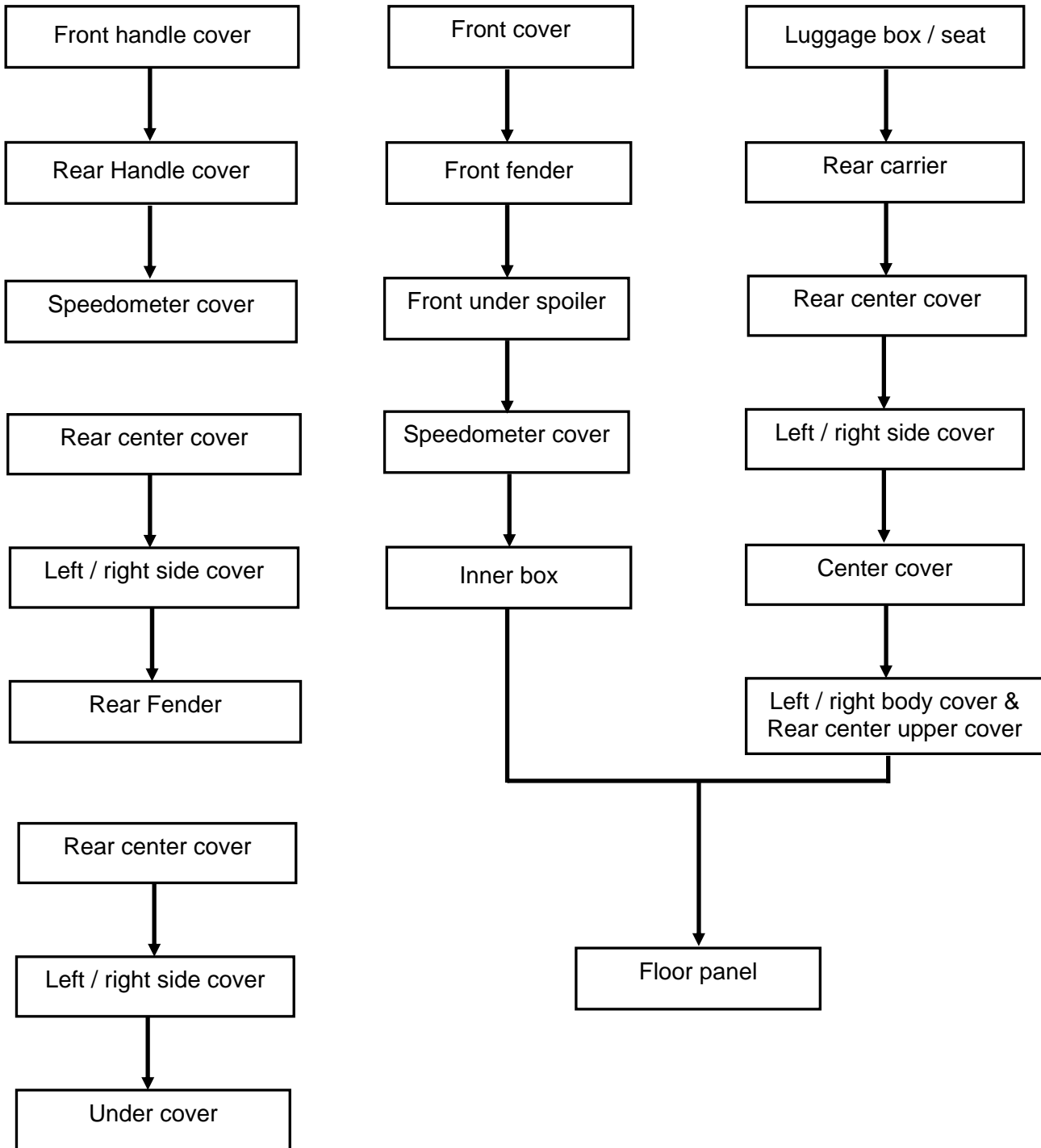

- Be careful not to damage various covers in assembly or disassembly operation.
- Never injure hooks molded on the body covers.
- Align the buckles on the guards with slot on the covers.
- Make sure that each hook is properly installed during the assembly.
- Never compact forcefully or hammer the guard and the covers during assembly.

Steering Handle Cover**Disassembly**

Loosen 5 screws from both sides and rear.



Disengage the buckle from the slot, take off the front cover of the handlebar and loosen two screws.

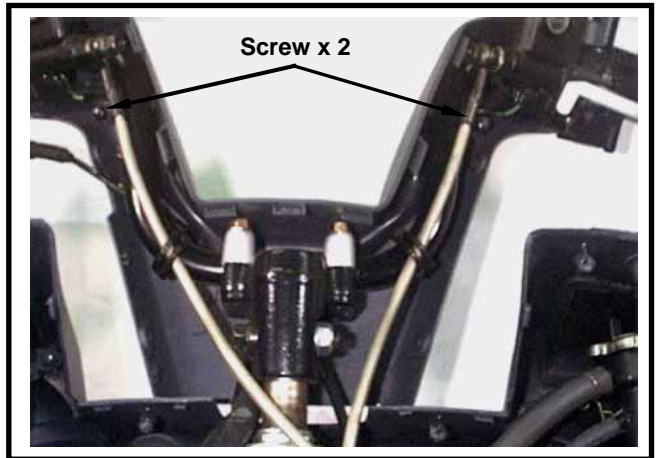

Dismount the rear cover of the handlebar.

**Assembly**

In reverse order of the disassembly.

⚠ Caution

The tail of each cover is held with buckles and slot, never pull them with force, or it would crack the buckles.

13. BODY COVERS



Front Cover

Disassembly

Loosen two lock bolts.



Loosen four screws on the lower part of the front cover.



Take off four screws that hold the front luggage carrier (Screw x 4).
Disconnect the connectors for the head lamp and the direction lamps.
Disassemble the front guard.



Assembly

In reverse order of the disassembly.

Front Under Spoiler**Disassembly**

Loosen six screws that hold the front inner box.



Loosen two screws that lock up the front under spoiler. (Screw x 2)



Loosen one screw at the back of the under spoiler. (Screw x 2)
Remove the front under spoiler.

**Assembly**

In reverse order of the disassembly.

13. BODY COVERS



Luggage Box

Disassembly

Lift up the seat saddle
Loosen six bolts inside the luggage box.
(Bolt x 6)

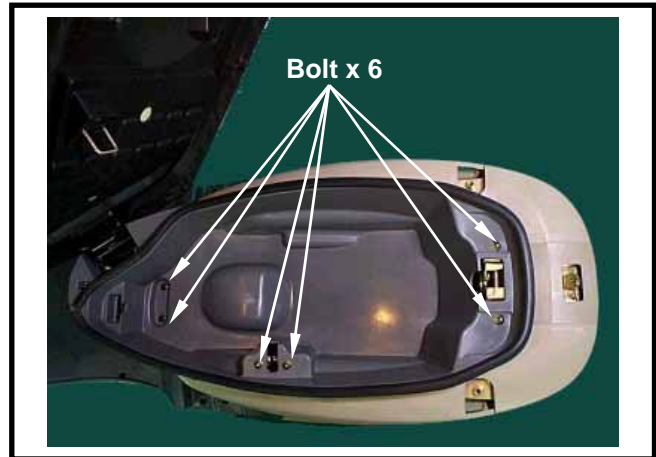

Loosen one hook screw on the center cover
(Screw x 1)

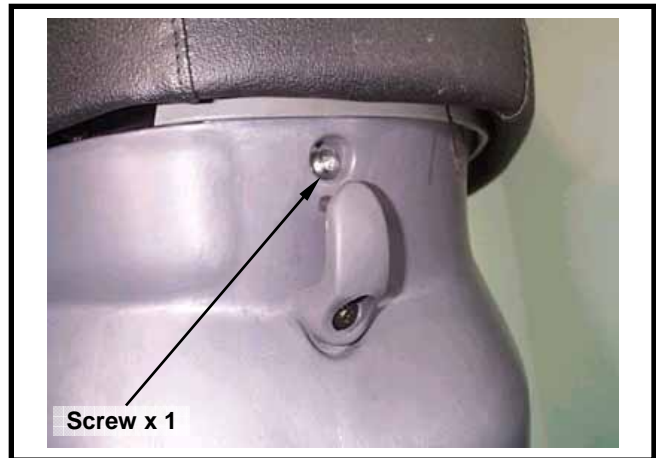

Hold the front end of the luggage box and lift it
upward to take off from the frame



Assembly

In reverse order of the disassembly.

Side Covers

Disassembly

Loosen four screws and take of the rear center cover.
(Screw x 4).



Loosen six screws and remove two side covers from the frame (Screw x 3 for each cover).

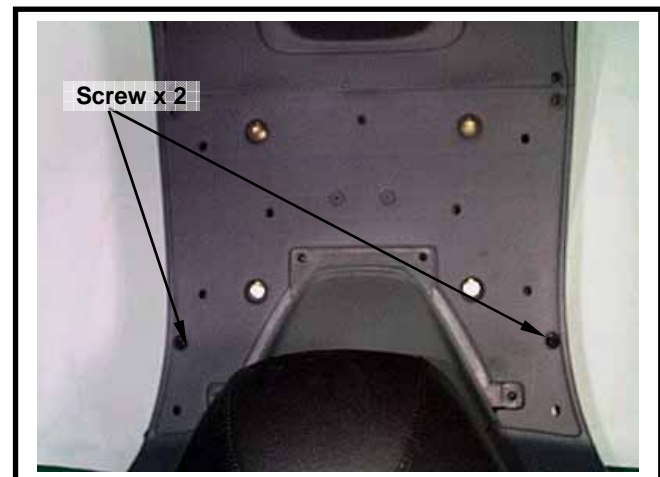

Assembly

In reverse order of the disassembly.

13. BODY COVERS



Body Cover

Disassembly

Loosen three bolts and remove the rear grip.
(Bolt x 3).

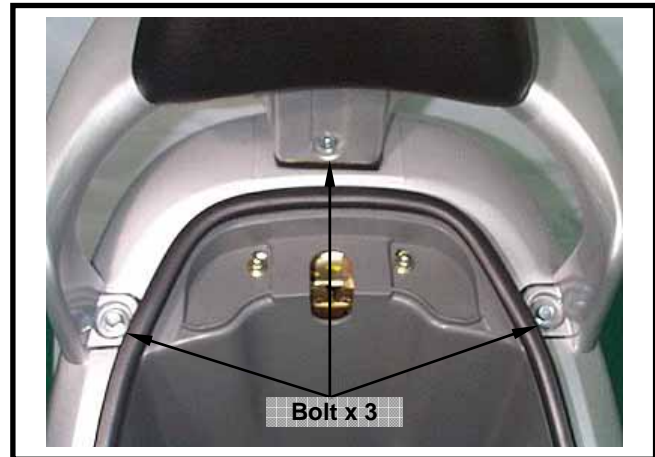

Loosen two bolts from the rear frame.
(Bolt x 2)



Loosen two screws that link the central guard and the body cover (Screw x 2).

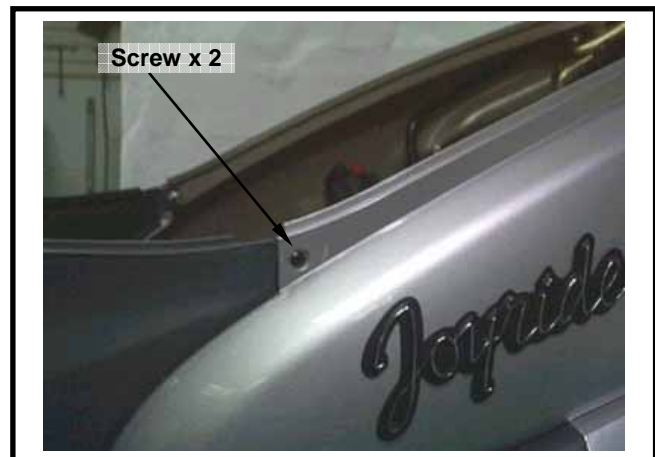

Loosen two bolts from the tail lamp (Bolt x 2).
Disconnect the tail lamp connector.
Hold the body cover with two hands, lift it upward
to take off from the frame.



Assembly

In reverse order of the disassembly described
above.

Center Cover**Disassembly**

Remove the hook and screw from the center cover (Screw x 1).

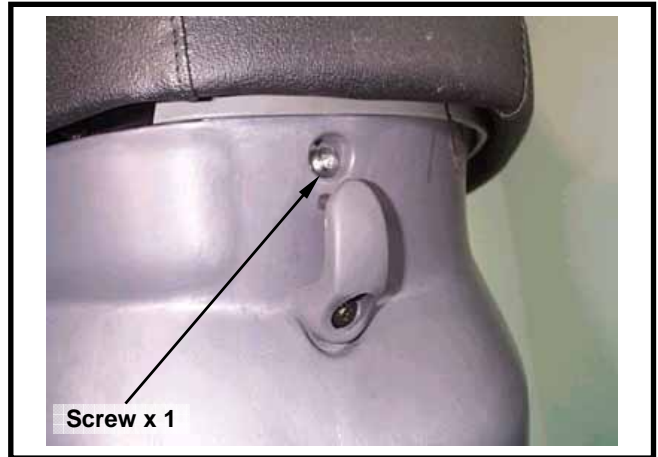

Loosen four screws and take off the center cover from the frame (Screw x 4).

**Assembly**

In reverse order of the disassembly as described above.

13. BODY COVERS



Floor Panel

Disassembly

Loosen four screws (Screw x 4).
Loosen four front bolts (Bolt x 4).

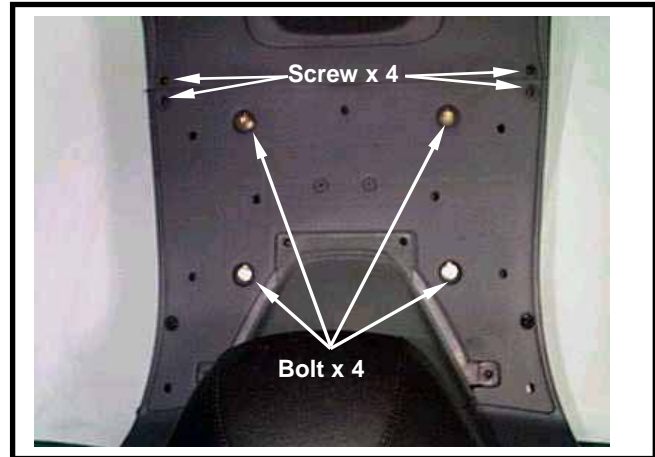

Loosen two bolts under the saddle (Bolt x 2).
Loosen four screws under the saddle (Screw x 4).

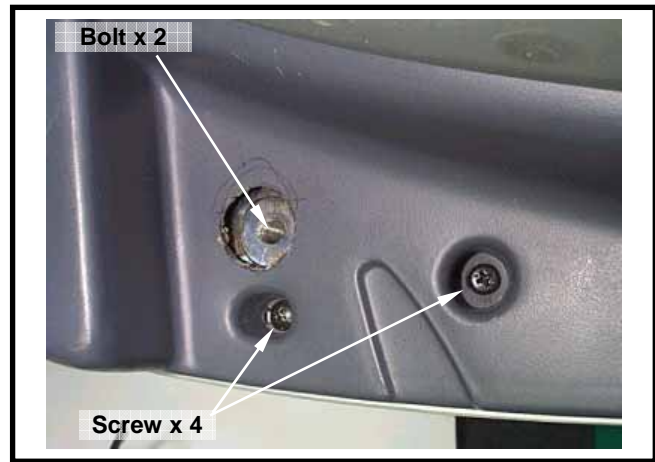

Remove the floor panel.



Assembly

In reverse order of the disassembly as described above.

Inner cover

Disassembly

Take off four screws from the speedometer cover (Screw x 4).
 Disconnect the cable and connector of the speedometer.
 Loosen two bolts from under speedometer (Screw x 2).
 Remove the speedometer and speedometer cover.

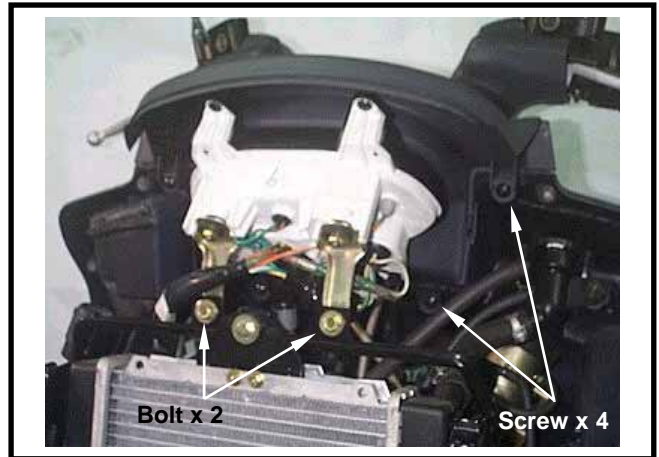

Loosen one bolt that holds the inlet cap of radiator (Bolt x 1).
 Loosen two bolts that hold the fuel filler (Screw x 2).

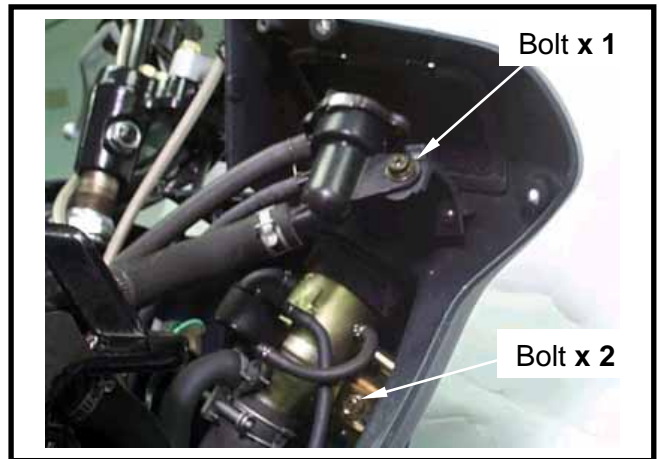

Remove the fuel filler cap and bushing.
 Disassemble the main switch cap.
 Loosen one screw at the rear of the inner box (Screw x 1).
 Remove the inner box.



Assembly

In reverse order of the disassembly as described above.

Caution

- While taking off the fuel filler cap, do not let it fall to the ground that may cause damage to the cap or personal injury.
- After the inner box is taken off, reinstall the fuel filler cap to prevent any foreign material from entering into the fuel tank.

13. BODY COVERS



Front Fender

Disassembly

Loosen four screws from the front fender (Screw x 4).

Lift the front fender upward and disengage the front shock absorber to remove the front fender.



Assembly

In reverse order of the disassembly as described above.

Rear Disk Brake System

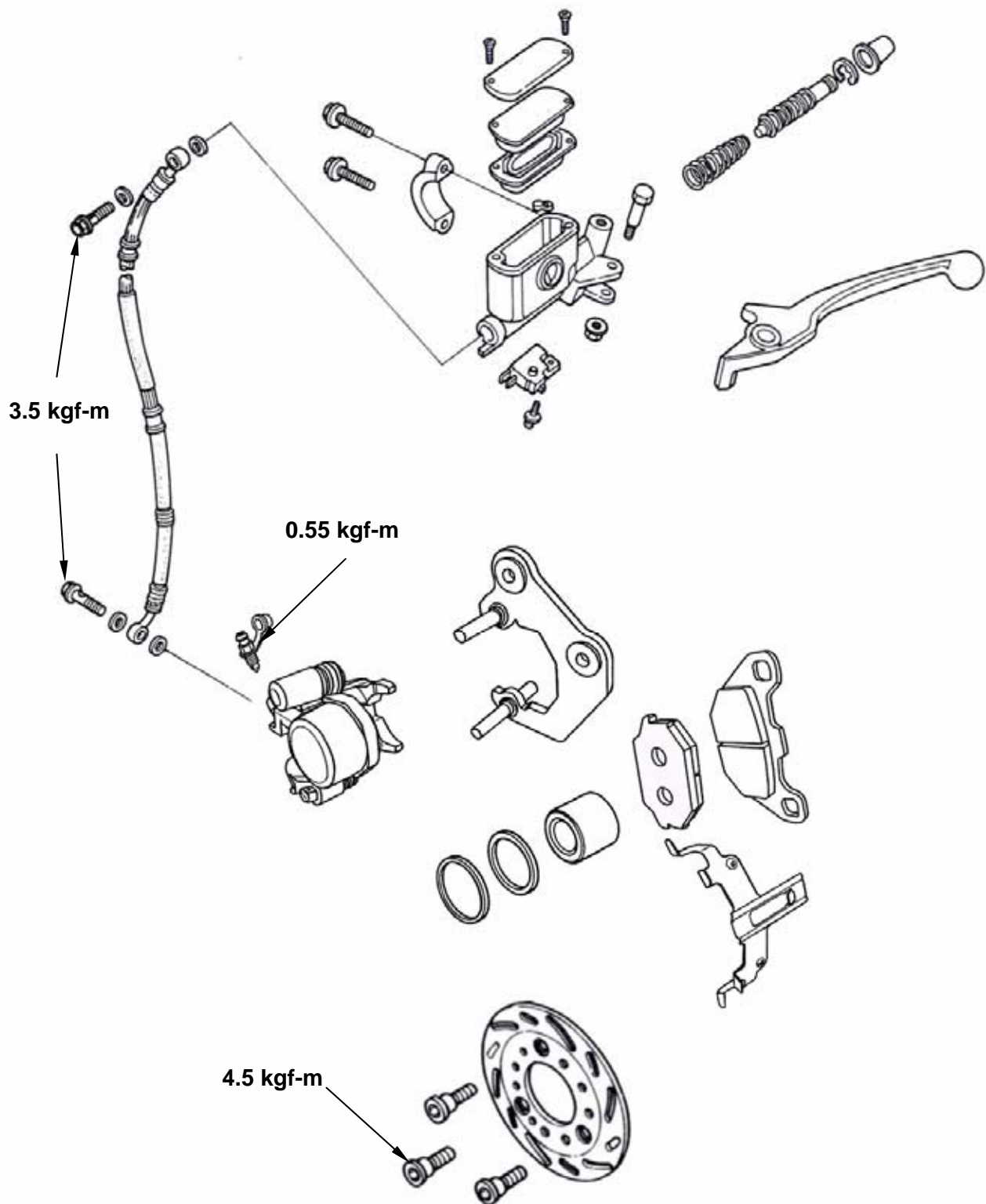

Maintenance Description

Operational precautions

Caution

Inhaling asbestos may cause disorders of respiration system or cancer, therefore, never use air hose or dry brush to clean brake parts. Use vacuum cleaner or other authorized tool instead.

- The brake calliper can be removed without removing the hydraulic system.
- After the hydraulic system is removed, or the brake system is felt to be too soft, bleed the hydraulic system.
- While refilling brake fluid, care should be taken not to let the foreign material entering into the brake system.
- Do not spill brake fluid on the painted surfaces, plastic or rubber parts to avoid damage.
- Check the operation of the brake system before riding.

Specifications

Item	Standard (mm)	Limit (mm)
The thickness of front and rear brake disc	4.000	2.500
Front and rear brake disc eccentricity	< 0.100	0.300
Master cylinder inner diameter	11.000 - 11.043	11.055
Master cylinder outer diameter	10.957 - 10.984	10.945
Diameter of front disc	273.000	-
Diameter of rear brake drum	200.000	-
Thickness of front brake lining	5.100	2.000
Thickness of rear brake lining	5.100	2.000

Torque values

Brake hose bolt	:	3.5 kg-m
Bolt for brake caliper	:	3.3 kg-m
Bolts for the lining guide pin	:	1.8 kg-m
Bolts for the lining guide pin cap	:	1.0 kg-m
Air-bleed valve	:	0.55 kg-m

Trouble Diagnosis

Soft brake lever

1. Air inside the hydraulic system
2. Hydraulic system leaking
3. Worn master piston
4. Worn brake pad
5. Poor brake caliper
6. Worn brake lining/disc
7. Low brake fluid
8. Blocked brake hose
9. Warp/bent brake disc
10. Bent brake lever

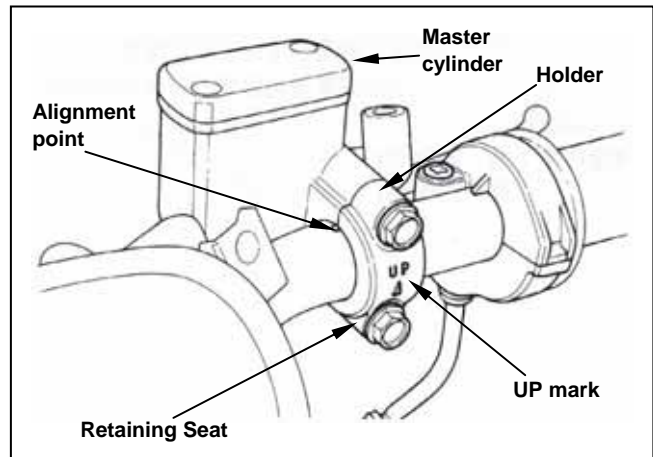

Hard operation of brake lever

1. Blocked brake system
2. Poor brake calliper
3. Blocked brake pipe
4. Seized/worn master cylinder piston
5. Bent brake lever

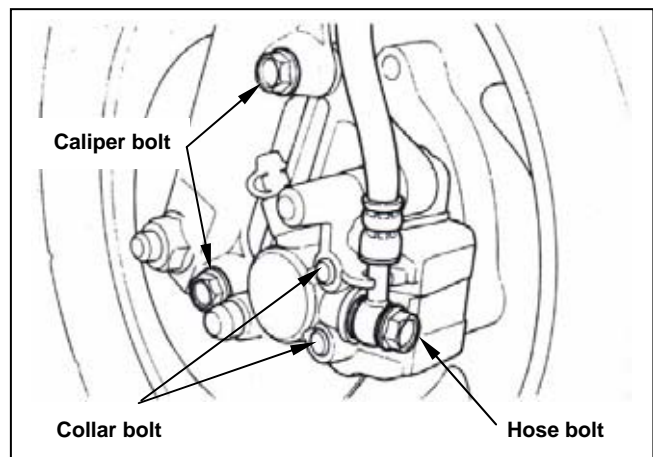

Uneven brake

1. Dirty brake lining/disc
2. Poor wheel alignment
3. Clogged brake hose
4. Deformed or warped brake disc
5. Restricted brake hose and fittings

Tight brake

1. Dirty brake lining/disc
2. Poor wheel alignment
3. Deformed or warped brake disc

Brake noise

1. Dirty lining
2. Deformed brake disc
3. Poor brake calliper installation
4. Imbalance brake disc or wheel

Hydraulic Disc Brake

- Close the drain valve of the hydraulic disc brake.
- Replace the brake fluid.

Before the brake fluid reservoir is removed, turn the handle so that the brake fluid reservoir becomes horizontal, then remove the brake fluid reservoir.

Cover the painted surfaces, plastic or rubber components with a rag when servicing brake system.

CAUTION

Spilled brake fluid on painted surfaces, plastic or rubber components may result in their damages.

Remove the master cylinder cap and diaphragm. Use high quality brake solvent to clean the dirty brake disc.

CAUTION

The dirty brake lining or disc will reduce the brake performance.

Refill up same brand brake fluid into the reservoir.

CAUTION

The mixed non-compatible brake fluid will reduce brake performance. Foreign materials will block the system causing brake performance to be reduced or totally lost.

Connect drain hose to drain valve.
Open the drain valve on the calliper and hold and release the brake lever alternatively until the old brake fluid is entirely drained out.
Close the drain valve and add specified brake fluid into the brake master cylinder.

Recommended brake fluid: WELLRUN DOT 3 brake fluid

CAUTION

To reuse the spent brake fluid will effect brake performance.

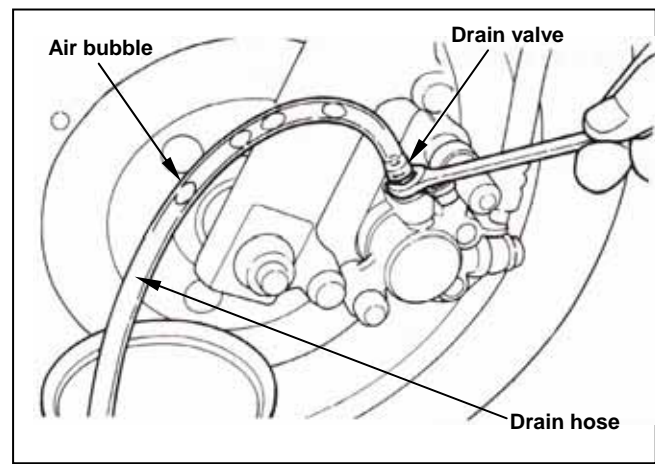
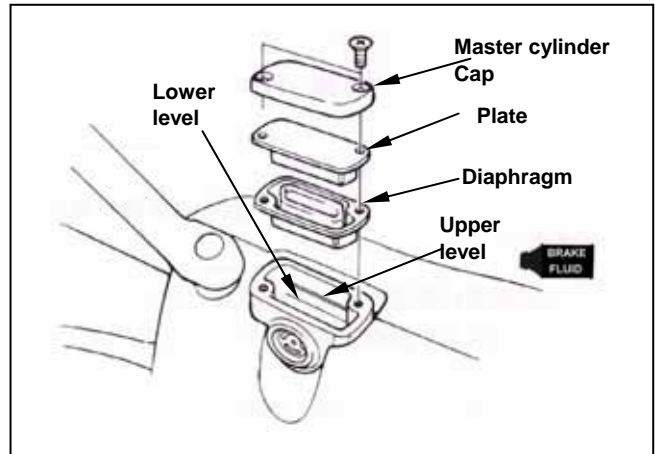

Connect one end of transparent hose to the drain valve, and put the other end into a container.

Open the drain valve around 1/4 turns, and at the same time hold the brake lever until there is no air bubble in the drain hose and also feeling resistance on the brake lever.

Close the drain valve when finishing the brake system refilling fluid procedure, and operate the brake lever to check whether air bubble is in brake system or not. If brake is still soft, please bleed the system as described below.

Air Bleed

1. Tightly hold the brake lever and open the drain valve around 1/4 turns, and then close the valve.

⚠ CAUTION

- Do not release the brake lever before the drain valve is closed.
- Always check the brake fluid level when carrying out the air bleeding procedure to avoid air enter into the system.

2. Slowly release the brake lever, and wait for a few seconds until it reaches its top position.
3. Repeat the steps 1 and 2 until there is no air bubble at the end of the hose.
4. Tightly close the drain valve.
5. Make sure the brake fluid is in the UPPER level of the master cylinder, and refill the fluid if necessary.
6. Cover the cap.

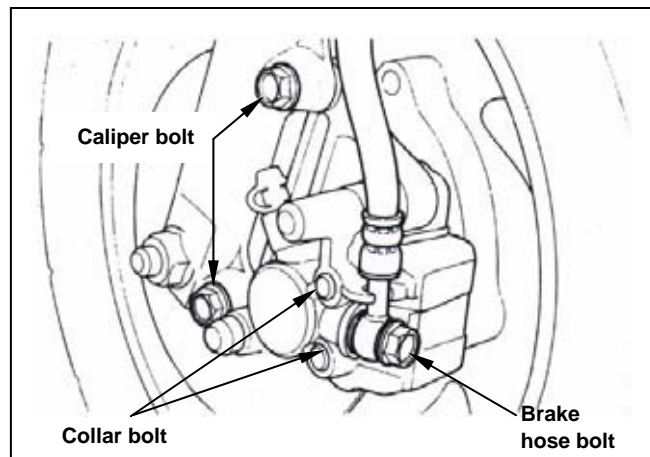
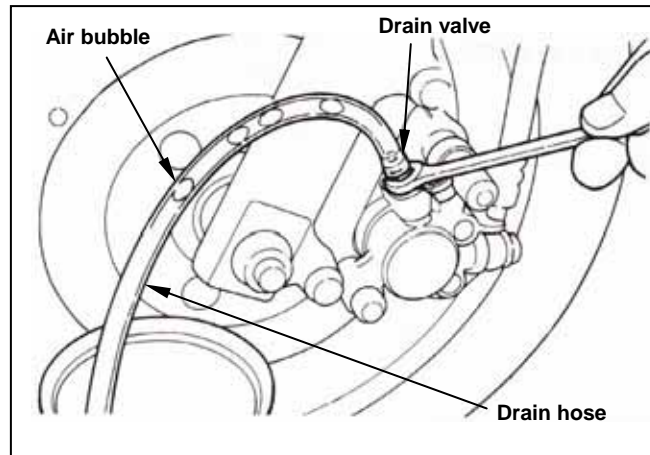

Brake Calliper Removal

Place a container under the brake caliper, and loosen the brake hose bolt and finally remove the brake hoses.

⚠ CAUTION

Do not spill brake fluid on painted surfaces.

Remove the bolt cap and loosen the lining guide bolts.
Remove two calliper bolts and the calliper.

Brake Calliper Installation

Install the brake calliper and tighten the attaching bolts securely.

Torque: 3.3 kg-m

⚠ CAUTION

- Use M8 x 35 mm flange bolt only.
- Long bolt will impair the operation of brake disc.

Tighten the lining guide bolt.

Torque: 1.8 kg-m

Install bolt cap.

Torque: 1.0 kg-m

Use two seal washers and hose bolts to lock the hose and brake calliper in place.

Torque: 3.5 kg-m

Refill up the brake fluid to the reservoir and make necessary air bleeding.

Brake Disc Inspection

Visually check the brake disc for wear or break.

Measure the thickness of the disc at several places. Replace the disc if it has exceeded the service limit.

Allowable limit: 2.0 mm

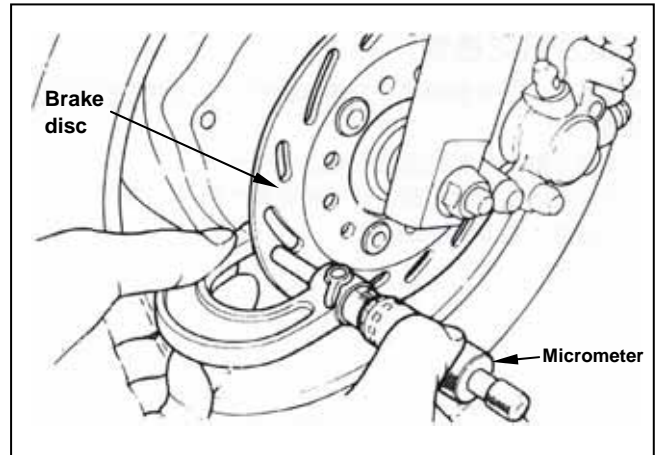

Remove the brake disc from wheel.

Check the disc for deformation and bend.

Allowable limit: 0.30 mm

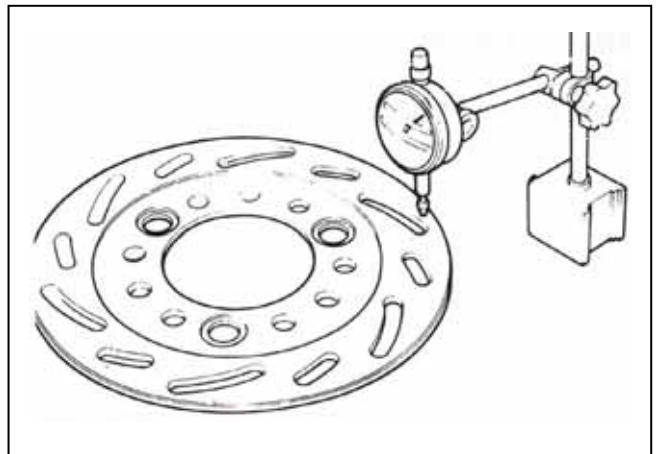

Brake Master Cylinder Removal

⚠ CAUTION

Do not let foreign materials enter into the cylinder.

⚠ CAUTION

When replacement, the whole set of master cylinder, piston, spring, diaphragm and circlip should be replaced in a set.

Remove the front and rear handlebar guards.

Remove the wires of brake lamp switch.

Drain out the brake fluid.

Remove the brake lever from the brake master cylinder.

Remove the brake hose.

Remove the master cylinder seat and the master cylinder.

Remove the rubber pad.

Remove the circlip.

Remove the piston and the spring.

Clean the master cylinder with recommended brake fluid.

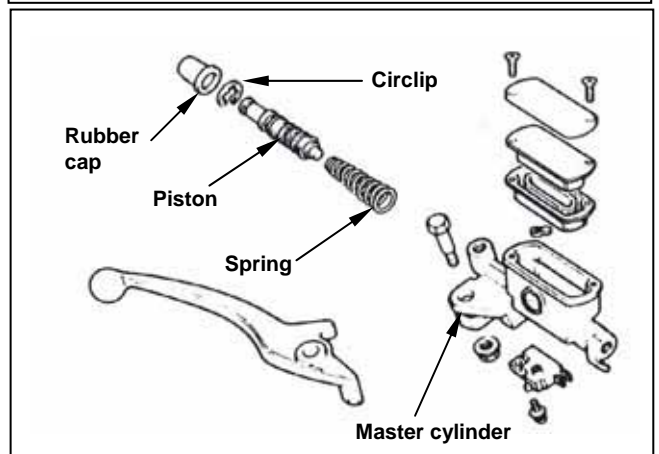
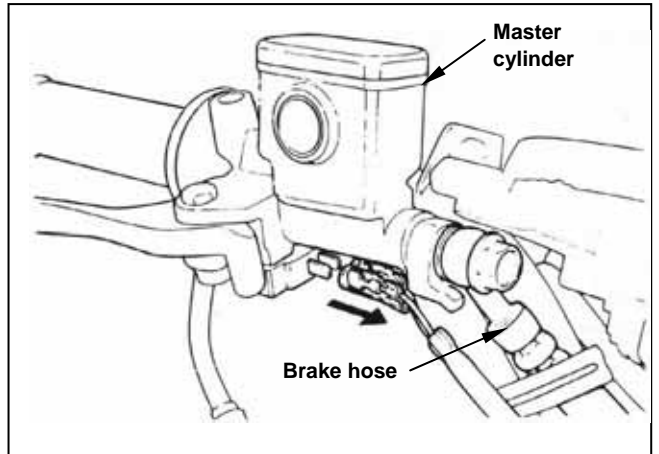

Master Cylinder Inspection

Check the master cylinder for damage or scratch. Replace it if necessary. Measure the cylinder inner diameter at several points along both X and Y directions. Replace the cylinder if the measured values exceed allowable limit.

Allowable limit: 11.055 mm

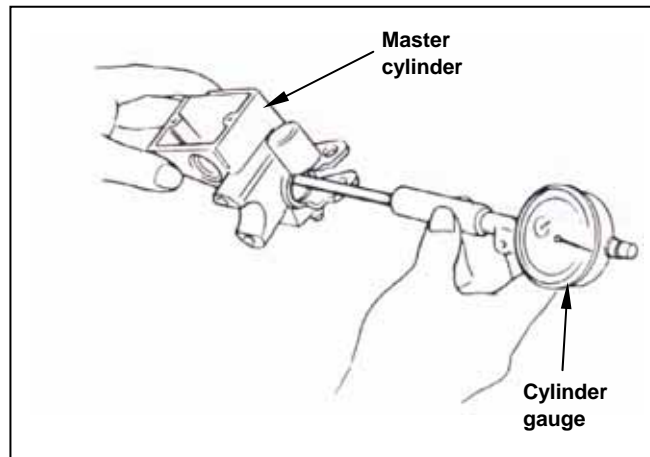

Measure the outer diameter of the piston. Replace the piston if its measured value exceeds allowable limit.

Allowable limit: 10.945 mm

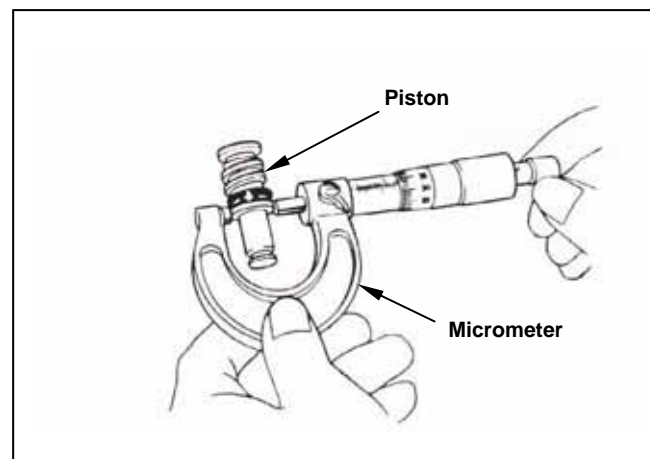

Master Cylinder Assembly

⚠ CAUTION

- It is necessary to replace the whole set comprising piston, spring, piston cup, and circlip.
- Make sure there is no dust on all components before assembling.

Apply clean brake fluid to the piston cup, and then install the cup onto the piston. Install the larger end of the spring onto the master cylinder. Note the direction of the piston when installing.

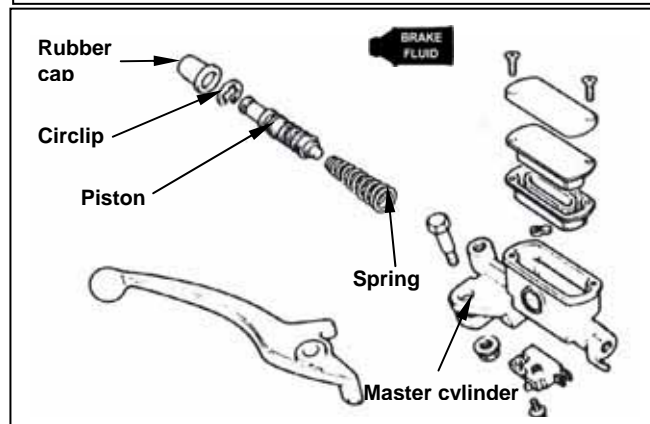

⚠ CAUTION

- Never install the piston in the opposite direction. (Refer to the diagram.)
- Make sure the circlip is seated securely in the groove.

Install the rubber cap into the groove correctly. Place the master cylinder onto handlebar, and install the master cylinder seat and its bolts. The "UP" mark on the seat should face upward. Align the master cylinder seat with the alignment point on the handlebar. Tighten the upper bolt of the seat to specified torque value, and then tighten lower bolt to the same specified torque value. Install the brake lever, and connect wires to brake lamp switch. Connect brake hoses with 2 new washes. Tighten the brake hose bolt to the specified torque value. Make sure the hose is installed correctly. Install all wires, hoses, and components carefully so avoid to twisting them together.

⚠ CAUTION

Improper routing may damage leads, hoses or pipes.

⚠ CAUTION

Kink of brake leads, hose or pipe may reduce brake performance.

Add specified brake fluid and bleed air from the system.

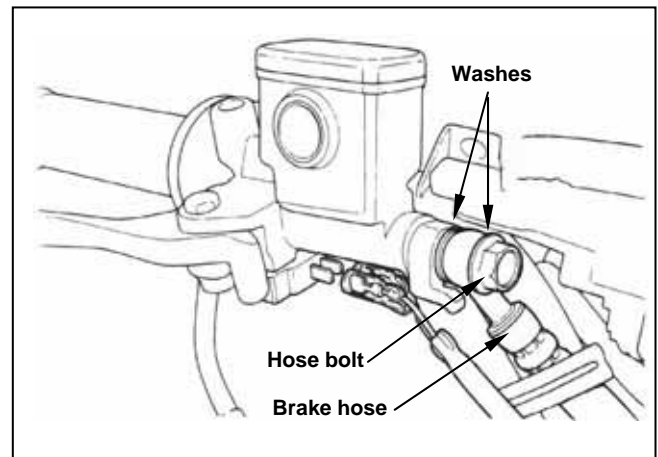
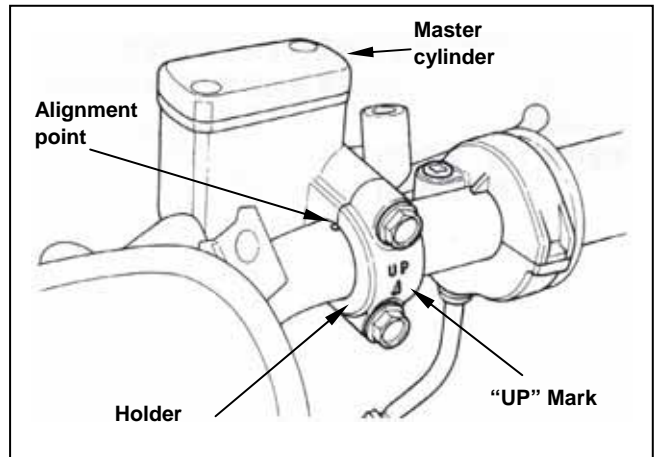

Notes

Mechanical Illustration	15-1	Front Wheel.....	15-6
Operational Precautions.....	15-2	Front Brake	15-9
Trouble Diagnosis.....	15-2	Front Shock Absorber.....	15-10
Steering Handlebar	15-3	Front Fork/Steering	15-11

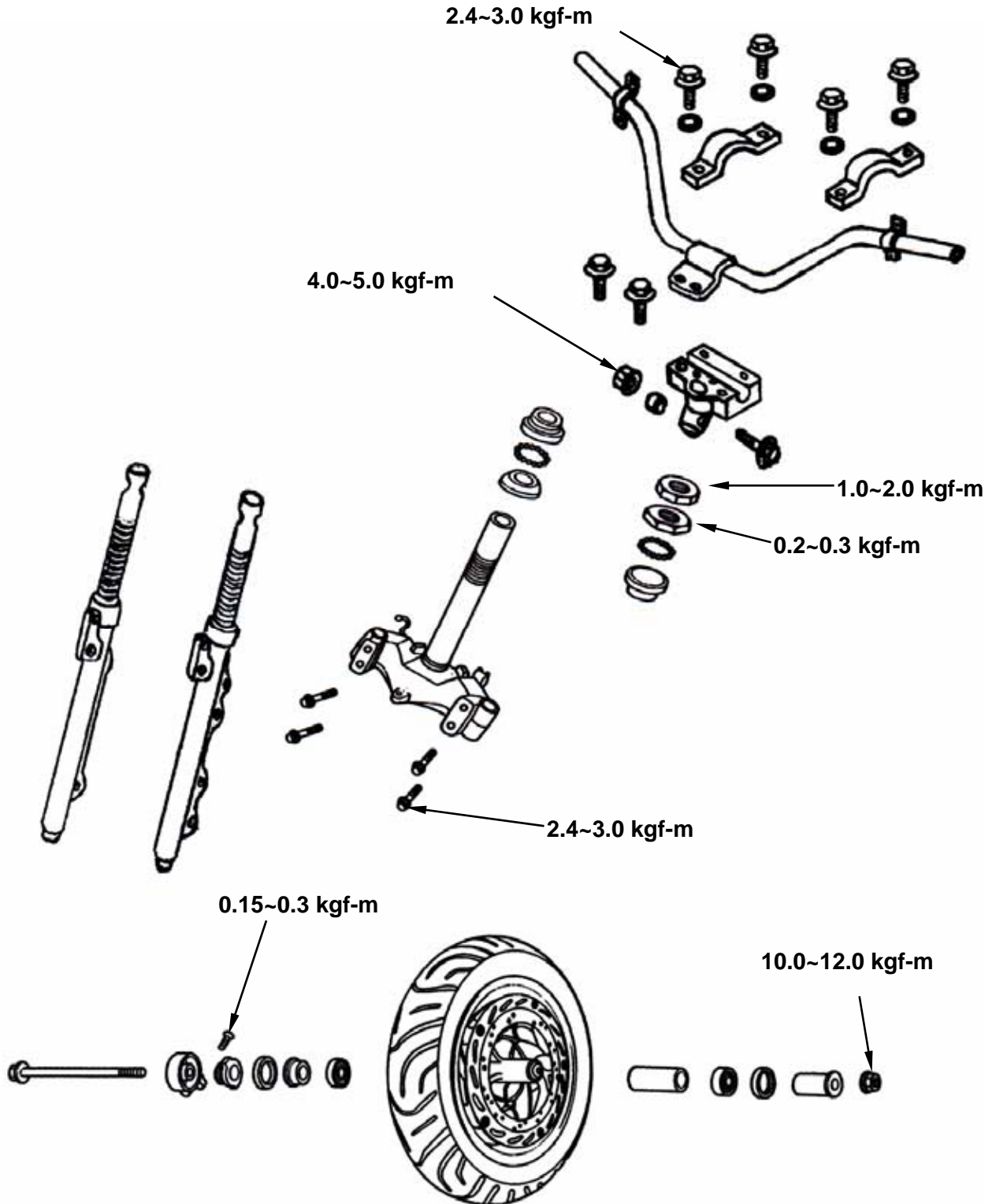

Operational Precautions

General

Please refer to the Maintenance Manual of tubeless tire in respect to the removal, repair and installation of the tire.

Torque Values

Nut for the front wheel axle	10.0 ~ 12.0 kgf-m
Nut for the steering shaft	4.0 ~ 5.0 kgf-m
Lock nut for the steering shaft	1.0 ~ 2.0 kgf-m
Top crown for the steering shaft	0.2 ~ 0.3 kgf-m
Locating screw for the speedometer cable	0.15 ~0.3 kgf-m
Front shock absorber: Upper lock bolt	2.4 ~ 3.0 kgf-m

Tools

Special Tools

Inner bearing puller
Steering nut wrench
Driver 32*35mm
Driver 42*47mm

Trouble Diagnosis

Hard to steer

- The steering shaft bolt is too tight.
- The ball and the top crown of the steering shaft are damaged.
- Insufficient tire pressure.

The steering handlebar is tilted

- Uneven arrangement of the front shock absorbers.
- The front fork is bent.
- The front wheel axle is bent.

The front wheel run out

- The rim is bent.
- The wheel axle nut is not tightened enough.
- Side-worn or poor tire.
- The bearing clearance of the wheel axle is too large.

Soft shock absorber

- The front fork spring is worn out.
- The oil seal of the front shock absorber is leaking.

Noise in front shock absorber

- The connecting rod of the shock absorber is warped.
- The joint of the shock absorber gets loose.

Steering Handlebar

Removal

Remove the front handle cover. (Screw x4)

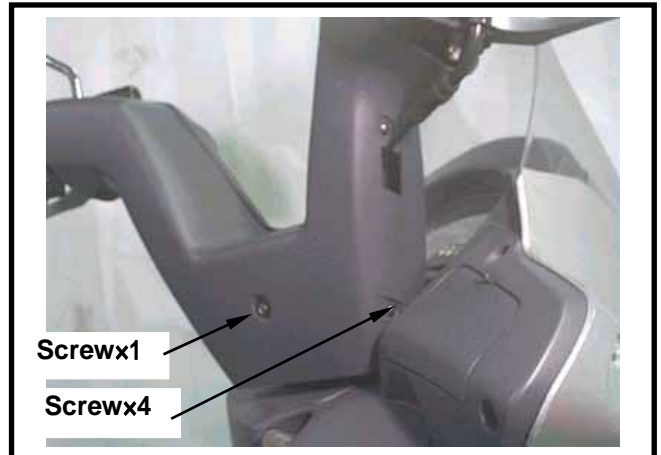

Remove the rear handle cover. (Screw x3)



Remove the right switch assembly by loosening two screws.
Remove the acceleration cable and take off the handlebar.

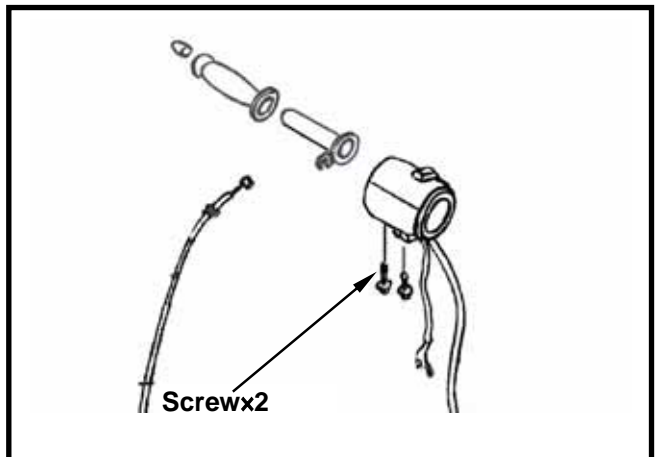

Loosen the lock bolt for the master cylinder of the front brake.

Remove the master cylinder of the front brake.

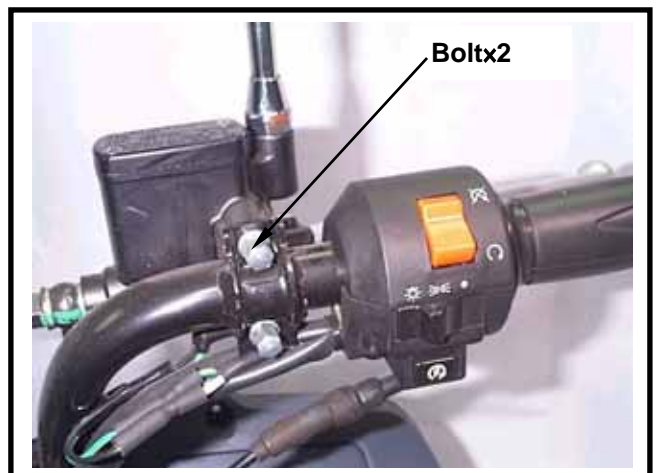

15. STEERING/FRONT WHEEL/FRONT BRAKE/FRONT CUSHION

Remove the left switch assembly by loosening two screws.

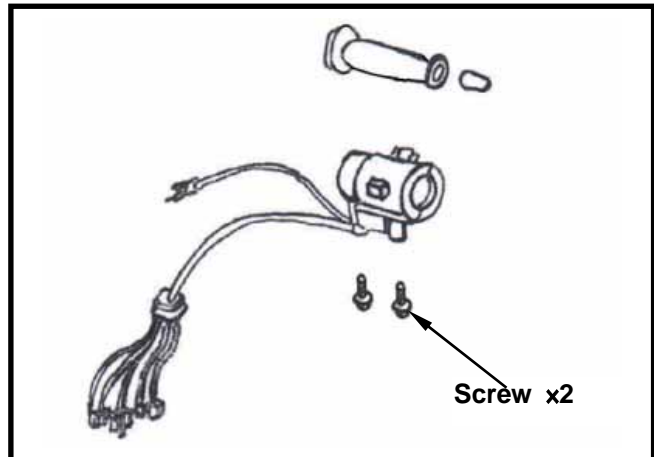

Loosen the lock bolt for the master cylinder of the rear brake.

Remove the master cylinder of the rear brake.

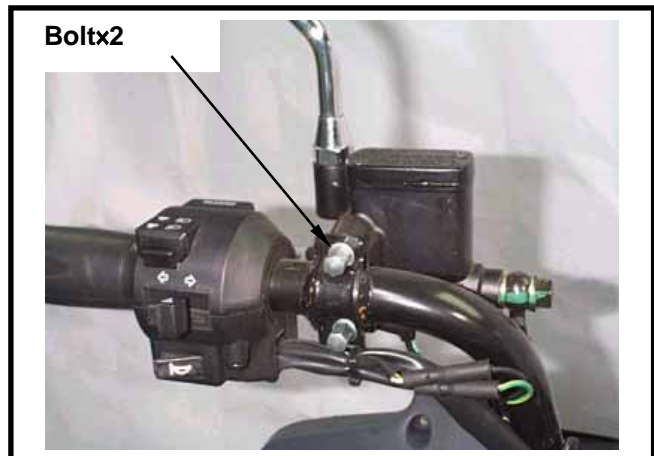

Loosen the lock bolt for the handle fix bolts.
(Bolt x4)



Loosen the lock bolts for the handle holder of the handlebar. (Bolt x4)

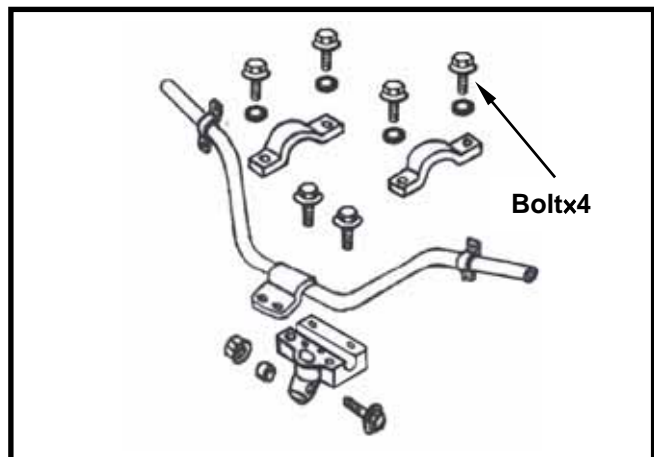

Loosen nuts and locating sleeve from the handlebar.
Remove the handlebar.



Installation

In reverse order of the disassembly.

⚠ Caution

Apply grease to the throttle cable end and connect it to the throttle holder.
After the steering handlebar is installed, check the throttle cable for free movement.

Carry out the following inspection and adjustment:

- Operation of the throttle.
- Brake level free travel.
- Operation of all meters.

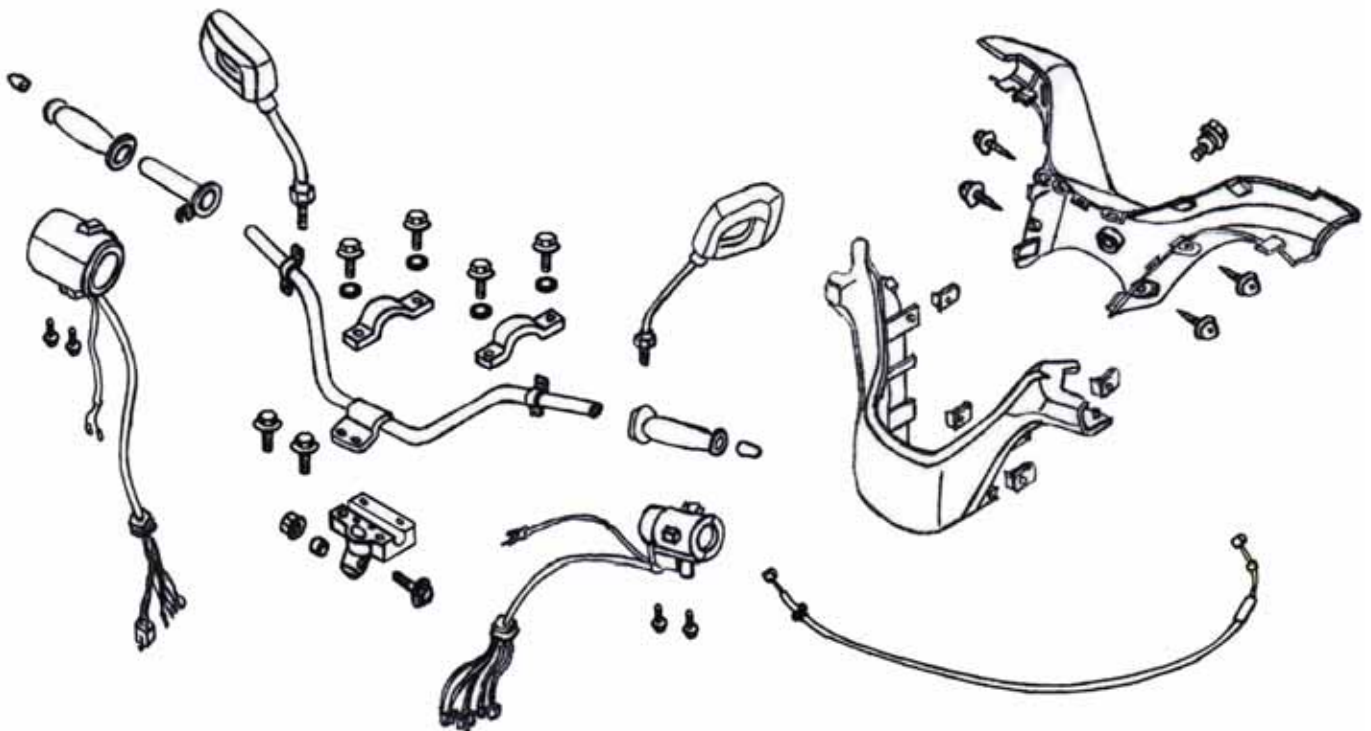

Front Wheel

Removal

Loosen two screws from the front brake calliper.
Remove the front brake calliper.

⚠ Caution

Care shall be taken not to push the brake lever to avoid the brake pad being squeezed out. In case that the brake pad is accidentally squeezed out, use a screwdriver to force it back to the place.

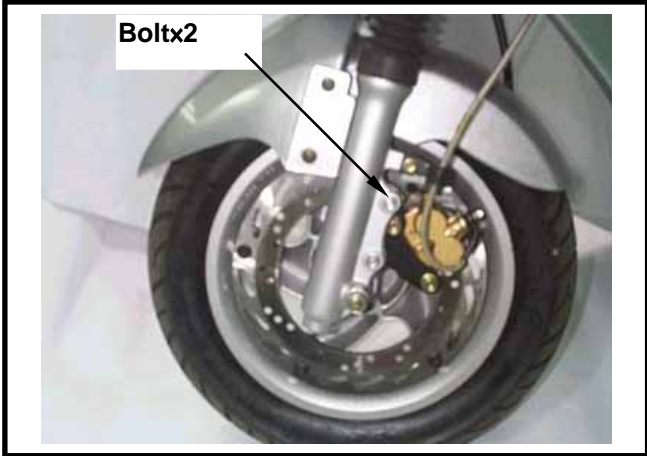

Remove the speedometer cable.
Turn loose the nuts and pull out the wheel axle.
Remove the front wheel.

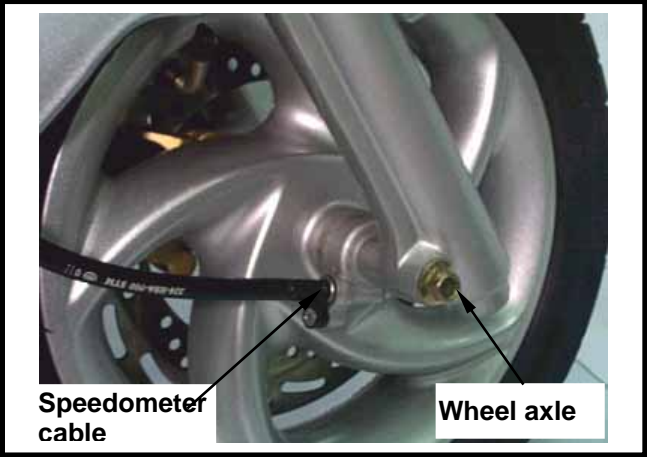

Inspection

Wheel axle

Place the wheel axle on a V block, measure its runout.

Service limit: 0.2 mm

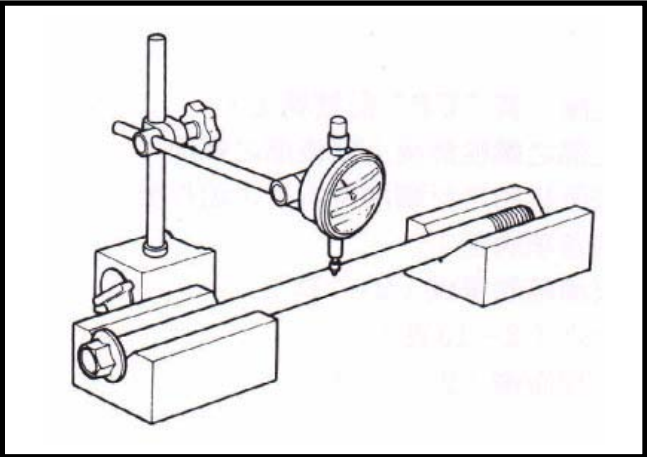

Wheel axle

Use finger to move the inner ring of each bearing, it shall move smoothly and quietly. Check the outer ring is securely attached on the wheel hub. If the motion of the inner ring of the bearing is not smooth, or noisy and loose when being moved, remove and discard it.

⚠ Caution

The bearing shall be replaced in pair.

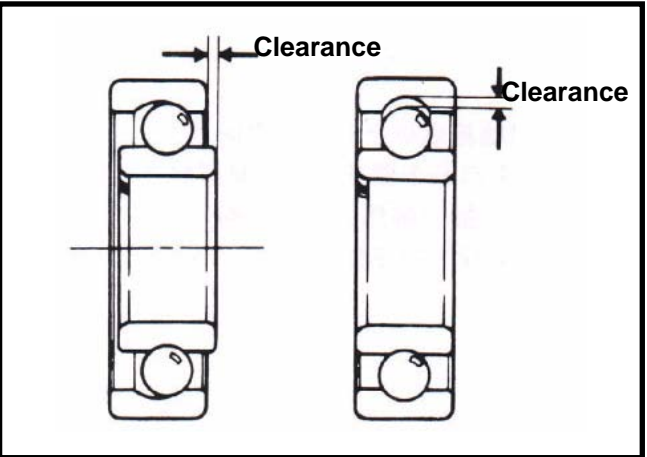

Wheel rim

Place the wheel rim on a rotary rack.
Rotate the wheel rim and measure the runout.

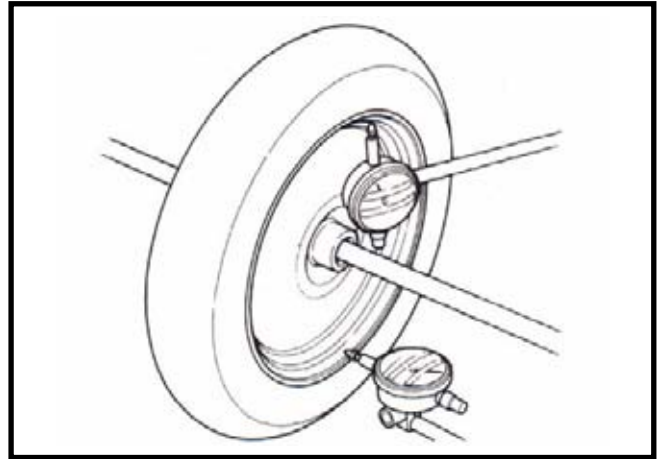

Service limit:

Radial: 2.0 mm

Axial: 2.0 mm

Disassembly

Remove the bushes and dust-proofing oil seal.

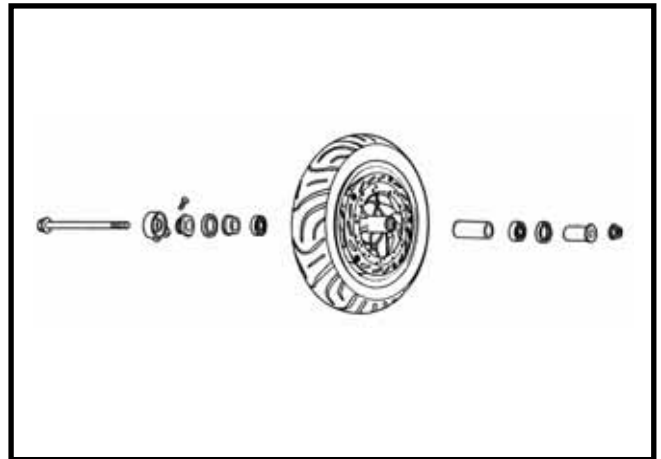

Insert the bearing puller into the bearing and pull out the bearing.
Remove the spacer and take off the bearing itself.

Tools

Bearing puller (Inner)

Assembly

Fill the bearing cap with grease
Place the left bearing into the bracket.
Install the spacer and place the right bearing into the bracket.

⚠ Caution

Never incline the bearing when it is installed.

⚠ Caution

Never use the old bearing. It must be replaced with a new one once it was removed.

Tools

Hydraulic presser

15. STEERING/FRONT WHEEL/FRONT BRAKE/FRONT CUSHION

Assembly

Assemble in reverse order of disassembly.



Apply a coat of grease on the inner side of the dust-proofing oil seal.
Install the dust proofing oil seal and the left and right bushes.

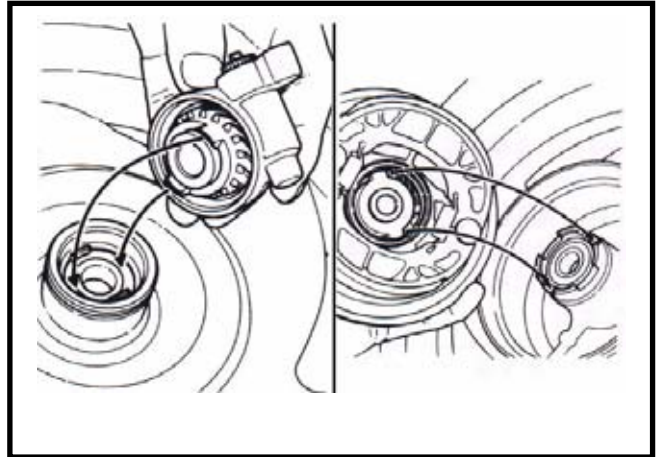

Installation

Insert the wheel axle through the front shock absorber and wheel.



Tighten the nut for the wheel axle.
Torque value: 10.0 ~ 12.0 kgf-m



Install the speedometer cable.



Press the brake pad to open.
Install the brake caliper and tighten the lock screw.

Torque value: 3.3 kgf-m



Front Brake

Remove the front wheel.
Loosen the lock screws and remove the brake disk.

Inspection

Check the brake disk for smoothness, damage and deformation. Measure the thickness of the disk.

Allowable minimum thickness: 2.5 mm

Even the disk has an even wear, but the disk shall not be less than the allowable minimum thickness.

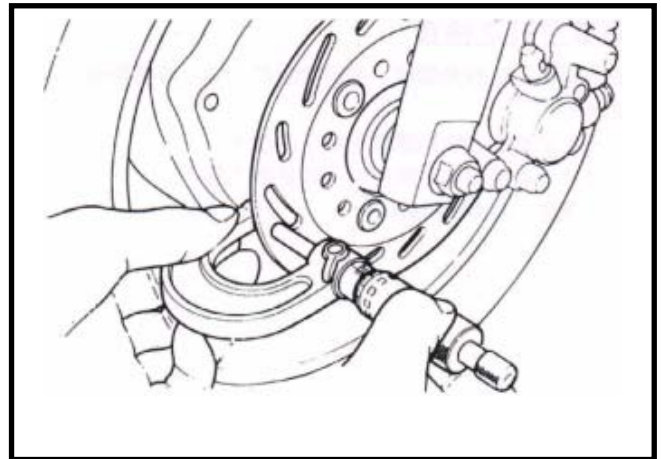

Warning

- Never contaminate the brake disk with grease. The contaminated brake disk will reduce its performance.
- Preferably, the operator shall wear a respirator and gloves, and use a vacuum cleaner to clean the brake.

Front Shock Absorber

Removal of front shock absorber

Loosen two bolts from the front brake calliper.
Remove the front brake calliper and hose.

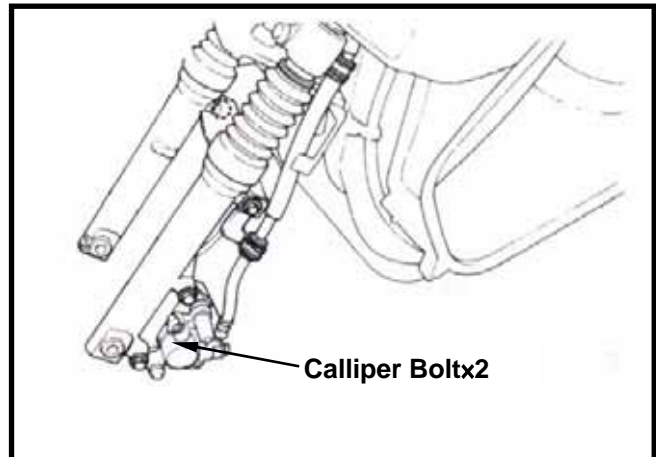

Loosen the bolts and remove the front shock absorber.

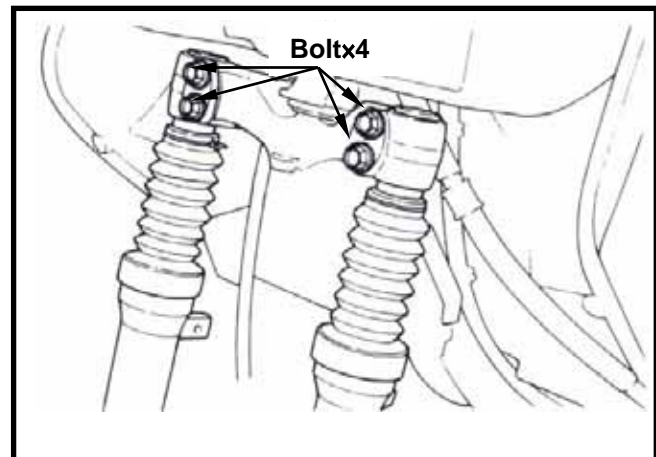

Installation

Install the front fork and front shock absorber.
Tighten the bolts.
Align the top of the cushion with the steering and
tighten the bolt. (Note not to interference the
cushion oil installing bolt.)

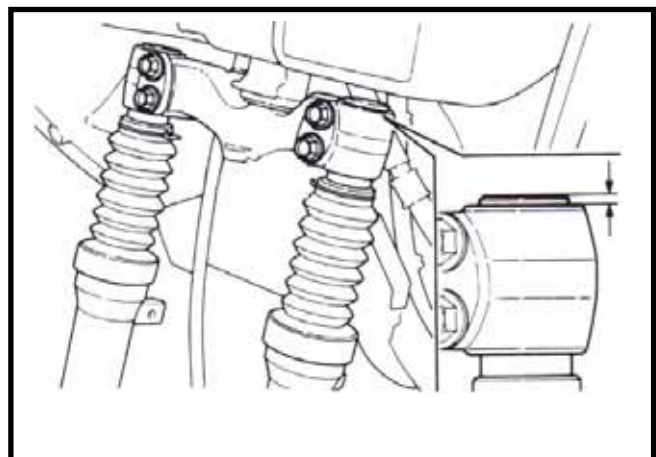

Front Fork/Steering

Removal of the front fork

Remove the following parts:

- The instrument panel assembly
- The Steering handlebar
- The front wheel

Use the steering nut wrench to loosen the lock nut from the steering.

Tools

Steering head top thread wrench

Remove the top crown and front fork.

Caution

Place balls in a container to avoid missing.

Check the top crown to see any wear and damage. If affirmative, replace it.

Replace the lower bearing for the top crown

Use the proper tool to remove the lower bearing and discard it.

Install a new top crown bearing to the steering shaft.

Place the new bearing on the old bearing, use driver to drive the new bearing into the bearing carrier.

Inspection of bearing carrier

Check the upper and lower bearing carriers to see any wear and damage.

If found, replace them.

Replacement of ball race

Use the puller and punch to force the ball race from the steering shaft.

Tools

Ball race puller

Use the ball race puller and punch to force ball race out off the steering shaft.

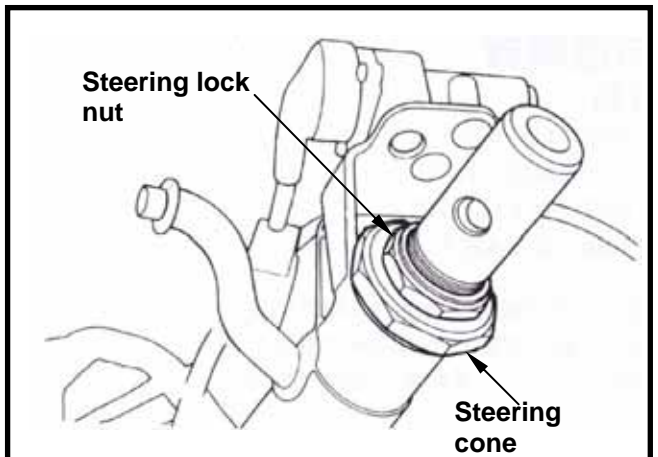
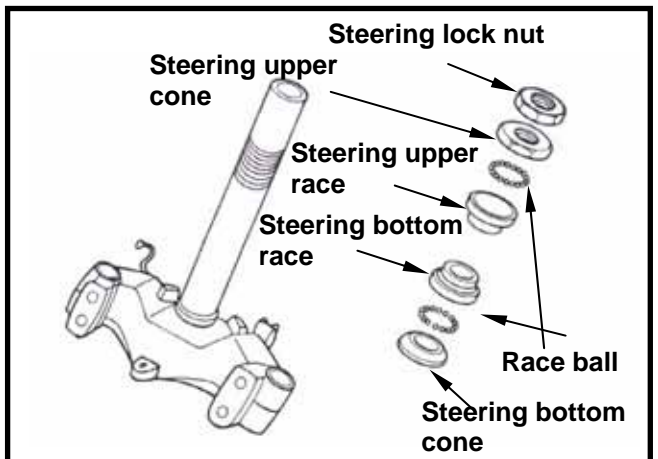
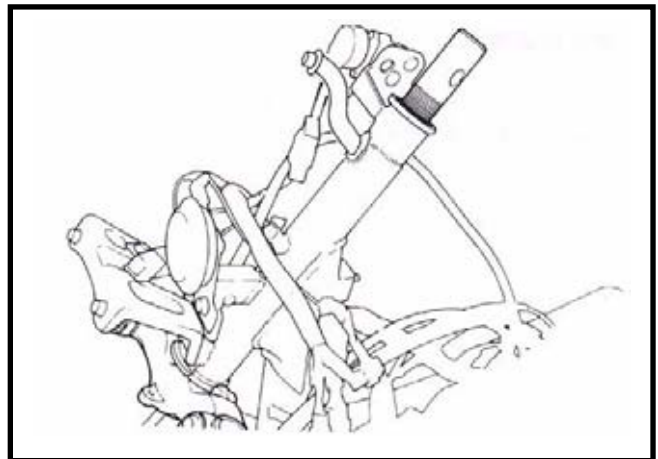
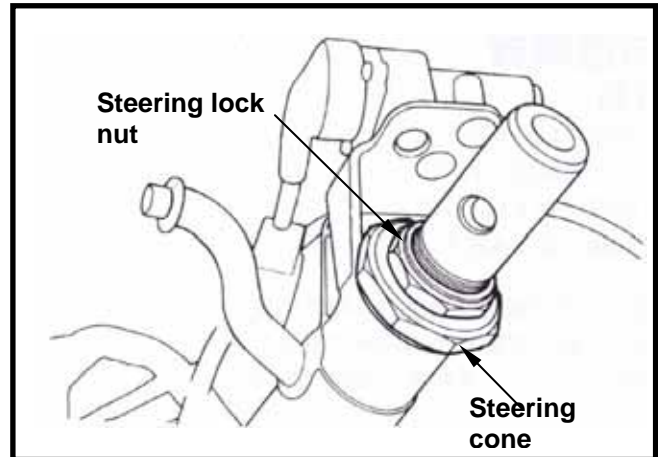

15. STEERING/FRONT WHEEL/FRONT BRAKE/FRONT CUSHION

Use the punch and the drive to press the ball race into the steering shaft end.

Tools
Driver
Punch

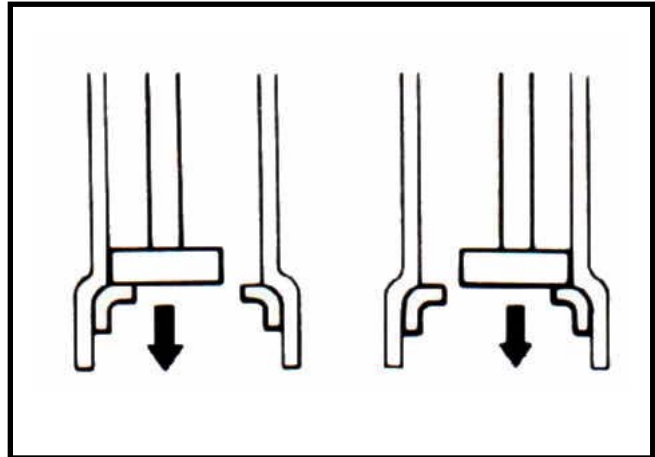

Use the punch and the driver to press the bottom ball race into the steering shaft end.

Tools
Driver
Punch

Installation of front fork

Fill the upper and lower ball race with grease, and load each carrier with balls. Install the front fork into the steering shaft. Care shall be exercised not to lose the balls.

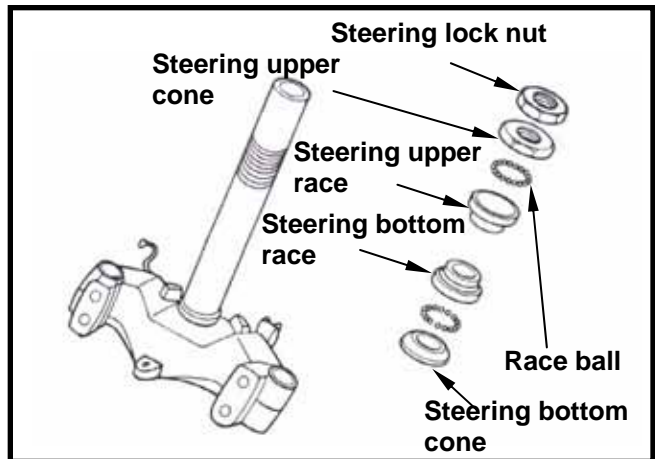

Apply a coat of grease to the top crown. Lock the top crown in place by bolts.

Caution

Check the free play and vertical clearance of the steering shaft.

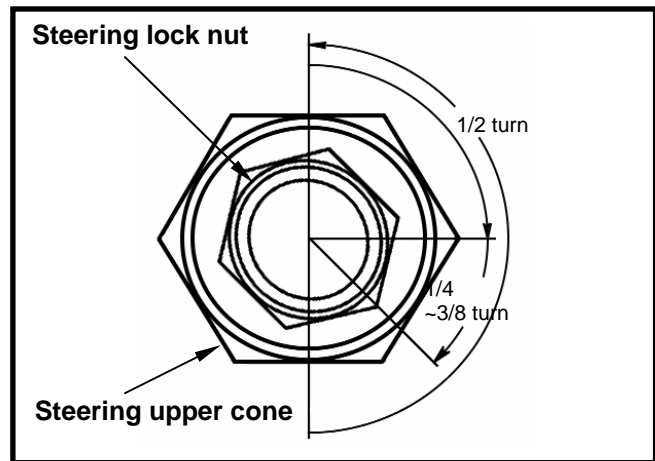

Tighten the nut of the steering shaft and lock up nuts of the top crown.

Torque value: 1.0 ~ 2.0 kgf-m

Tools
Steering shaft wrench

Installing the following parts:

- The front wheel
- The steering handlebar
- The body covers

Mechanical Illustration	16-1	Muffler	16-3
Operational Precaution.....	16-2	Rear Wheel	16-3
Trouble Diagnosis.....	16-2	Rear Cushion.....	16-5

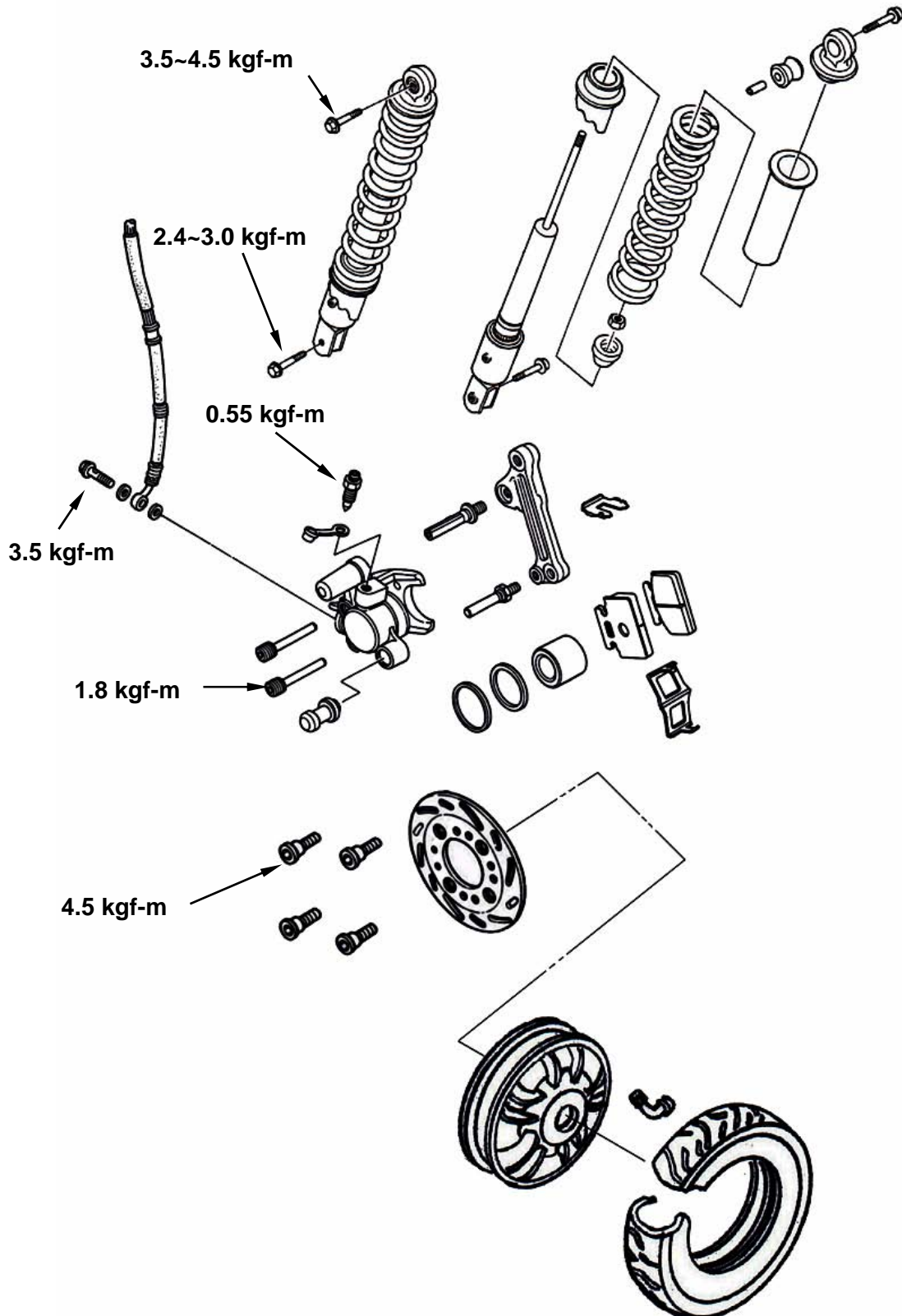

Operational Precaution

General

Please refer to the Maintenance Manual for tubeless tire in respect to the removal, repair and installation of the tires.

Service data

Unit: mm

Item	Standard	Allowable Limit
Run-out of rear rim	Radial	-
	Axial	-
Thickness of rear brake lining	4.0	2.0
Free length of rear shock absorber	238.6	233.6

Torque Value

Rear shaft nut	10.0-12.0 kgf-m	Rear cushion bolt	2.4-3.0 kgf-m
Rear brake calliper bolt	2.9-3.5 kgf-m	Exhaust pipe attaching nut	1.0~1.2 kgf-m
Rear cushion upper bolt	3.5-4.5 kgf-m	Exhaust pipe attaching bolt	2.7-3.3 kgf-m

Trouble Diagnosis

Run-out of rear wheel

- Deformed or bent wheel hub.
- Improper tires.
- Loose wheel shaft.

Soft Shock Absorber

- The spring is too weak.

Noisy Brake

- Worn brake lining.
- Offset brake disc.
- Improper assembly of brake caliper.
- Brake disc or wheel imbalance.

Poor Performance of Brake

- Improperly adjusted brake.
- Contaminated brake disc.
- Worn brake lining.
- Air inside brake fluid pipe.
- Grease on brake disc.
- The brake fluid piping is clogged.
- The brake fluid pipe is deformed or bent.
- Insufficient amount of brake fluid in the reservoir.

Muffler

Removal

Loosen the front lock nuts of the muffler (nut x2).
Loosen the lock bolts (bolt x 3).
Remove the exhaust pipe.

Installation

In reverse order of the removal.

⚠ Caution

Replace the front gasket if worn or deformed.



Torque Value

For lock bolt: 3.2 ~ 3.8 kgf-m

For lock nut: 2.7 ~ 3.3 kgf-m



Rear Wheel

Removal

Remove the rear cover (screw x 4).
Remove the right side cover (screw x 3).
Remove the muffler (bolt x 3, nut x 2).
Remove the brake hose clamp (bolt x 2).
Remove the brake clipper (bolt x 2).
Remove the lower bolts of the rear cushion (bolt x 1).
Remove the nut of the rear wheel shaft (nut x 1).
Remove the rear rocker arm.
Remove the rear wheel.

⚠ Caution

When the brake caliper is removed, never tamper with the brake lever to avoid that the brake pad is being squeezed out.



Inspection

Inspection on Brake Disc

Visually check disc for any deformation and damage.
Measure the thickness of the lining at several places. Replace if wear is beyond the specified value.

Allowable thickness: 2.0 mm



Check any deformation and warping of the brake disc.

Allowable limit: 0.3 mm

⚠ Warning

- Never contaminate the brake disc with grease. The contaminated brake disc will reduce its performance.
- The brake disc contains asbestos. Never use air jet to clean it. Preferably, the operator shall wear respirator and gloves, and use the vacuum cleaner to clean the brake disc.

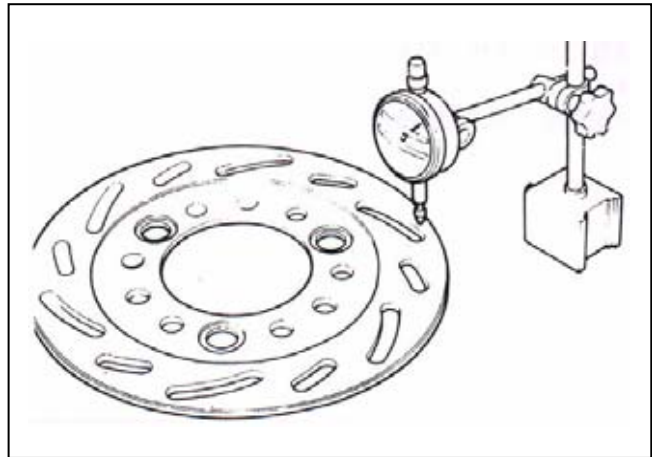

Inspection of Rear Wheel

Wheel Rim

Place the wheel rim on a rotational support. Rotate it by hand and measure the run-out with a dial indicator.

Run-out limit: 2.0 mm

Bearing

Rotate the inner ring of the bearing with a finger. The bearing should move smoothly and quietly. Check the fit of the bearing and rim. Replace the bearing if its motion is not smooth or noisy.

⚠ Caution

The bearing must be replaced in pair.

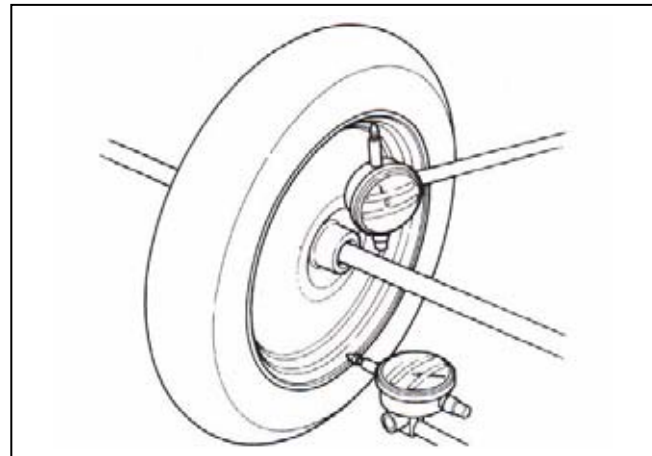

Replacement of Rear Wheel Bearing

Remove the collar and oil seal from the rocker arm.

Pull off the rear wheel bearing by means of the bearing puller.

Remove the outer oil seal.

⚠ Caution

Never reuse the old oil seal on the bearing.

Press in the oil seal and bearing into the rocker arm by employing a hydraulic presser. Install the oil seal and collar onto the rocker arm.

Installation

Install the rear wheel.

Install the collar on the rocker arm.

Install the rocker arm onto the rear wheel shaft.

Mount the outer washer on the rocker arm.

Tighten the rear wheel nuts.

Align the rear shock absorber with the rocker arms hole; tighten the cushion with bolts.
Install the brake calliper and tighten the lock bolts.
Install the muffler and tighten the lock bolts.
Install the guards and cover in reverse order of removal.

Torque Value

Cushion bolt: 2.4 ~ 3.0 kgf-m
Nuts of rear wheel shaft: 10.0 ~ 12.0 kgf-m
Bolts for the brake calliper: 2.9 ~ 3.5 kgf-m
Bolts for the muffler: 3.2 ~ 3.8 kgf-m
Nuts for the muffler: 2.7 ~ 3.3 kgf-m

⚠ Caution

Attention must be paid to their direction when rocker arm collars are installed. The small ends of inner and outer collars must face to rocker arm bearing.

Rear Cushion

Removal

Remove the rear cover (screw x 4).
Remove the right side cover (screw x 3).
Remove the luggage box (bolt x 6, screw x 1).
Remove the body cover (bolt x 2, screw x 2).
Loosen the lock bolts of the air filter (bolt x 2).
Remove the muffler (bolt x 3, nut x 2).
Remove the rear fender assembly (bolt x 2, screw x 2).
Remove the left / right rear cushions.

Removal

Remove a lower bolt from the shock absorber (bolt x 1).



16. REAR WHEEL/REAR BRAKE/REAR CUSHION



Remove an upper bolt from the shock absorber (bolt x 1).
Remove the rear shock absorber.



Installation

In reverse order of removal.

⚠ Caution

The shock absorber must be replaced as a unit. Never disassemble the shock absorber as that would damage the structure.

Torque Value

Absorbing bolt: 2.4 ~ 3.0 kgf-m

Lock nut: 3.5 ~ 4.5 kgf-m

Mechanical Illustration	17-1	Lamp/Bulb	17-12
Maintenance Data.....	17-2	Switch/Horn.....	17-13
Trouble Diagnosis.....	17-3	Fuel Gauge	17-16
Battery.....	17-4	Thermal Switch	17-17
Charging System.....	17-5	Sensor.....	17-18
Ignition System	17-8	Digital meters trouble diagnosis ..	17-19
Starting System.....	17-10		

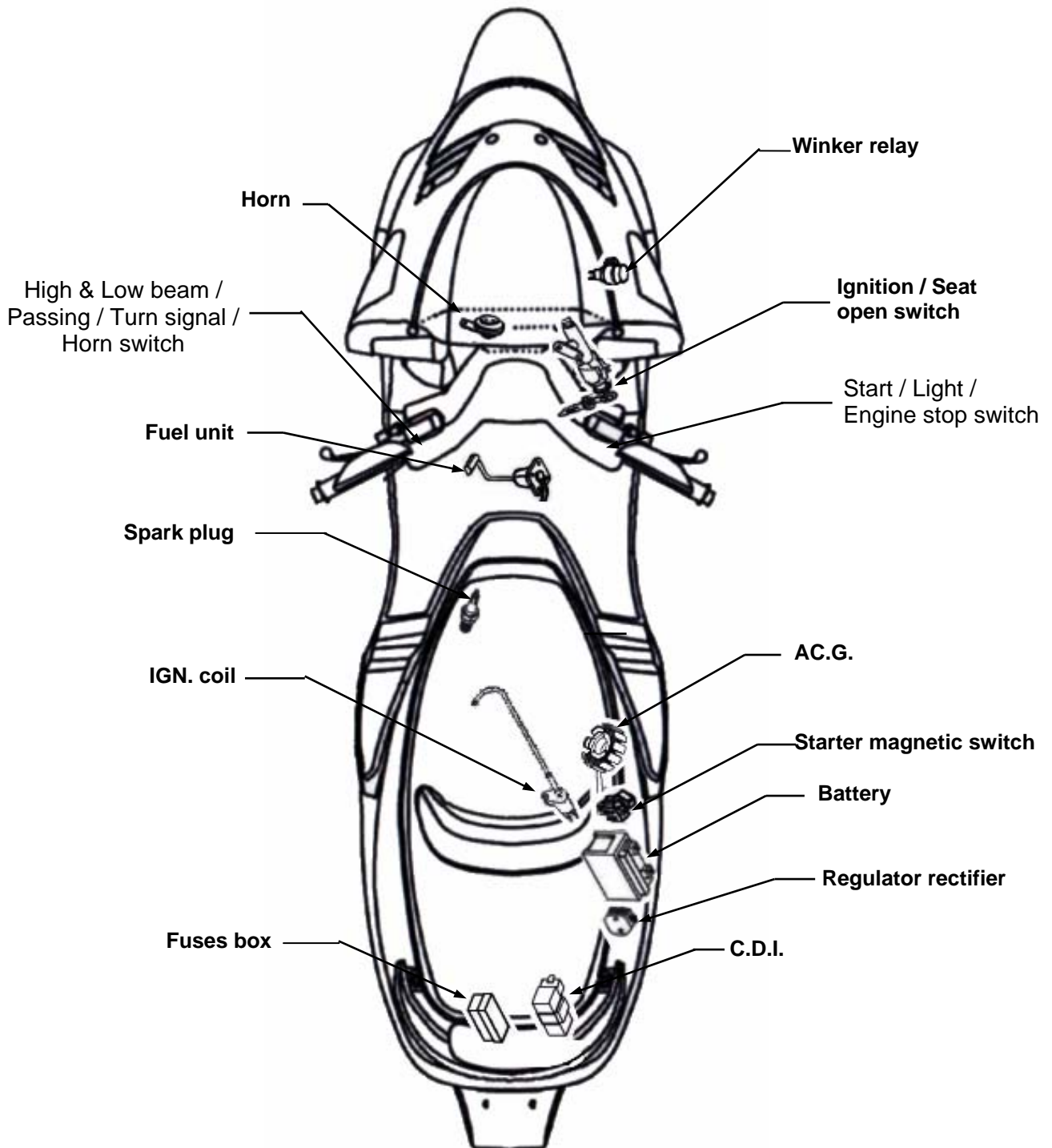

Maintenance Data

Operational Precaution

- When remove the battery, the disconnection sequence of cable terminals shall be strictly observed. (First disconnect the negative cable terminal, next, the positive cable terminal.)
- The model of the spark plug and the tightening torque.
- The ignition timing.
- Adjustment of headlamp.
- Removal and installation of AC generator.
- The maintenance free battery requires no inspection of electrolyte level and refilling of distilled water.
- To recharge the battery, remove the battery from rack without removing ventilation caps.
- Unless in emergency, never rapid charge the battery.
- The voltage must be checked with the voltmeter while charging the battery.
- As C.D.I assembly does not require an ignition timing check. In case ignition timing is incorrect, check C.D.I and AC generator. Verify with an ignition timing lamp after replacement if necessary.

Technical Specification

Charging System

Description		Specification
Battery	Capacity	12V8Ah
	Charging rate	0.17A / 5 hours (standard) 17A / 0.5 hour (fast charging)
Leak current		< 1 mA
Charging current		1.2 A / 2000 rpm
Control voltage in charging		15.0 + 0.5 V

Ignition System

Description		Specification
Spark plug	Model	NGK CR8E (Recommended)
	Gap	0.6 - 0.7 mm
Ignition coil and resistance	Primary winding	0.17 ± 10% Ω
	Secondary winding	Without cap: 3.1 ± 10 KΩ
With cap: 8.1 ± 10 KΩ		
Ignition timing "F" mark		13° TDC / 1000 rpm
		27° TDC / 6000 rpm

Trouble Diagnosis

No voltage

- Battery discharged
- The cable disconnected
- The fuse is blown
- Improper operation of the main switch

Low voltage

- The battery is not fully charged
- Poor contact
- Poor charging system
- Poor voltage regulator

No spark produced by spark plug

- The spark plug is out of work
- The cable is poorly connected, open or short-circuited
 - Between AC.G. and C.D.I.
- Poor connection between C.D.I. and ignition coil
 - Poor connection between C.D.I. and the main switch
- Poor main switch
- Poor C.D.I.
- AC.G. is out of work

Starter motor does not work

- The fuse is blown
- The battery is not fully charge
- Poor main switch
- Poor starter switch
- The front and rear brake switches do not operate correctly
- Starter relay is out of work
- The ignition coil is poorly connected, open or short-circuited
- The starter motor is out of work

Intermittent power supply

- The connector of the charging system becomes loose
- Poor connection of the battery cable
- Poor connection or short-circuit of the discharging system
- Poor connection or short-circuit of the power generation system

Charging system does not operate properly

- Burnt fuse
- Poor contact, open or short circuit
- Poor regulator
- Poor ACG

Engine does not crank smoothly

- Primary winding circuit
 - Poor ignition coil
 - Poor connection of cable and connectors
 - Poor main switch
- Secondary winding circuit
 - Poor ignition coil
 - Poor spark plug
 - Poor ignition coil cable
 - Current leakage in the spark plug
- Incorrect ignition timing
 - Poor AC.G.
 - Improper installation of the pulse sensor
 - Poor C.D.I.

Weak starter motor

- Poor charging system
- The battery is not fully charged
- Poor connection in the windings
- The motor gear is jammed by foreign material

Starter motor is working, but engine does not crank

- Poor starter motor pinion
- The starter motor run in reverse direction
- Poor battery

Battery

Removal

Loosen four screws and remove the rear cover (screw x 4).

Loosen three screws and remove the right body cover (screw x 3).

Loosen two nuts and remove the battery guard cover (nut x 2).

Disconnect the negative cable terminal first, then the positive cable terminal.

Remove the battery from the motorcycle.

Voltage Check

Use the digital voltmeter to check the voltage of the battery.

Voltage:

Fully charged: 13.0 – 13.2 V at 20°C

Undercharged: Below 12.3 V at 20°C

Charging

Connect the positive terminal (+) of the charger to the battery positive terminal (+).

Connect the negative terminal (-) of the charger to the battery negative terminal (-).

	Standard	Maximum
Charging current	0.9A	4.0A
Charging time	5H	1H

Warning

- Keep flames away while recharging.
- Charging is completely controlled by the ON/OFF switch on the charger, not by battery cables.

Caution

- Never rapid charge the battery unless in emergency.
- Verify the battery is recharged with current and duration prescribed above.
- Large current and fast time to charge will render damage to the battery.

When installing the battery, coat the cable terminal with grease.

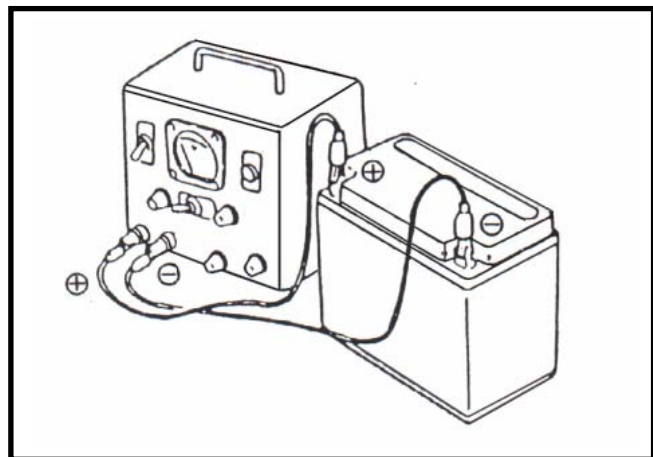
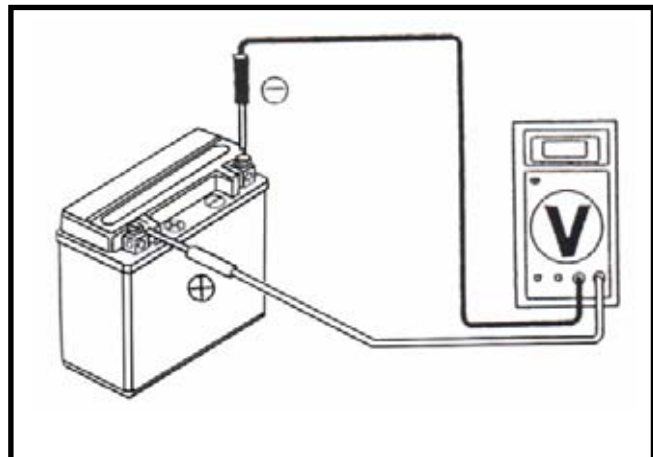

Charging System

Charging Circuit

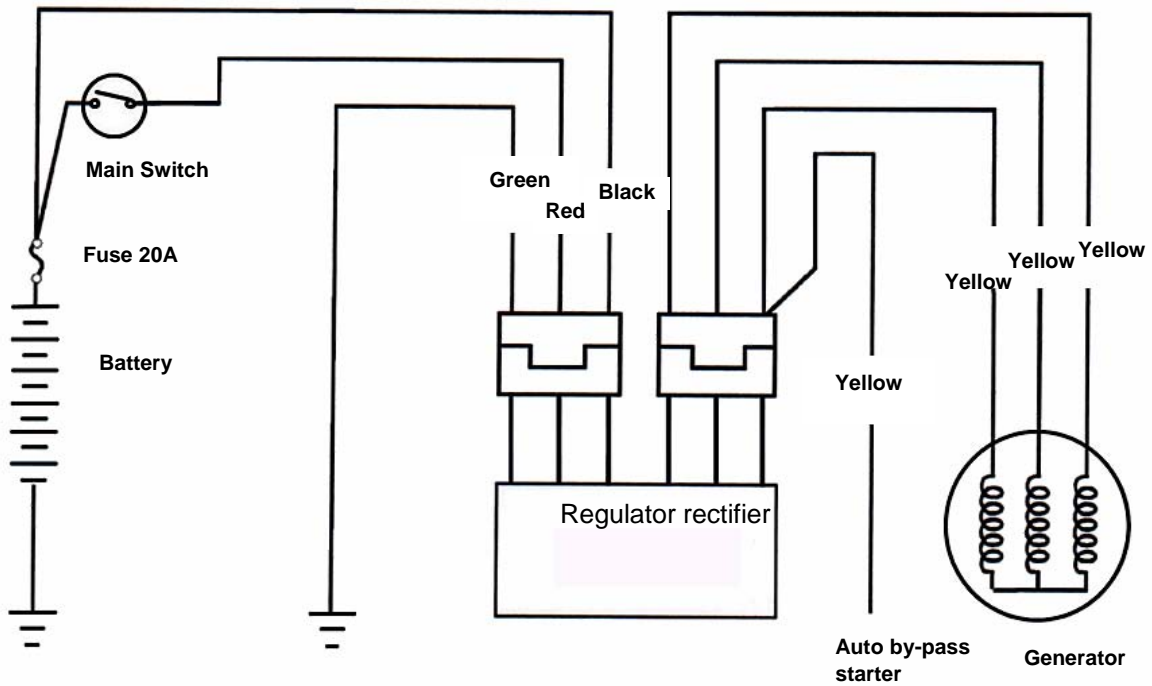

Current Leakage Test

Current Leakage Inspection

Turn the main switch to OFF position, and remove the negative cable terminal (-) from the battery.

Connect an ammeter between the negative cable terminal and the battery negative terminal.

Caution

- In the current leakage test, set the current range at the largest scale, then gradually decrease to the lower scale as the test process goes to avoid possible damage to the ammeter and the fuse.
- Do not turn the main switch to ON position during test.

If the leaked current exceeds the specified value, it may indicate a short circuit.

Allowable current leakage: Less than 1 mA
Disconnect each cable one by one and take measurement of the current of each cable to locate the short circuit.

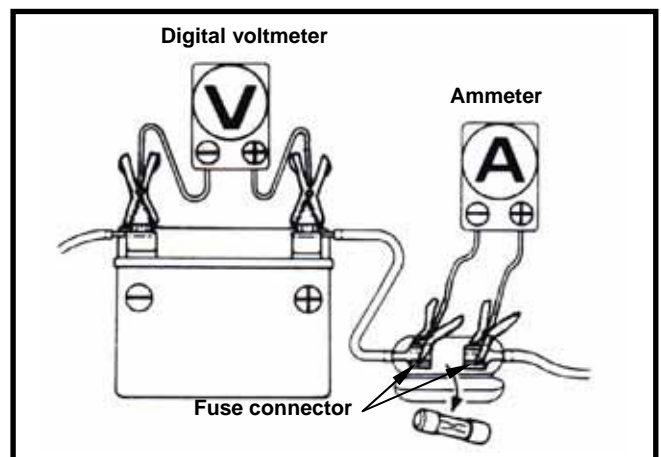
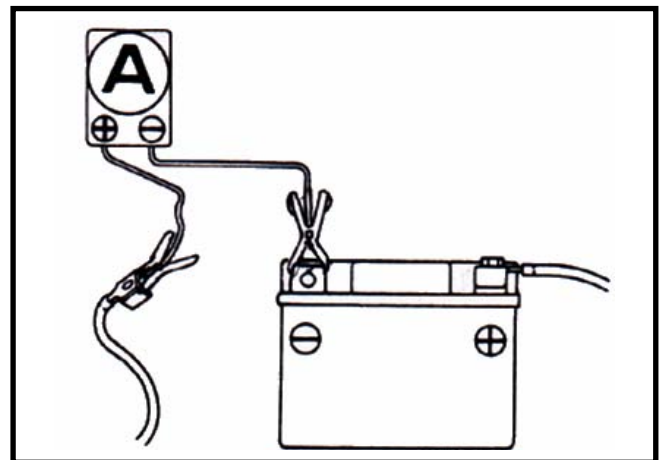

Inspection on Charging Voltage

Caution

- Before conducting the inspection, be sure that the battery is fully charged. If undercharged, the current changes dramatically.
- Use a fully charged battery having a voltage larger than 13.0 V
- While starting the engine, the starter motor draws large amount of current from the battery.

After the engine is warmed up, replace original battery with a fully charged battery. Connect a digital voltmeter to the battery terminals. Connect an ammeter between both ends of the main fuse.

Caution

When the probe is reversibly connected, use a voltmeter having an indication that the current flows from the positive or the negative direction and the measurement should be at zero, ammeter at one direction only.

Caution

- Do not use short-circuit cable.
- It is possible to measure the current by connecting an ammeter between the battery positive terminal and the cable position terminal, however, while the starter motor is activated, the surge current the motor draws from the battery may damage the ammeter. Use the kick starter to start the engine.
- The main switch shall be turned to OFF position during the process of inspection. Never tamper with the ammeter and the cable while there is current flowing through. It may damage the ammeter.

Connect a tachometer.

Turn on the headlamp to high beam and start the engine.

Accelerate the engine to the specified revolution per minute and measure the charging voltage.

Specified Charging Current:

1.2 A / 2000 rpm

Control Charging Voltage:

15.0 + 0.5 V / 2000 rpm

Caution

To replace the old battery, use a new battery with the same current and voltage.

The following problems are related to the charging system, follow the instructions provided in the checking list to correct it if any one of the problems takes place.

- (1) The charging voltage can not exceed the voltage between two battery terminals and the charging current is in the discharging direction.
- (2) The charging voltage and current are too much higher than the standard values.

The following problems are not related to the charging system; correct it if any by following steps indicate in the checking list.

- (1) The standard charging voltage and current can only reach when the revolution of the engine exceeds the specified rpm.
 - Bulbs used exceed their rate and consume too much power.
 - The replacement battery is aged and does not have enough capacity.
- (2) The charging voltage is normal, but the current is not.
 - The replacement battery is aged and does not have enough capacity.
 - Battery used do not have enough electricity or is over charged.
 - The fuse of the ammeter is blown.
 - The ammeter is improperly connected.
- (3) The charging current is normal, but the voltage is not.
 - The fuse of the voltmeter is blown.

Inspection on SCR

Remove the bumper by loosening four screws (screw x 4).

Remove the right side cover by loosening three screws (screw x 3).

Disconnect 3P and 4P connectors to remove the SCR.

Item	Check Points	Standard Value
Main switch connection	R – B	Battery voltage (ON)
Battery connection	R – G	Battery voltage
Charging coil	Y – Y	0.4 – 0.8Ω

If the readings measured are not normal, check parts in the circuit.

If the parts are normal, then trouble is in the wiring.

If there is nothing wrong with parts and wiring, replace the SCR.

Inspection on the Charging Coil

Caution

The test can be carried out without removing the charging coil from the engine.

Measure the resistance between each yellow wire of the SCR.

Standard resistance: 0.4-0.8Ω

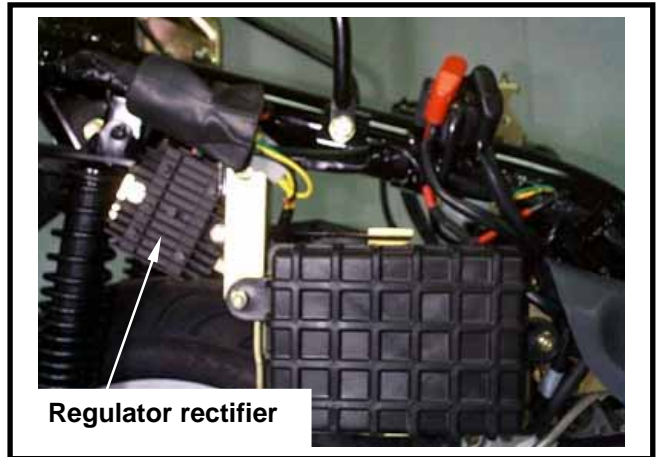
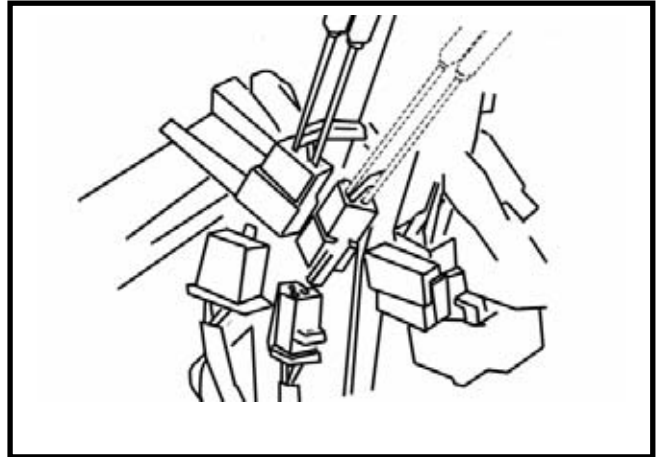

Ignition System

Ignition circuit diagram

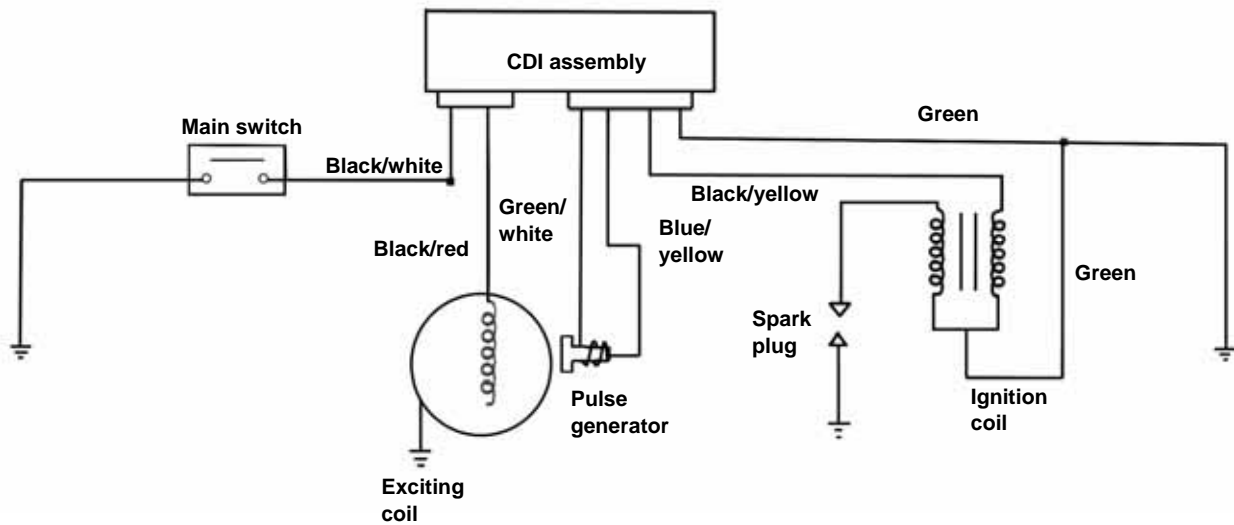

C.D.I Assembly

Disconnect connectors of the C.D.I assembly.

Check the following connectors as indicated in the table at the harness side.

Item		Points to check	Result
Main switch		Black/white/green	
Exciting coil		Black/red/green	100-200
Pulse generator		Green/White/Blue/yellow	50-170
Ignition coil	Primary circuit	Black/yellow/green	0.17±10%
	Secondary circuit	Black/yellow/with no cap	3.6±10%
		Black/yellow/with cap	7.3-11K

Inspection on Ignition Coil

Remove the luggage box.

Disengage the connector of the ignition coil and the spark plug cap.

Measure the resistance between the terminals of the primary winding.

Standard resistance: $0.17\ \Omega \pm 10\%$

Remove the cap from the spark plug and measure the resistance between the spark plug and the primary winding.

Standard resistance:

With no cap: $3.6\ \Omega \pm 10\%$

With cap: 7.3 - 11 K Ω

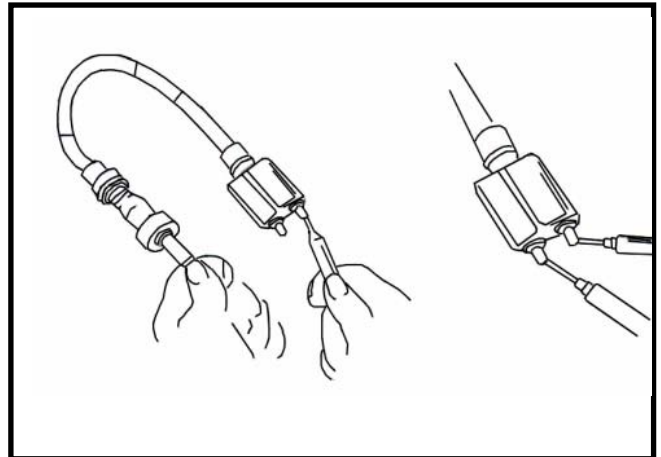

Replacement

Loosen the lock bolt and replace the ignition coil if necessary.

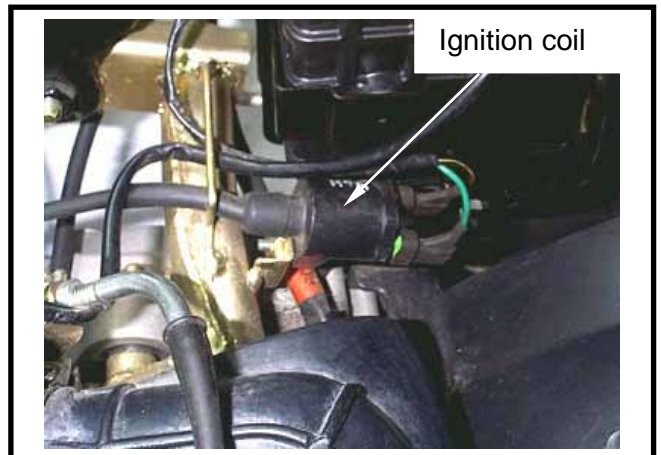

Inspection on Exciting Coil

Caution

The test can be carried out without removing the exciting coil from the engine.

Removing the bumper by loosening four screws (screw x 4).

Remove the right side cover by loosening three screws (screw x 3).

Measure the resistance between the black red terminal and the earth.

Standard resistance: 100 - 200 Ω

Caution

Pick up x 1 Ω mark for measuring.

Please refer to the Section 10 for disassembly of coil.



Inspection of Pulse Generator

Disconnect the connector of the pulse generator and measure the resistance between the terminals of green/white and blue/yellow.

Standard resistance: 50-170 Ω

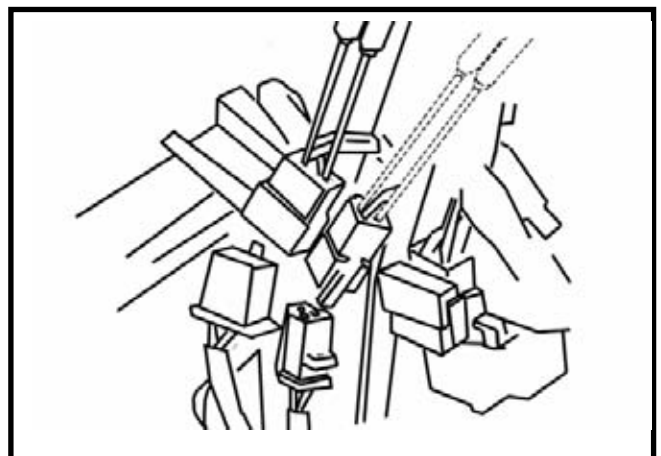

Starting System

Starting Circuit Diagram

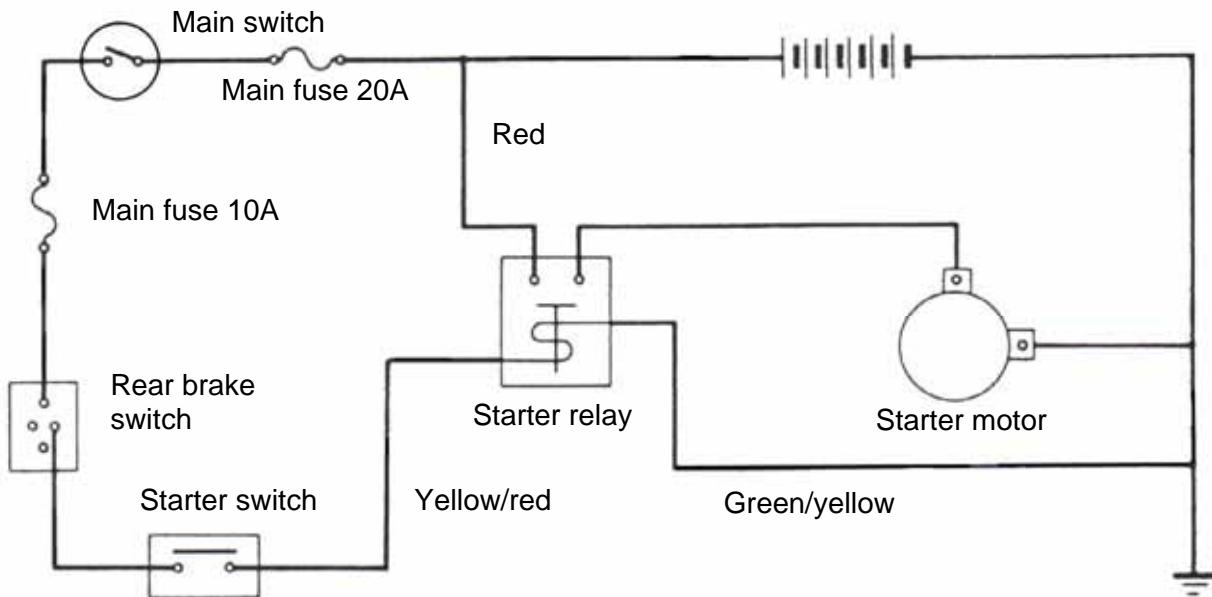

Inspection on Starter Relay

- Remove the luggage box assembly.
- Open the main switch
- Press the brake
- Push down the starter switch
- If a sound of "Looh Looh" is heard, it indicates the relay function normally.



- Disconnect the cable positive terminal from the relay.
- Disconnect the positive cable of the starter motor.
- Disconnect the connector of the relay.
- Connect an ohmmeter to the large terminal end.
- Connect the yellow/red cable to the battery positive terminal and the green/yellow cable to the battery negative terminal.
- Check the continuity of the large terminal end.
- If there is no continuity, replace the relay.



Removal of Starter motor

Remove the rear cover (screw x 4).
 Remove the right body cover (screw x 3).
 Remove the battery cover (nut x 2).
 Disconnect the cable negative terminal (-), then the cable positive terminal (+).
 Remove the luggage box.
 Loosen the lock bolt and remove the starter motor.

Installation of Starter motor

In reverse order of the removal of the starter motor.

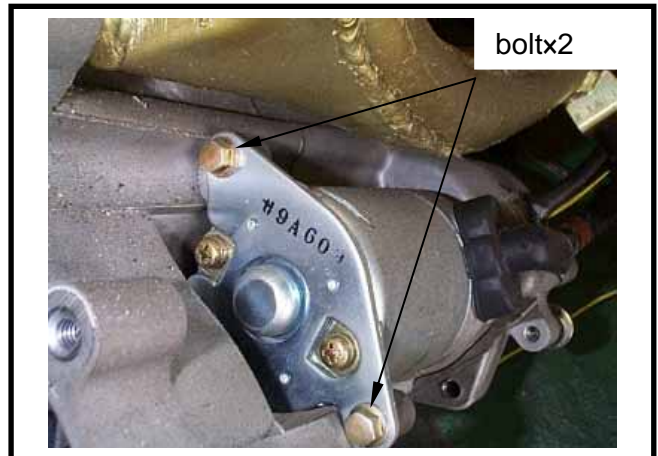

Meters

Removal

Loosen lock bolts and remove from the front handlebar guard (bolt x 2).
 Loosen screws from the lower part of the front handlebar guard (screw x 4).
 Loosen screws from the front luggage carrier (screw x 4).
 Disconnect the connectors for the headlamp and direction indication lamps.
 Remove the front guard.
 Disconnect the connector of the dashboard.
 Loosen the cable for the speedometer.
 Disconnect the connection for the dashboard.
 Loosen lock bolts under the tachometer (bolt x 2).
 Loosen screws from the tachometer cover (screw x 4).
 Loosen lock screws from the odometer (screw x 4).

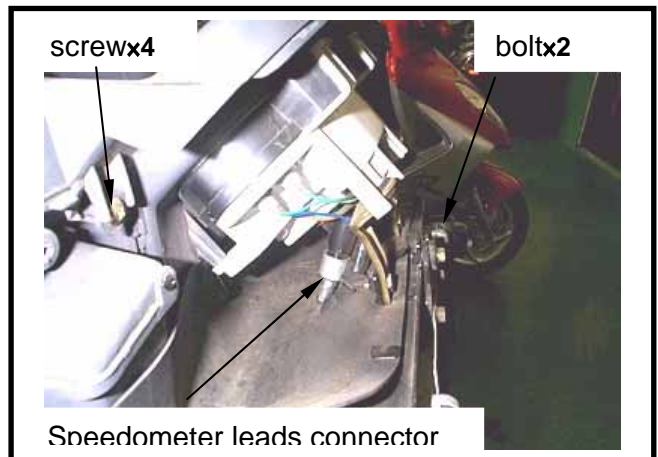

Remove the meter.

Installation of the meter

In reverse order of the removal.

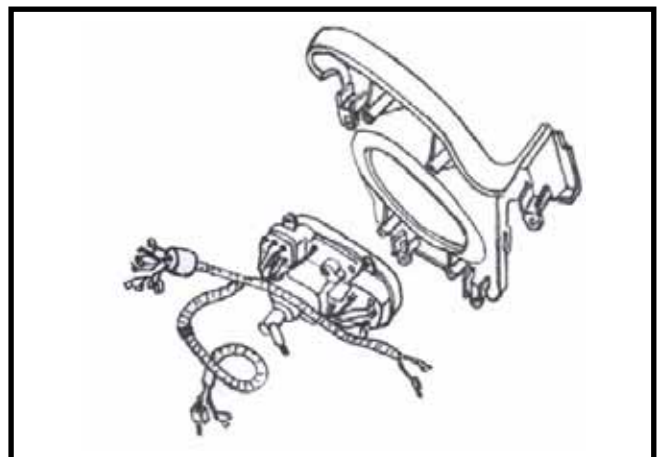

Lamp/Bulb

Replacing Bulb for Headlamp

Loosen the front cover (bolt x 2, screw x 8).

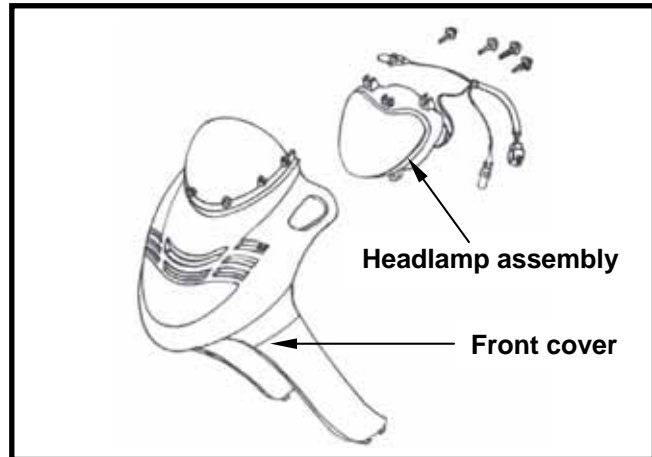

Disconnect the terminal connector and the rubber sleeve from the headlamp. Remove the bulb spring holder and the bulb. Replace with new bulb if necessary.

Caution

- Never touch the bulb with finger, which will create a heat point.
- Clean the fingerprint left on the bulb with alcohol.

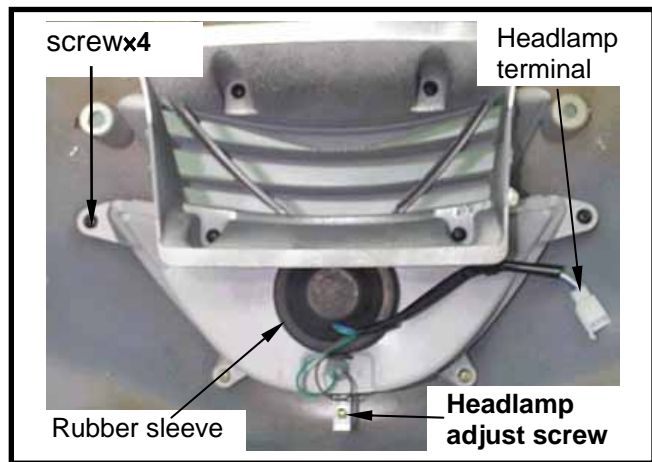

Install the bulb of the headlamp in reverse order of removal. Upon completion of replacement, turn on the main switch to ensure the headlamp works well. Adjust the beam and distance of the headlamp if necessary.

Replacing the Front winker light Bulb

Loosen fixing screws and remove the lamp lens (screw x 2). Replace with new front winker light bulb.

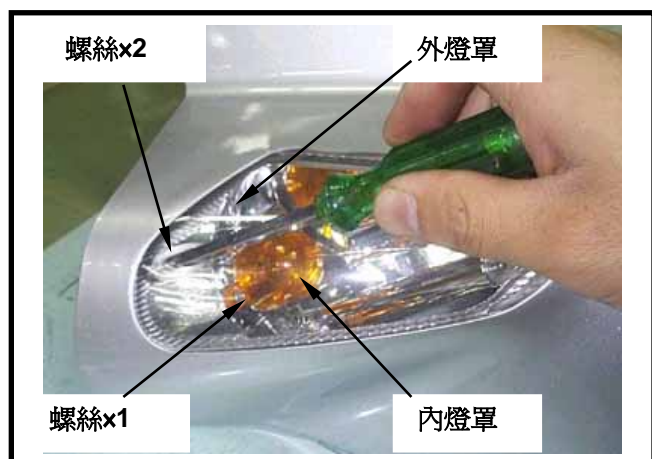

Replacing Bulb of Number Plate Lamp

Remove the rear cover (screw x 4).
Remove the lamp lens (screw x 2).

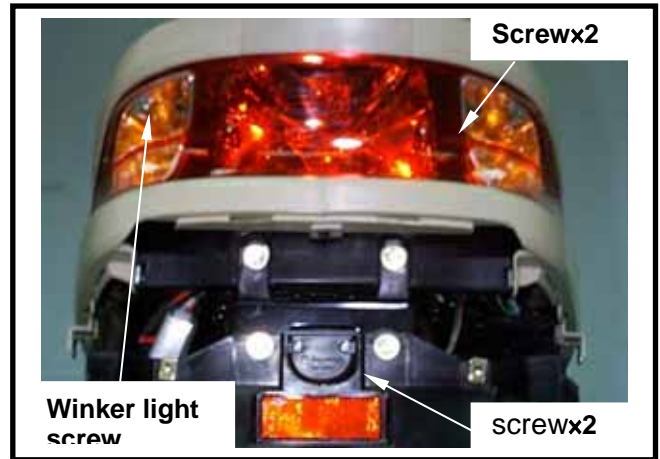

Replacing bulbs of Tail light, Brake light, and Rear winker light

Remove the rear cover (screw x 4).
Remove the lamp lens for tail light and rear winker light (screw x 4).

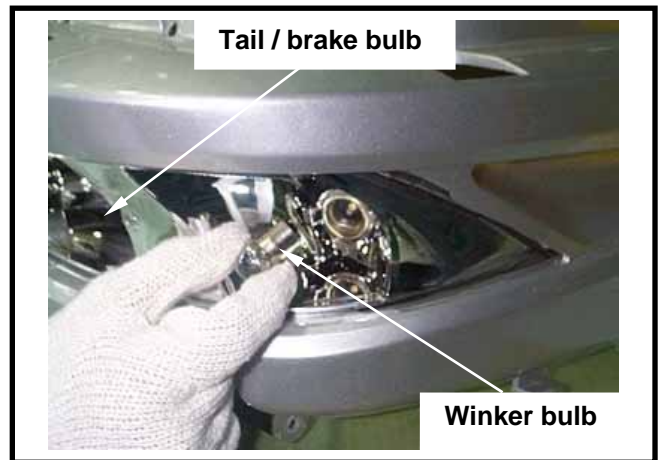

Switch/Horn

Main Switch

Inspection

Remove the front cover (bolt x 2, screw x 8).
Disconnect the main switch.
Check the continuity between two points as indicated below:

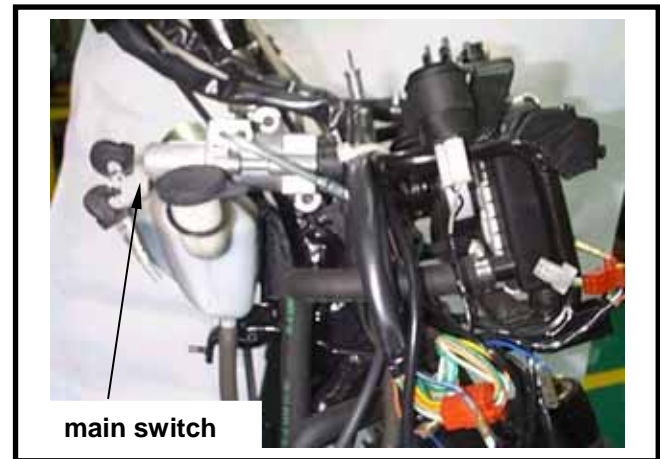

	BAT1	BAT2	IG	E
LOCK			● — ●	●
OFF			● — ●	●
ON	● — ●			
Wire Color	Red	Black	Black/White	Green

※This inspection table is also applicable to the engine switch.

Replacement of Main Switch

Disconnect the connector of the main switch and loosen the lock bolts (bolt x 2).
 Remove the main switch.
 Install the new main switch and tighten the lock bolts (bolt x 2).

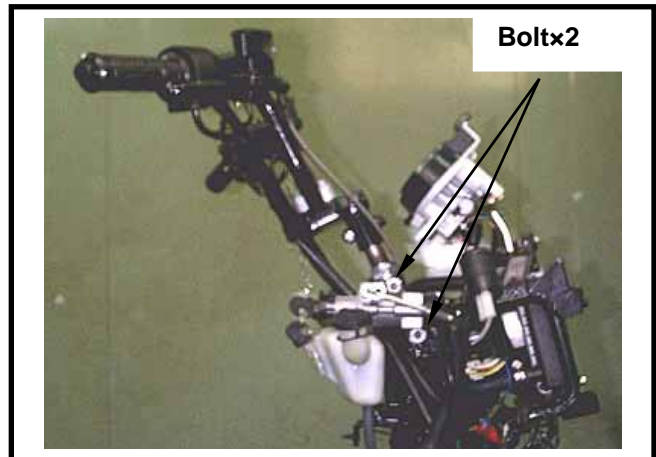

Steering Handlebar Switch

Remove the front handlebar guard (bolt x 2, screw x 8).
 Disconnect the connector of steering handlebar switch.
 Check the continuity between two points as indicated in the table below.

ENG. Stop / Starter Motor Switch

	IG	E	ST	BAT2
	●	●		
FREE				
			●	●
Wire Color	Blake/white	Green	Yellow/red	Green

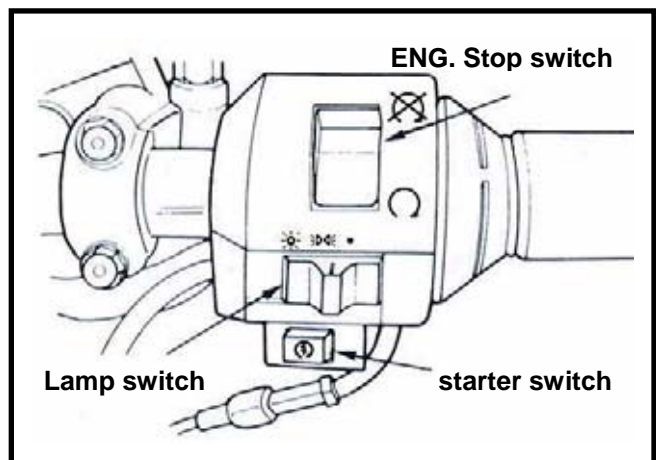

Lamp Switch

	BAT3	TL	HL
●			
	●	●	
	●	●	●
Wire Color	White/Green	Brown	Blue/White

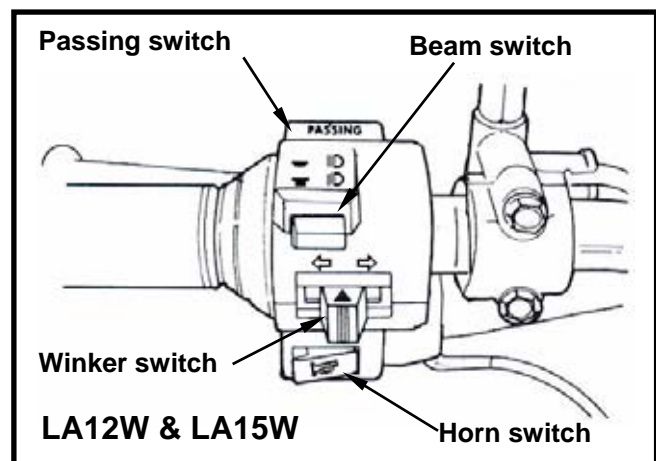

High and Low Beam Shift Switch

	LO	HL	HI
		●	●
	●	●	
Wire Color	White	Blue/White	Blue

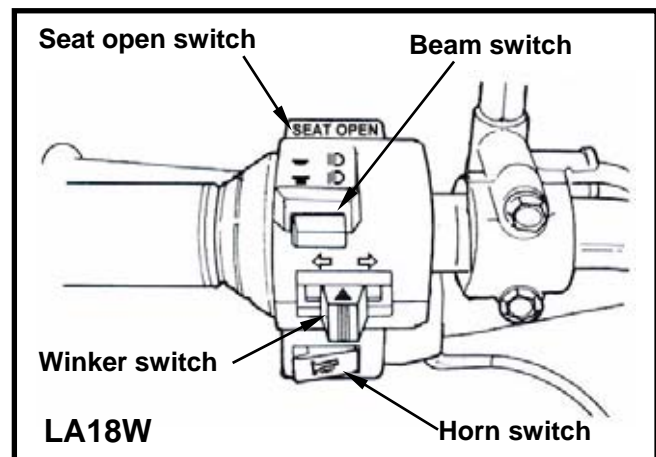

Winker light

		R	WR	L
N	➡ R	● — ●		
	PUSH OFF			
	⬅ L		● — ●	
Wire Color		Light blue	Gray	Orange

Horn switch

		BAT3	HO
FREE			
		● — ●	
Wire Color		White/ Green	Light green

Brake Switch

While grasp the brake lever firmly, the terminals of white/green and green/yellow of the brake should have continuity.
Replace the switch if damaged.

Seat open switch(LA18W)

		B1	B2
FREE			
SEAT OPEN		● — ●	
Wire Color		Black	Purple

Passing switch(LA12W & LA15W)

		BAT4	HI
FREE			
PASSING		● — ●	
Wire Color		White/ Green	Blue

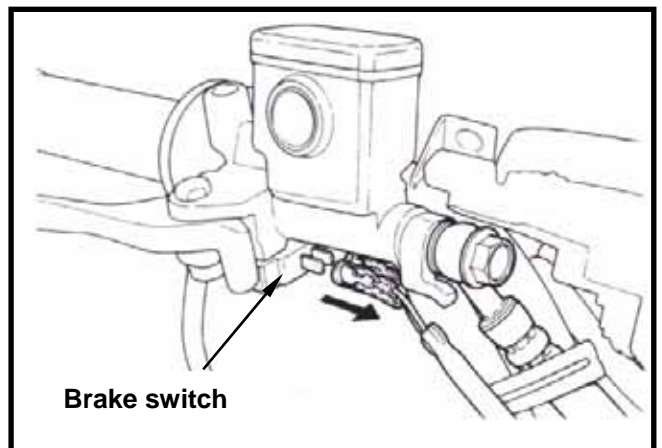

Horn

Remove the front handlebar guard.
Apply 12 V power source to two terminals of the horn, the horn should sound.
Replace the horn if necessary.

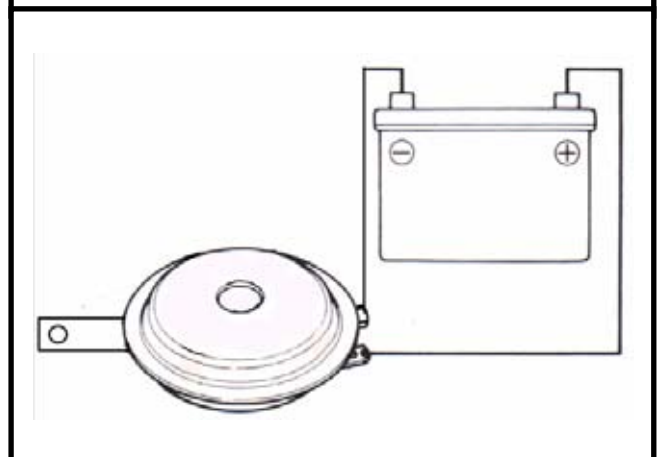

Fuel Gauge

- Open the seat.
- Remove the luggage box (bolt x 6, screw x 1).
- Remove the rear carrier (bolt x 3).
- Remove the rear carrier seat (bolt x 2).
- Remove the rear center cover (screw x 4).
- Remove the left and right rear foot rest (bolt x1).
- Remove the left and right side cover (screw x 4).
- Remove the central cover (screw x 6).
- Remove the left and right body cover, the center cover (screw x 4, bolt x 4).
- Remove the foot rest (bolt x 4, screw x 4).
- Disconnect the terminals of the fuel gauge.
- Remove the fuel gauge (screw x 4).

Caution

Great care shall be taken not to damage or bend the float arm of the gauge.

When the float arm shifts to the F position or the E position, the resistance measured shall be as follows:

Position	Resistance
E (Empty)	$750 \pm 20 \Omega$
F (Full)	$80 \pm 5 \Omega$

Connect the wiring to the fuel gauge and the ohmmeter as shown.
Turn on the main switch.
Move the float arm to verify the proper position the needle indicates.

Caution

While conducting the test, turn on the direction indication lamp to make sure that the battery is in serviceable condition.

Arm Position	Needle Position
Up (Full)	F (Full)
Down (Empty)	E (Empty)

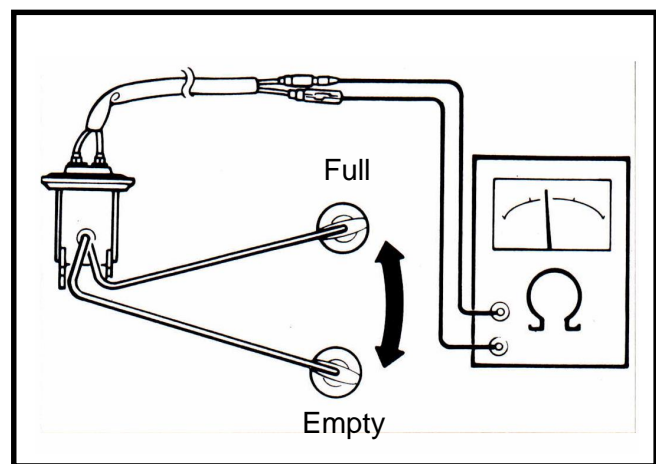
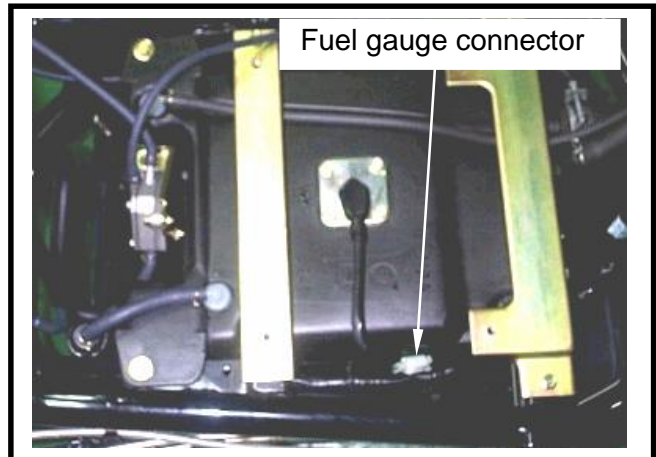

Thermal Switch

The thermal switch mounted on the radiator controls the operation of the cooling fan motor. In case that the fan motor fails to work, disconnect the green and black/blue leads and connect jump wires to the terminals, then, turn on the switch, the fan motor should operate. If the fan motor still fails to run, measure battery voltage between the green and black/blue leads. If there is no voltage, check for blown fuse, loose connection or short-circuit. If the fan motor runs, check the thermal switch in the manner as described below:
 Hang the thermal switch on the bowl filled with coolant to check the switch's opening and closing temperatures, confirm the switch is open circuited at room temperature, increase the coolant temperature gradually. The switch should have a continuity at 98-102°C.

Caution

- Keep the coolant at a constant temperature at least for three minutes. Sudden increase the coolant temperature will cause the thermometer and the tester to indicate wrong readings.
- Never let the thermometer and the thermal switch contact the wall of the bowl, which may result in wrong readings.
- The thermal switch shall be placed in the coolant until the teeth are completely submerged.

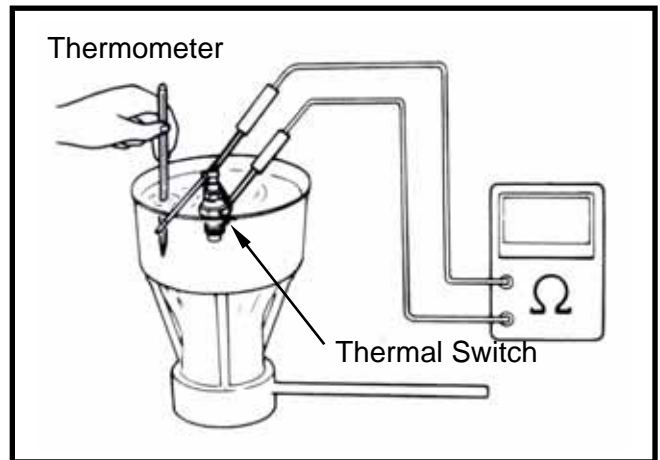
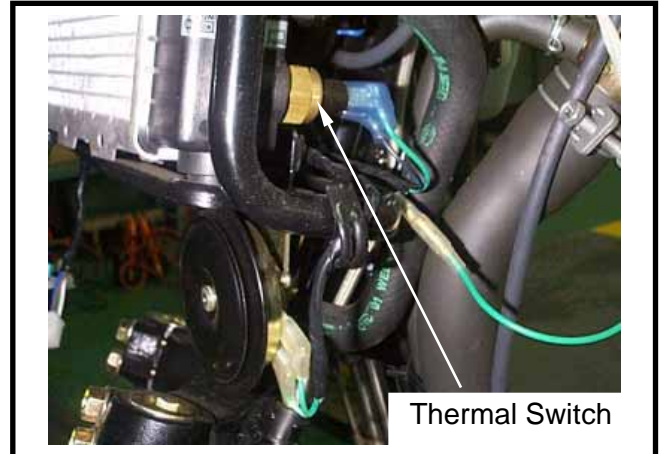

Sensor

Remove the sensor.

Hang the sensor in an oil heater, heat the oil and measure the resistance at each temperature.

Temperature	50°C	80°C	100°C	120°C
Standard (Ω)	134~149	47.5~57.0	26~29	14.8~17.2

Caution

Wear gloves and goggles when performing this test.

Caution

- Engine oil should be used as a heating medium as the test temperature must be higher than 100°C.
- Contacting the container wall by the thermometer and the sensor may result in wrong readings.

Water Temperature Meter

Disconnect the water temperature meter and connect it to engine ground.

Turn on the main switch.

The needle of the meter should move to other end, H position.

Caution

Do not ground the water temperature more than 5 seconds, or the meter will be damaged.

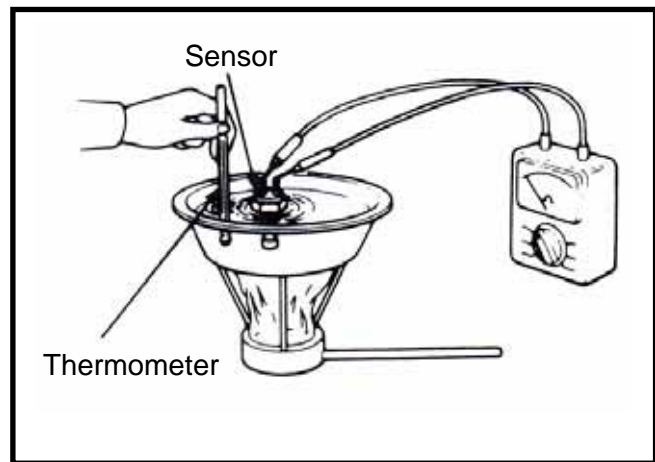
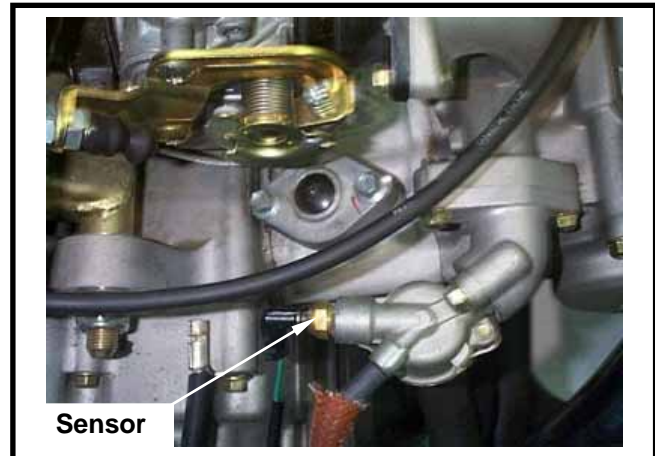

Gauges

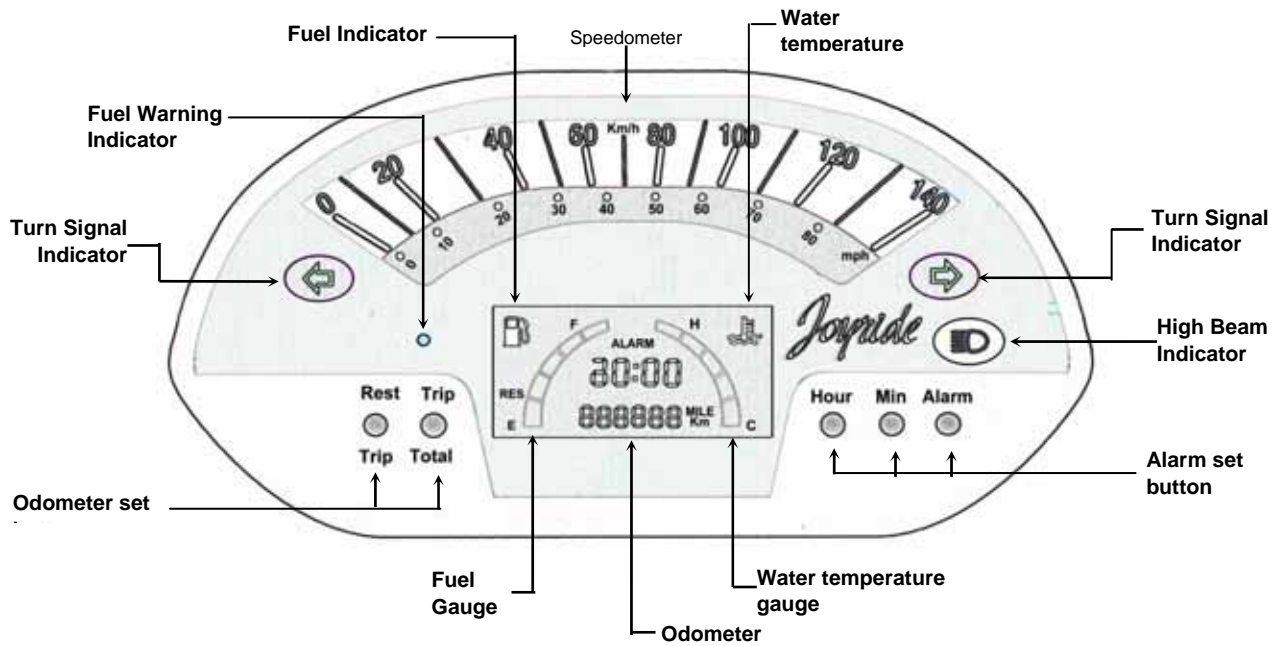

Digital meters trouble diagnosis

1. The meter doesn't indicate

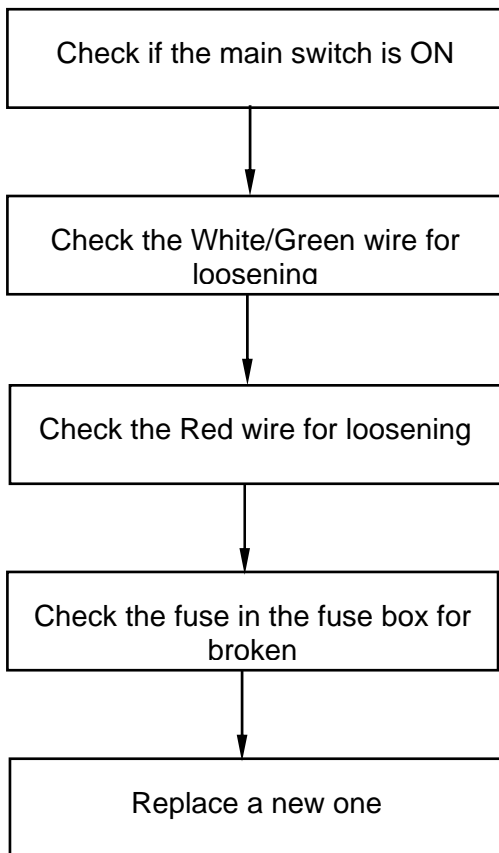

2.The monitor indicates but doesn't work:

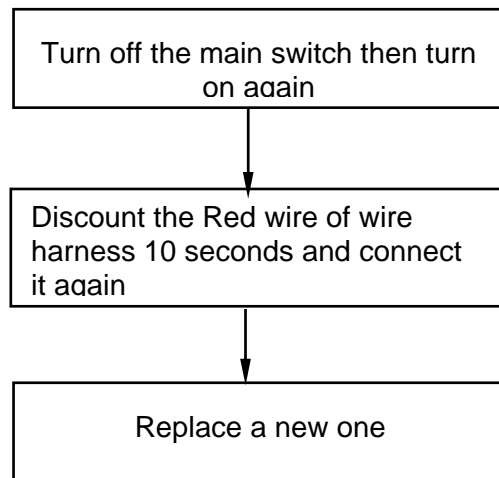

3.Water temperature is too high

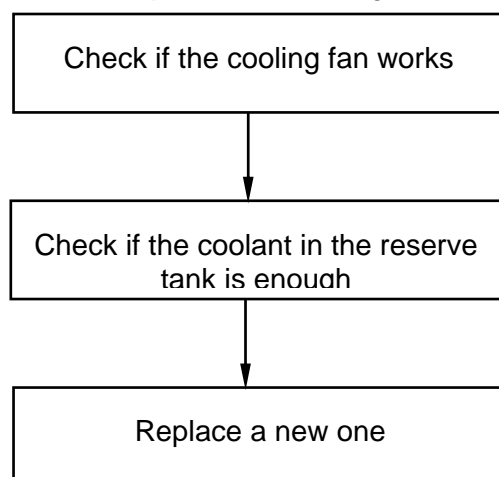

NOTES:

Special tools list.....19-1	Crank case / transmission oil seal driver..... 19-7
How to use special tools19-4	AC.G. flywheel puller..... 19-8
R/L. Crank case disassemble / install tools19-4	Valve cotter remover / install driver ... 19-8
Bearing driver19-5	Outer / inner bearing puller..... 19-9
Water pump bearing / seal driver...19-6	Crank case bush puller19-10

H9A ENG. REMOVE. ASSEMBLY. ADJUSTER SPECIAL TOOLS LIST

1		2		3	
					
NAME	R/L. CRANK DISASS. TOOL	NAME	CRANK SHAFT PULLER	NAME	CRANK SHAFT BRG. FIXING SOCKET
NO.	SYM-1120000-H9A	NO.	SYM-1130000-H9A	NO.	SYM-9100210-H9A
4		5		6	
					
NAME	L. CRANK SHAFT BRG. DRIVER	NAME	BEARING DRIVER	NAME	BEARING DRIVER
NO.	SYM-9100200-H9A	NO.	SYM-9110400	NO.	SYM-9610000
7		8		9	
					
NAME	BEARING DRIVER	NAME	WATER PUMP BEARING DRIVER	NAME	WATER PUMP OIL SEAL DRIVER
NO.	SYM-9620000	NO.	SYM-9100100	NO.	SYM-9120500-H9A

19. SPECIAL TOOLS



10		11		12	
					
NAME	WATER PUMP MECHANICL SEAL DRIVER	NAME	AC.G. FLYWHEEL PULLER	NAME	OIL SEAL DRIVER
NO.	SYM-1721700-H9A	NO.	SYM-3110A00	NO.	SYM-9125500
13		14		15	
					
NAME	OIL SEAL DRIVER	NAME	OIL SEAL DRIVER	NAME	UNIVERSAL HOLDER
NO.	SYM-9121600	NO.	SYM-9120200	NO.	SYM-2210100
16		17		18	
					
NAME	CLUTCH NUT WRENCH	NAME	CLUTCH SPRING COMPRESSOR	NAME	TAPPET ADJUSTING WRENCH
NO.	SYM-9020200	NO.	SYM-2301000	NO.	SYM-9001200

19		20		21	
					
NAME	VALVE SPRING COMPRESSOR	NAME	VALVE COTTER REMOVE & ASSEMBLY TOOL	NAME	UNIVERSAL HOLDER
NO.	SYM-1471100	NO.	SYM-1471110/20	NO.	SYM-9001210
22		23		24	
		 (30mm)		 (22mm)	
NAME	RR CUSHION ADJUSTING WRENCH	NAME	CRANK CASE BUSH PULLER	NAME	CRANK CASE BUSH PULLER
NO.	SYM-5320000	NO.	SYM-1120310	NO.	SYM-1120320
25		26			
					
NAME	OUTER BEARING PULLER	NAME	INNER BEARING PULLER		
NO.	SYM-6204010	NO.	SYM-6204020		

How to use special tools:



R/L. CRANK CASE PISASS TOOL

Disassemble the crankcase



Install the left crank case bearing



Install the crankshaft



BEARING DRIVER

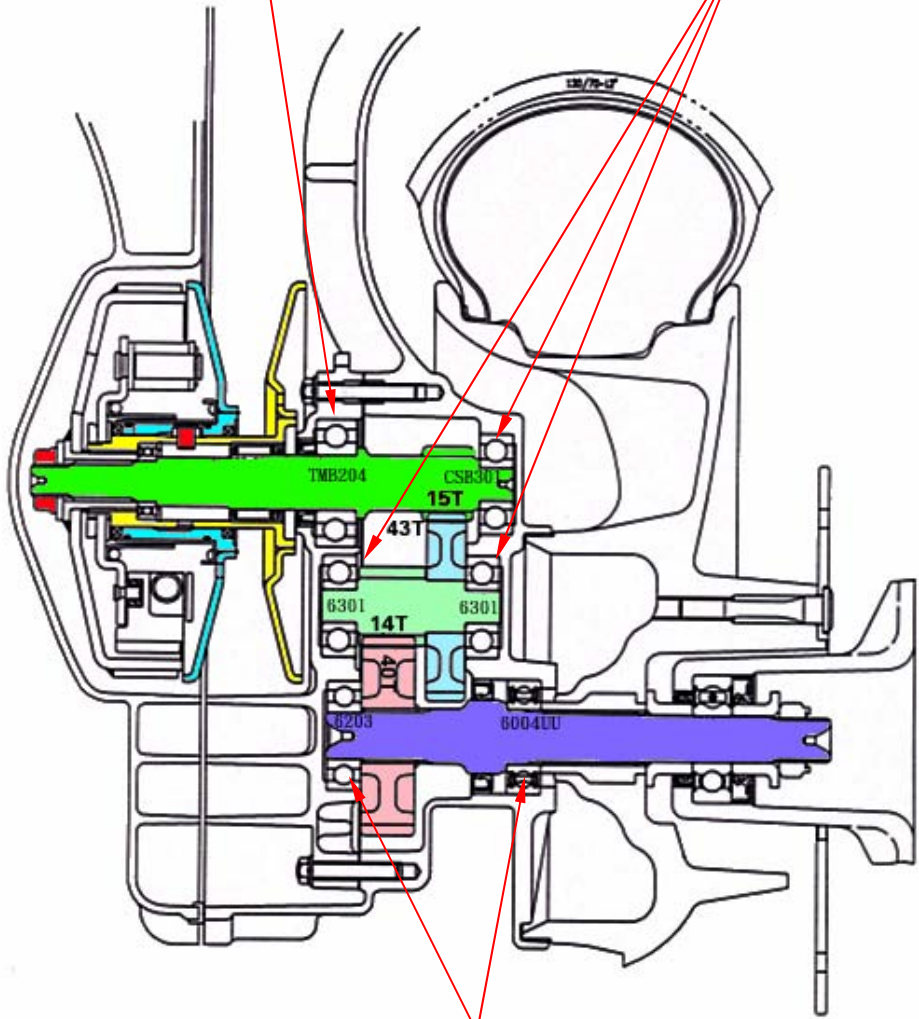



WATER PUMP BEARING DRIVER

BEARING (6901)



WATER PUMP OIL SEAL DRIVER

INNER OIL SEAL



MECHANICAL SEAL





(Seal from transmission side install)

CRANK CASE / TRANSMISSION OIL SEAL DRIVER

OIL SEAL (25*40*8)



OIL SEAL (20*32*6)



OIL SEAL (25*42*7)





AC.G. FLYWHEEL PULLER



VALVE COTTER REMOVE /
INSTALL DRIVER





OUTER BEARING PULLER



INNER BEARING PULLER





(30mm)

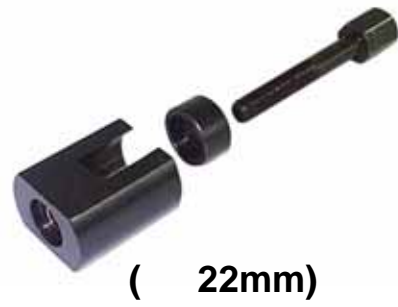

(22mm)

CRANK CASE BUSH PULLER / DRIVER

REMOVER



INSTALL



LA12W / LA15W SERIER WIRING DIAGRAM

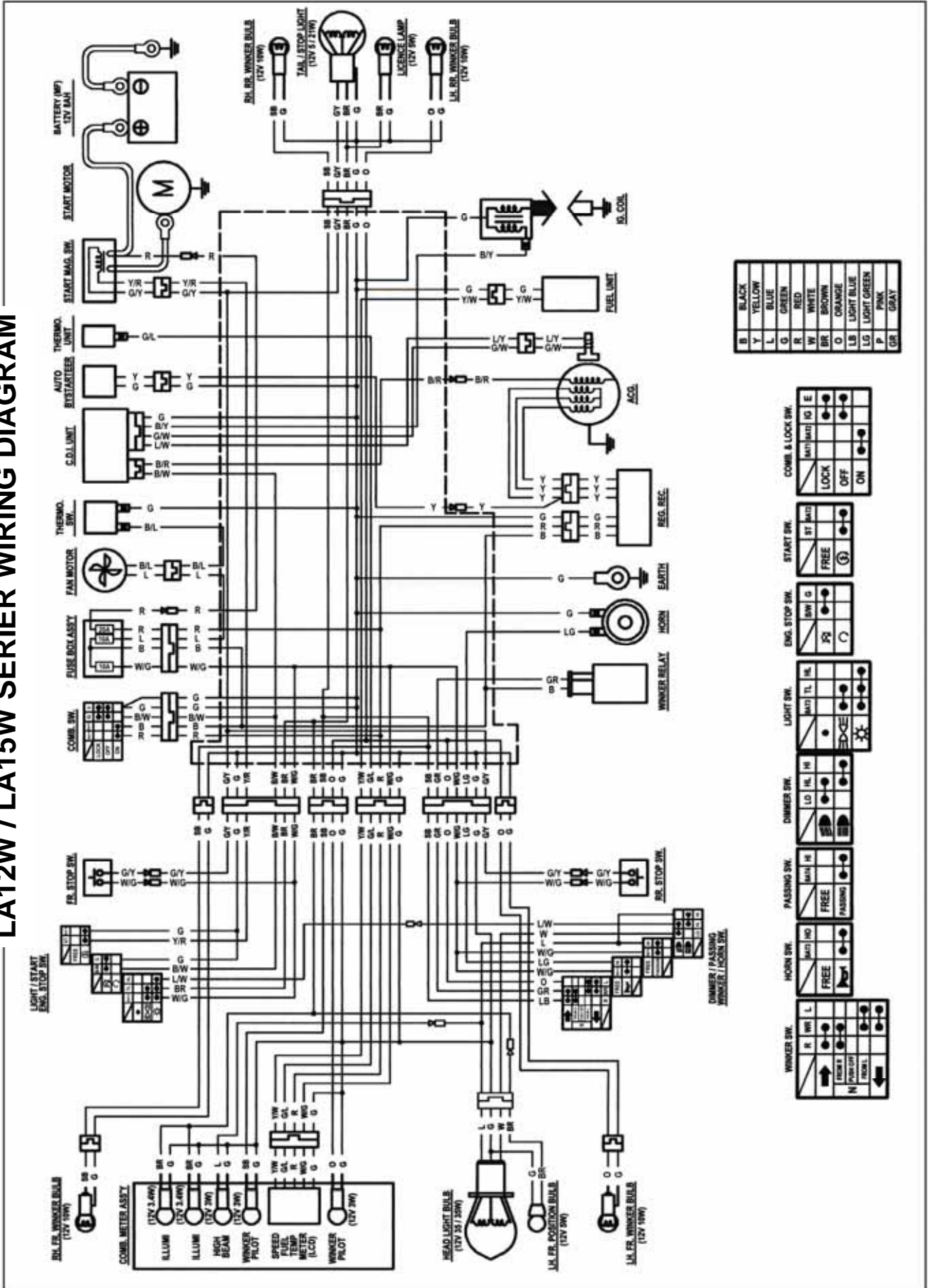

LA18W SERIER WIRING DIAGRAM

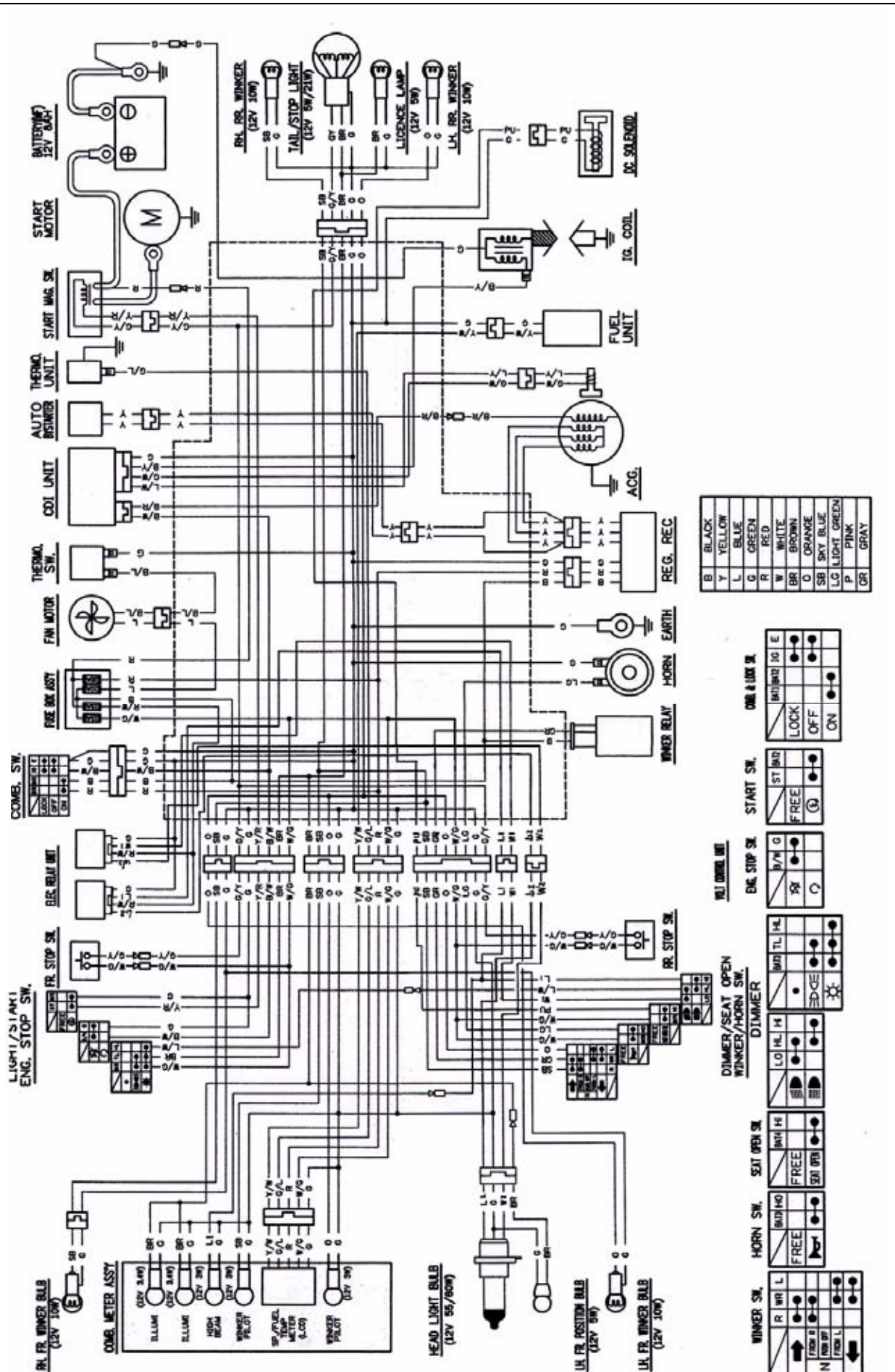

B	BLACK
Y	YELLOW
L	BLUE
G	GREEN
R	RED
W	WHITE
BR	BROWN
O	ORANGE
SB	SKY BLUE
L.C.	LIGHT GREEN
P	PINK
GR	GRAY

