



**SYM**



# ***Wolf SB 250 Ni***

## **SERVICE MANUAL**

**FOREWORD**

**CONTENTS**

**HOW TO USE THIS MANUAL**

**MECHANISM ILLUSTRATION**



This service manual contains the technical data of each component inspection and repair for the SANYANG PD25A series motorcycle. The manual is shown with illustrations and focused on “Service Procedures”, “Operation Key Points”, and “Inspection Adjustment” so that provides technician with service guidelines. Copyright reserved.

If the style and construction of the motorcycle, PD25A series motorcycle, are different from that of the photos, pictures shown in this manual, you should follow the actual vehicle layout. Specifications may be changed without notice.

**Service Department**  
**SANYANG INDUSTRY CO., LTD.**

---

## How to use this manual

---



This service manual describes basic information of individual parts and system inspection & service for SANYANG PD25A series motorcycle. In addition, please refer to the manual contents for detailed information for the model year.

The first chapter covers general information and trouble diagnosis.

The second chapter covers service maintenance information and special tools manual.

The third to the 9th chapters cover engine and driving systems.

The 10th chapter covers cooling systems.

The 11th to the 13th chapters contain the parts of vehicle frame.

The 14th chapter is electrical appliances.

The 15th chapter is emission control system.

The 16th chapter is electrical diagram.

Please see index of content for brief information and quick guide.

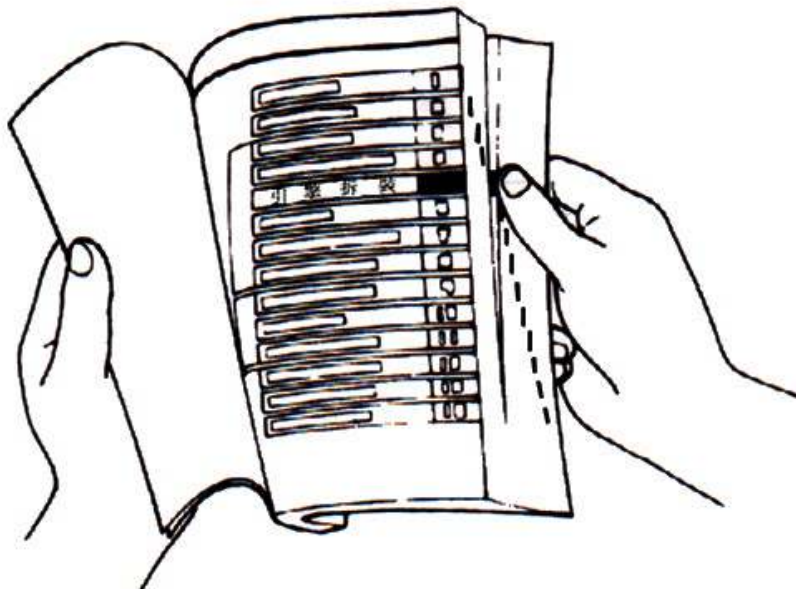

<b>Page</b>	<b>Content</b>	<b>Index</b>
1-1 ~ 1-19	General Information	<b>1</b>
2-1 ~ 2-16	Maintenance Information	<b>2</b>
3-1 ~ 3-45	Injection System	<b>3</b>
4-1 ~ 4-14	Lubrication / Clutch / Transmission	<b>4</b>
5-1 ~ 5-8	AC Generator / Starting Clutch	<b>5</b>
6-1 ~ 6-8	Engine Removal	<b>6</b>
7-1 ~ 7-16	Cylinder Head / Valve	<b>7</b>
8-1 ~ 8-10	Cylinder / Piston	<b>8</b>
9-1 ~ 9-14	Crankshaft / Crankcase / Shifting Gear	<b>9</b>
10-1 ~ 10-14	Cooling System	<b>10</b>
11-1 ~ 11-10	Brake System	<b>11</b>
12-1 ~ 12-14	Steering / Front Wheel / Front Fork	<b>12</b>
13-1 ~ 13-12	Rear Wheel / Rear Cushion	<b>13</b>
14-1 ~ 14-26	Electrical System	<b>14</b>
15-1 ~ 15-10	Emission Control System	<b>15</b>
16-1 ~ 16-2	Wiring Diagram	<b>16</b>



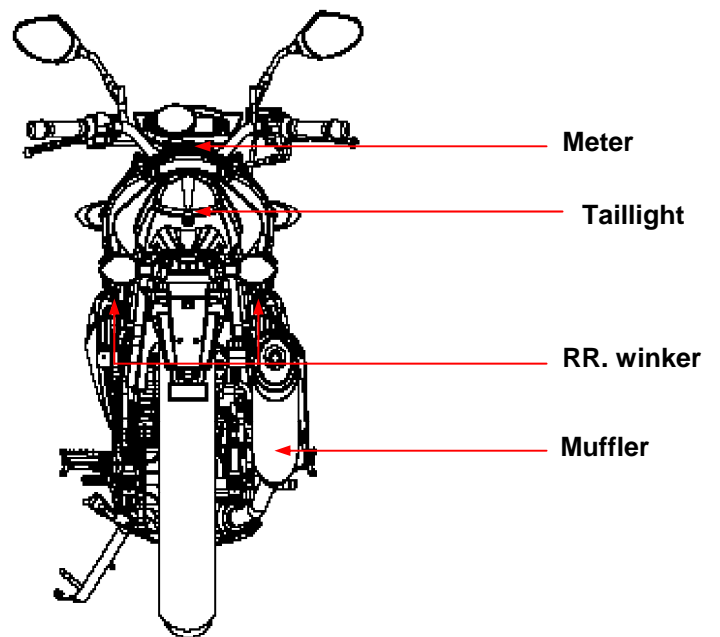
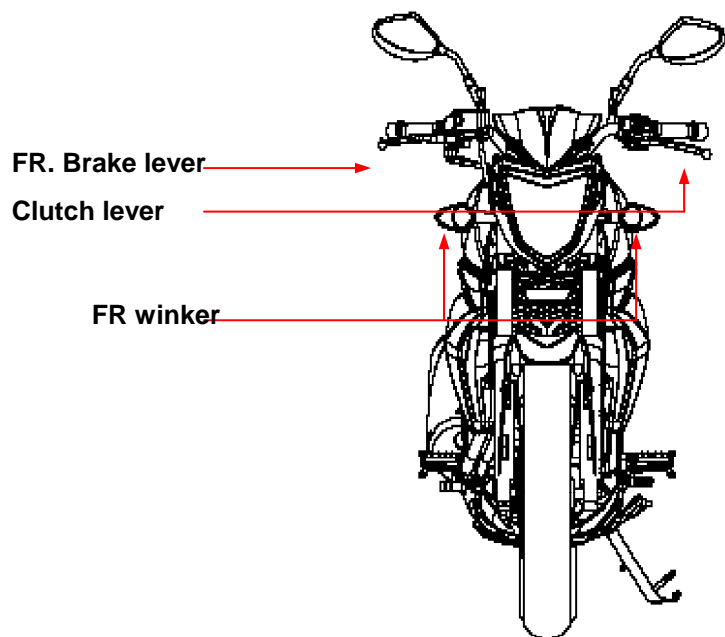
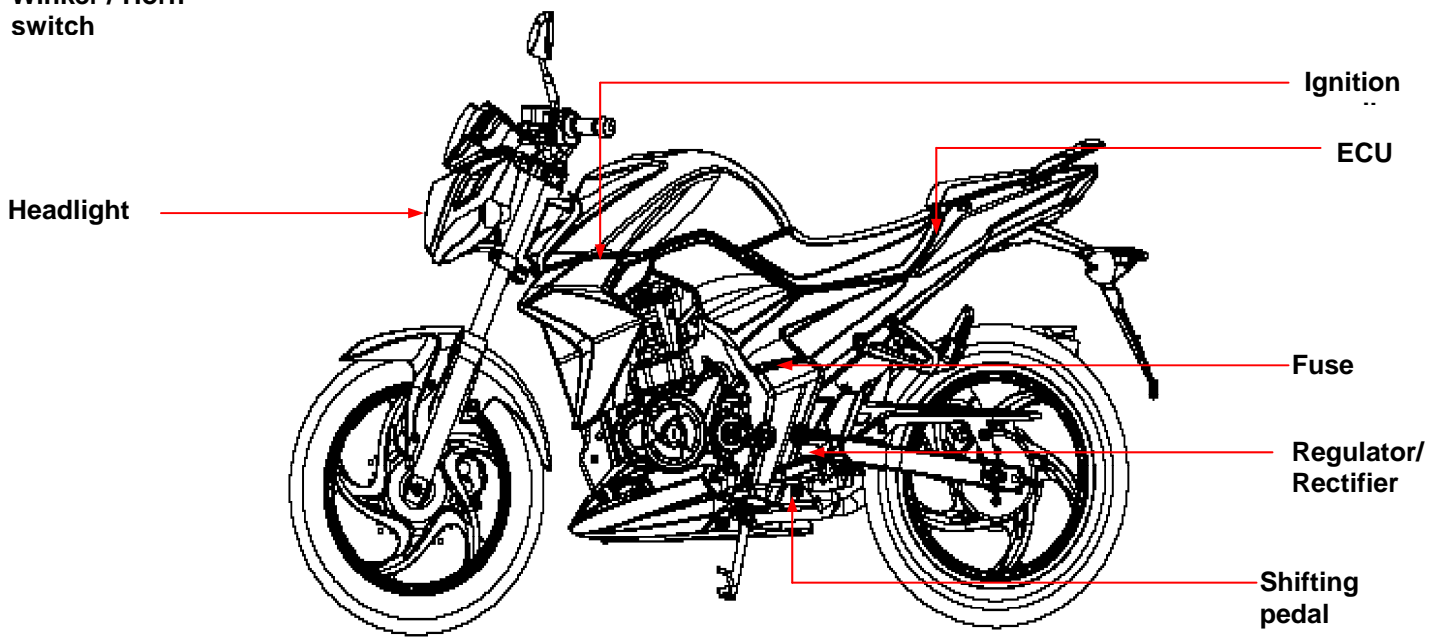
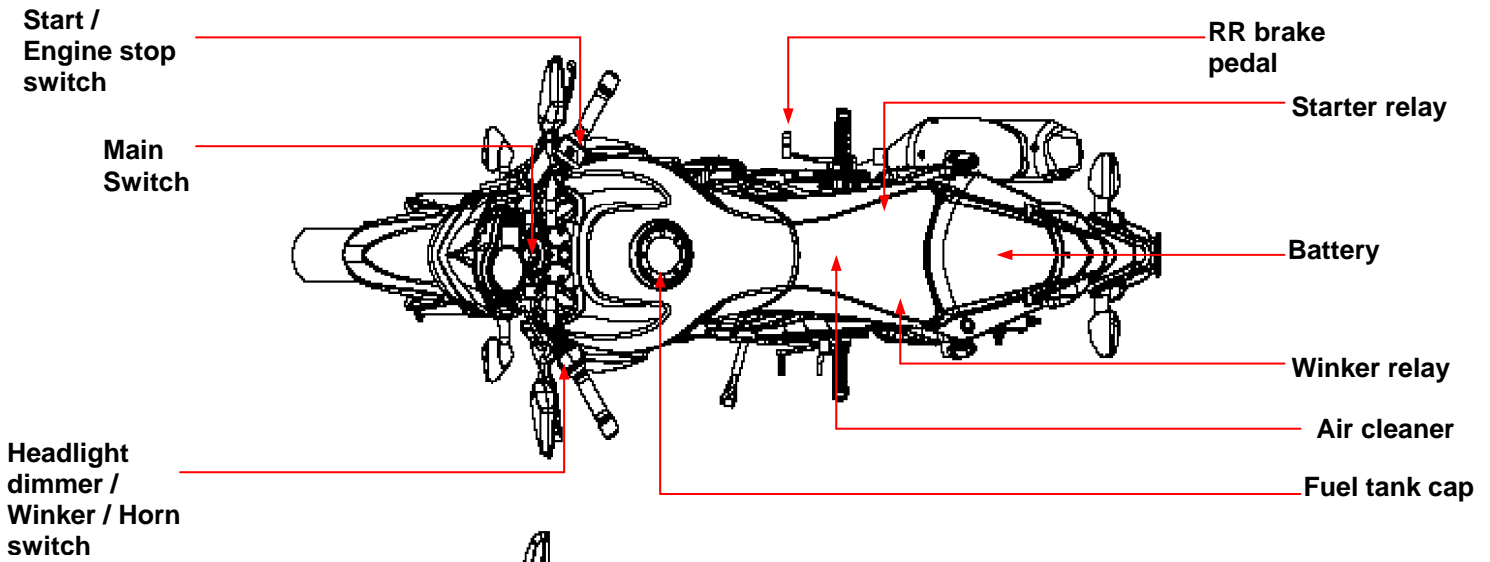











# Mechanism Illustration

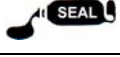

<b>Symbols and Marks ..... 1-1</b>	<b>Torque Values(Frame) ..... 1-11</b>
<b>General Safety ..... 1-2</b>	<b>Torque Values ..... 1-11</b>
<b>Service Precautions ..... 1-3</b>	<b>Troubleshooting ..... 1-12</b>
<b>Specifications ..... 1-9</b>	<b>Lubrication Points ..... 1-17</b>
<b>Torque Values(Engine) ..... 1-10</b>	

## Symbols and Marks

Symbols and marks are used in this manual to indicate what and where the special service are needed, in case supplemental information in procedures is needed for these symbols and marks, explanations will be added to the text instead of using the symbols or marks.

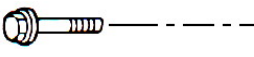
	Warning	Means that serious injury or even death may result if procedures are not followed.
	Caution	Means that equipment damages may result if procedures are not followed.
	Engine oil	Limits to use SAE 10W-30 API SG class oil. Warranty will not cover the damage that caused by not apply with the limited engine oil. (Recommended oil: <b>Bramax G-3 oil</b> )
	Grease	King Mate G-3 is recommended.
	Gear oil	King Mate gear oil serials are recommended. (Bramax HYPOID GEAR OIL # 140)
	Locking sealant	Apply sealant; medium strength sealant should be used unless otherwise specified.
	Oil seal	Apply with lubricant.
	Renew	Replace with a new part before installation.
	Brake fluid	Use recommended brake fluid DOT3 or WELLRUN brake fluid.
	Special tools	Special tools
	Correct	Meaning correct installation.
	Wrong	Meaning wrong installation.
	Indication	Indication of components.
	Directions	Indicates position and operation directions
		Components assembly directions each other.
		Indicates where the bolt installation direction, --- means that bolt goes through the component (invisibility).

## General Safety

### Carbon monoxide

If you must run your engine, ensure the place is well ventilated. Never run your engine in a closed area. Run your engine in an open area, if you have to run your engine in a closed area, be sure to use a ventilator.

#### Caution

- Exhaust contains toxic gas, which may cause one to lose consciousness and even result in death.

### Gasoline

Gasoline is a low ignition point and explosive material. Work in a well-ventilated place, no flame or spark allowed in the work place or where gasoline is being stored.

#### Caution

- Gasoline is highly flammable, and may explode under some conditions, keep it away from children.

### Used engine oil

#### Caution

Prolonged contact with used engine oil (or transmission oil) may cause skin cancer although it might not be verified.

- We recommend you to wash your hands with soap and water right after contacting. Keep the used oil beyond reach of children.

### Hot components

#### Caution

- Components of the engine and exhaust system can become extremely hot after engine running. They remain very hot even after the engine has been stopped for some time. When performing service work on these parts, wear insulated gloves and wait until the vehicle is cooling down.

### Battery

#### Caution

- Battery emits explosive gases; flame is strictly prohibited. Keep the place well ventilated when charging the battery.
- Battery contains sulfuric acid (electrolyte), which can cause serious burns, so be careful not to get the sulfuric acid on your eyes or skin. If you get battery acid on your skin, flush it off immediately with water. If you get battery acid in your eyes, flush it off immediately with plenty of water and then go to hospital to consult an ophthalmologist.
- If you swallow it by mistake, drink a lot of water or milk, and take some laxative such as vegetable oil and then go to see a doctor.
- Keep electrolyte beyond reach of children.

### Brake shoe

Do not use compressed air or a dry brush to clean components of the brake system; use a vacuum cleaner or the equivalent to avoid dust flying.

#### Caution

- Inhaling brake shoe or pad ash may cause disorders and cancer of the breathing system

### Brake fluid

#### Caution

Spilling brake fluid on painted, plastic, or rubber parts may cause damage to the parts. Place a clean towel on the above-mentioned parts for protection when servicing the brake system. Keep the brake fluid beyond reach of children.

## Service Precautions

- Always use with SANYANG genuine parts and recommended oils. Using non-genuine parts for SANYANG vehicle may damage it.

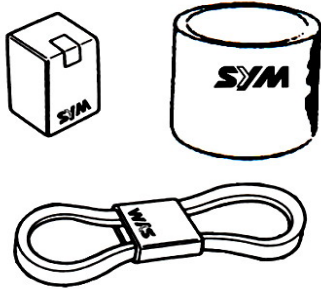

- Special tools are designed for removal and installation of components without damaging the part. Using wrong tools may result in damage.

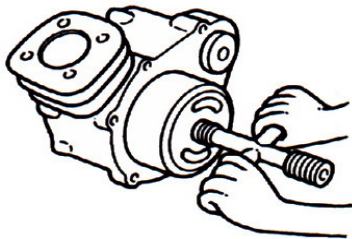

- When servicing this bike, use only metric tools, metric bolts, and nuts. Using wrong tools and fasteners may damage this vehicle.
- Clean the outside of the parts or the cover before removing it from the bike. Otherwise, dirt and deposit accumulated on the part's surface may fall into the engine, chassis, or brake system, and cause damage.
- Wash and clean parts with high ignition point solvent, and blow them dry with compressed air. Pay special attention to O-rings or oil seals because most cleaning agents have an adverse effect on them.

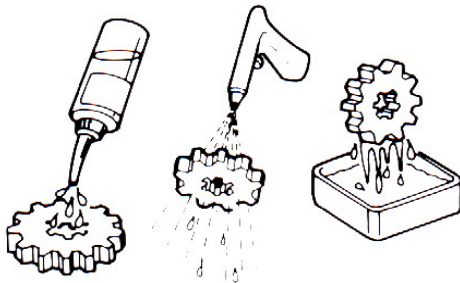

- Never bend or twist a control cable to prevent unsmooth control and premature worn out.

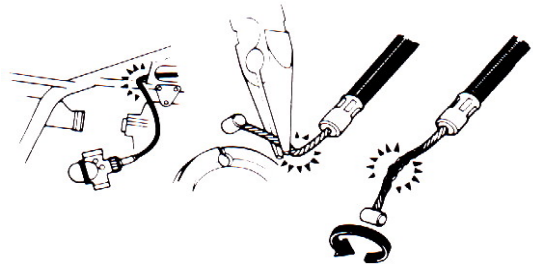

- Rubber parts may become deteriorated when old and easy to be damaged by solvent and oil. Check these parts before installation to make sure that they are in good condition, replace if necessary.
- When loosening a component, which has different sized fasteners, operate with a diagonal pattern and work from inside out. Loosen the small fasteners first. If the bigger ones are loosen first, small fasteners may receive too much stress.
- Store complex components such as transmission parts in the proper assemble order and tie them together with a wire for ease of installation later.

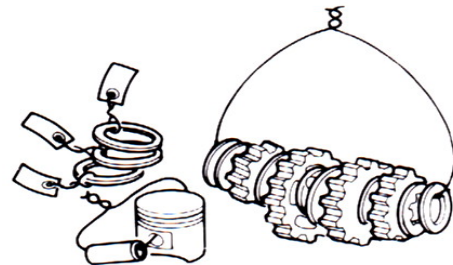

- Note the reassemble position of the important components before disassembling them to ensure they will be reassembled in correct dimensions (depth, distance or position).
- Components not to be reused should be replaced when disassembled including gaskets metal seal rings, O-rings, oil seals, snap rings, and split pins.

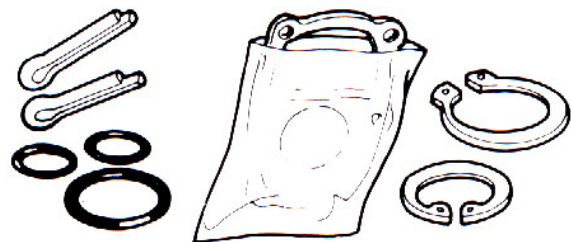



# 1. General Information



- The length of bolts and screws for assemblies, cover plates or boxes is different from one another; make sure they are correctly installed. In case of confusion, Insert the bolt into the hole to compare its length with other bolts, if its length outside the hole is the same with other bolts, it is a correct bolt. Bolts for the same assembly should have the same length.

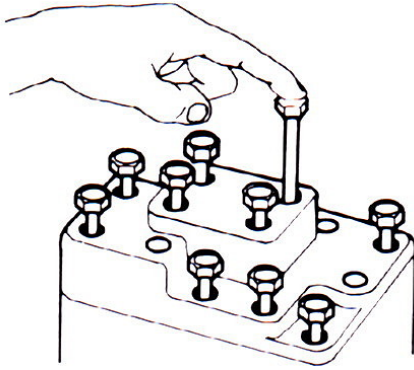

- Tighten assemblies with different dimension fasteners as follows: Tighten all the fasteners with fingers, then tighten the big ones with special tool first diagonally from inside toward outside, important components should be tightened 2 to 3 times with appropriate increments to avoid warp unless otherwise indicated. Bolts and fasteners should be kept clean and dry. Do not apply oil to the threads.

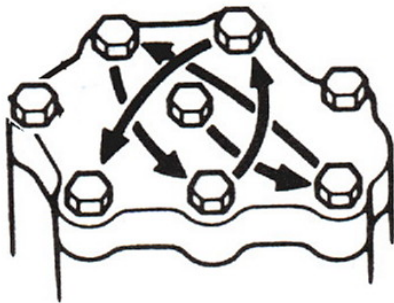

- When installing oil seal, fill the groove with grease, install the oil seal with the name of the manufacturer facing outside, and check the shaft on which the oil seal is to be installed for smoothness and for burrs that may damage the oil seal.

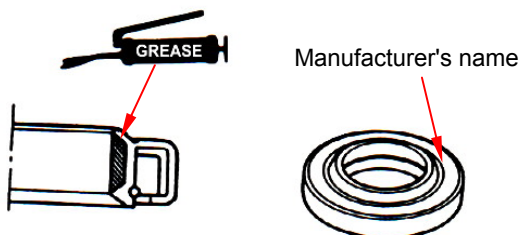

- Remove residues of the old gasket or sealant before reinstallation, grind with a grindstone if the contact surface has any damage.



- The ends of rubber hoses (for fuel, vacuum, or coolant) should be pushed as far as they can go to their connections so that there is enough room below the enlarged ends for tightening the clamps.

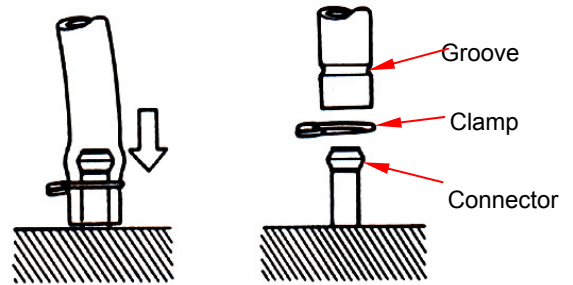

- Rubber and plastic boots should be properly reinstalled to the original correct positions as designed

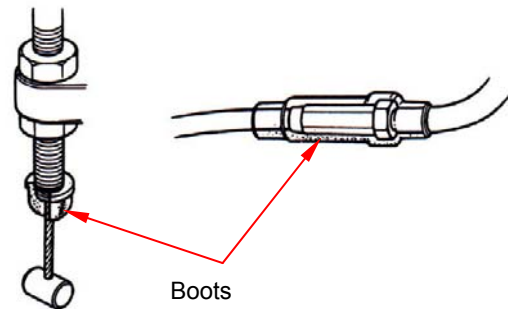

- The tool should be pressed against two (inner and outer) bearing races when removing a ball bearing. Damage may result if the tool is pressed against only one race (either inner race or outer race). In this case, the bearing should be replaced. To avoid damaging the bearing, use equal force on both races.

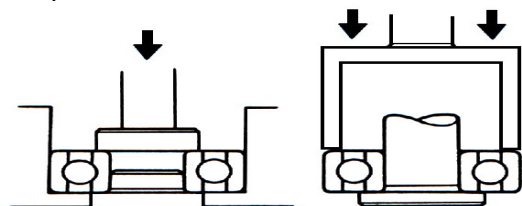

Both of these examples can result in bearing damage.

- Lubricate the rotation face with specified lubricant on the lubrication points before assembling.

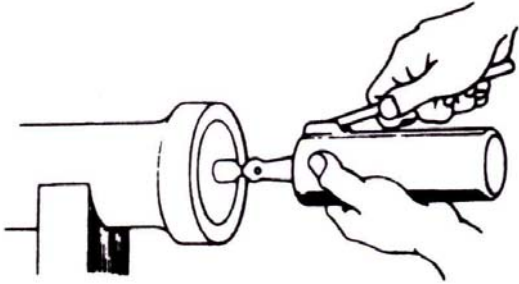

- Check if positions and operation of installed parts are correct and proper.

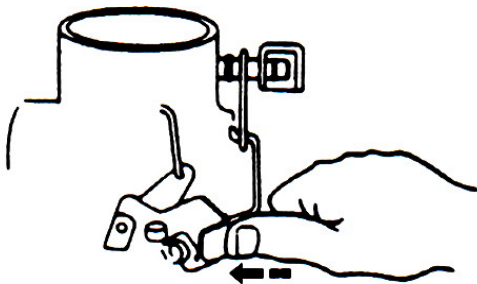

- Make sure service safety each other when conducting by two persons.

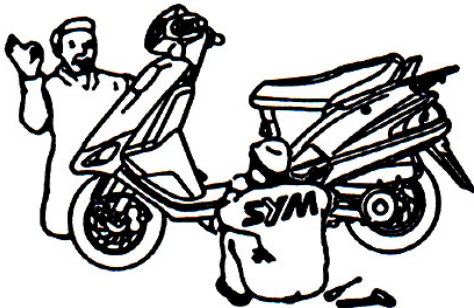

- Note that do not let parts fall down.



- Before battery removal operation, you have to remove the battery negative (-) cable first. Avoid using tools like open-end wrench, which may contact with body or create spark.

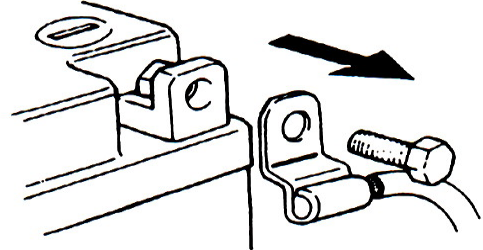

- After service completed, make sure all connection points is secured. Battery positive (+) cable should be connected firstly. And the two posts of battery have to be greased after connected the cables.

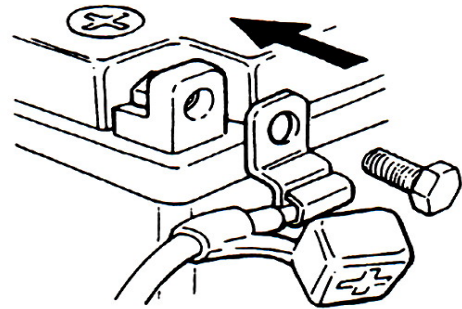

- Make sure that the battery post caps are located properly after the battery posts had been serviced.

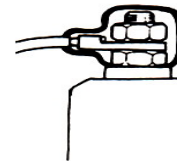

- If a fuse is burned, it has to find out the cause and solved it. And then replace with specified capacity fuse.

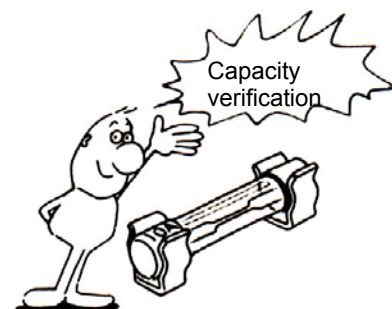

# 1. General Information



- When separating a connector, its locker has to be unlocked first. Then, conduct the service operation.

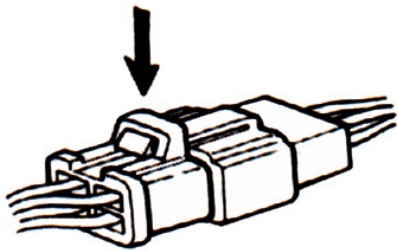

- Do not pull the wires as removing a connector or wires. Hold the connector body.



- Make sure if the connector pins are bent, extruded or loosened.

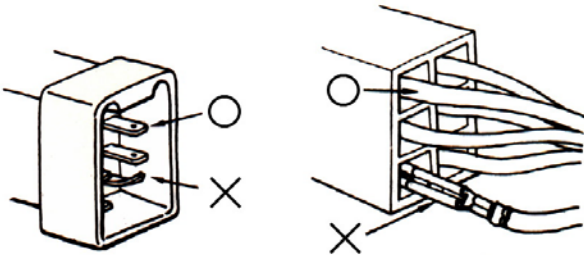

- Insert the connector completely.
- If there are two lockers on two connector sides, make sure the lockers are locked in properly.
- Check if any wire loose.

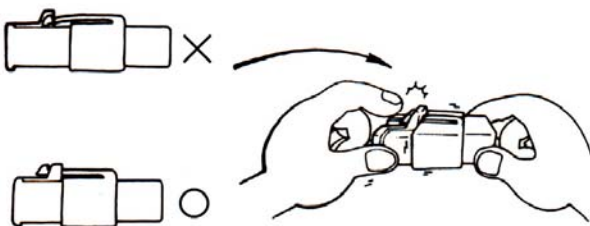

- Check if the connector is covered by the twin connector boot completely and secured properly.

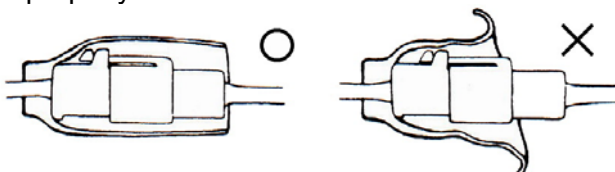

- Before connecting terminals, check if the boot is cracked or the terminal is loose.

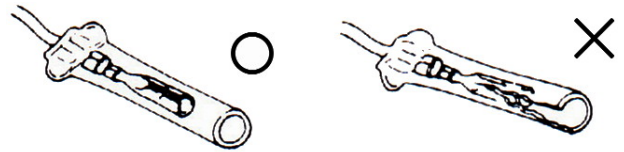

- Insert the terminal completely.
- Check if the boot covers the terminal.
- Do not let boot open facing up.

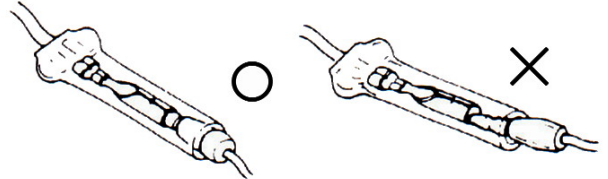

- Secure wires and wire harnesses to the frame with respective wire bands at the designated locations. Tighten the bands so that only the insulated surfaces contact the wires or wire harnesses

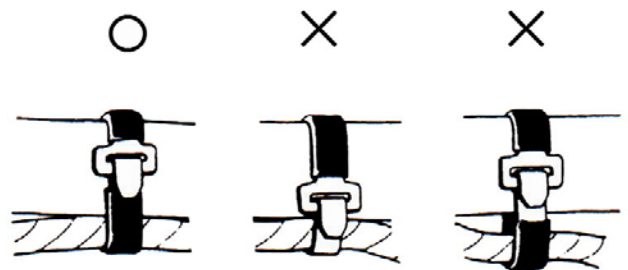

- Wire band and wire harness have to be clamped secured properly.

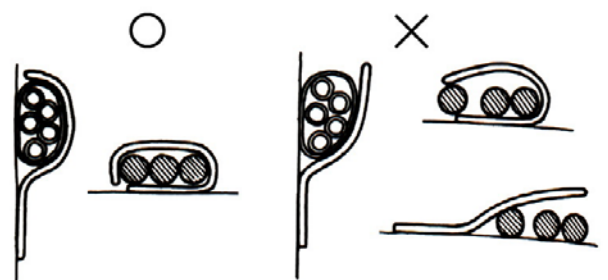

- Do not squeeze wires against the weld or its clamp.



- Do not let the wire harness contact with rotating, moving or vibrating components when routing the harness.

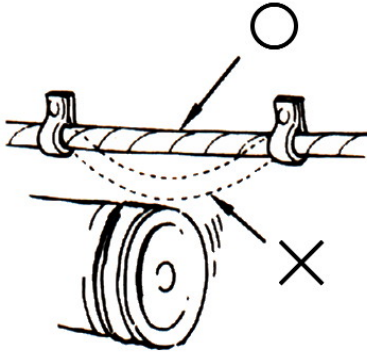

- Keep wire harnesses far away from the hot parts.

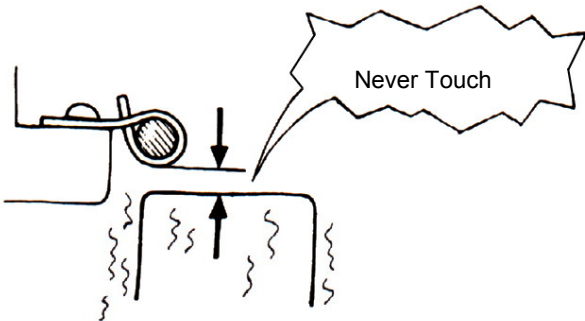

- Avoid wire harnesses from sharp edges or corners, and also avoid the jutting-out ends of bolts and screws.

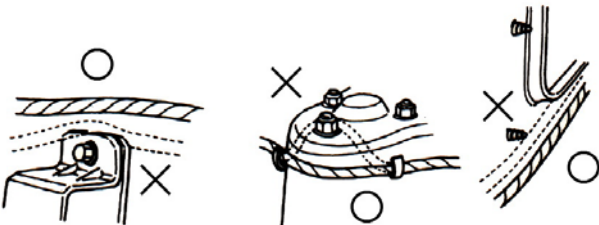

- Route harnesses so that they neither pull too tight nor have excessive slack.

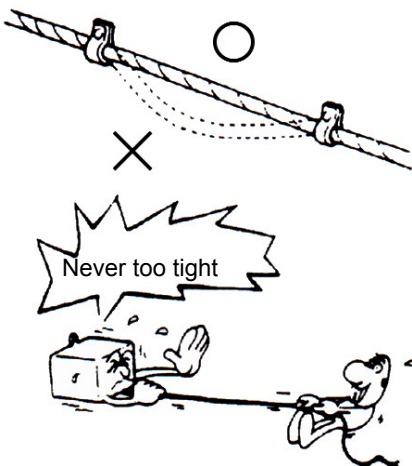

- Protect wires or wire harnesses with electrical tape or tube if they contact a sharp edge or corner. Thoroughly clean the surface where tape is to be applied.

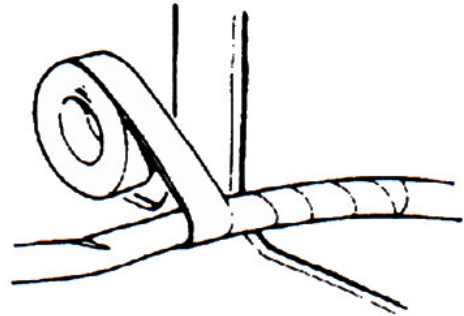

- Secure the rubber boot firmly as applying it on wire harness.

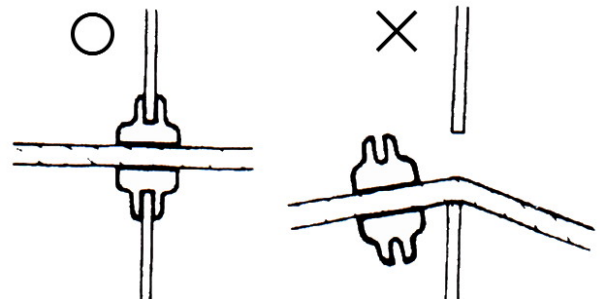

- Never use wires or harnesses which insulation has broken. Wrap electrical tape around the damaged parts or replace them.

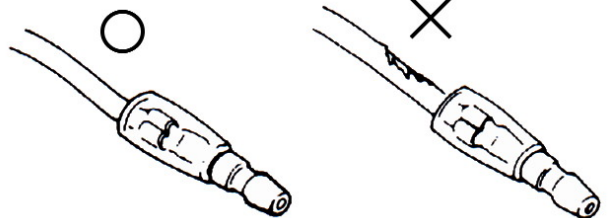

- Never clamp or squeeze the wire harness when installing other components.



- Do not let the wire harness be twisted when installation.

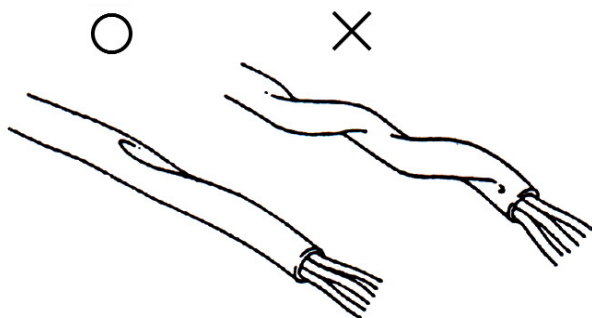

- Use sand paper to clean connector pins/terminals if rust is found. And then continue the connection operation.



- Wire harnesses routed along the handlebar should not be pulled too tight or have excessive slack, use rubber covering against adjacent or surrounding parts in all steering perimeters.

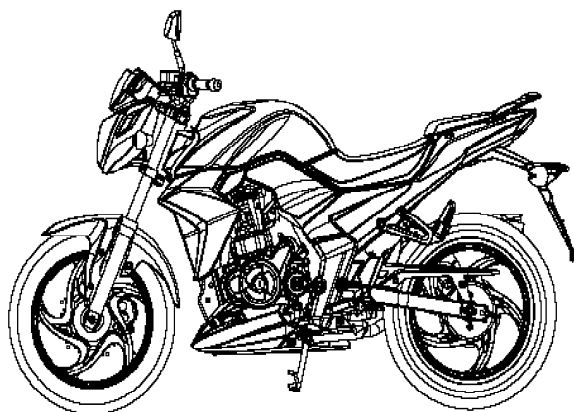

- Before operating a test instrument, the operator should read the operation manual of the instrument, and then conducts test in accordance with the instruction.

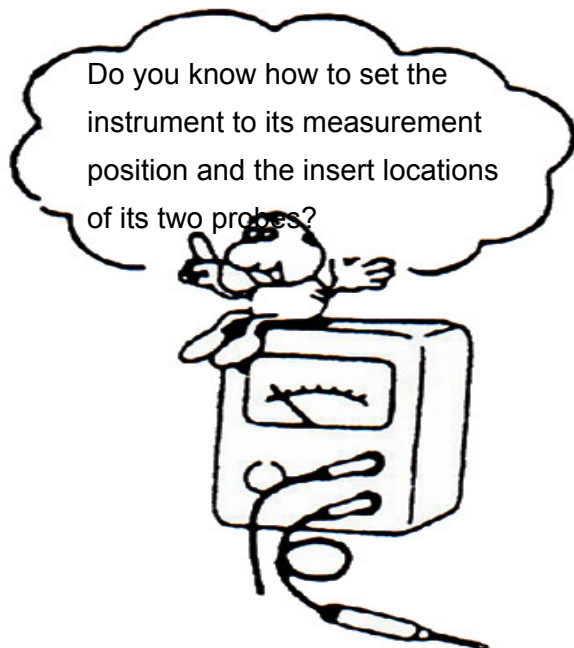

## Specifications

Maker		SYM		Model		PD25A1	
Dimension	Overall Length		2005 mm		Suspension System	Front	TELESCOPIC FORK
	Overall Width		790 mm			Rear	UNIT SWING
	Overall Height		1050 mm		Tire Specifications	Front	110/70-17 54H
	Wheel Base		1320 mm			Rear	140/70-17 66H
Weight	Curb Weight	Front	82 kg		Brake System	Front	DISK (ø 288 mm)
		Rear	91 kg			Rear	DISK (ø 222 mm)
		Total	173 kg				
	Passengers/Weight		Two / 150 kg		Performance	Max. Speed	> 140 km/hr
	Total Weight	Front	112 kg			Climb Ability	< 28°
		Rear	211 kg		Primary Reduction	2.826 (65/23T)	
		Total	323 kg		Final Reduction	2.69 (35/13T)	
Type/ Cooling System		Water-cooled 4-stroke gasoline engine		Reduction	Clutch	Wet multi-plate	
Installation and arrangement		Vertical, below center, incline 15°			Transmission	6 speed, circulated	
Fuel Used		Above 92 unleaded		Speedometer		0 ~ 199 km/hr	
Fuel supply		injection		Horn		1	
Engine	Cylinder	Bore	ø 71.0 mm		Muffler		Expansion & Pulse Type
		Stroke	63.0 mm		Exhaust Pipe Position and Direction		Right side and Backward
		Number/Arrangement	Single Cylinder		Lubrication System		Forced / Wet sump
	Displacement		249.4 cc		Exhaust Concentration	Solid Particulate	-
	Compression Ratio		10.5 : 1			CO	< 3.0 %
	Max. HP		25 ps / 7500 rpm			HC	< 1600 PPM
	Max. Torque		2.35 kg-m / 6000 rpm		E.E.C.		√
	Ignition		Full transistor Ignition		P.C.V.		√
	Starting System		Electrical starter		Catalytic reaction control system		√

# 1. General Information



## Torque Values (Engine)

Item	Q't	Thread Dia. (mm)	Torque Value(kgf-m)	Remarks
Cylinder stud bolt	4	10	1.0~1.4	
Cylinder head nut	4	10	3.6~4.0	
Cylinder head right bolt	2	6	1.0~1.4	
Cylinder head side cover bolt	3	6	1.0~1.4	
Cylinder head cover bolt	4	6	0.8~1.2	
Cylinder head stud bolt (inlet)	2	6	1.0~1.4	
Cylinder head stud bolt (EX.)	2	8	2.4~3.0	
Air inject pipe bolt	4	6	1.0~1.4	
Tappet adjustment screw nut	4	5	0.7~1.1	Lubricate with oil
Spark plug	1	10	1.0~1.2	
Camshaft gear fix bolt	2	6	1.0~1.4	
Camshaft setting plate bolt	1	6	0.8~1.2	
Cam chain tensioning bolt	2	6	1.0~1.4	
Throttle fix nut	2	6	0.8~1.2	
Engine oil draining bolt	1	12	3.5~4.5	
Engine oil strainer cap	1	30	1.3~1.7	
Flywheel nut	1	14	8.5~10.5	
R. crankcase cover bolt	12	6	0.8~1.2	
L. crankcase cover bolt	11	6	0.8~1.2	
L. crankcase rear cover bolt	2	6	0.8~1.2	
Oil pump screw	2	6	0.7~1.1	
Oil pump cover bolt	2	6	0.8~1.2	
Water pump impeller	1	7	1.0~1.4	
Water pump cover bolt	4	6	0.8~1.2	
Crankcase bolt	11	6	0.8~1.2	
Oil strainer cover bolt	2	6	0.8~1.2	
Balancing shaft drive gear bolt	4	6	0.8~1.2	
Primary drive gear nut	1	16	8.5~10.5	
Balancing shaft fix nut	1	14	8.5~10.5	
Clutch lifter plate bolt	6	6	1.0~1.4	
Clutch fix nut	1	16	8.5~10.5	
ACG fix bolt	3	6	0.8~1.4	
Drive gear bolt	2	6	0.8~1.2	

The torque values listed are important tightening torque values. Please see standard values for those not listed in the table.

## Torque Values (Frame)

Item	Q'ty	Thread Dia. (mm)	Torque Value (Kg-m)	Remarks
Mounting bolt for steering handle post	4	8	1.0~1.4	
Lock nut for steering stem	1	22	6.0~8.0	
Steering top cone race	1	22	0.15~0.25	
Front wheel axle nut	1	12	6.0~8.0	
Rear wheel axle nut	1	14	10.0~12.0	
Rear drive sprocket nut	4	8	2.7~3.0	
Front cushion mounting bolt	4	8	3.0~3.5	
Rear cushion upper connection bolt	1	10	3.5~4.5	
Rear cushion lower connection bolt	1	10	3.5~4.5	
Brake lever bolt	2	6	0.8~1.2	
Brake hose bolt	4	10	3.0~4.0	
Brake air-bleeding valve	2	6	0.8~1.0	
Front brake disc mounting bolt	3	6	3.7~4.3	
Rear brake disc mounting bolt	2	8	2.4~3.0	
Gear change bolt	1	6	0.8~1.2	
Brake clipper mounting bolt	2	6	1.5~2.0	
Engine suspension nut	2	8	2.4~3.0	upper part of engine & frame
Engine assembly nut	2	8	3.0~4.0	engine front part & engine hanger
Engine assembly nut	1	10	4.5~5.5	engine rear part & frame
Special Bolt	8	8	1.5~2.5	
Swing arm pivot nut	1	10	10.0~12.0	
Muffler mounting nut	2	8	1.0~1.2	
Muffler mounting bolt	2	8	3.2~3.8	

The torque values listed in above table are for more important tightening torque values. Please refer to standard values for those not listed in the table.

## Torque Values

Type	Tighten Torque	Type	Tighten Torque
5mm bolt, nut	0.45~0.60kgf-m	4mm screw	0.10~0.15kgf-m
6mm bolt, nut	0.80~1.20kgf-m	5mm screw	0.35~0.50kgf-m
8mm bolt, nut	1.80~2.50kgf-m	6mm screw, SH nut	0.70~1.10kgf-m
10mm bolt, nut	3.00~4.00kgf-m	6mm flange bolt, nut	1.00~1.40kgf-m
12mm bolt, nut	5.00~6.00kgf-m	8mm flange bolt, nut	2.40~3.00kgf-m
3mmscrew	0.05~0.08kgf-m	10mm flange bolt, nut	3.50~4.50kgf-m



## Troubleshooting

### A. Engine cannot be started or difficult to be started

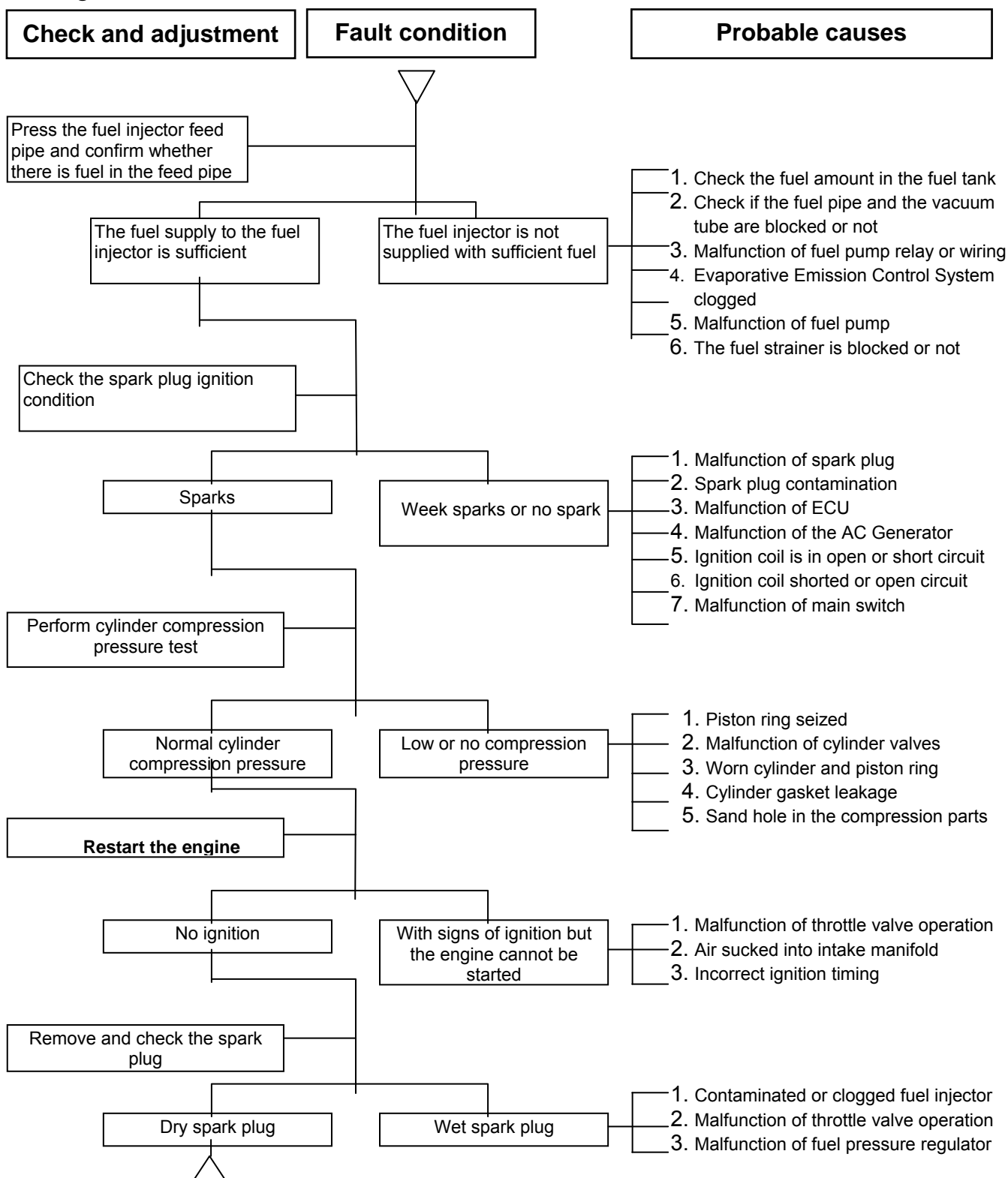

## B. Engine runs sluggish (Speed does not go up, lack of power)

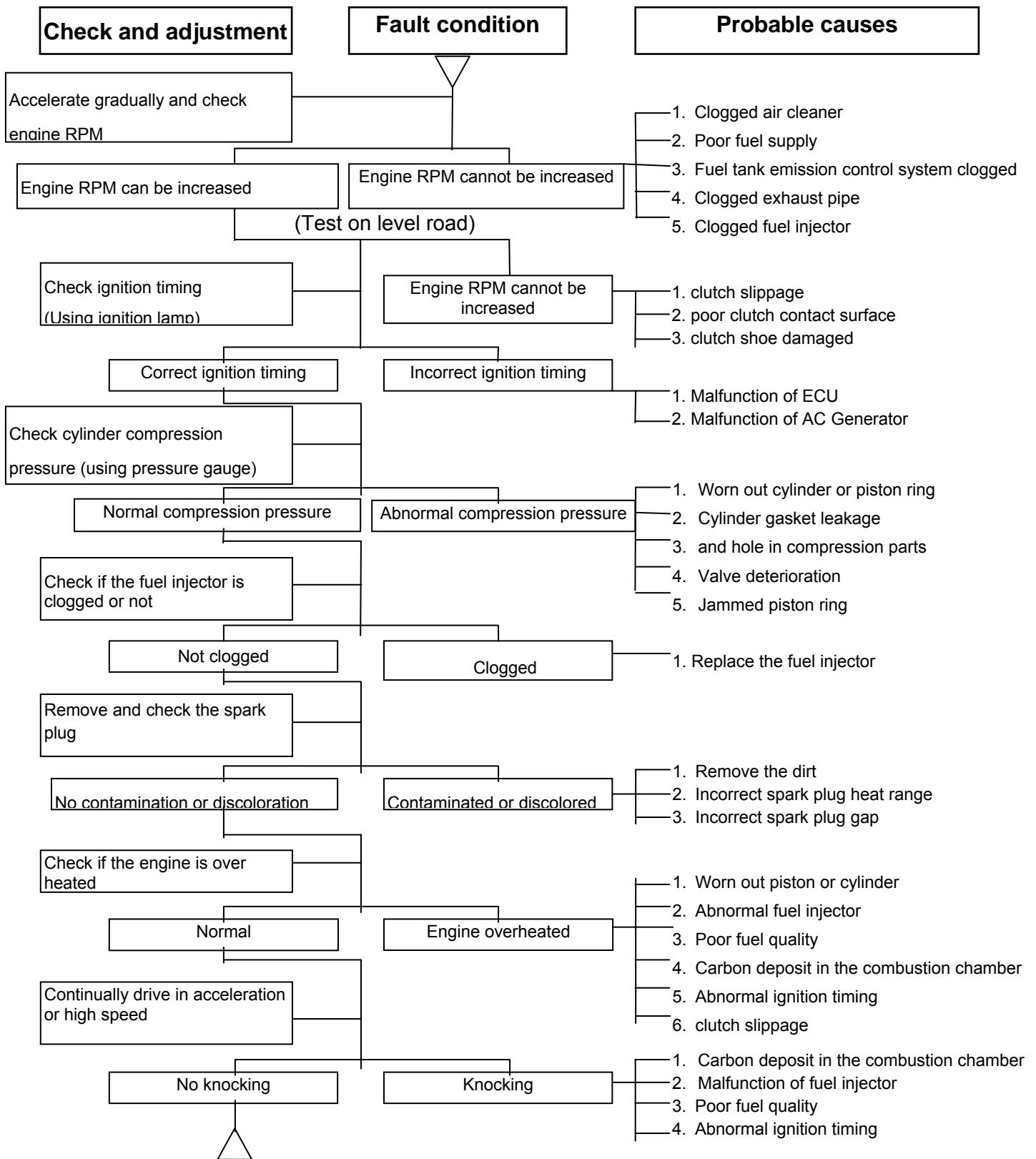

## C. Engine runs sluggish (especially in low speed and idling)

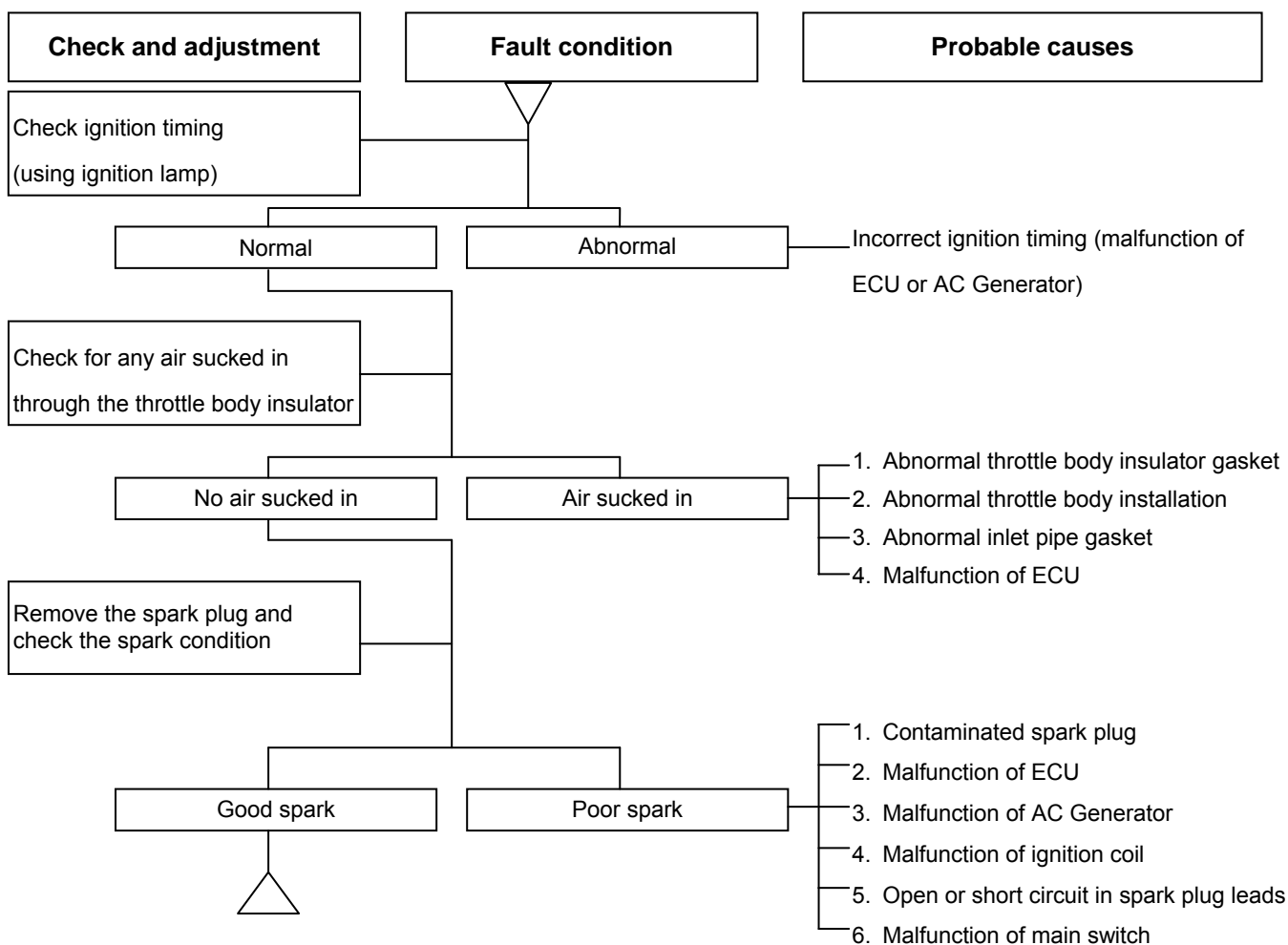

## D. Engine runs sluggish (High speed)

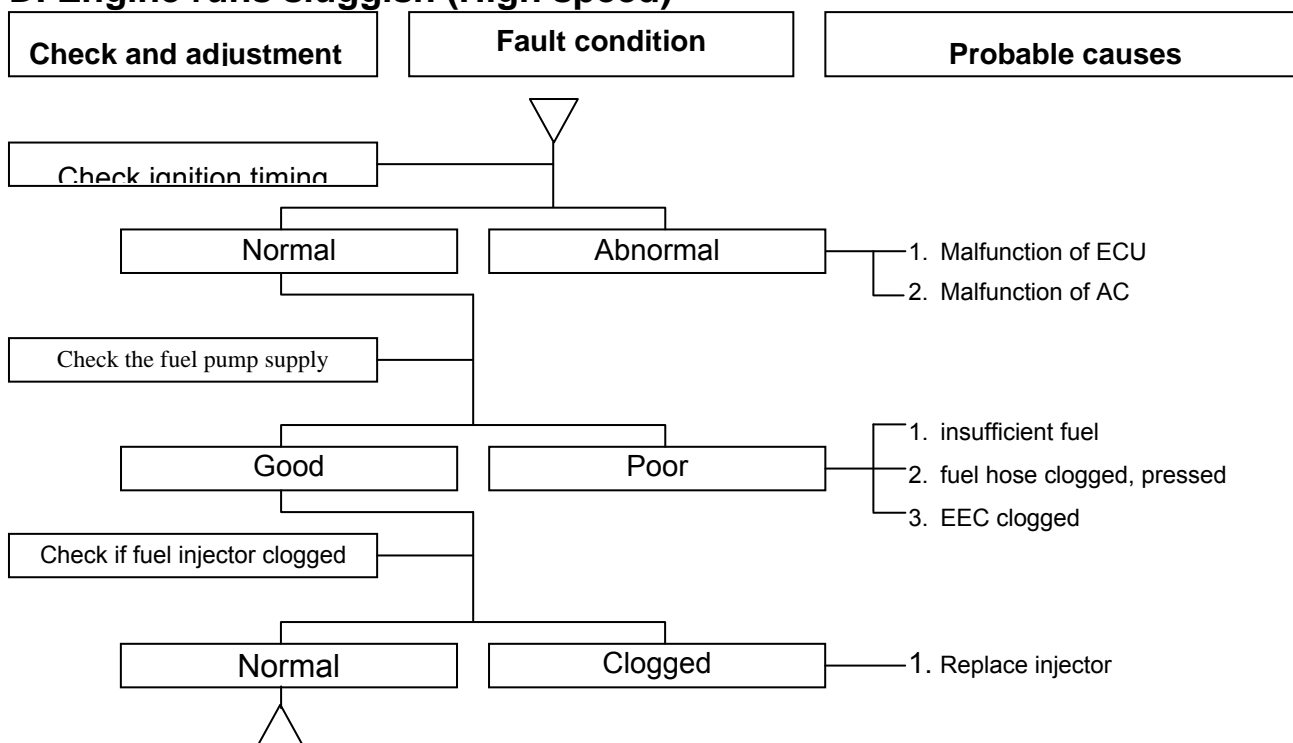

## E. Starter Motor Malfunction

### 1. Starter Motor doesn't rotate

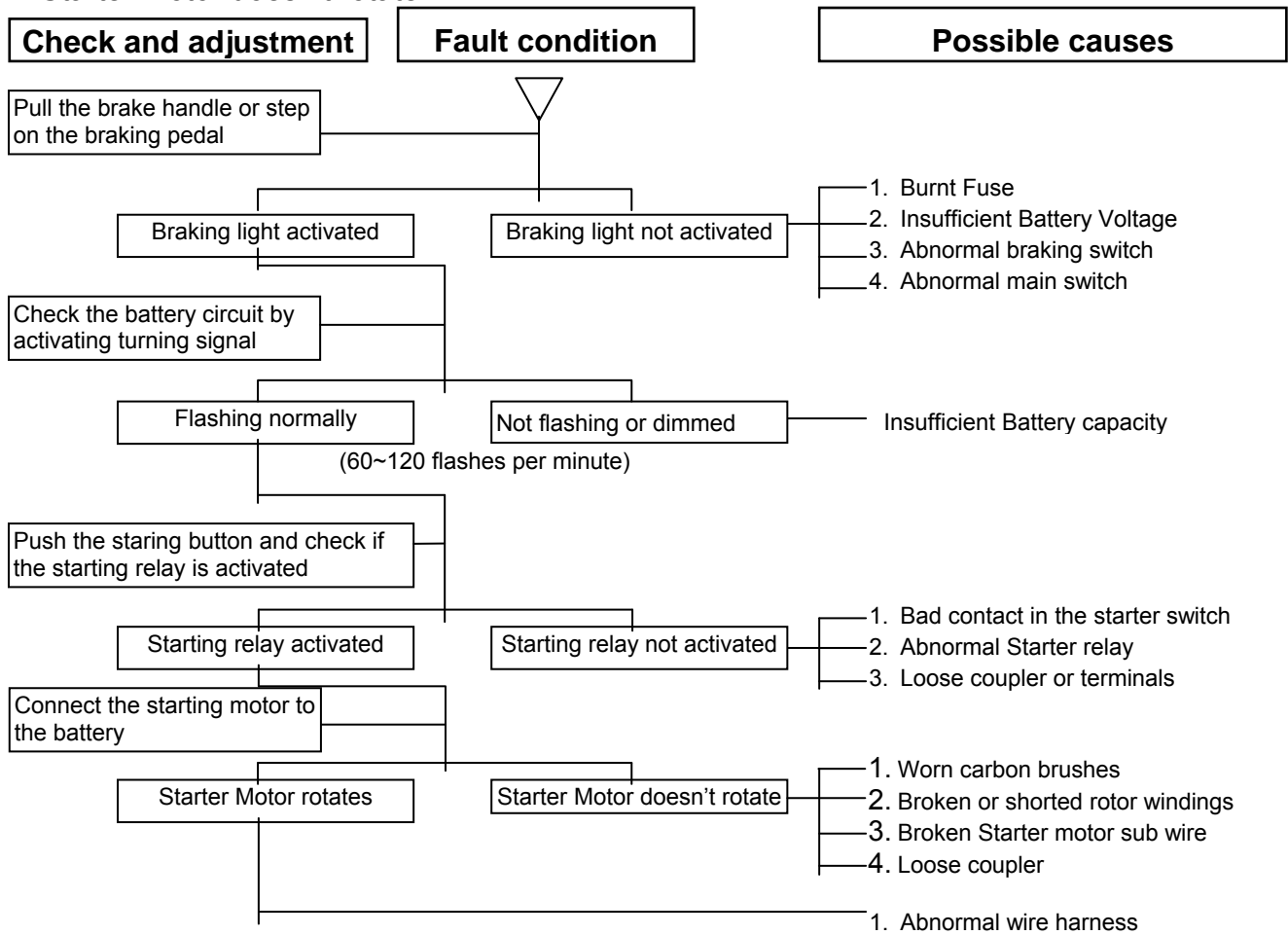

## 2. Starting Motor rotates slowly or spins without engagement with crankshaft

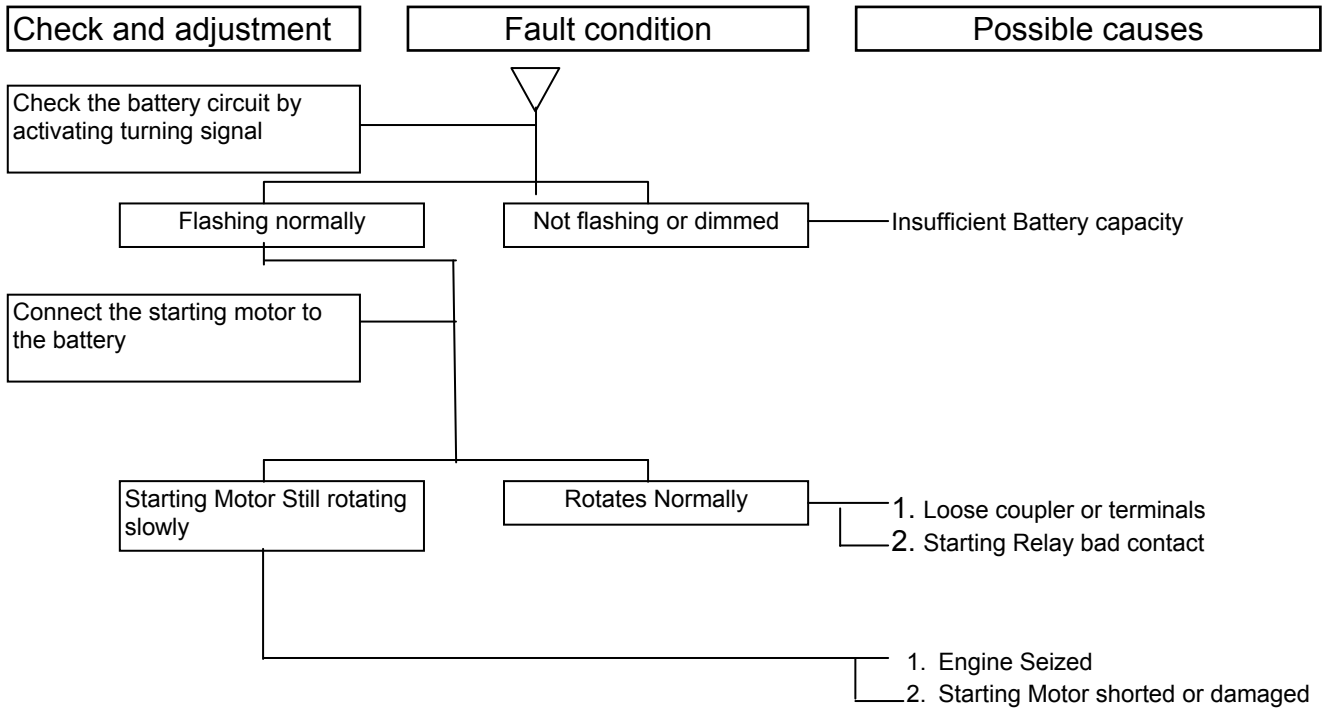

## 3. Starter motor won't stop rotating

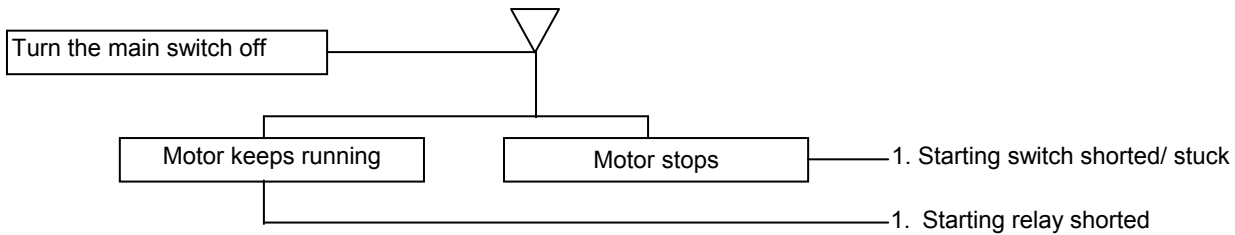

## F. Abnormal Engine Noise

Fault condition	Possible causes
Rocker arm noise	<ul style="list-style-type: none"> <li>1. Excessive valve clearance</li> <li>2. Worn rocker arm</li> <li>3. Worn camshaft</li> </ul>
Piston slapping	<ul style="list-style-type: none"> <li>1. Worn piston and cylinder</li> <li>2. Carbon deposit in the combustion chamber</li> <li>3. Worn piston pin or connecting rod lower end</li> </ul>
Cam chain noise	<ul style="list-style-type: none"> <li>1. Worn camshaft bearings</li> <li>2. Worn cam sprocket</li> <li>3. Loose or worn cam chain</li> </ul>
Clutch knocking	Excessive clutch plate clearance
Transmission gear noise	<ul style="list-style-type: none"> <li>1. Worn or deteriorated rear wheel damping rubber</li> <li>2. Gear surface worn</li> <li>3. Worn transmission gear set</li> </ul>

## Lubrication Points

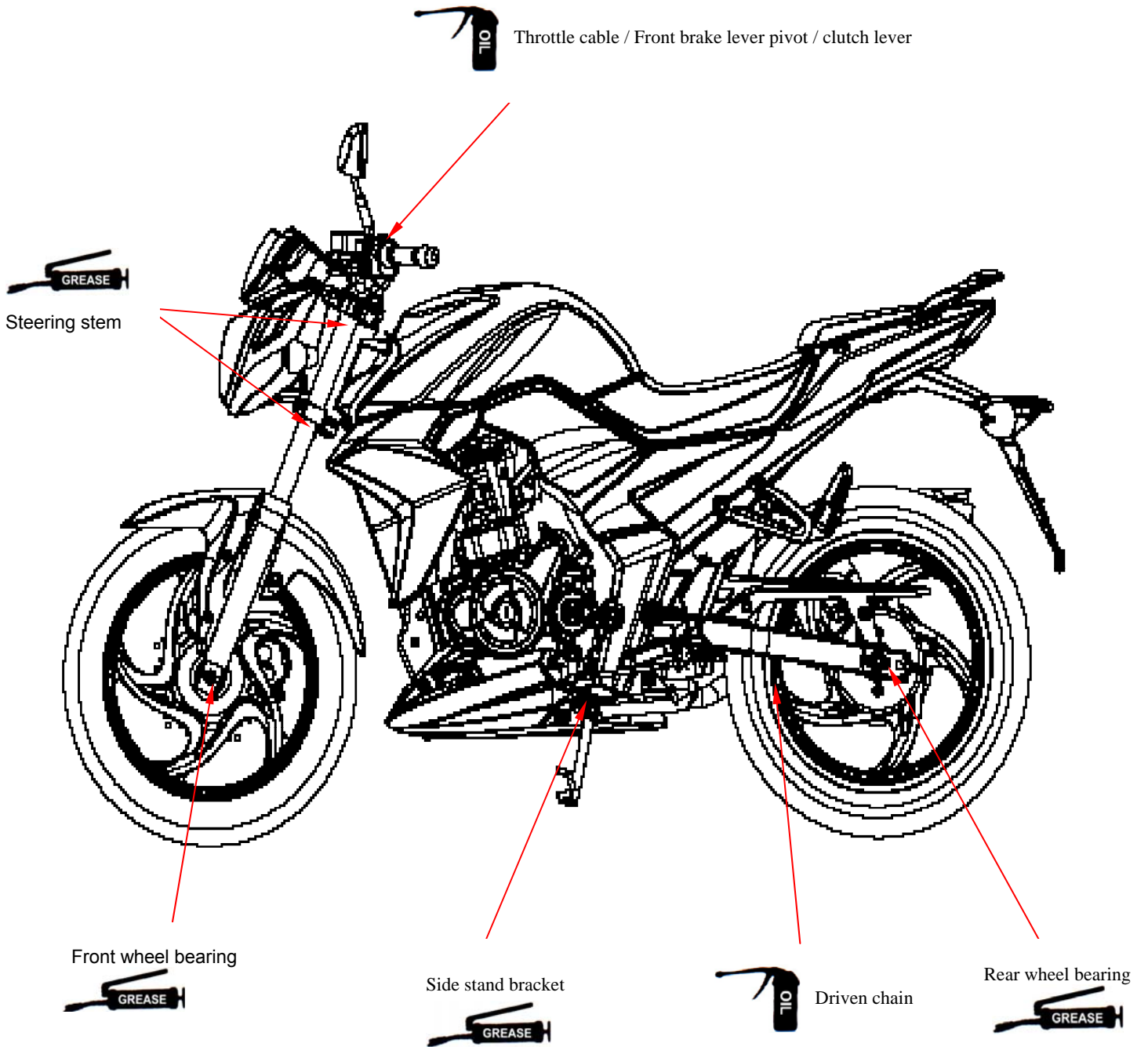

**NOTE:**

<b>Precautions in Operation</b> .....	<b>2-1</b>	<b>Steering Mechanism</b> .....	<b>2-8</b>
<b>Periodical Maintenance Schedule</b> .....	<b>2-2</b>	<b>Suspension System</b> .....	<b>2-9</b>
<b>Lubrication System</b> .....	<b>2-3</b>	<b>Disk Brake System</b> .....	<b>2-9</b>
<b>Cylinder Compression Test</b> .....	<b>2-4</b>	<b>Tire</b> .....	<b>2-11</b>
<b>Fuel System</b> .....	<b>2-5</b>	<b>Battery</b> .....	<b>2-12</b>
<b>Air Filter</b> .....	<b>2-5</b>	<b>Clutch Adjustment</b> .....	<b>2-12</b>
<b>Throttle Operation</b> .....	<b>2-6</b>	<b>Headlight Adjustment</b> .....	<b>2-13</b>
<b>Spark Plug</b> .....	<b>2-6</b>	<b>Brake Switch</b> .....	<b>2-13</b>
<b>PCV System</b> .....	<b>2-7</b>	<b>Nuts, Bolts Tightness</b> .....	<b>2-13</b>
<b>Valve Clearance Adjustment</b> .....	<b>2-7</b>	<b>Special Tools</b> .....	<b>2-14</b>
<b>Drive Chain Adjustment</b> .....	<b>2-8</b>		

### Precautions in Operation

#### Specifications

Fuel tank capacity	Capacity	14000 c.c.
	Reserve	700 c.c.
Engine Oil	Capacity	1700 c.c.
	Exchange	1500 c.c.
Throttle grip free play		2~6 mm
Spark plug		NGK CR8E
Spark plug gap		0.7~0.8 mm
Ignition timing		BTDC 13° / 1650 rpm
Idle speed		1650±100 rpm
Cylinder compression pressure		12±2 kgf/cm <sup>2</sup>
Valve clearance	In	0.10±0.02 mm
	Ex	0.15±0.02 mm
Tire size	Front	110/70-17 54H
	Rear	140/70-17 66H
Tire Pressure	Single ride	Front : 2.0 kg/cm <sup>2</sup> / Rear : 2.0 kg/cm <sup>2</sup>
	Tandem ride	Front : 2.0 kg/cm <sup>2</sup> / Rear : 2.25 kg/cm <sup>2</sup>
Battery	Type	GT12A-BS (12V 10Ah)



## 2. Maintenance Information



### Periodical Maintenance Schedule

NO	Items	Initial 300KM	1 month / every1000 KM	3 months / every3000 KM	6 months / every6000 KM	1year / every12000K M
1	☆Air filter element	I		C	C	R
2	☆Gasoline filter	I			I	R
3	☆Engine oil filter	R			R	
4	☆Engine oil strainer	C			C	C
5	☆Engine oil replacement	R	Change every 1000km			
6	Tire pressure	I	I			
7	Battery inspection	I	I			
8	Brake lever free play check	I	I			
9	Steering handle integrity check	I	I			
10	Shock absorber performance check	I		I		
11	Bolts tightening check	I	I			
12	Check the engine for oil leakage	I	I			
13	☆Spark plug inspection or replacement	I		I	R	
14	☆Change gear oil	R	Change every 5000km			
15	Lubrication of the whole bike				L	
16	Exhaust pipe	I	I			
17	☆Ignition timing	I	I			
18	☆Idle emission check	A	I	A		
19	☆Throttle operation	I		I		
20	☆Engine bolts torque	I		I		
21	☆Transmission / chain	I	I/L			R
22	☆Clutch free play inspection	I	I			
23	Light/electrical system//instrument readings	I	I			
24	Main stand/side stand spring	I			I	
25	Fuel lines	I		I		
26	Cam chain	I		I		
27	☆Valve clearance	I		A		
28	☆PCV	I		C		
29	☆Crankcase blow-by over-flow pipe	I	Drain every 2000km			
30	☆Evaporative control system			I		
31	☆Throttle body	A	I	A	C	
32	ECU input voltage				I	
33	EFi sensor coupler	I		I		

**Note: I-Inspection A-Adjust R-Replace C-Clean L-Lubricate**

Please have your periodical maintenance data recorded by your SYM Authorized Dealer to maintain the motorcycle in excellent condition. The above maintenance schedule is established by taking the monthly 1,000 kilometers as a reference. Whichever time or mileage comes first will be regarded as an index for maintenance.

**Remark : These marks “☆” in the schedule are emission control items. According to EPA regulations, these item checks must be performed periodically following the user manual instructions. It's prohibited to adjust or repair these emission control items by unauthorized people. Otherwise, SYM is no responsible.**

1. Clean or replace the air cleaner element more often when the motorcycle is operated on dusty roads or in the heavily polluted environment.
2. Maintenance should be performed more often if the motorcycle is frequently operated in high speed and after the motorcycle has accumulated a higher mileage.
3. Preventive maintenance
  - a. Ignition system - Perform maintenance or check when continuous abnormal ignition, misfire, after-burn, overheating occur.
  - b. Carbon deposit removal - Remove carbon deposits in cylinder head, piston heads, exhaust system when power is decreasing.
  - c. Replace worn out pistons, cylinder head.

### Lubrication System

#### Engine Oil quantity

##### Caution

- Turn off the engine; park the motorcycle on level surface with main stand.
- Run the engine for 3-5 minutes, check oil capacity after engine off for 3-5

Check oil quantity from inspection window, if oil level is near lower limit, fill in the recommended oil to upper limit.

#### Exchange engine oil

Remove the oil drain bolt under the crankcase to drain the engine oil. After completely drain the engine oil, clean the drain bolt and the washer. If the washer is deformed or cracked, please change a new one.

Engine oil drain bolt torque : **3.5~4.5kgf-m**

##### Caution

- Warm up the engine before draining oil; that will make engine oil easily and thoroughly drained.

Fill in the engine oil to the standard quantity.

Oil viscosity : SAE10W -30

#### Engine oil exchange volume

Full disassembly : 1700 c.c.

Regular exchange : 1500 c.c.

Run the engine for several minutes, check for oil leakage.

#### Engine oil strainer cleaning

Drain engine oil completely , remove oil strainer cap, spring, and strainer from left side of crankcase.

Clean oil strainer with solvent or compressed air.

Check if O-ring is deformed or damaged, replace if necessary.

Install strainer, spring, and oil strainer cap.

Torque value : **1.3~1.7kgf-m**

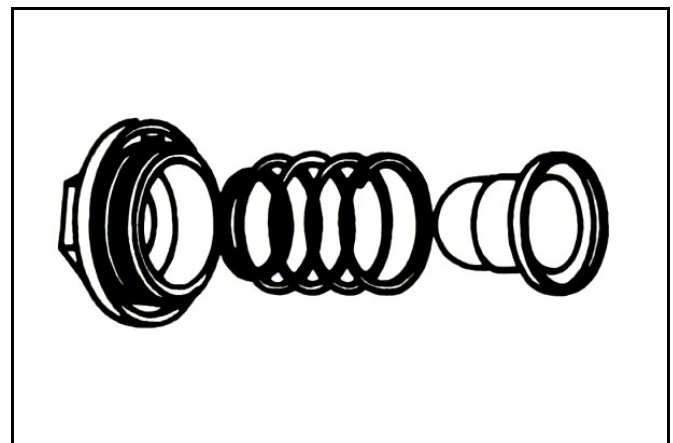
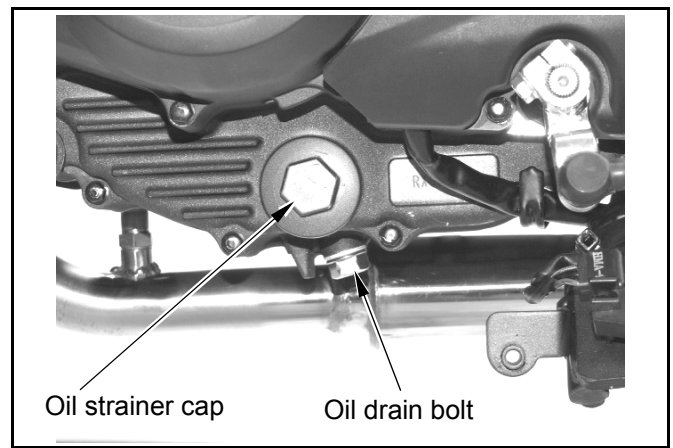
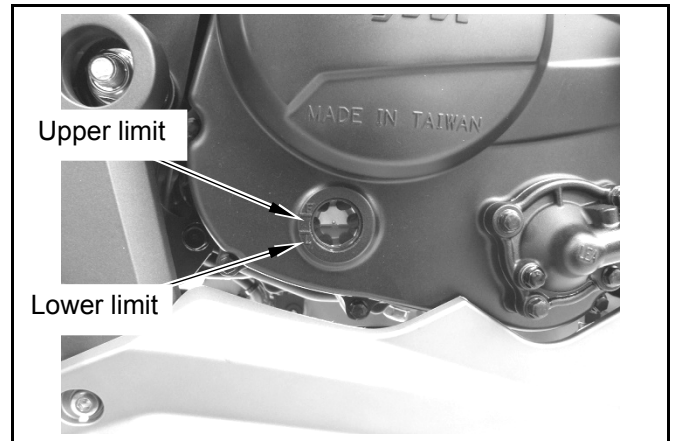

## 2. Maintenance Information



### Replace oil filter

Remove bolts of oil filter chamber.

Remove the filter and replace it with a new one.

#### Caution

- Oil filter is paper type and cannot be cleaned or reused.

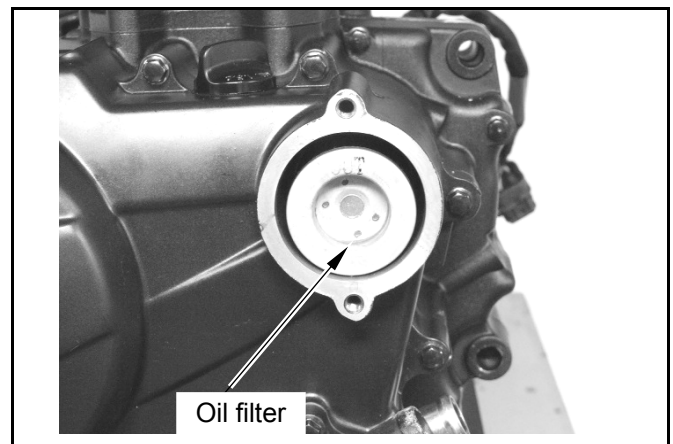
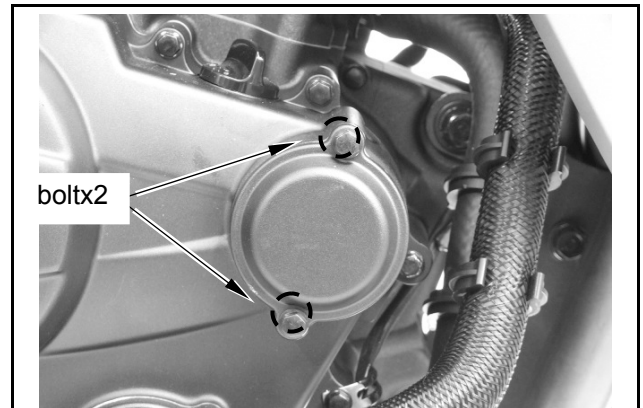

### Cylinder compression test

Warm up engine and turn it off.

Remove left cylinder head cover

Remove spark plug cap and spark plug.

Install compression gauge into the spark plug hole, full open the throttle, and rotate the engine.

#### Caution

Rotate the engine until the reading in the gauge gains no more.

- Usually, the highest-pressure reading will appear in 4~7 seconds.

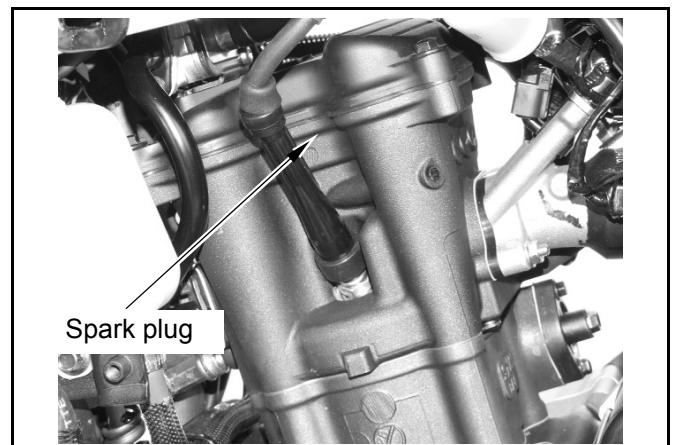

### Compression pressure : $12 \pm 2$ Kg/cm<sup>2</sup>

Check the following items if the pressure is too low:

- Incorrect valve clearance.
- Valve leakage
- Cylinder head leakage. Piston, piston ring, cylinder damaged.

Over-high pressure means combustion chamber or piston top deposit carbon.

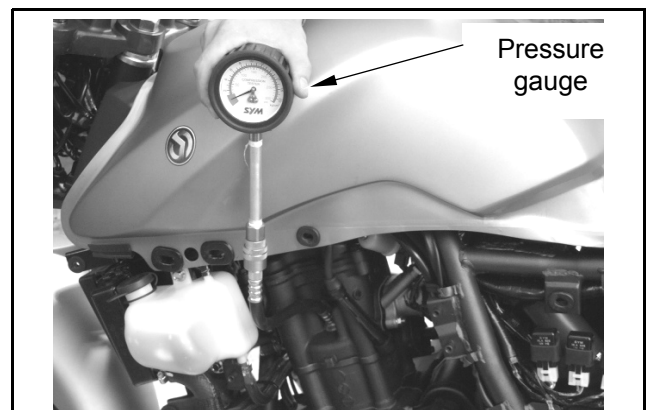

### Fuel System

#### Fuel lines

Check all fuel lines, and replace when they are deteriorated, damaged or leaking.

#### Caution

- Gasoline is a highly flammable substance, so any source of fire or spark is strictly prohibited when operation.

#### Fuel filter

#### Warning

- Any source of fire or spark is strictly prohibited when operation.
- Fuel filter is sealed type, replace it if it is clogged.

Remove seat, fuel tank, and fuel pump.

Check if fuel filter is clogged or broken; replace it with a new one when necessary.

Check the fuel line for leakage.

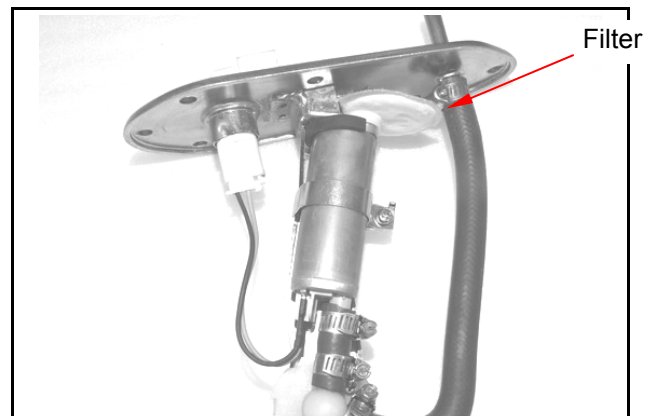
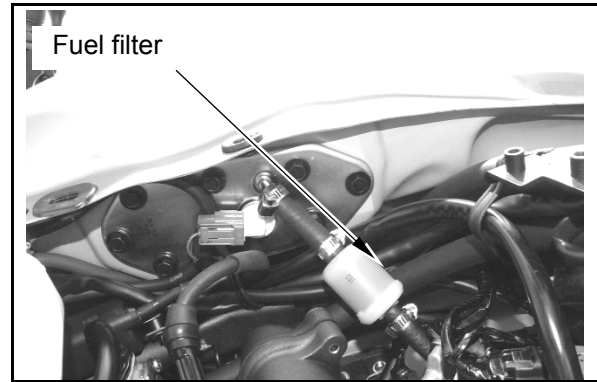

### Air filter

#### Air filter element

Remove the seat.

Remove the air filter cover (4 Screws)

Remove the air filter element

Check if the filter element is dirty or damaged.

If the air cleaner filter element is too dirty or damaged, please replace with new parts.

#### Caution

- The air filter element is paper type and cannot be soaked or washed, or engine performance will be affected.
- If the filter element is not installed correctly, dust will be sucked into cylinder, which will result in decreased power and shortened engine life.

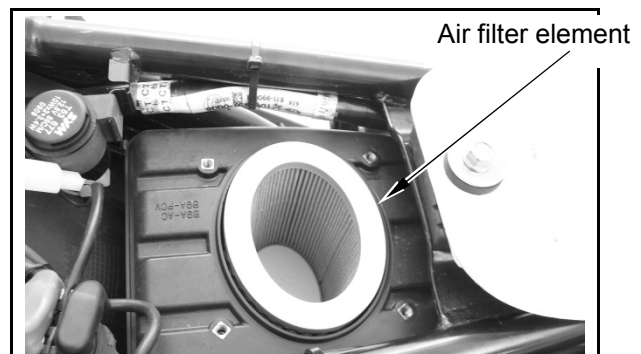
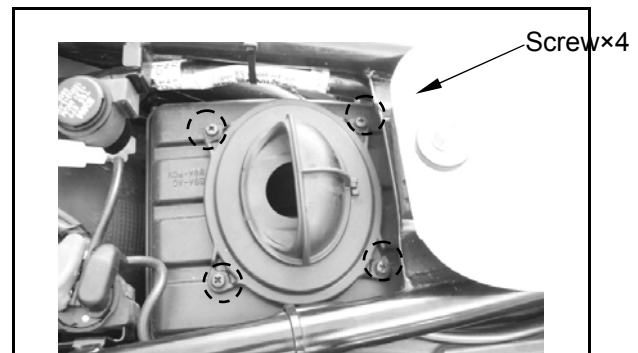

## 2. Maintenance Information



### Throttle operation

Operate the throttle grip to see if the throttle cable is going smoothly.

If the throttle cable is deteriorated, twisted or damaged, please exchange it.

If the cable does not go smoothly, lubricate the cable.

Measure the free play of the throttle grip, through the inner side flange of it.

**Free play : 2~6 mm**

Adjustment can be done on both side of throttle cable.

Conduct secondary adjustment on upper side.

Loose fix nut and rotate it to adjust free play.

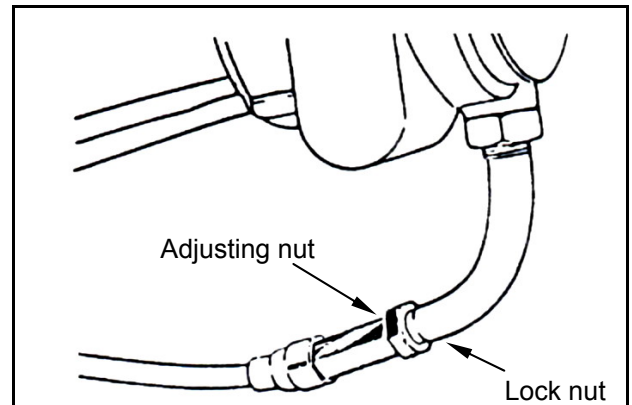
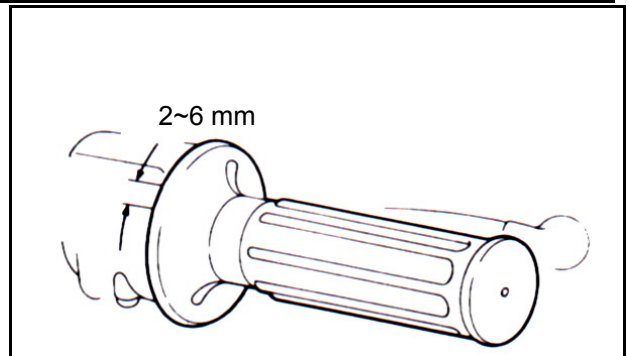

### Spark plug

**Recommended spark plug : CR8E**

Remove cylinder head left cover. (boltX3)

Remove spark plug cap.

Clean dirt around the spark-plug hole.

Remove spark plug.

Measure spark plug ignition gap.

**Spark plug gap : 0.7~0.8 mm**

Carefully bend ground electrode of the plug to adjust the gap if necessary.

Hold spark plug and install the spark plug by screwing it with hand, after tightening the plug by hands, use plug socket to tighten it to the standard torque value.

**Standard torque : 1.0~1.2kgf-m**

Install the spark plug cap.

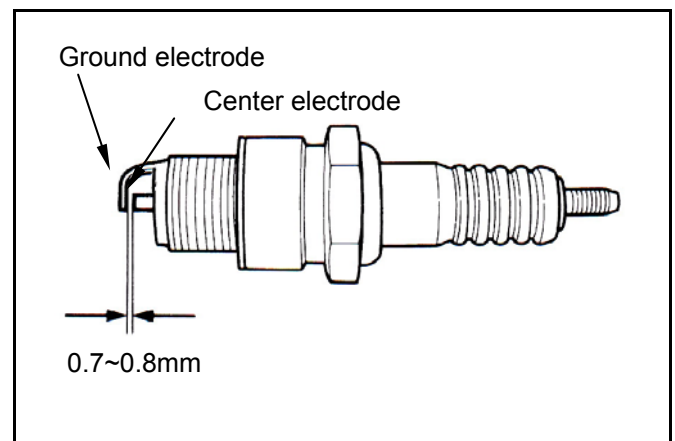
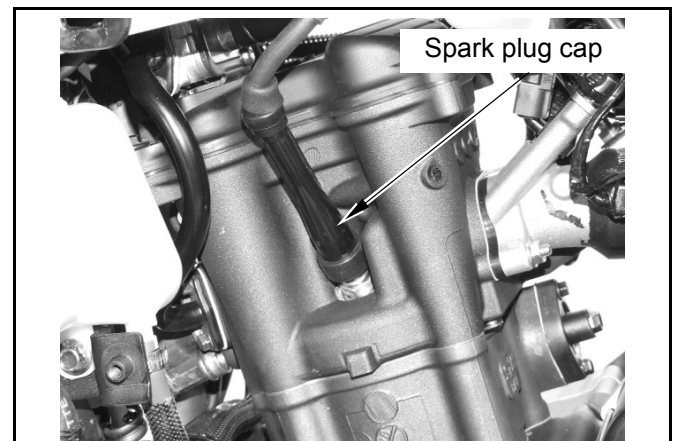

### PCV System

Unplug the drain tube, and leak the deposit off.  
Drain the tube every 2,000 km.

#### Caution

- Under rainy or full-throttle situation, the maintenance period should be shortened. You can check the deposit amount through the transparent tube.

### Valve clearance Adjustment

#### Caution

- The valve clearance should be adjusted when the engine is cold. (Under 35°C)

Remove fuel tank. Remove cylinder head.  
Remove cylinder head side cover.  
Remove the timing inspection cap and the AC.G cap on the crankcase L cover.  
Use a T socket wrench to rotate the crankshaft counterclockwise. Align the "T" mark on the AC.G flywheel with the crankcase sign, and simultaneously, the cam-chain sprocket TDC mark aligning with the cylinder head mark (That means the piston is in the upper end of compression stroke)

#### Valve clearance inspection & adjustment

Check the intake and exhaust valve clearance by inserting the feeler gauge between the adjusting screw and the lock nut.

**Valve clearance :** IN:  $0.10 \pm 0.02$  mm  
EX:  $0.15 \pm 0.02$  mm

Adjust by loosening the lock nut first, and turning the adjusting screw.

#### Caution

- When adjusting valve clearance, make sure all clearance on standard volume; recheck after tightening lock nuts.

Install cylinder head, cylinder head side cover, timing inspection cap, and the AC.G cap

#### Caution

- Before installing cylinder head side cover, timing inspection cap, and the AC.G cap, check if the O-ring is damaged, and apply some oil on it.

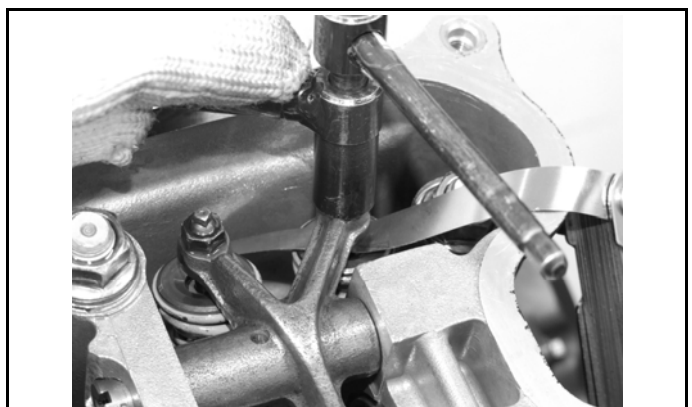
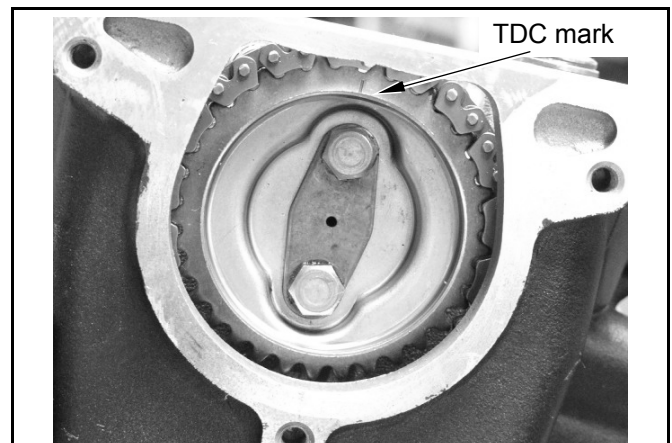
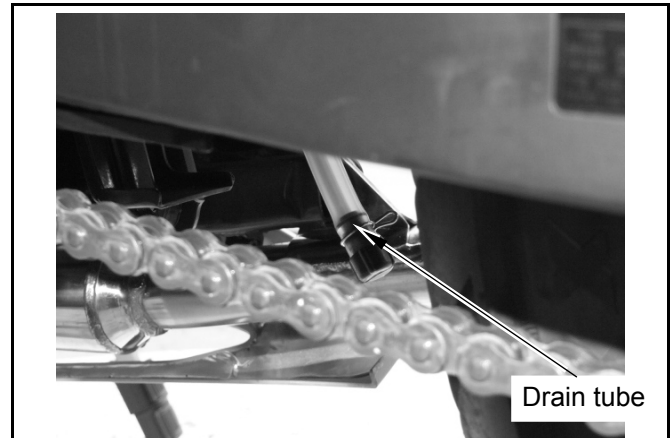

## 2. Maintenance Information



### Drive chain adjustment

#### Drive chain inspection

Place the bike on its main-stand with its neutral gear. Check the drive chain slack by moving the chain up and down by fingers, and measure the amount of chain slack.

**Standard chain slack : 10~20 mm**

#### Caution

- Because the front and rear sprocket have different wearing situations, so please rotate the rear wheel to find the minimum chain slack for the measurement.

#### Drive chain adjustment

If you need to adjust the chain slack, please loosen the rear axle nut and sleeve nut first. Turn the left and the right side adjusting nut evenly to make the chain slack within the standard range. Turn the nuts clockwise to tighten the chain, or counterclockwise to loosen the chain.

**Torque value : 4.0~5.0kgf-m**

After tightening the rear axle nut, please check the sleeve nuts to prevent them from loosening. Recheck the chain slack, and make sure the rear wheel rotates smoothly.

If the chain is too dirty, use high-flash point solvents to clean the chain. (Kerosene or Diesel.)

#### Caution

- Don't use gasoline when cleaning the chain. The gasoline will damage the O-ring in the chain.

After cleaning, lubricate the chain with chain lubricant.

### Steering mechanism

#### Caution

- Check all wires and cables if they are interfered with the rotation of steering handle bar.

Lift the front wheel off the ground.

Turn handle from right to left and check if turning is smoothly.

If handle is uneven or bending, or the handle can be lifted through vertical direction, adjust the handle top bearing.

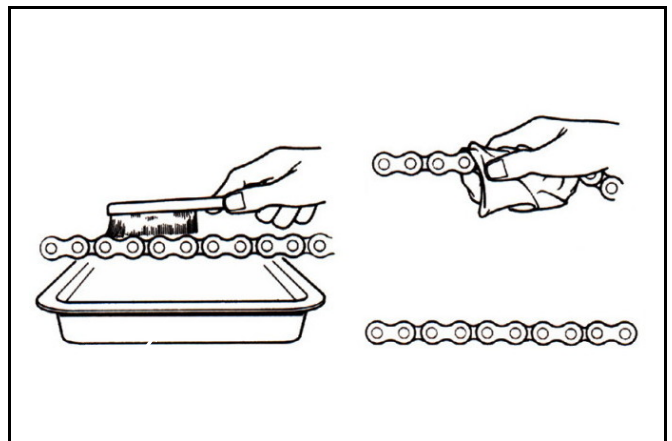
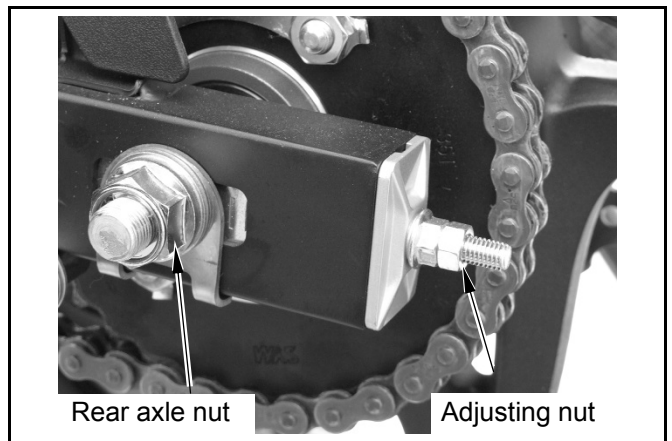

### Suspension system

#### ⚠ Caution

- Do not ride the motorcycle with poor cushion.
- Loosened, worn or damaged cushion will make poor stability and maneuverability.

#### Front cushion

Press down the front cushion several times to check its integrity.

Check if any oil leakage or damage.

Replace relative parts if damaged.

Tighten all nuts and bolts.

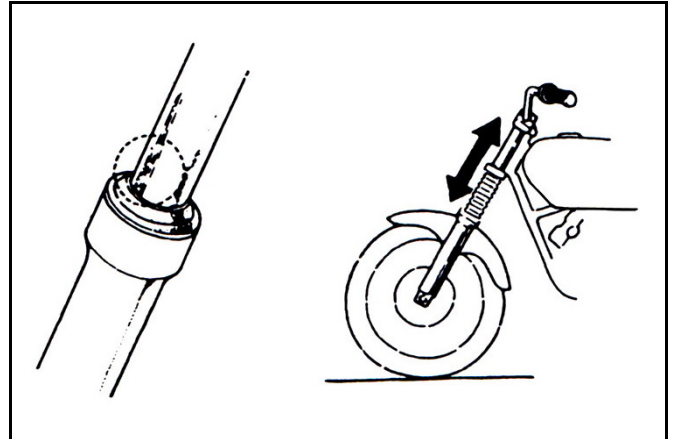

#### Rear cushion

Press down the rear cushion several times to check its integrity.

Check if any oil leakage or damage.

Replace relative parts if damaged.

Start the engine and gradually rise R.P.M. to rotate the rear wheel; check if any looseness, vibration; replace bushing if damaged.

Tighten all nuts and bolts.

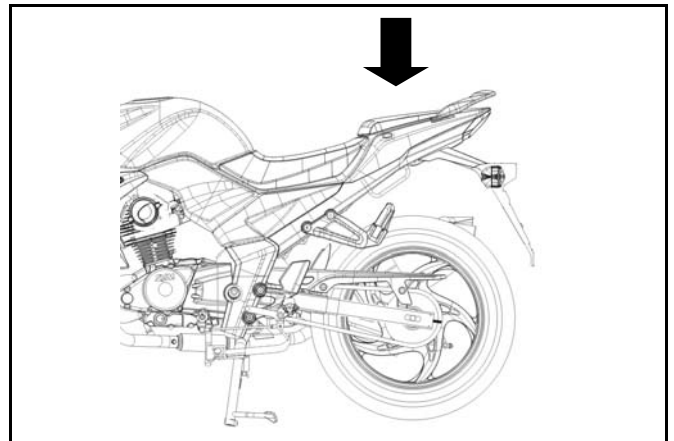

### Disk brake system

#### Brake System Hose

Check the brake hoses for corrosion or brake fluid leaking.

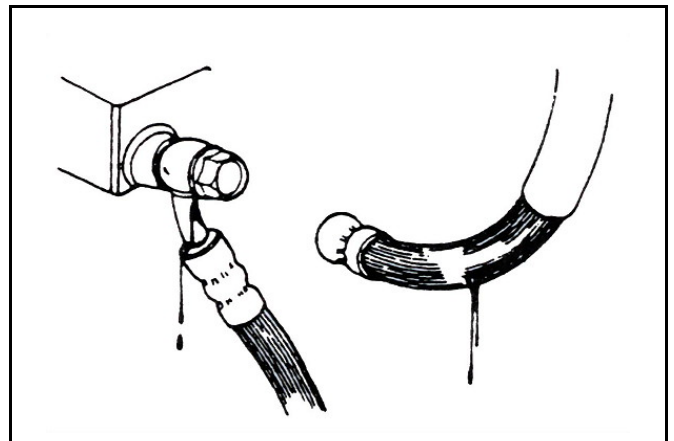

#### Brake Fluid

Check brake fluid level in the brake fluid reservoir. If the level is lower than the LOWER limit, add brake fluid to UPPER limit. Also check brake system for leaking if low brake fluid level found.

#### ⚠ Caution

- To keep the reservoir in horizontal position, do not take off the brake fluid cap before keeping the steering handle steady.
- Do not operate the brake lever after the cap removed. Otherwise, the brake fluid will be sprayed out.
- Do not mix non-compatible brake fluid.

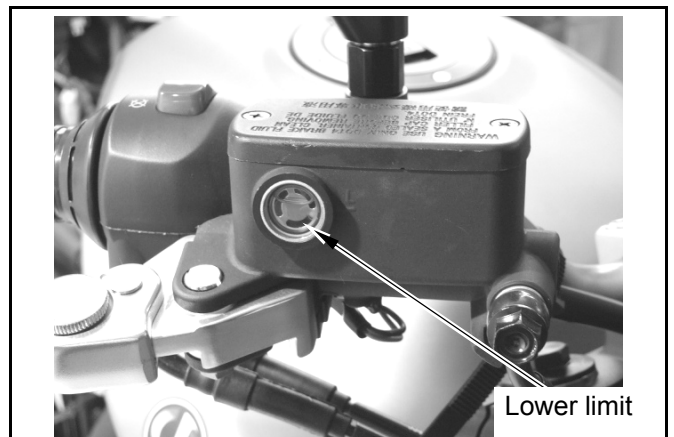



## 2. Maintenance Information



### Air bleeding operation

Connect a transparent hose to air-bleeding valve. Hold the brake lever and turn the air-bleeding valve open. Perform this operation several times until there is no air bubble inside the transparent hose.

#### Caution

- Before closing the air bleed valve, do not release the brake lever.

### Add Brake Fluid

Add brake fluid to UPPER limit.

Recommended brake fluid: DOT3 or DOT4 WELL RUN brake fluid.

#### Caution

- Never mix or use dirty brake fluid to prevent braking system from deterioration or reducing brake performance.

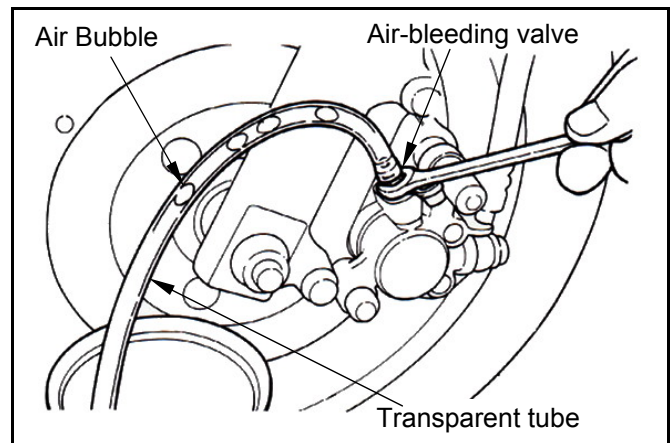
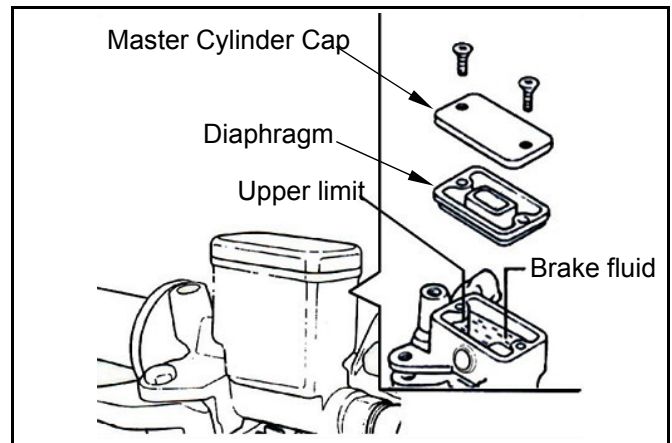

### Brake Lining Wear

The indent mark on brake lining is the wear limitation.

If the wear limit mark approximates the edge of brake disc, replace the brake lining.

#### Caution

- It is not necessary to remove brake hose when replacing the brake lining.

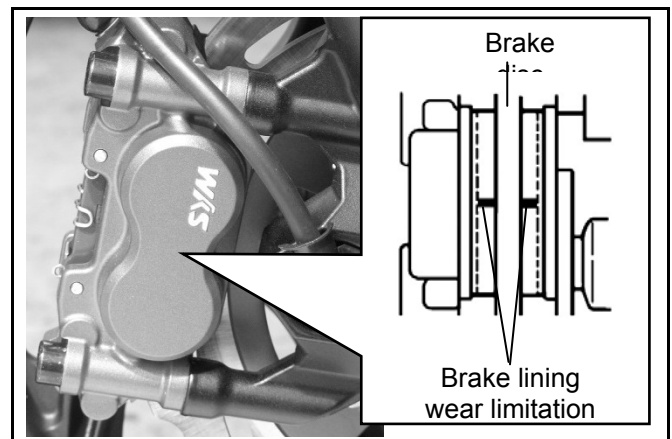

### Tire

Check the pressure of the tire to see if it is in the specified pressure range.

 **Caution**

- Tire pressure check should be done when the tire is cold.

#### Specified tire pressure range

Tire pressure		Front	Rear
Tire pressure when cold (Kg/cm <sup>2</sup> )	Single riding	2.0	2.0
	Dual riding	2.0	2.25

#### Specified tire:

**Front : 110/70-17 54H**

**Rear : 130/70-17 62H**

Check if tire surface is stuck with nails, stones or other objects.

Check if tire surface and wall are damaged or worn, replace when necessary.

Check tire tread depth with eye or tire depth gauge.

Replace the tire if it is uneven worn or insufficient tread depth.

If the wearing of the tire thread reaches triangle TWI mark index, the tire have to be replaced.

Measure tire thread depth from tire central surface, replace the tire, if the depth is not enough.

Minimum tread depth:

Front wheel: 1.5 mm

Rear wheel: 2.0 mm

 **Caution**

- The triangle TWI mark index is located along the tire wall.

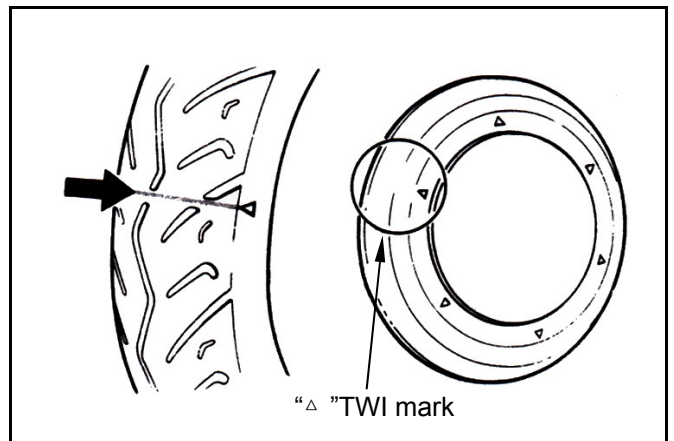
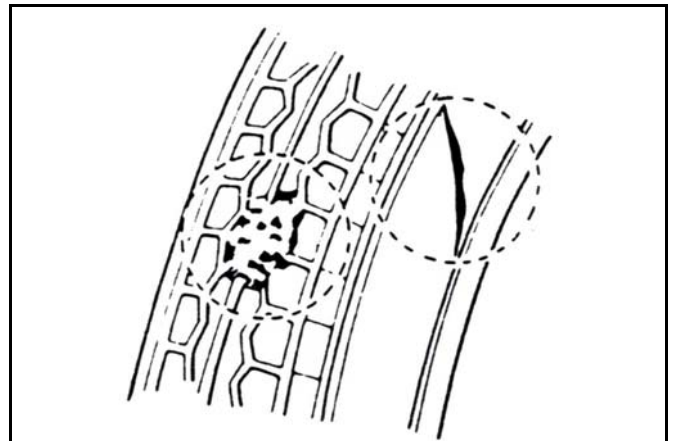
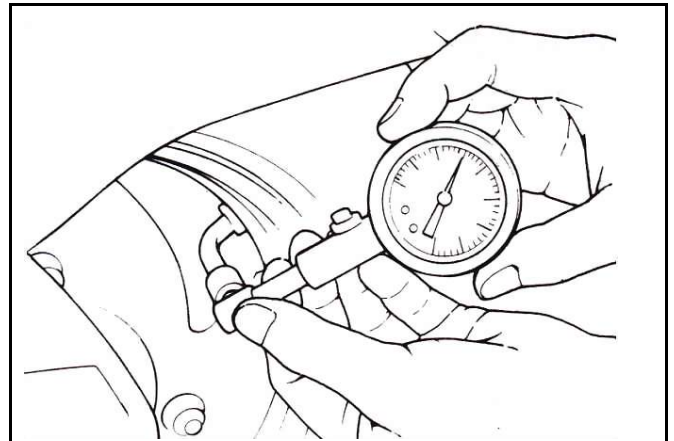

### Battery

#### Battery removal

Remove the seat

Remove the “-” negative pole first, then remove the “+” positive pole.

Remove the battery holder and take out the battery.

#### ⚠ Caution

- If the rust on the posts is very serious, spray some hot water on them. Then, you can remove the rust by steel brush more easily.
- Apply some grease on the posts after cleaning rust to prevent from happening again.

If there is some rust on battery posts, clean it with steel brush.

Install the battery in the reverse procedures of removal.

**Battery model : GT12A-BS**

### Clutch adjustment

#### Clutch lever free play inspection

Slightly pull the clutch lever to check the free play before clutch disengagement.

**Free play : 10~20 mm**

#### Clutch lever free play adjustment

Before adjusting the clutch lever free play, please loosen the lock nut first. Then turn the adjusting screw to achieve the recommended clutch free play. If you want to decrease the free play of clutch lever, turn it clockwise. If you want to increase the free play, turn it counterclockwise. After adjustment, tighten the adjusting nut with lock nut.

Lubricate the clutch cable.

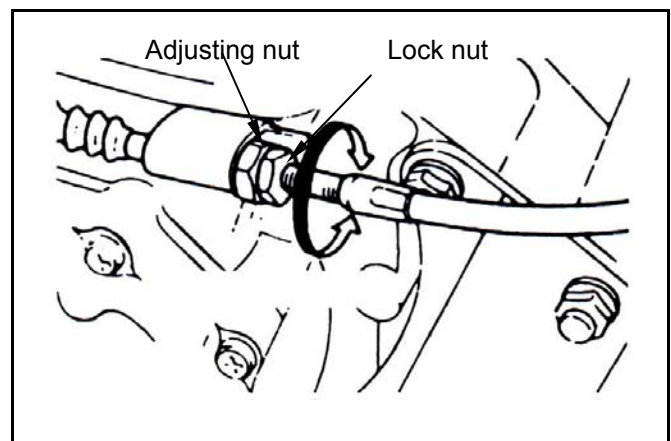
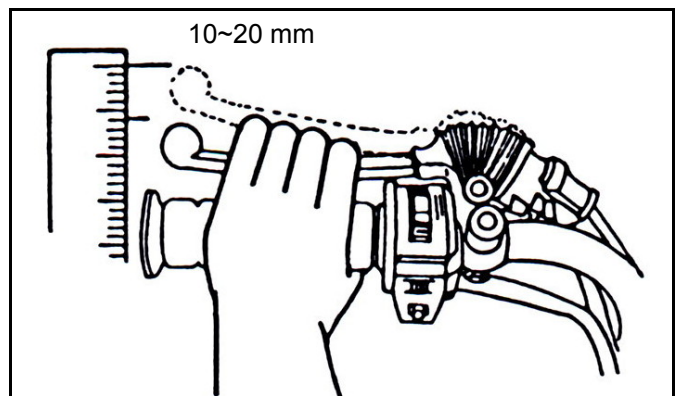
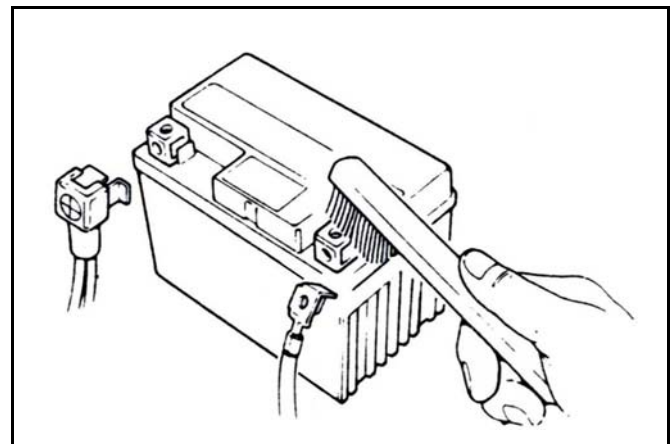
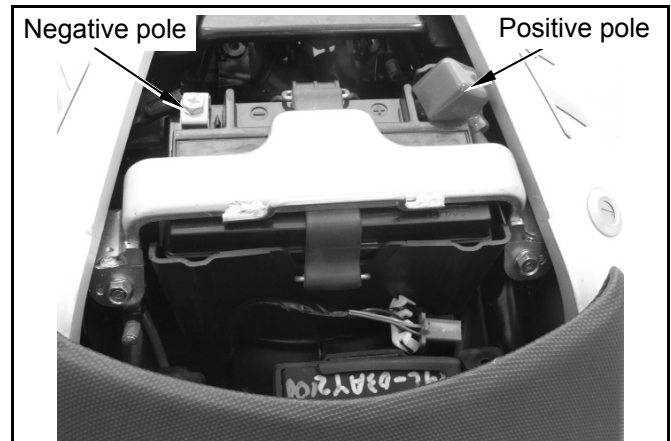

### Headlight adjustment

Turn on main switch. Loosen the headlight adjustment screw to adjust headlight beam height.

#### Caution

- The factory setting of the beam height is consistent with government orders.
- Improper headlight beam setting will make driver in the opposite lane dazzled and cause danger.



### Brake switch

#### Inspection on the brake switch

When brake lever is pulled, brake switch will light up the brake lamp.

Make sure that electrical starter can be activated only under braking condition.

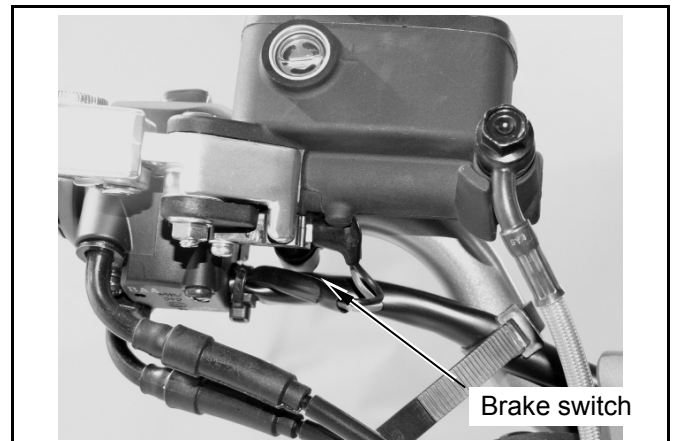

#### Adjustment of rear brake switch

Turn on the main switch.

When the brake pedal is stepped down for 20mm, the brake lamp should be activated.

If the brake lamp is not activated or activated too early, please adjust through the rear-brake-switch adjusting nut.

Turning clockwise will decrease the free play, and counterclockwise will increase the free play.

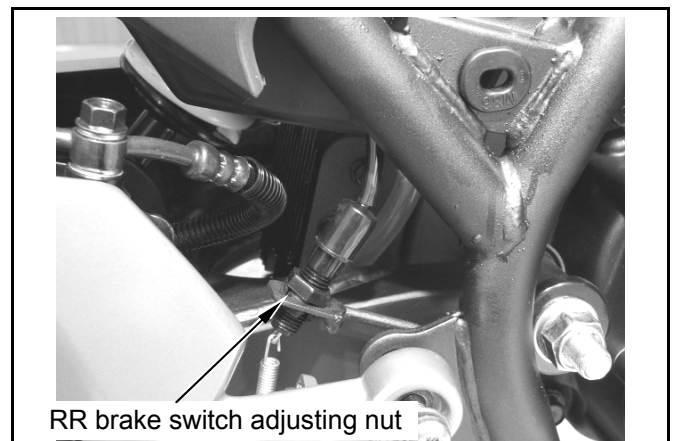

### Nuts, bolts tightness

Apply periodical maintenance in according with the Periodical Maintenance Schedule.

Check if all the bolts and nuts on the frame are tightened within standard torque.

Check all fixing pins, snap rings, hose (pipe) clamps, and wire holders for security.

## 2. Maintenance Information



### Special tools

					
Name	Rocker arm shaft disassemble tool	Name	Flywheel puller	Name	Valve remove and assemble tool
SY No.	SYM-1445100	SY No.	SYM-3110000-HMA	SY No.	SYM-1471110/20
					
Name	Valve spring compressor	Name	Tappet adjusting wrench	Name	Tappet adjusting tool
SY No.	SYM-1471100	SY No.	SYM-9001200	SY No.	SYM-9001210
		 (6203/6004UZ)		 (20*34*7)	
Name	Steering Nut Wrench	Name	6203/6004UZ bearing Driver	Name	20*32*6 oil seal driver
SY No.	SYM-5320000	SY No.	SYM-9620000	SY No.	SYM-9120200
 (6204)		 (6301)			
Name	6204 Bearing Driver	Name	6301 Bearing Driver	Name	Digital clamp meter
SY No.	SYM-9110400	SY No.	SYM-9610000	SY No.	SYM-HE07007-05

					
Name	Inner bearing puller set	Name	Outer bearing puller	Name	Bearing driver
SY No.	SYM-6204020	SY No.	SYM-6204001	SY No.	SYM-6204024
					
Name	Crankcase bush puller	Name	Cylinder pressure gauge	Name	Vacuum pressure gauge
SY No.	SYM-1120310	SY No.	SYM-HT07008	SY No.	SYM-HT07011
					
Name	Efi System Diagnostic tool	Name	Fuel pressure gauge	Name	Multi-meter
SY No.		SY No.	SYM-HT07010	SY No.	SYM-HE07007-01
					
Name	Vehicle circuit test tool kit	Name	Vehicle circuit test harness	Name	Fuel hose clamp
SY No.	SYM-HE170008	SY No.	SYM-HE170008-01	SY No.	SYM-1950500

## 2. Maintenance Information



					
Name	EFI fuel hose pliers	Name	EFI fuel hose removal pliers	Name	Water pump mechanical seal driver
SY No.	SYM-1768100	SY No.	SYM-1768110	SY No.	SYM-1721700-H9A
					
Name	Water pump bearing driver	Name	Water pump oil seal driver		
SY No.	SYM-9100100	SY No.	SYM-9120500-H9A		

EFi System Diagram.....	3-1	Fuel Tank .....	3-37
EFi System Operation .....	3-2	Fuel Pump.....	3-38
EFi System Introduction .....	3-3	Fuel Unit.....	3-39
Fuel System .....	3-4	Air Cleaner.....	3-39
Ignition System.....	3-5	EFi System Diagnosis Methods.....	3-40
Sensors / Drives .....	3-6	Check Light Fault Codes Differentiation..	3-41
Precautions in Operation.....	3-12	Fault Codes and Sensors Table.....	3-42
EFi System Components Description .....	3-13	Fault Code and Check Light Flashing Light Identification Table.....	3-43
EFi System Circuit.....	3-29	Troubleshooting Table .....	3-44
ECU Pin Configuration.....	3-30	Comprehensive Maintenance List.....	3-45
Troubleshooting .....	3-31		
Intergrated Troubleshooting Procedure..	3-35		

#### EFi system diagram

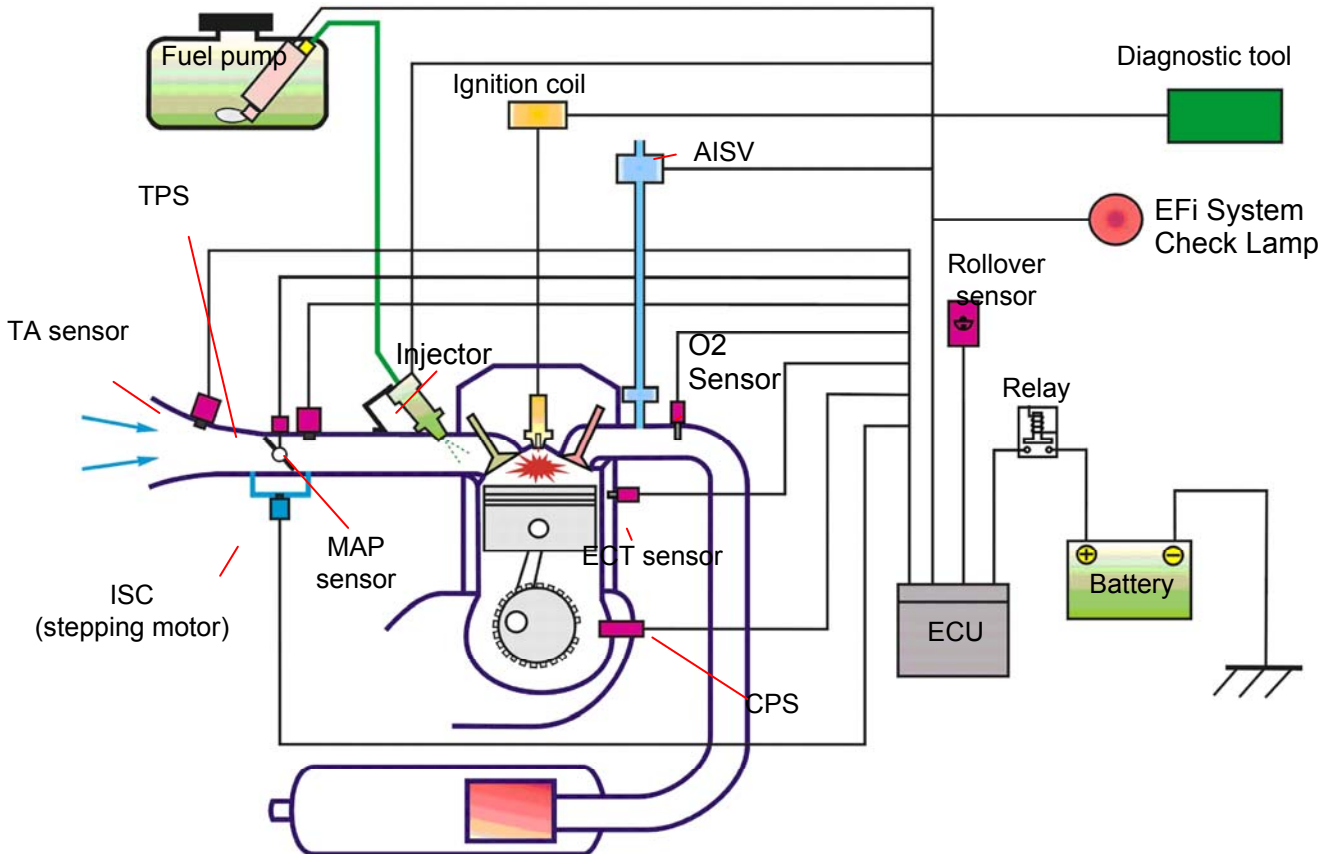



# 3. Fuel Injection System



## EFi system operation

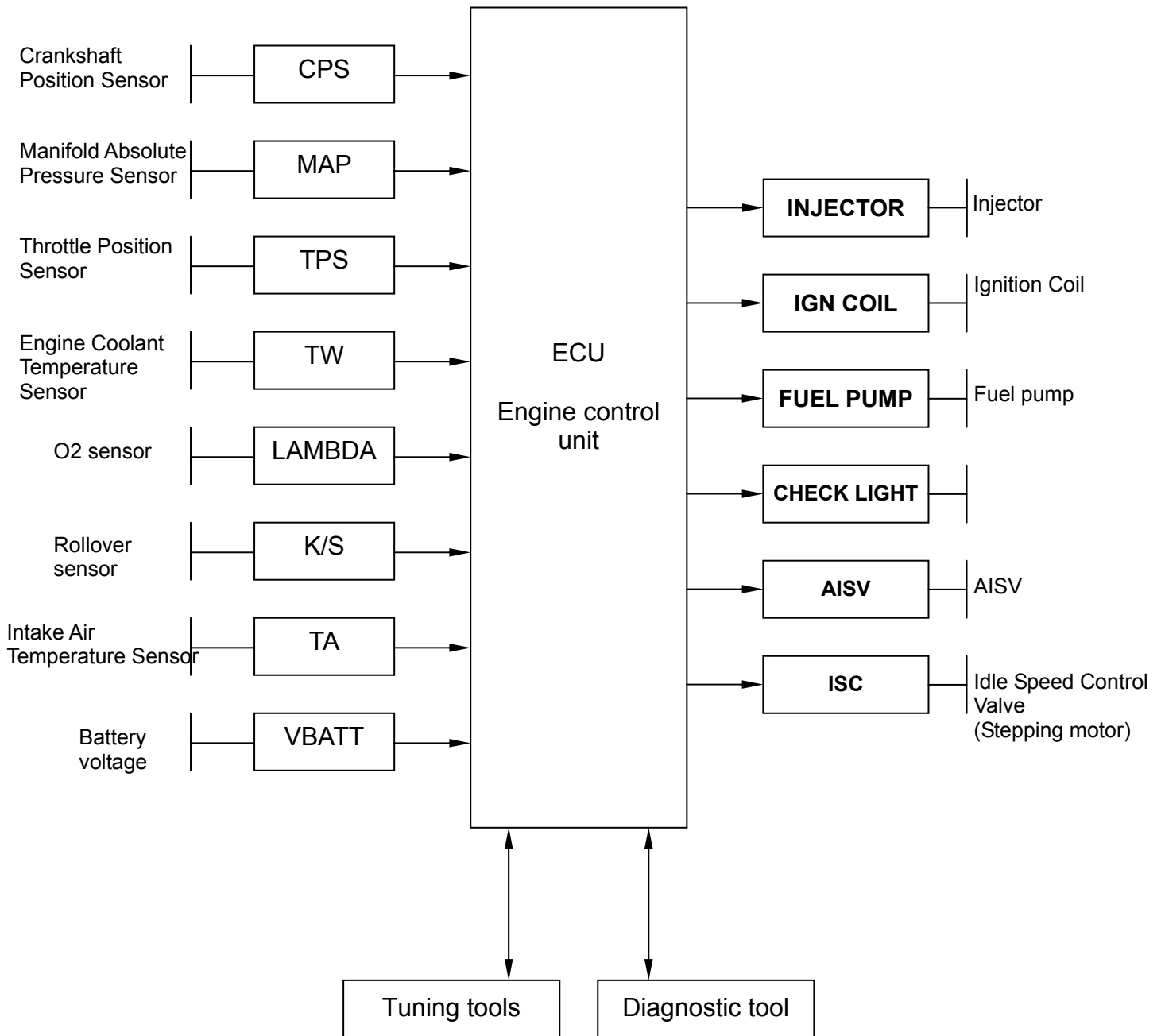

### EFI system introduction

Based on 4-stroke SOHC engine, displacement 250 c.c. electronically controlled fuel injection. Fuel vapor will be absorbed by carbon canister; blow-by gas from crankcase will be introduced to combustion chamber. The O<sub>2</sub> sensor enhances the efficiency of the catalytic converter by dynamically controlling the air / fuel ratio.

### Electrical fuel injection system

Electrical fuel injection system is constructed by fuel supply device: fuel tank, fuel pump, fuel filter, pressure regulator, and fuel control device: injector, ECU.

The fuel is pumped by electrical fuel pump in the fuel tank to the injector on the intake manifold (inlet pipemanifold). The fuel pressure regulator keeps the pressure around  $294\pm 6$ kpa. The signals from ECU enable the injector to spray fuel into the combustion chamber once each two crankshaft-revolutions. The excessive fuel flows back to the fuel tank through the fuel pressure regulator. Fuel pump is placed inside the fuel tank to reduce the working noise and simplify the fuel system. Electrically controlled ignition and injection system effectively reduce fuel consumption rate and pollution.

In traditional gasoline engine, carburetor supplies the fuel. The engine vacuum generates negative pressure in the carburetor; then fuel mixed with air and together the mixed gas sent into combustion chamber. Under this condition, air-fuel ratio is determined by air and fuel sucked in. Thus, the three major processes are done simultaneously in the carburetor: air quantity measurement, the determination of fuel quantity, the mix of fuel and air.

Electrical fuel injection system checks intake air quantity and temperature; on this basis, the programmed air-fuel ratio in the ECU determines the amount of fuel to be injected; then the injector sprays the fuel. The difference between carburetor and electrical fuel injection is that the three mechanisms are independent which will lead to more precise fuel control and supply.

EFI engine uses computer-programmed fuel injection, the main features are:

1. The quantity of fuel injected is determined according to the condition of the engine. The engine RPM and throttle position determines the fuel quantity and injection time-length.
2. The quantity of fuel injection, and the determination of injection time length, are all controlled by 16-bit microcomputer.
3. The fuel pressure regulator maintains a  $294\pm 6$ kpa pressure difference between inlet pipe and fuel pipe, raising the accuracy of fuel injection.
4. By measuring the air pressure of inlet pipe, this system gives the vehicle better accommodation to the environment.
5. Idle speed control system supplies by-pass air to stabilize the idle running and cold starting.
6. O<sub>2</sub> sensor feeds back the signal to minimize the exhaust pollution.

### Fuel system

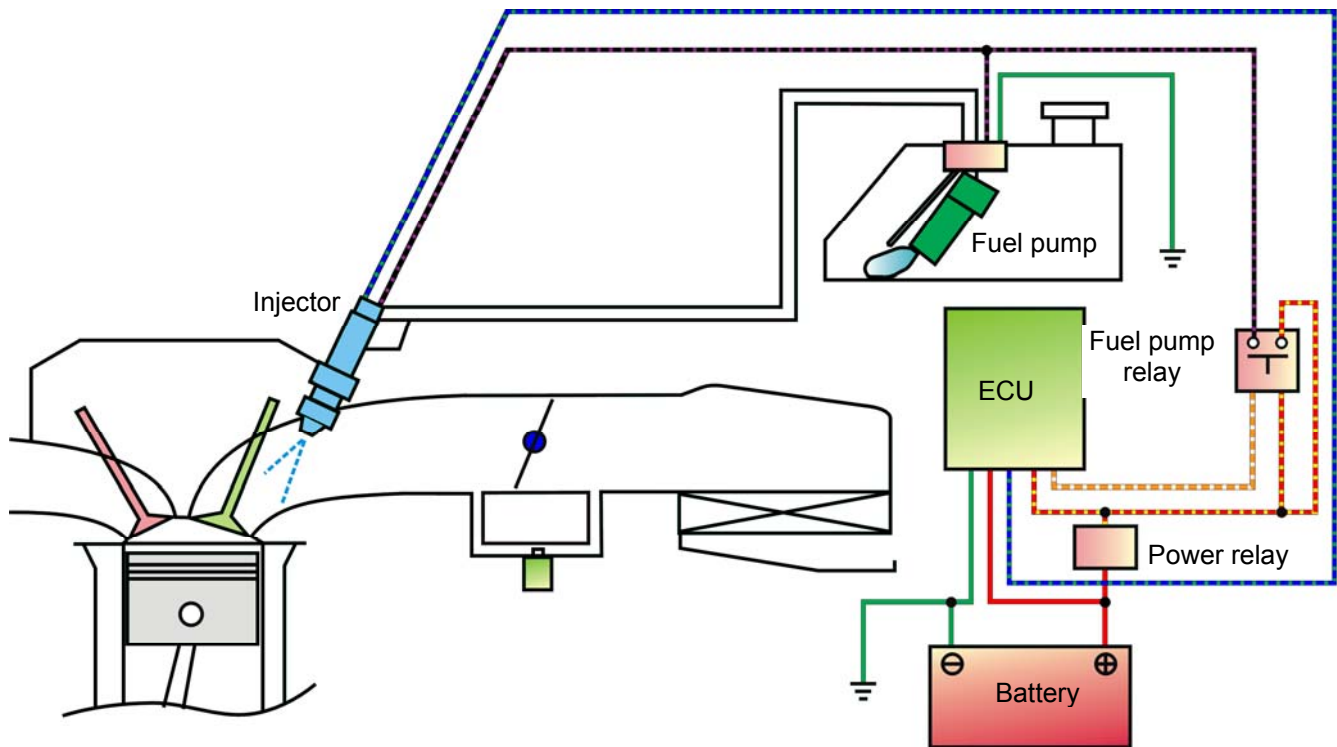

#### System description

1. After Key-on, the sensors send signals to ECU. ECU controls the fuel pump relay to make the fuel pump operate. If the engine is not started, the fuel pump will be shut down within 2 to 3 seconds in order to save electricity. Fuel pressure regulator maintains fuel pressure at  $294 \pm 6\text{kPa}$  (about  $3 \text{ kg / cm}^2$ ). According to the operating conditions and environmental compensation coefficient, appropriate fuel will be injected. After Key-off or engine stops operating, the fuel pump stops running.
2. Fuel filter filtrates impurities in the fuel. Replace it periodically.
3. When the engine cannot be started, do not keep starting the motor, which may reduce battery power (less than 10 V), and the fuel pump will not be able to operate. The correct way is to use a new battery.

#### Injector

Ten-hole type injector provides fuel injection, enhances the effect of fuel atomization, and reduces HC emission. Short-type injector cap can easily fix the injector, receive the fuel from the fuel pump, and limit injector rotation sliding. The signals from ECU control the fuel pressure regulator, using the diaphragm and spring to maintain the fuel pressure in  $294 \pm 6\text{kPa}$  (about  $3 \text{ kg / cm}^2$ ), and determine the fuel injection quantity by adjusting injection time width under different engine conditions.

#### Fuel pump

Electrical fuel pump is placed inside the fuel tank, powered by the battery and controlled by ECU. Fuel pressure:  $294 \pm 6\text{kPa}$  (about  $3 \text{ kg / cm}^2$ )

## Ignition system

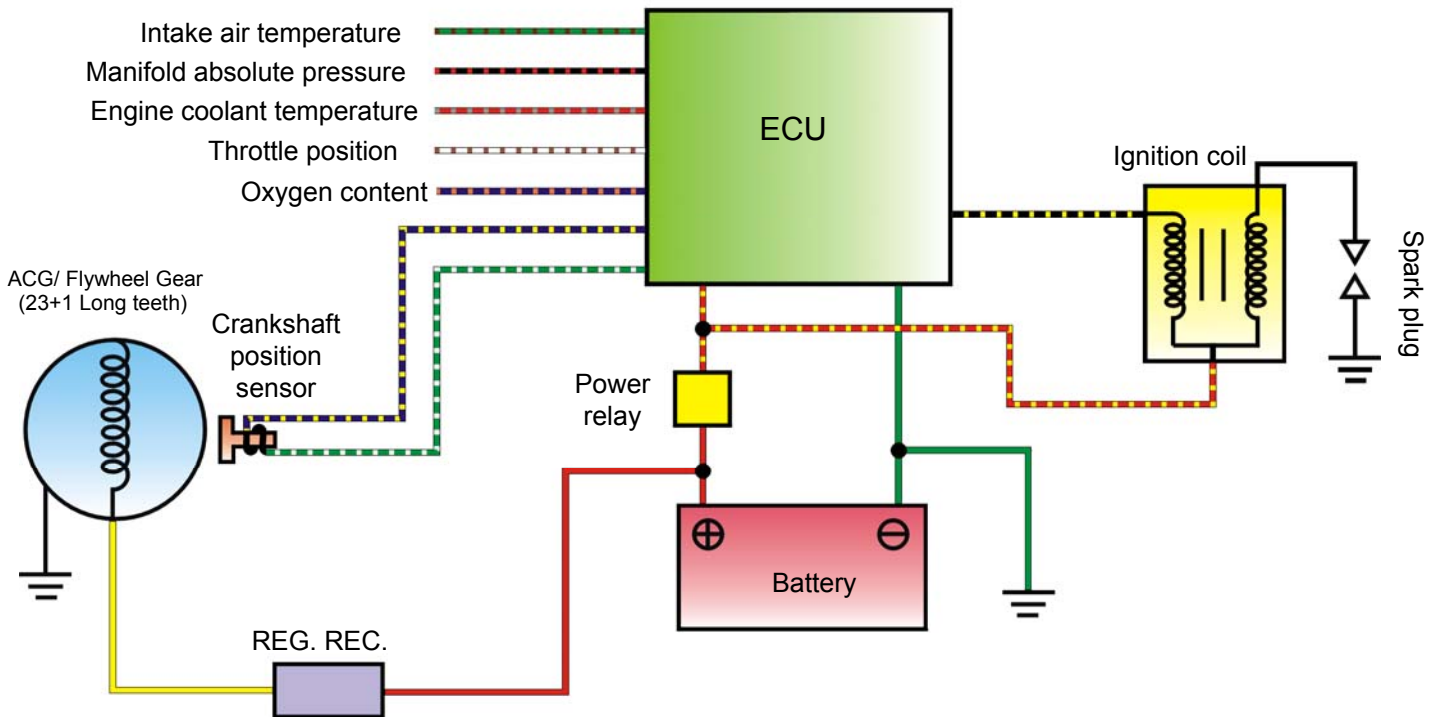

### Principle

The computer programmed ignition system receives the signals from the crankshaft position sensor, throttle position sensor, O<sub>2</sub> Sensor, MAP sensor, intake air temperature sensor, engine coolant temperature sensor. Calculating the engine RPM, the 16-bit microcomputer determines the appropriate ignition timing, controls the ignition coil and triggers the spark plug. This way can not only make the engine achieve the maximum power output, but also help improve fuel consumption rate.

### Specification

1. Ignition timing: BTDC 10 ° / 1650RPM
2. Spark plug: NGK CR8E Clearance:0.7~0.8mm
3. ACG crankshaft position sensor coil resistance:  $120\Omega \pm 20\%$  (green/white-blue/yellow)
4. Ignition coil primary circuit resistance:  $2.8 \Omega \pm 15\%$  Secondary circuit : with cap  $9.0K\Omega \pm 20\%$  without cap  $14.0K\Omega \pm 20\%$
5. Battery Type / Capacity: GT12A-BS / 12V 10Ah

### 3. Fuel Injection System



#### Sensors / drives

#### Crankshaft position sensor (CPS)

#### Function:

CPS identifies the teeth on the flywheel and sends voltage signal to ECU.

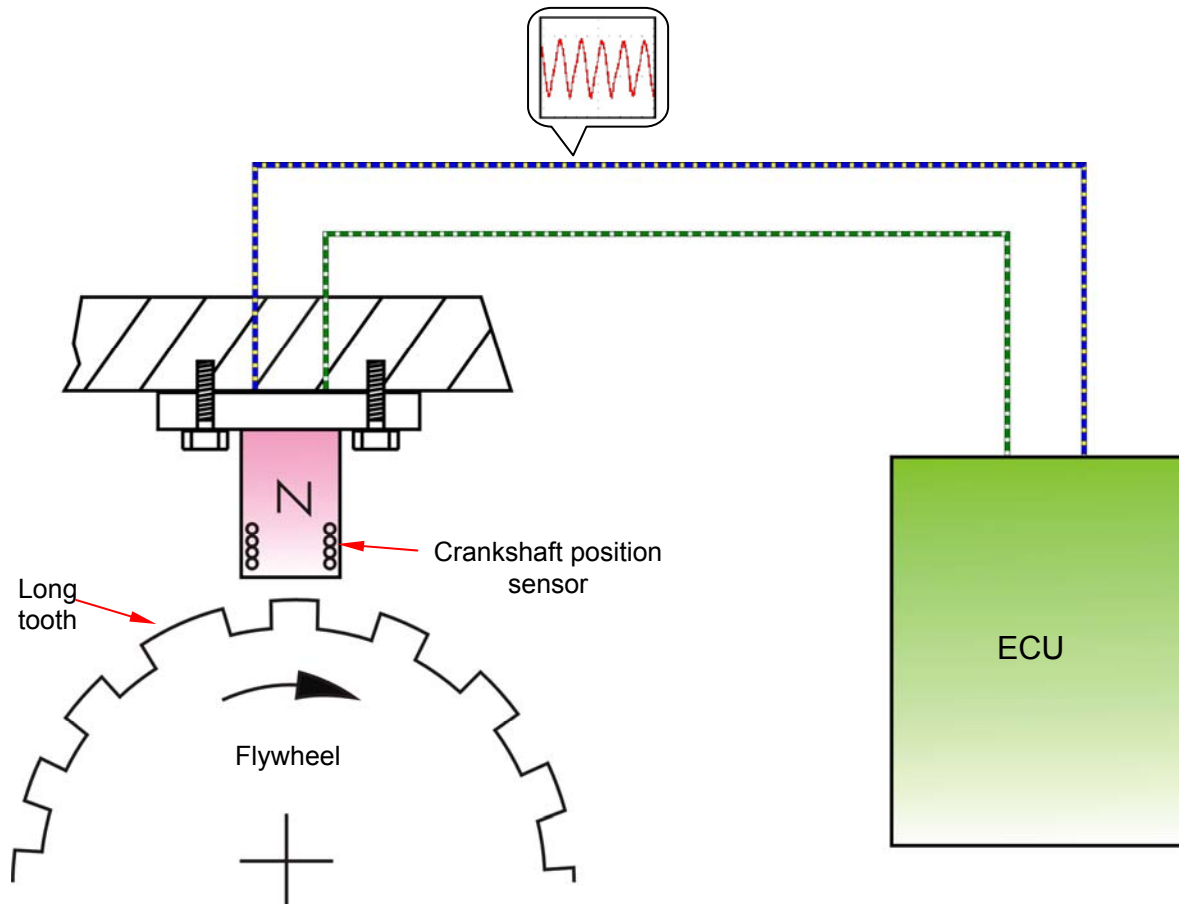

#### Description

Right after the engine is started; the crankshaft position sensor identifies the TDC position by detecting the long tooth on the flywheel and ignites at the fixed angle. When the engine RPM reaches the specified speed, the ignition timing will change to the software mode.

#### Manifold absolute pressure (MAP) / Engine water temperature (TW) / Intake air temperature (TA) sensor

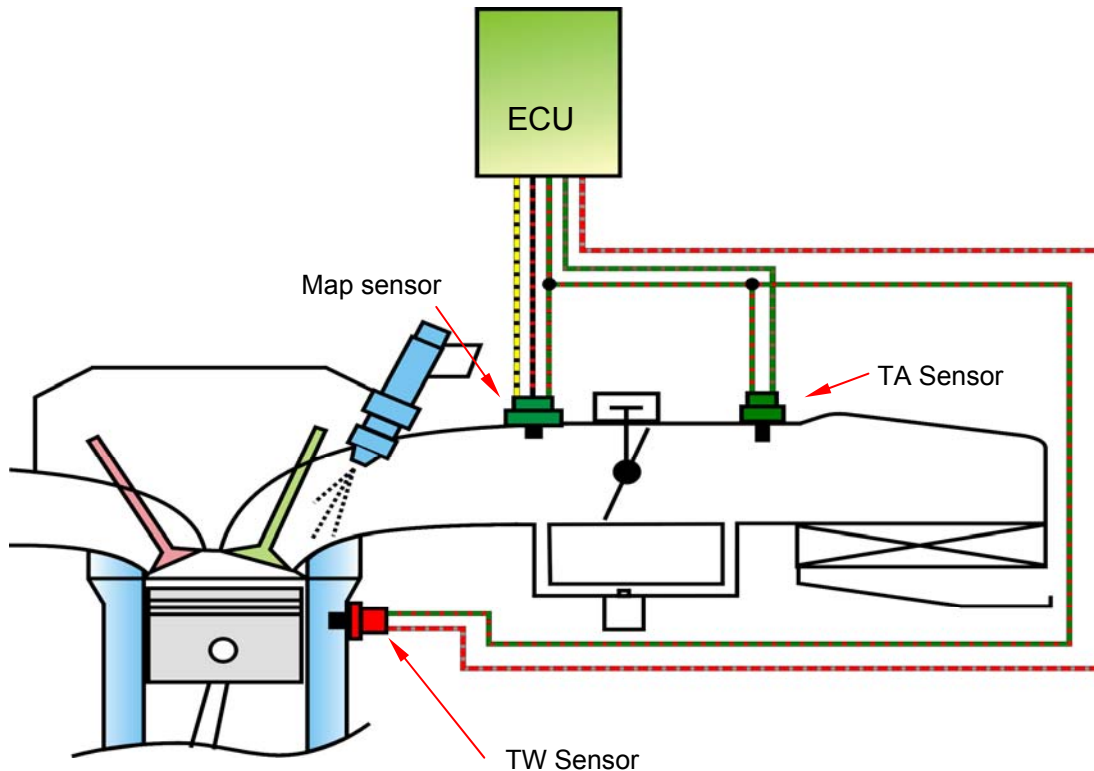

**Engine water temperature / Intake air temperature sensor:** Use the variable resistor of negative temperature coefficient (thermistor) to identify the outside temperature. The electrical resistance value goes down when the temperature rises. On the contrary, the electrical resistance value becomes higher when the temperature falls. Sensors provide the temperature of the engine coolant and intake air to ECU to determine the injection and ignition timing.

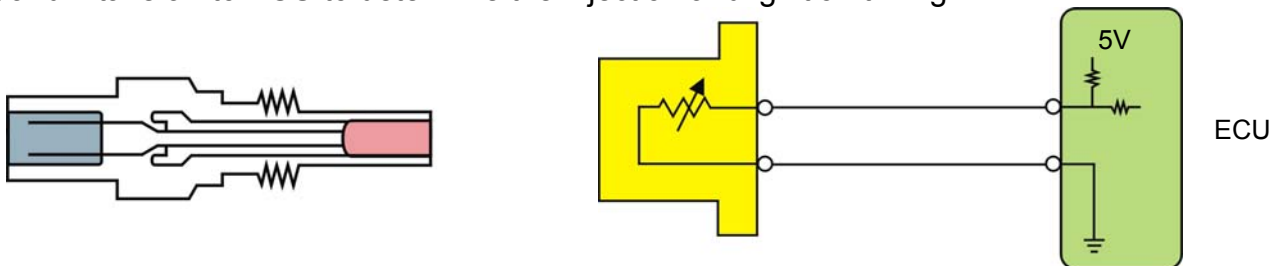

**Manifold absolute pressure sensor:** uses the piezoresistive resistor composed of silicon diaphragm, forming the Wheatstone bridge circuit to measure the atmospheric pressure and the intake manifold pressure, which are both transmitted to ECU as reference of engine control.

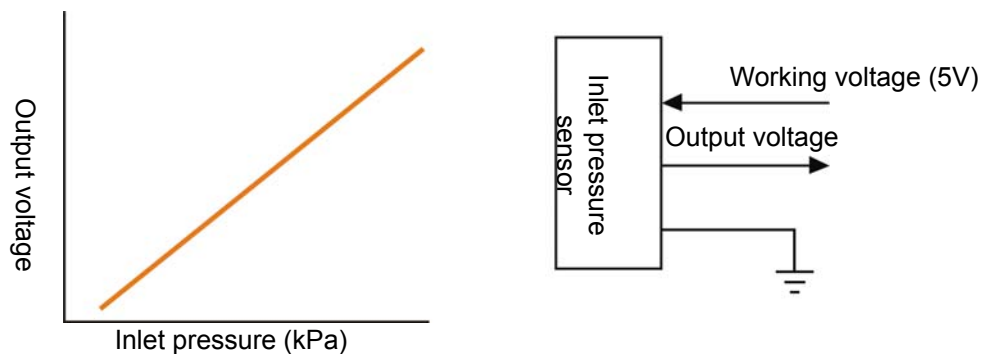

## O2 Sensor

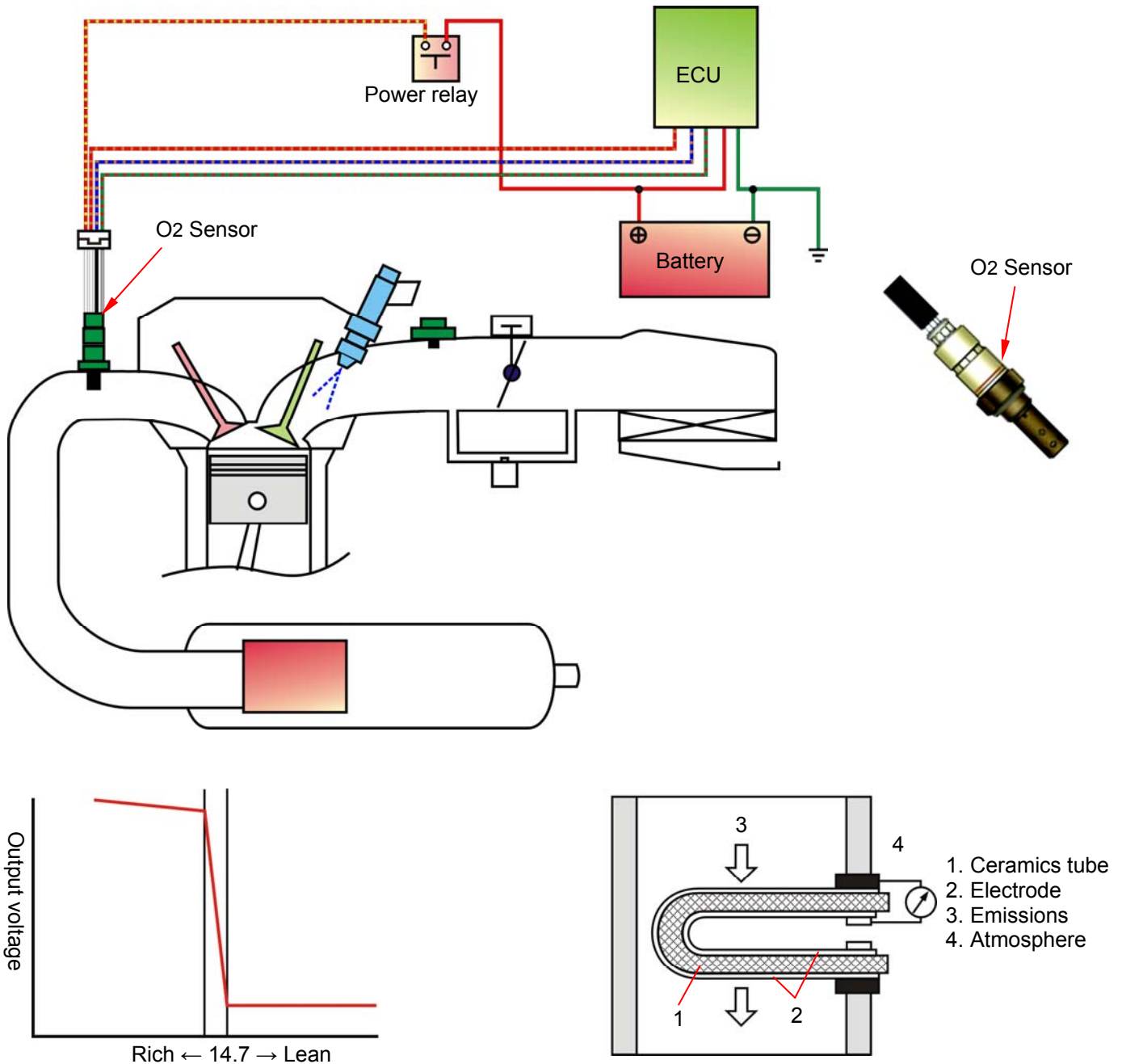

### Function

O<sub>2</sub> Sensor measures the proportion of oxygen in the exhaust gas, sending signals to ECU which adjusts the air-fuel ratio by changing the fuel injection time. If the proportion of oxygen is too low, it means the air-fuel mixture is rich, the concentration of HC & CO in the exhaust gas will rise. If the proportion of oxygen is too high, it means the air-fuel mixture is thin, thin air-fuel mixture will result in higher combustion temperature and higher NO<sub>x</sub> concentration.

1. O<sub>2</sub> Sensor outputs feedback signal to ECU which keeps the air-fuel mixture near the stoichiometric ratio approximately 14.6 and forms the closed loop control system.
2. When the air-fuel mixture is near the stoichiometric ratio, CO / HC / NO<sub>x</sub> are converted most efficiently.
3. O<sub>2</sub> Sensor heater resistance: 6.7 ~ 10.5 Ω
4. O<sub>2</sub> Sensor amendment in the voltage value: between 100 ~ 900 mV

#### Throttle position sensor (TPS)

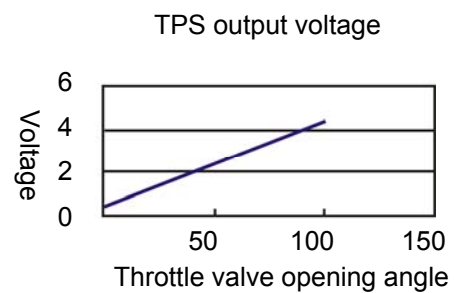
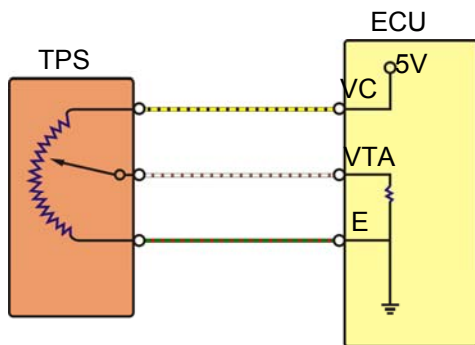
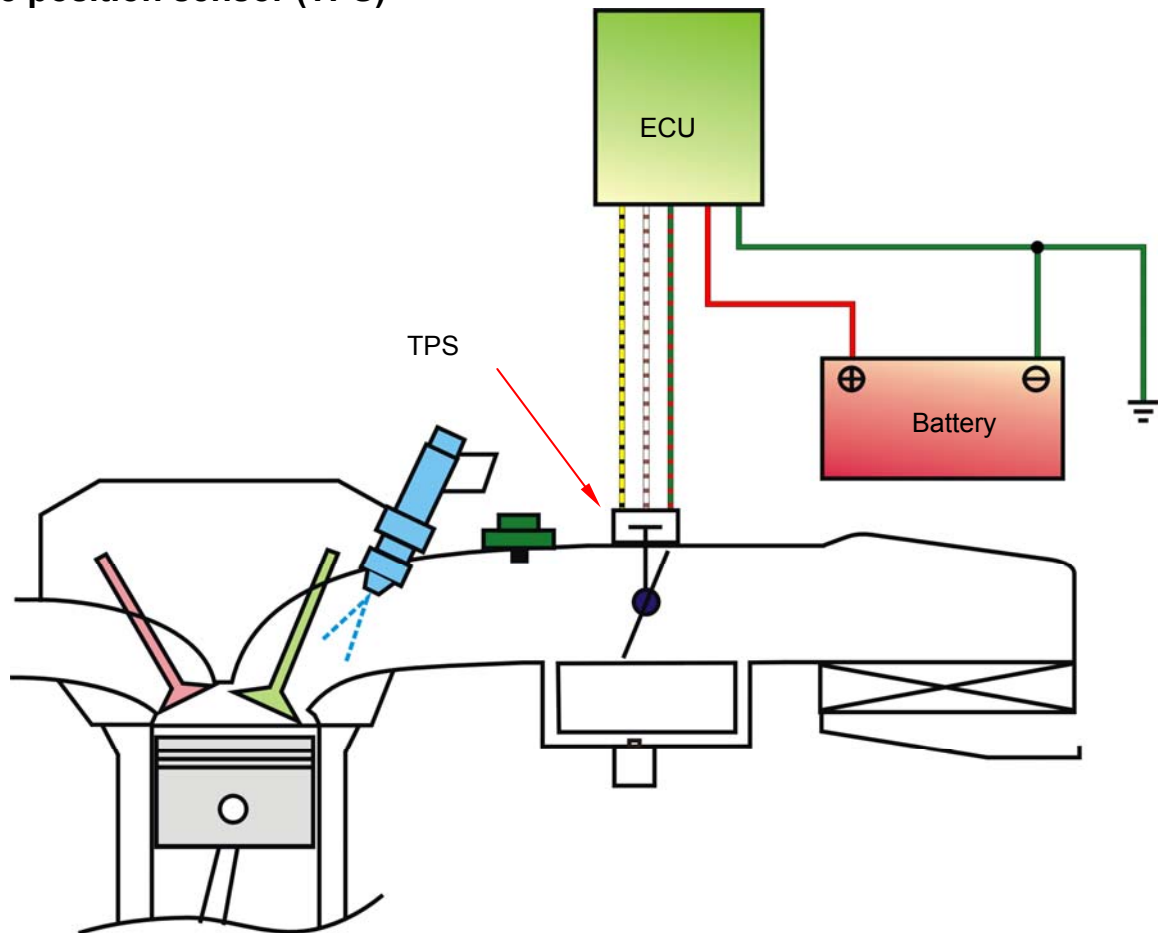

#### Basic Principle:

TPS is a rotary variable electric resistor. When it is rotated, both electric resistance and voltage value will change, determining the throttle position.

#### Function:

TPS identifies the throttle valve position and sends signal to ECU as reference of engine control.



### 3. Fuel Injection System



#### Idle speed control valve (ISC stepping motor)

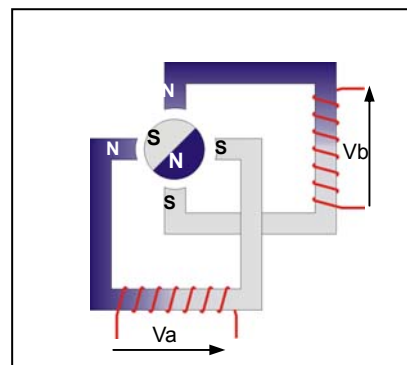
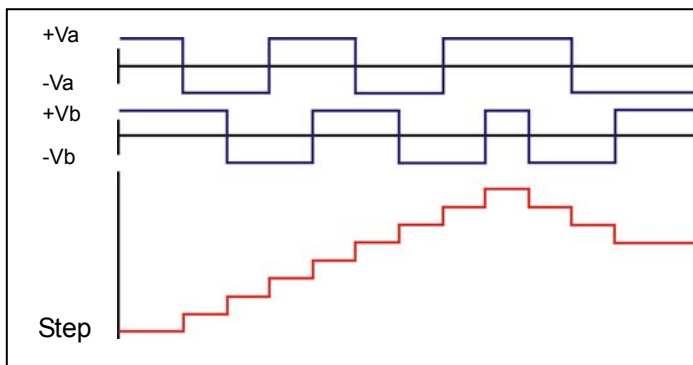
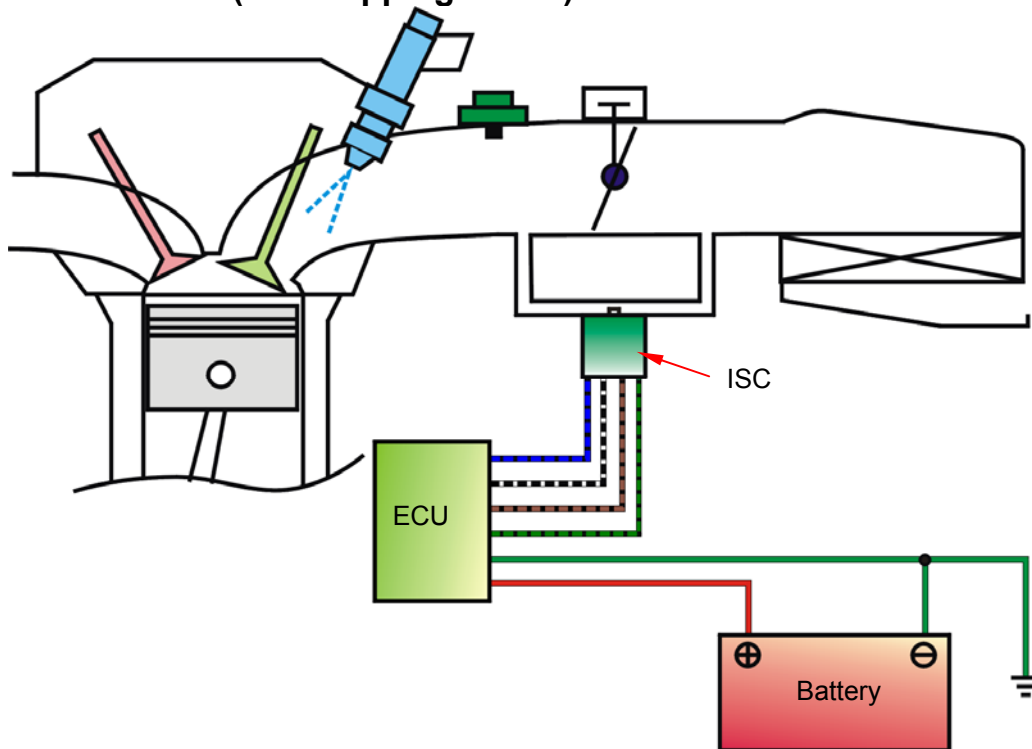

**Function:**

ECU controls ISC stepping motor to adjust the bypass intake air quantity and stabilize the idle speed.

#### Air injection solenoid valve (AISV)

**Function:** AISV introduces appropriate air quantity to reduce pollutant emission.

**Basic principle:** When the engine RPM and throttle opening are higher than the default value, ECU controls AISV opening or closure.

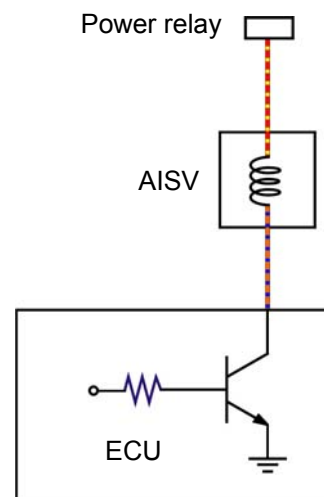
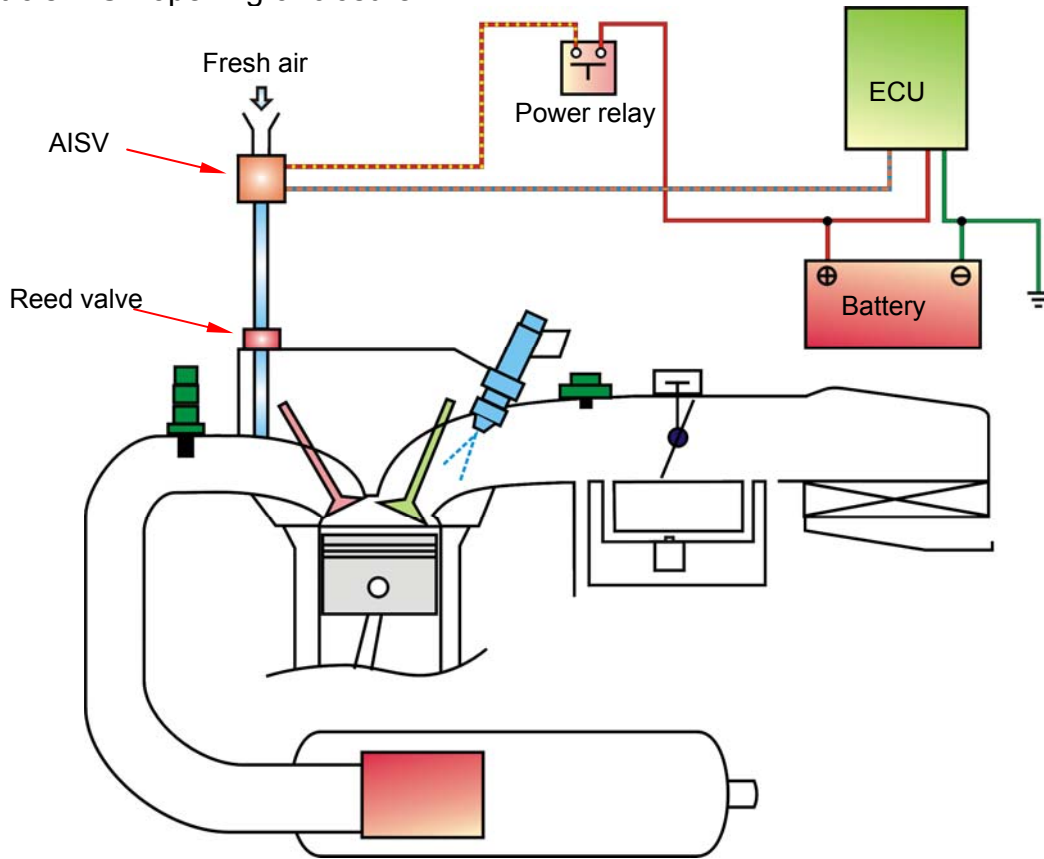

### Precautions in operation

#### General information

#### Warning

- Gasoline is a low fire point and explosive material. Always work in a well-ventilated place and flame is strictly prohibited when working with gasoline.
- Before dismantling fuel system parts, leak fuel out first, or grip the fuel pipe by using pliers to prevent fuel from splashing.

#### Caution

- Do not bend or twist the throttle cable. Damaged cable will lead to unstable driving.
- When disassembling fuel system parts, pay attention to O-ring position, replace with new one as re-assembly.

#### Method of releasing fuel pressure in fuel system:

After removing fuel pump relay, turn on the main switch, press start switch to start the engine till it stops to drain fuel in the fuel system.

#### Specification

Item	Specifications
Idle RPM	1650±100 rpm
Throttle handle free play	2~6 mm
Fuel pressure	294±6kpa (3.0kg/cm <sup>2</sup> )

#### Torque value

Engine temperature sensor: 0.74~0.88kgf-m

O<sub>2</sub> Sensor: 3.6~4.6kgf-m

#### Special Tools

Vacuum Gauge

Fuel Pressure Gauge

EFi System Diagnostic Scanner

Fuel Pipe Pliers

### EFi system components description

#### ECU(Electronic Control Unit)



#### Function Description:

- Powered by DC 8~16V, and has 36-pin socket on the unit.
- The hardware component consists of a 16-bit microcomputer that is its control center. It contains the functional circuit interface of engine condition sensing and the driving actuator for the fuel injector, fuel pump, as well as ignition coil.
- Its major software is a monitor strategy operation program that includes controlling strategy and self-diagnosis programs.

#### Testing Procedures:

1. Connect the diagnostic scanner to the diagnostic coupler on the vehicle.
2. Key-on but do not start the engine, confirm the connection of ECU and the diagnostic scanner.
3. Diagnostic scanner will automatically display Version "certification" of the screen.
4. Confirm the application model, version is correct or not.
5. Check if the fault codes exist.
6. Remove the fault codes.
7. Start engine and check the parameters shown on the diagnostic scanner.

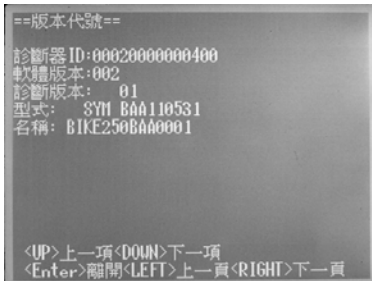

#### Detection judge:

- Fault codes can be read and cleaned, and the fault codes will not appear again after re-start.

#### Treatment of abnormal phenomena:

1. Can not connect→ First check whether the cartridge is correct and ECU is normal or not. Replace with new parts and recheck.
2. Unable to start→ ECU or relevant parts abnormal. Replace with new parts and recheck.
3. Fault codes appear→ ECU or relevant parts abnormal. Troubleshoot and recheck.

### Throttle body

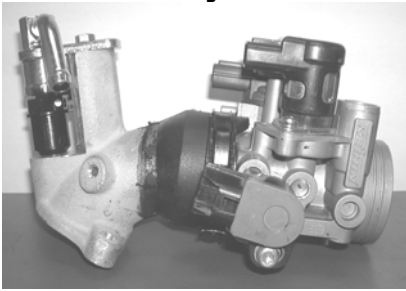

#### Function description:

- Throttle body is an inlet air flow regulating device (similar to the carburetor).
- Throttle valve pivot drives the throttle position sensor synchronously and makes ECU detect the throttle opening immediately.
- Throttle valve positioning screw has been adjusted and marked on the production line. Readjustment is not suggested.
- The ISC on throttle body functions to supply air making cold starting easier; after engine warmed up, the air channel will be reduced according to engine conditions.

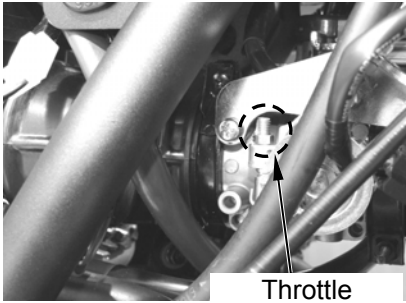

Throttle  
positioning  
screw

#### Treatment of abnormal phenomena:

- If all fuel injection associated components identified no fault, and other traditional engine components are also normal, the engine is still not smooth, please confirm if too much carbon deposits in the throttle body.
- If there is too much carbon deposit in the throttle body, please clean throttle body, and then adjust the injection system.

## MAP sensor

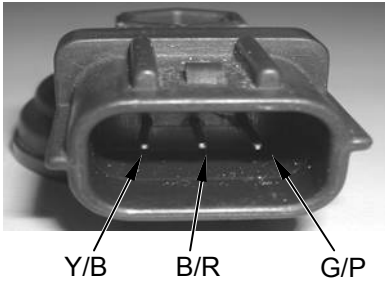
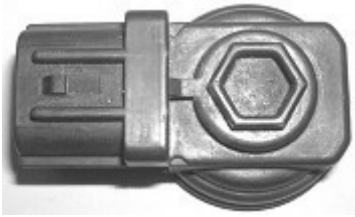

Working voltage measurement



Output voltage measurement

### Function description:

- Powered by 5V DC from ECU. It has 3-pin socket on the sensor. One terminal is for power, and one terminal is for signal output. And, the rest one is for grounding.
- The major component of the intake pressure sensor is a variable transistor IC. Its reference voltage is DC 5V, and output voltage range is DC 0~5V.
- It is a pressure-sensing sensor, and can measure the absolute pressure in intake process. It also conducts fuel injection quantity correction based on environmental position level.

Pin	Wire color	Function
Left	Y/B	5V voltage input
Center	B/R	Signal output
Right	G/P	Ground

### Testing Procedures

1. Connect inlet pressure sensor properly (using the probe tool).
2. Key-on but do not start the engine.
3. Use "voltage meter" DC stalls (DCV) to check inlet pressure sensor voltage.
4. Working voltage check:
  - Voltage meter negative access to the inlet pressure sensor third pin (Green/Pink)
  - Voltage meter positive access to the inlet pressure sensor first pin (Yellow / Black).
5. Confirm output voltage values:
  - Voltage meter negative access to the inlet pressure sensor third pin (Green/Pink)
  - Voltage meter positive access to the inlet pressure sensor second pin (Black/Red)

### ⚠ Caution

- The probe tool should contact the inner terminals to measure the correct value.

### Detection judge:

- Working voltage value: **5.0±0.1V**
- Output voltage values: **2.87±0.03V** (Conditions: Measure on level ground 101.3 kPa)

### ⚠ Caution

- The higher the elevation, the lower voltage will be measured.
- Sea-level atmospheric pressure = 1Atm = 101.3kPa = 760mmHg = 1013mbar

### Treatment of abnormal phenomena:

- MAP sensor damaged, or poor contact couplers.
- Check if the wire harness abnormal.
- If MAP sensor fails, replace with a new one and recheck output voltage.
- If ECU fails, replace with a new one and recheck output voltage.

## TA sensor



### Function Description

- Powered by 5V DC from ECU. It has 2-pin socket on the sensor. One terminal is for voltage output, the other is for grounding.
- The major component of TA sensor is a variable resistor of negative temperature coefficient
- Installed in the air filter, the resistor in TA sensor varies with temperature variation and sends voltage signals for ECU to calculate the intake air temperature; then, ECU adjusts injection time and ignition angle.



### Testing Procedures:

Resistance value measurement:

- Dismantled TA sensor connector.
- Use the "Ohmmeter" Ohm stalls to inspect sensor resistance.

### Detection judge:

Temperature(°C)	Resistance value(KΩ)
-20	18.8 ± 2.4
40	1.136 ± 0.1
100	0.1553 ± 0.007



Resistance value measurement

### Treatment of abnormal phenomena:

- Damaged TA sensor or poor connector contact.
- Check if the wire harness abnormal.
- If TA sensor possibly failed, it is suggested to replace with a new one.

## TPS

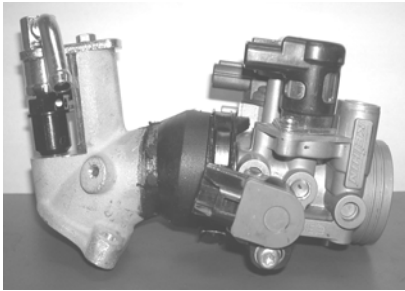

### Function description:

- Powered by 5V DC from ECU. It has 3-pin socket on the sensor. One terminal is for power, and one terminal is for voltage output. And, the rest one is for grounding.
- Its main component is a sophisticated variable resistor.
- Installed on the throttle body. While throttle is rotated, TPS senses the throttle position (opening) and sends voltage signals for ECU to judge the throttle position; then, ECU optimizes fuel injection and ignition timing.

Pin	Wire color	Function
Up	White/Brown	Signal output
Center	Yellow/Black	5V voltage input
Low	Green/Pink	Ground



Working voltage measurement



Throttle output signal measurement - close



Throttle output signal measurement - full

### Testing Procedures:

1. Working voltage can be measured while sensor coupler is connected (use probe tool) or removed (direct measurement).
2. Key-on but do not start the engine.
3. Use "voltage meter" DC stalls (DCV) to check voltage.
4. Working voltage check:
  - Voltage meter negative access to TPS third pin.(green/pink)
  - Voltage meter positive access to TPS second pin.(yellow/black)
5. Throttle output signal check: (using the probe tool)
  - Voltage meter negative access to TPS third pin.(green/pink)
  - Voltage meter positive access to TPS first pin.(white/brown)
  - Measure the output voltages of both full-throttle and close-throttle.

### ⚠ Caution

- The probe tool should contact the inner terminals to measure the correct value.

### Detection judge:

- Working voltage value: **5.0±0.1V**
- Close-throttle voltage value: **0.6±0.02V**
- Full-throttle voltage value: **3.77±0.1V**



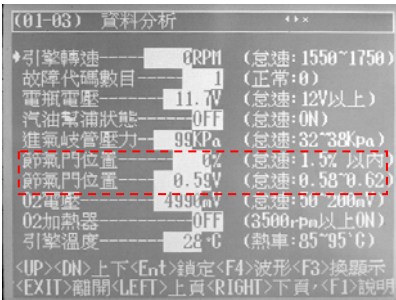

Throttle output signal measurement -close

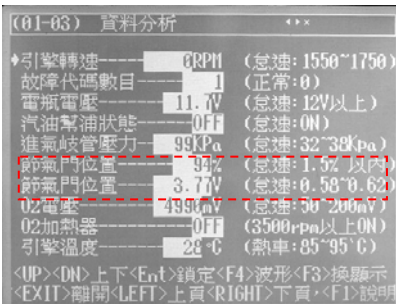

Throttle output signal measurement -full

Diagnostic tool can be used to check throttle output signals.

1. Connect the Diagnostic tool, key-on but do not start the engine.
2. Switch screen to “data analysis.”
3. Rotate the throttle and check the voltage.

### Treatment of abnormal phenomena:

- TPS damaged or coupler poor contact.
- Check if the wire harness abnormal.
- If TPS possibly failed, it is suggested to replace with a new one and check again.

### Warning

- It is prohibited to remove TPS from throttle body to conduct any test.

#### TW sensor:



#### Function Description:

- Powered by 5V DC from ECU. It has the two-pin socket on the sensor. One terminal is for voltage output, and the other terminal is for ground.
- The major component of TA sensor is a variable resistor of negative temperature coefficient
- Installed on the cylinder head, the resistor in TW sensor varies with temperature variation and sends voltage signals for ECU to calculate the intake air temperature; then, ECU adjusts injection time and ignition angle.



Resistance value measurement

#### Testing Procedures:

##### Resistance value measurement:

- Remove the TW sensor from the vehicle.
- Use the "Ohmmeter" Ohm stalls to inspect sensor resistance.

#### Detection judge:

Temperature (°C)	Resistance value (KΩ)
-20	18.8 ± 2.4
40	1.136 ± 0.1
100	0.1553 ± 0.007

#### Treatment of abnormal phenomena:

- Damaged TW sensor or poor connector contact.
- Check if the wire harness abnormal.
- If TA sensor possibly failed, it is suggested to replace with a new one.

## O2 Sensor



### Function Description:

- Powered by 8-16V DC from ECU. It has the four-pin socket on the sensor. One terminal is for heating power output, one for heating control, one for signal grounding, and one for signal.
- O2 sensor sends signal to ECU, and ECU control air / fuel ratio around 14.5 – 14.7 to form a close loop.
- When the air-fuel mixture is near the stoichometric ratio, CO / HC / NOx are converted most efficiently.

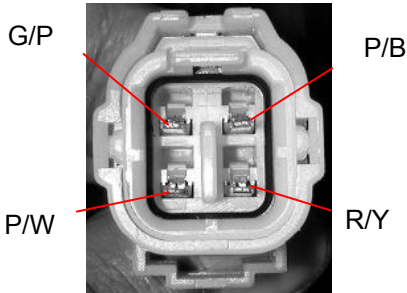

### Testing Procedures:

#### 1. Working voltage check

- Remove O2 sensor coupler from the wire harness.
- Key-on but do not start the engine.
- Use "voltage meter" DC stalls (DCV) to check the power supply of wire harness to the heating circuit of the O2 sensor.
- Working voltage check

Voltage meter negative access to the second pin of wire harness coupler. (pink/white)

Voltage meter positive access to the first pin of wire harness. (red/yellow)

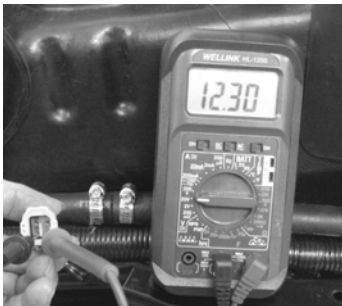

Working voltage check

#### 2. Resistance value check

- Remove O2 sensor coupler from the wire harness.
- Use the "Ohmmeter" Ohm stalls to inspect the heater sensor resistance.
- Resistance value check

Ohmmeter negative access to the second pin of O2 sensor. (white)

Ohmmeter positive access to the first pin of O2 sensor. (white)

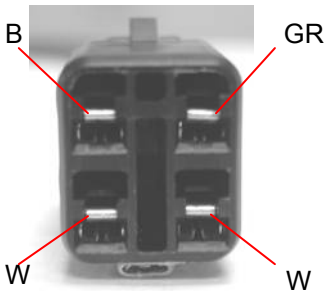

Resistance value check

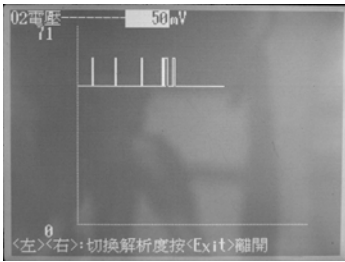

voltage changing condition.

### 3. Use of diagnosis tool to check O<sub>2</sub> sensor work situations

- Connect the Diagnostic tool, key-on and start the engine.
- Completely warm up the engine. (idle running for more than "5 minutes")
- Switch screen to "DATA STREAM 01/01", select "O<sub>2</sub> Sensor" project, turn the throttle to achieve 4500 rpm. Observe O<sub>2</sub> Sensor acting.
- Observe O<sub>2</sub> Sensor voltage changing condition.



### Detection judge:

- Working voltage: above 10V
- Resistance value: 6.7~10.5Ω
- That Observe O<sub>2</sub> Sensor voltage between 100 ~ 900 mV means pollution close loop control system is normal. However, it is abnormal, if the value is a fixed one.

### Treatment of abnormal phenomena:

- Damaged O<sub>2</sub> Sensor, damaged heater, or coupler poor contact.
- Check if the wire harness abnormal.
- If O<sub>2</sub> Sensor possibly failed, it is suggested to replace with a new one and check again.

## Rollover sensor

Normal



### Function description

- Rollover sensor controls power of the power relay coil and has three-pin socket.
- When the vehicle tilt angle is greater than 65 degrees, rollover sensor will be the implementation of ECU system power-off. At this time, to restart the engine, the main switch has to be turn on again.
- It is a safety device, when the vehicle rolls over, it will cut off power supply to ECU.

Rollover



### Testing procedures:

- Rollover sensor is an electronic control mechanism. It is unable to test while the sensor removed from the vehicle.
- In normal situation, key on, measure the voltage of white/brown and green/pink (ground) wire of ECU, then the condition of the rollover sensor can be judged.

### Detection judge:

**Voltage: Normal: 0.4~1.4V**

**Rollover: 3.7~4.4V**

### Treatment of abnormal phenomena:

Vehicle state vertical, no power supply to power relay or ECU.

- Rollover sensor internal short circuit or open circuit, or coupler poor contact.
- Check if the wire harness abnormal.
- If Rollover Sensor possibly failed, it is suggested to replace with a new one.

#### ISC(steping motor) :

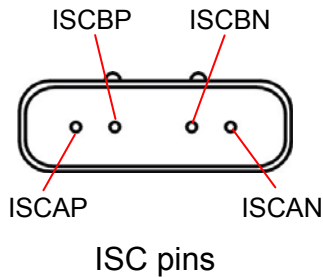
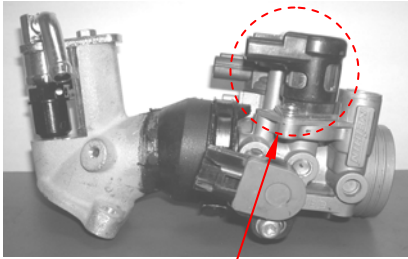

#### Function description:

- Powered by 8-16V DC from ECU. ISC has a four-pin socket.
- The 4-pin socket is composed of power supply and grounding circuits of two motors, ECU controls the acting of stepping motor by controlling the power supply and grounding circuit.
- Low-power-consuming DC motor drives the ISC. And the movement of ISC controls the opening of idle speed air channel, thus the idle speed of cold or warmed engine can be adjusted.

#### Testing Procedures

##### Resistance value check:

- Remove ISC coupler from throttle body. (It is okay to test while ISC installed on throttle body.)
- Use the "Ohmmeter" Ohm stalls to inspect the resistance of the two motor circuits.

A phase: ISCAP and ISCAN

B phase: ISCBP and ISCBN

##### Movement test (This test can only be conducted while ISC installed on throttle body.)

- Key-off.
- Touch ISC with hand.
- Key-on.
- Feel if the ISC moves.

#### Caution

- The movement test can only be conducted while ISC installed on throttle body.



Resistance value measurement of A phase



Resistance value measurement of B phase

#### Detection judge:

##### 1. Resistance value:

A phase:  $80 \pm 10\Omega$  (Environmental conditions: 15 ~ 25 °C)

B phase:  $80 \pm 10\Omega$  (Environmental conditions: 15 ~ 25 °C)

##### 2. Movement test

Test in accordance with the test procedure illustrated above, ISC will vibrate slightly or sounds continuous "da...da..."

#### Treatment of abnormal phenomena:

- Damaged ISC, or coupler poor contact.
- Check if the wire harness abnormal.
- If ISC is abnormal, it is suggested to replace with a new one and recheck its movement.

## Fuel pump



### Function Description:

- Powered by 8-16V DC from ECU. Fuel pump has a four-pin socket.
- The two pins are power supply and grounding. ECU controls the movement of fuel pump by controlling the power.
- Low-power-consuming DC motor (12V) drives the vane pump to keeps the pressure around  $294\pm 6\text{kPa}$  ( $3\text{kg/cm}^2$ ) in the fuel supply system.
- Fuel pump is placed inside the fuel tank. A fuel filter is installed on the inlet front to prevent foreign material entering and damaging the fuel pump and injector.



Fuel pump working voltage measurement

### Testing Procedures 1

Fuel pump working voltage check:

- Connect fuel pump coupler (use probe tools), or remove it to measure working voltage. (direct test)
- Key-on but do not start the engine.
- Use "voltage meter" DC stalls (DCV) to check fuel pump voltage.
- Working voltage check

Voltage meter negative access to the second pin of fuel pump. (green)  
Voltage meter positive access to the first pin of fuel pump. (black/orange)

### Caution

- While measuring fuel pump working voltage, if the engine is not started, ECU will cut off power supply to fuel pump within 3 seconds.



Fuel pump resistance measurement

### Detection judge 1

1. Working voltage: **above 10V**
2. Resistance:  **$1.5\pm 0.5\Omega$**
3. Fuel pressure:  **$294\pm 6\text{kPa}$  ( $3\text{kg/cm}^2$ )**

### Testing Procedures 2

Fuel unit resistance check

- Remove fuel unit coupler.
- Use the "Ohmmeter" Ohm stalls to inspect the resistance of the fuel unit. (yellow/white & green)



Fuel system pressure measurement

### Testing Procedures 3

Fuel pressure measurement

- Connect fuel gauge between fuel tank and injector.

#### Caution

- To measure fuel pressure, fuel hoses, injector side or fuel pump side, will be removed. After the measurement, please check if any fuel leaks.



Pressure measurement-injector side

### Detection judge 2

1. fuel pressure:  $294 \pm 6 \text{kPa}$  ( $3 \text{kg/cm}^2$ )

#### Treatment of abnormal phenomena:

1. Fuel pump internal circuit damaged, or coupler poor contact.
2. Clogged filter.
3. If fuel pump is abnormal, it is suggested to replace with a new one.
4. If fuel gauge is abnormal, it is suggested to replace with a new one.



Pressure measurement -fuel pump side



## Fuel injector



### Function Description:

- Powered by 8-16V DC from ECU. Fuel pump has a two-pin socket.
- Its major component is a high resistance voltage driven solenoid valve.
- The two pins are power supply and grounding. Fuel injector is controlled by ECU to decide the injection timing, and the injector pulse width.



Injector resistance measurement

### Testing Procedures:

1. Resistance test  
Use the "Ohmmeter" Ohm stalls to inspect the injector resistance.
2. Injector injection state check  
Remove injector fix bolts, but do not disconnect the coupler. Hold injector and injector cap with hand, no leak should happen. Key-on and start the engine; inspect the injecting state.

### Detection judge:

1. Resistance between the two pins:  $10.5 \pm 0.53 \Omega$
2. Injection state
  - Good fuel atomizing, with a clear scattering angle → judged as normal.
  - Injection-state resembles water drop, no obvious scattering angle → judged as abnormal.



good injection

### Treatment of abnormal phenomena:

1. Resistance NG→ abnormal injector, it is recommended to replace with a new one.
2. Abnormal injection state, reasons:
  - Clogged injector→ abnormal injector, it is recommended to replace with a new one.
  - Insufficient fuel pressure→ check fuel pressure, it is recommended to replace with a new one and recheck.



abnormal injection

### Warning

- Fuel is highly flammable and explosive. Work in a well-ventilated place, no flame or spark allowed.
- Properly store the fuel injected by injector while conducting test.

#### Transistor ignition coil

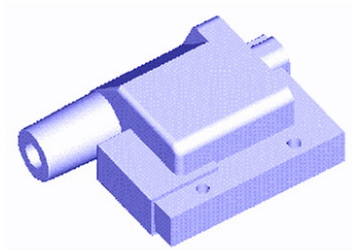

Primary circuit resistance measurement

#### Function Description:

- Powered by 8-16V DC from ECU. Fuel pump has a two-pin socket.
- The two pins are power supply and grounding. Its major component is a high conversion ratio transformer.
- The computer programmed ignition system receives the signals from the Crankshaft position sensor, Throttle position sensor, O2 Sensor, MAP sensor, Intake air temperature sensor, Engine coolant temperature sensor. Calculating the engine RPM, the 16-bit microcomputer determines the appropriate ignition timing, controls the ignition coil and triggers the spark plug This way can not only make the engine achieve the maximum power output, but also help improve fuel consumption rate.

#### Testing Procedures

Resistance measurement:

- Remove primary circuit coupler from ignition coil.(red/yellow & black/yellow)
- Use the "Ohmmeter" Ohm stalls to inspect the ignition coil resistance.

#### Detection judge:

- Ignition coil primary circuit:  $2.8\Omega \pm 15\%$
- Ignition coil secondary circuit: without cap  $9.0K\Omega \pm 20\%$  with cap  $14.0K\Omega \pm 20\%$

#### Treatment of abnormal phenomena:

1. Ignition coil internal short circuit or open circuit, or coupler poor contact.
2. If ignition coil is abnormal or dose not ignite, it is recommended to replace with a new one.

#### Crankshaft position / RPM sensor

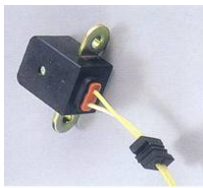
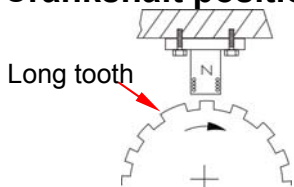

Resistance measurement

#### Function Description

- It does not need power supply, and has a two-pin plug.
- Its major component is a reluctance induction coil.
- The spacing of flywheel and sensor should be 0.7 to 1.1 mm.
- Magnetic induction sensor is the use of flywheel on the Gear (23 +1 long tooth) rotary cutting induction coil changes in the magnetic field sensor with the inductive voltage signal for ECU judgment, calculated at the engine speed and crankshaft position, and with a most appropriate time of fuel injection and ignition control.

#### Testing Procedures

Resistance measurement:

- Remove CPS coupler. (blue/yellow & green/white)
- Use the "Ohmmeter" Ohm stalls to inspect the CPS resistance.

#### Detection judge

- Resistance:  $120\Omega \pm 20\%$

#### Treatment of abnormal phenomena

1. CPS internal circuit damaged, or coupler poor contact.
2. Check if the wire harness abnormal.
3. If CPS is abnormal, it is suggested to replace with a new one.

## AISV



### Function Description:

- AISV has two-pin socket, one is for power supply and the other is for grounding.
- AISV acts while RPM under 3500.
- While idling, ECU controls AISV movements by controlling its solenoid valve grounding circuit.

### Testing Procedures

Resistance measurement:

- Use the "Ohmmeter" Ohm stalls to inspect the AISV resistance.

### Detection judge

Resistance:  $22 \pm 2\Omega$  (20~30°C)

### Treatment of abnormal phenomena

- AISV internal short circuit or open circuit, or coupler poor contact.
- Check if the wire harness abnormal.
- If CPS is abnormal, it is suggested to replace with a new one.



AISV working voltage measurement



Resistance measurement

## EFI system circuit

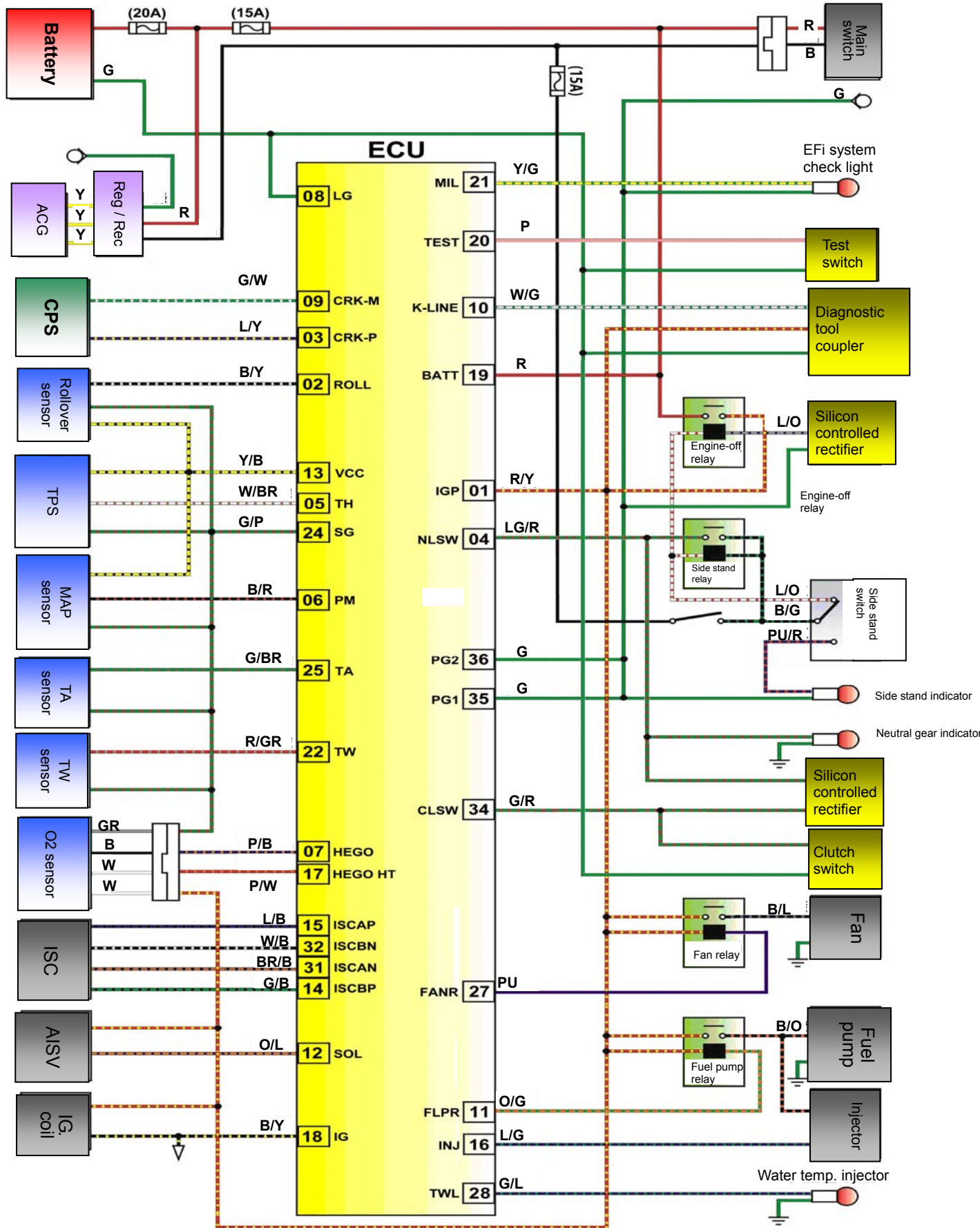

### 3. Fuel Injection System



#### ECU pin configuration

(on ECU)

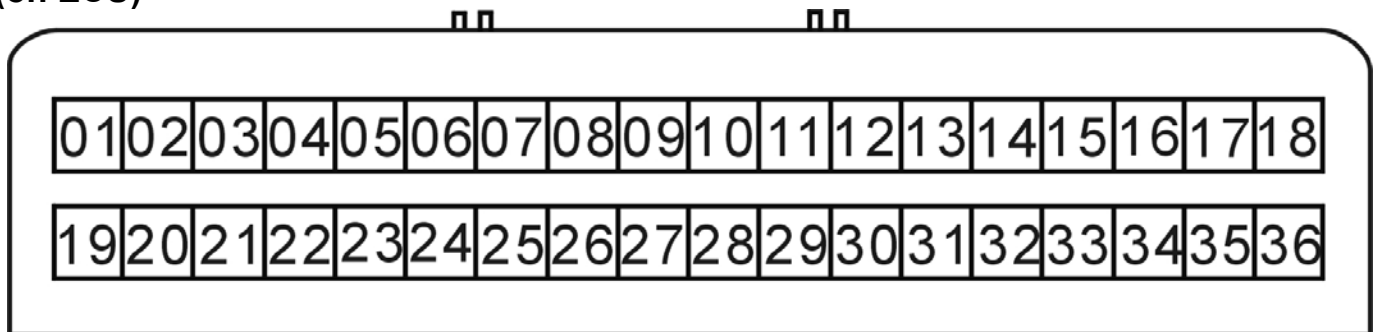

#### ECU Pin Note

Pin NO.	Wire color	Pin code	Note	Pin NO.	Wire color	Pin code	Note
01	R/Y	IGP	Drive components Power +	19	R	BAT	ECU power +
02	B/W	ROLL	Rollover sensor signal input	20	P	TEST	Test switch signal (A/D)
03	L/Y	CRK-P	Crankshaft pos. Sensor+	21	Y/G	MIL	Warning Lights O/P
04	LG/R	NLSW	Neutral gear switch signal	22	R/GR	TW	Eng. Water Temp. Sensor (A/D)
05	W/BR	TH	Throttle position [A/D]	23	-	-	No use
06	B/R	PM	Manifold Press. SNSR I/P [A/D]	24	G/P	SG	Sensor ground
07	P/B	HEGO A/D	O <sub>2</sub> Sensor [A/D]	25	G/BR	TA	Intake air temperature sensor (A/D)
08	G	LG	ECU ground	26			No use
09	G/W	CRK-M	Crankshaft pos. Sensor-	27	PU	FANR	Cooling fan drive
10	W/G	K-LINE	Sequence transmission signal output / input	28	G/L	TWL	Water temp. drive
11	O/G	FLPR	Fuel pump relay O/P	29	-	-	No use
12	O/L	SOL	AISV O/P	30	-	-	No use
13	Y/B	VCC	Sensor power + (DC 5V)	31	BR/B	ISCAN	Step motor A phase power -
14	G/B	ISCBP	Step motor A phase power +	32	B/W	ISCBN	Step motor B phase power -
15	L/B	ISCAP	Step motor B phase power +	33			No use
16	L/G	INJ	Fuel injector O/P	34	G/R	CLSW	Clutch switch signal
17	P/W	HEGO HT	O <sub>2</sub> Sensor heater ground	35	G	PG1	Drive components ground
18	B/Y	IG	Ignition coil O/P	36	G	PG	Drive components ground

## Troubleshooting

### EFi Circuit inspection

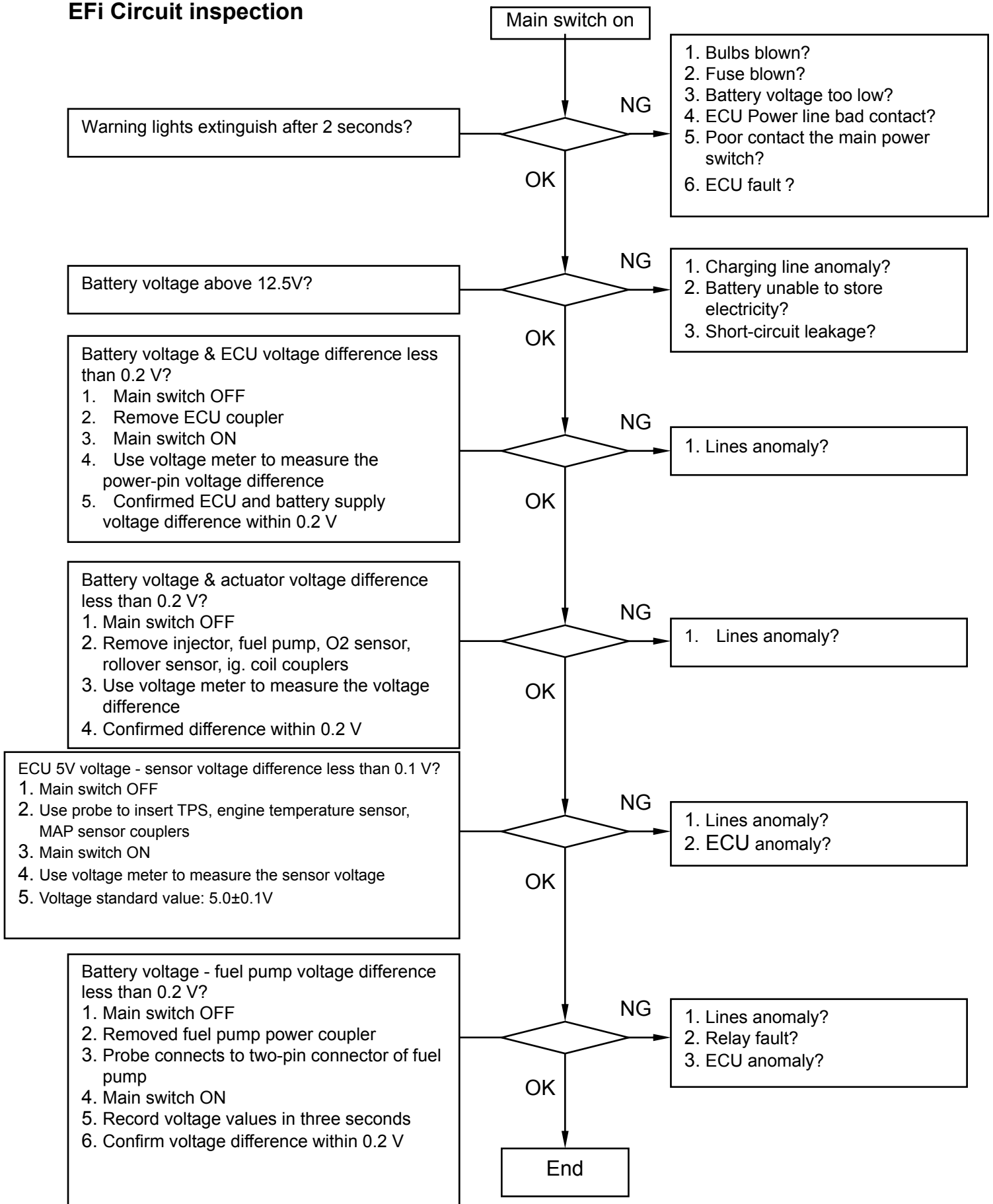

## Difficult or unable to start engine

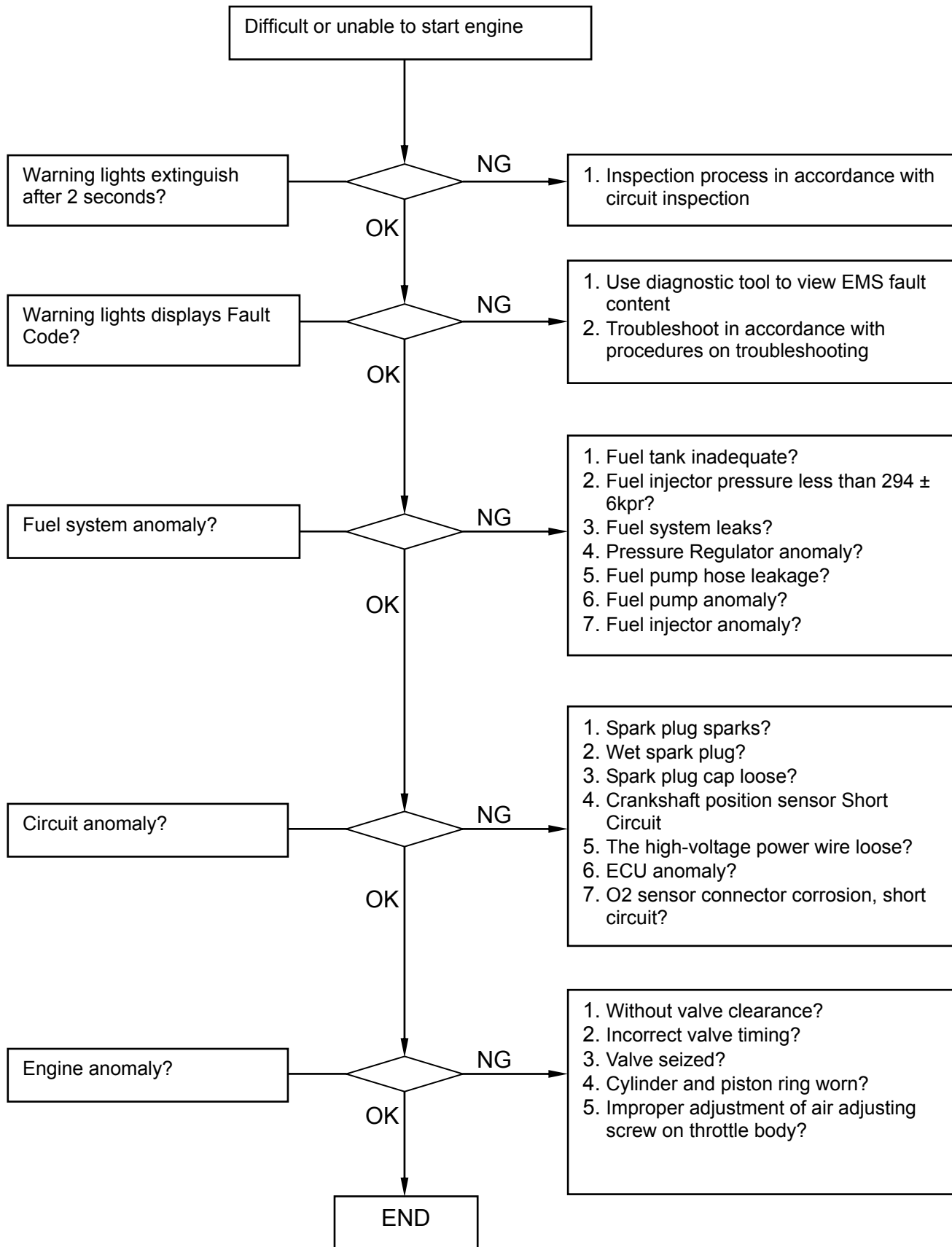

#### Idle flameout diagnosis

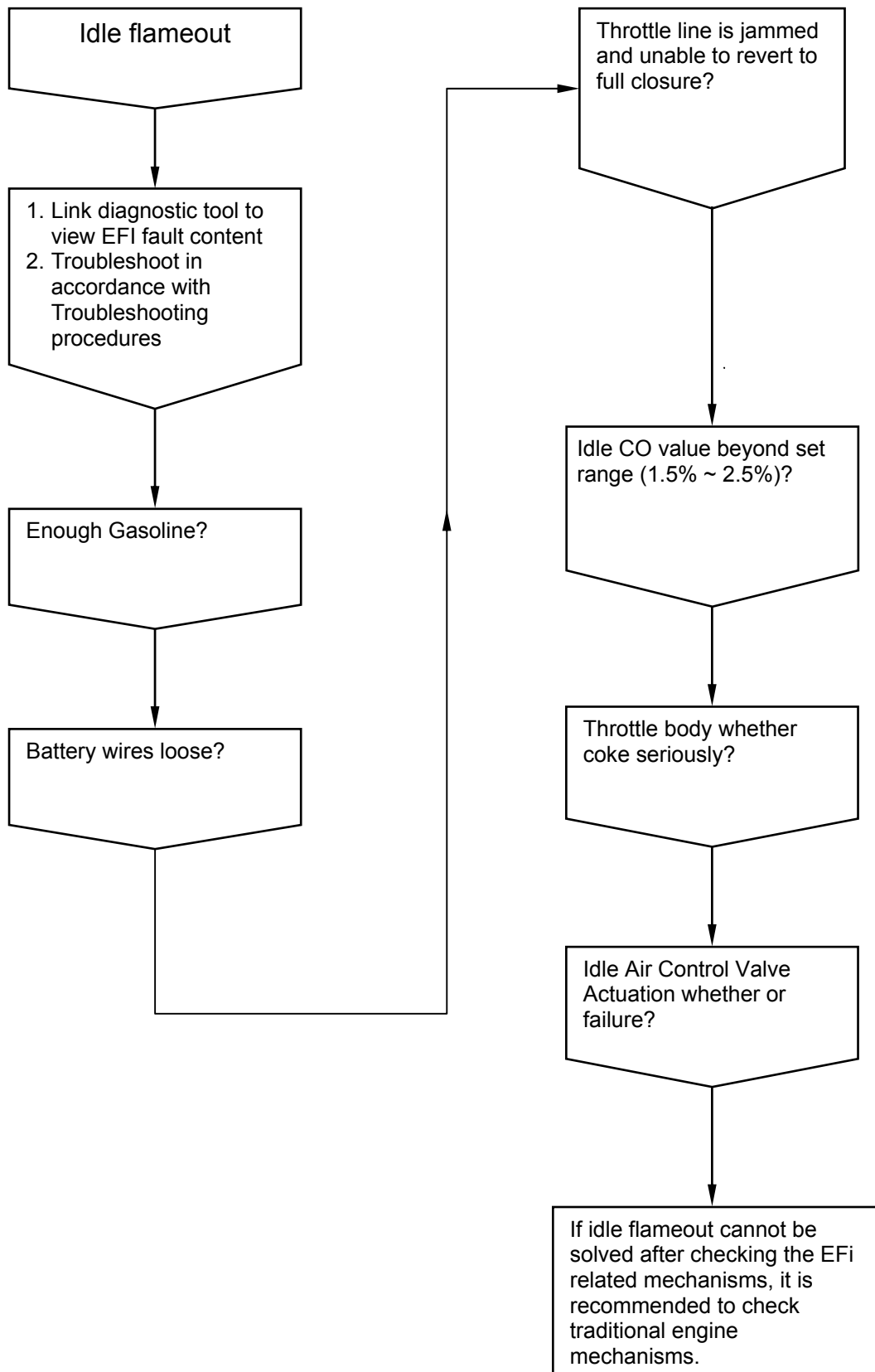



## CO value revised anomaly

In principle, system equipped with O<sub>2</sub> Sensor, the CO value needs no adjustment. If CO value deviates from normal range, please check if O<sub>2</sub> Sensor or other mechanisms is abnormal.

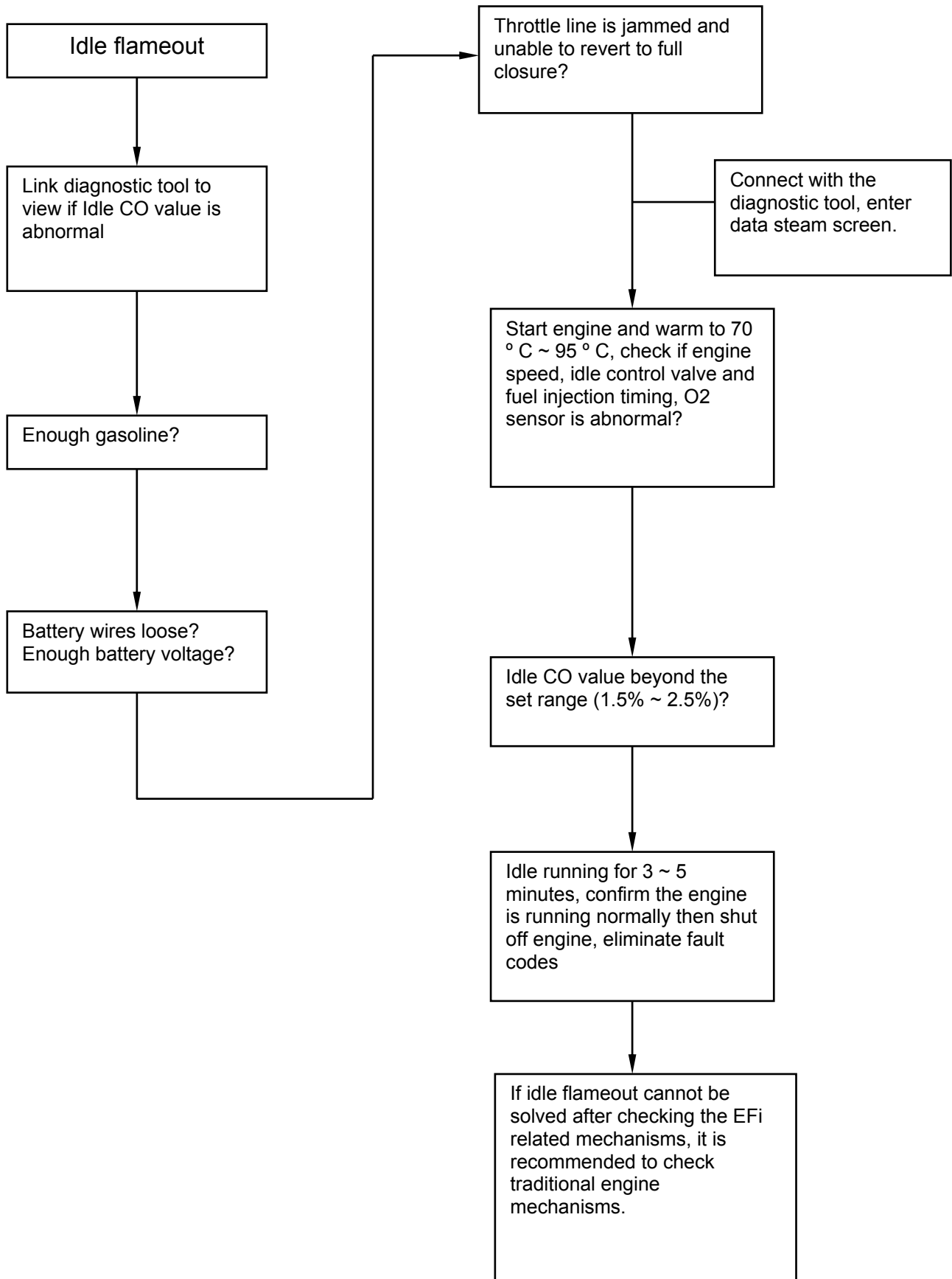

#### Intergrated troubleshooting procedure

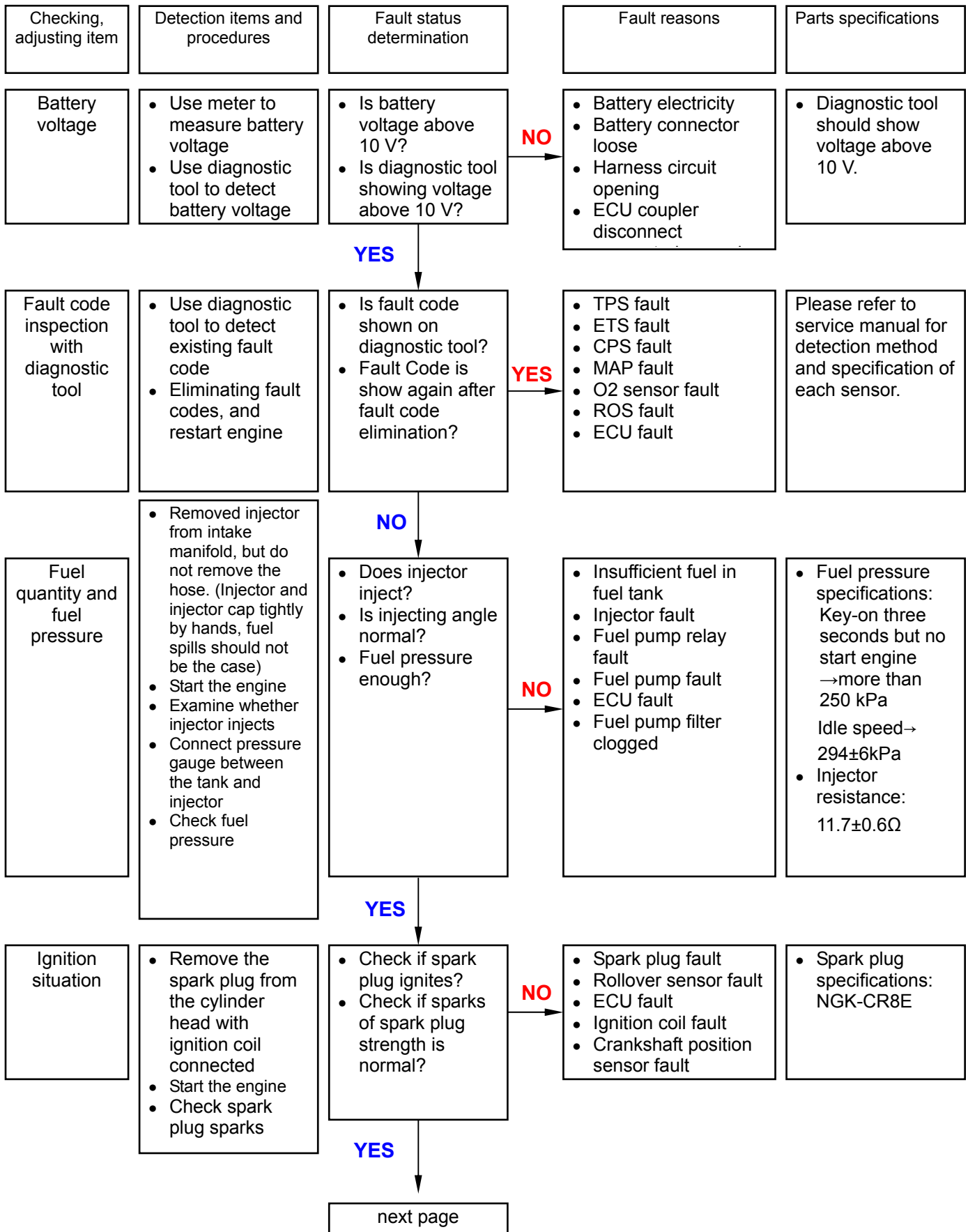

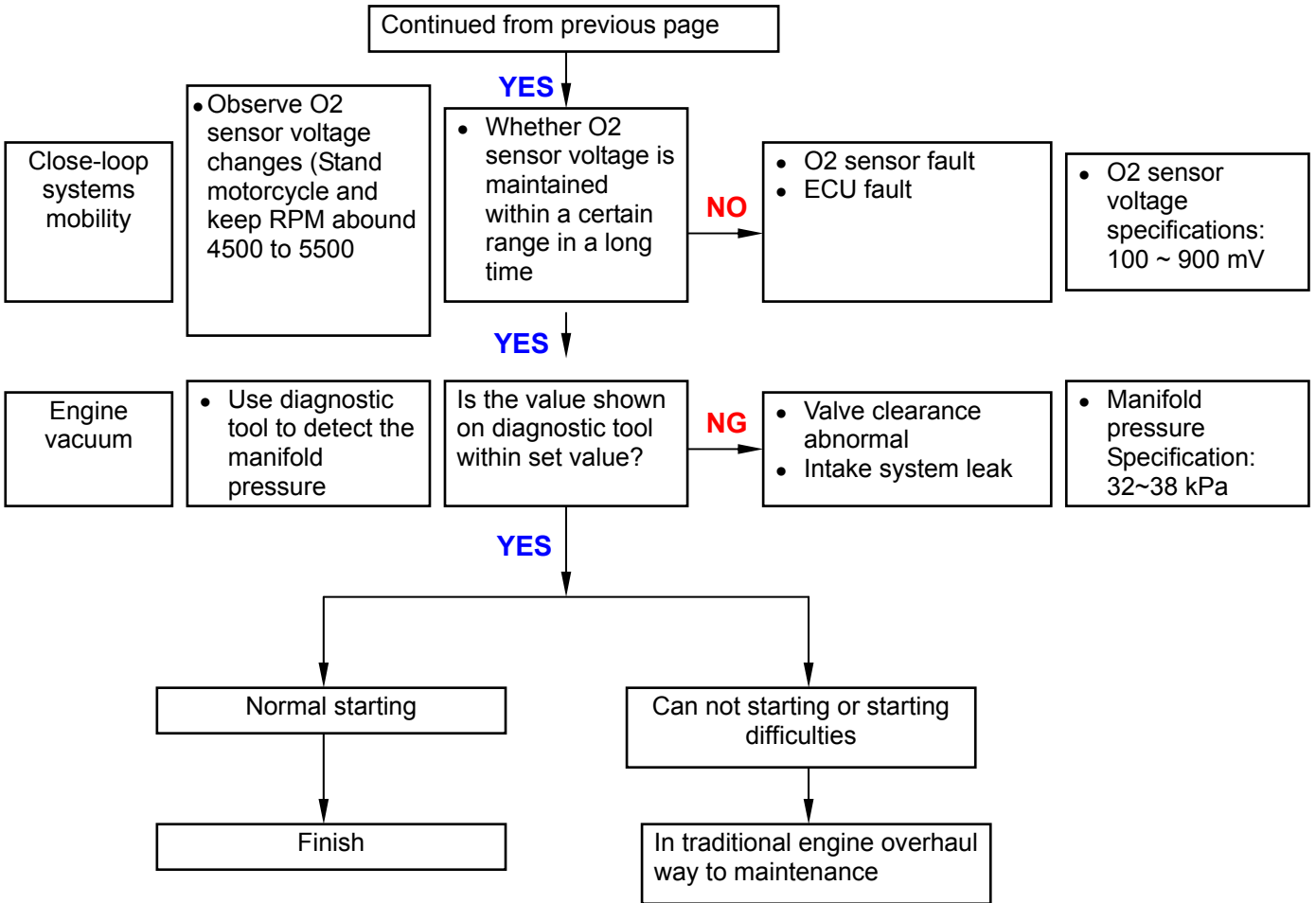

#### Fuel tank

##### Removal

Remove the rear seat.  
Remove the front seat (bolt x2).

Release the fuel pipe band, fuel pump coupler, EEC tube.

##### Caution

- Make sure the fuel is not too much in the fuel tank. Pump out the fuel if necessary.

Remove the fuel tank rear bolt.

Remove the fuel tank.

##### Caution

- If the fuel tank is damaged or leaking, replace with new one.

##### Installation

Install in the reverse order of removal.

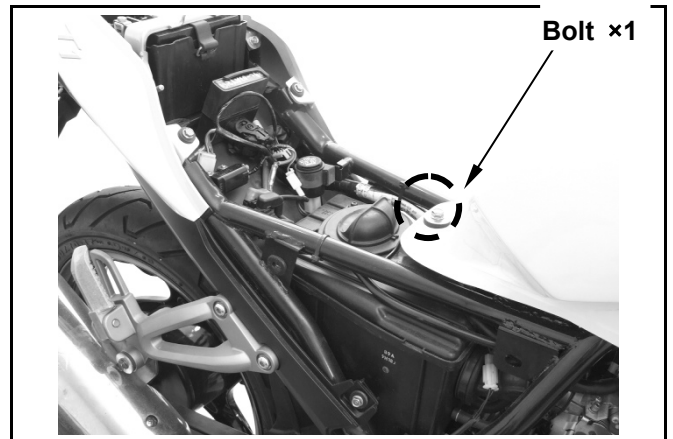
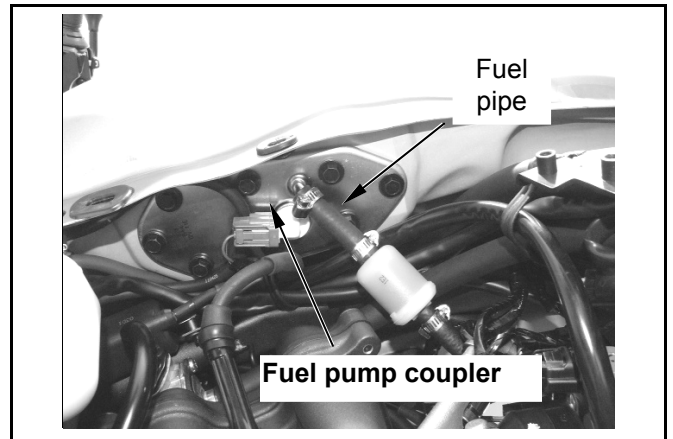
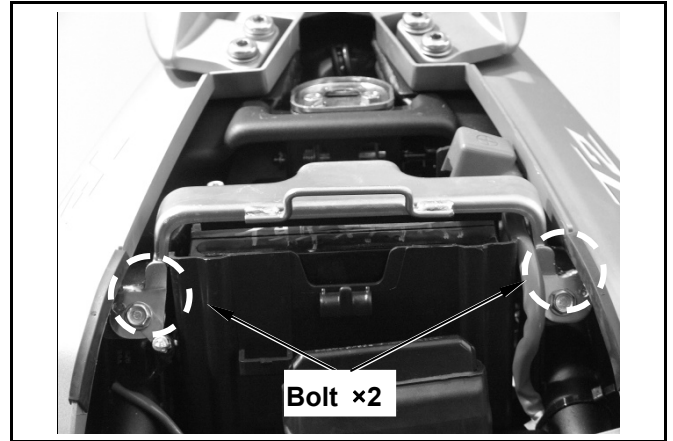

### 3. Fuel Injection System



#### Fuel pump

##### Removal

- Remove right and left turning signals and seat.
- Drain fuel from fuel tank.
- Remove EEC system and fuel hoses.
- Remove power wire of fuel pump and fuel unit.
- Remove fuel tank.
- Remove fuel pump. (boltX8) 。

##### Fuel pump removal

- Remove fuel pump power wire.
- Loosen the clamp.

Remove fuel hose by using fuel hose removal pliers.

**Tool number: SYM-1768110**

Remove the fuel pump.

#### Caution

- Check if the gasket worn or damaged.  
Replace with new one if it is abnormal.

Check if the rubber hose fastened well.  
Check if fuel filter contaminated or clogged. Replace with new one if it is too dirty.

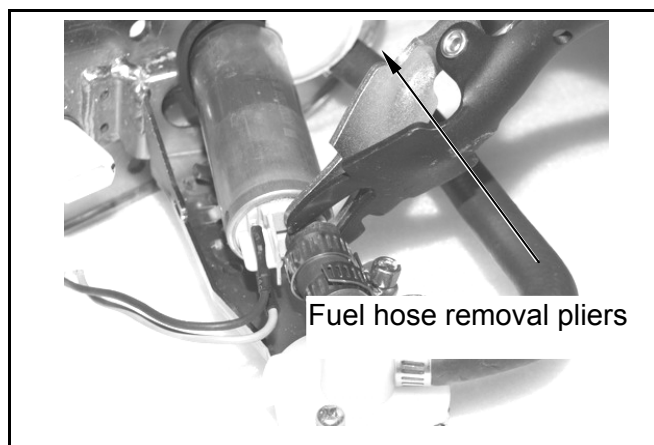
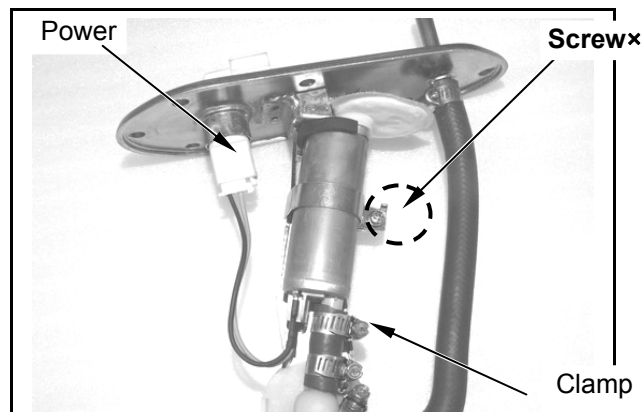
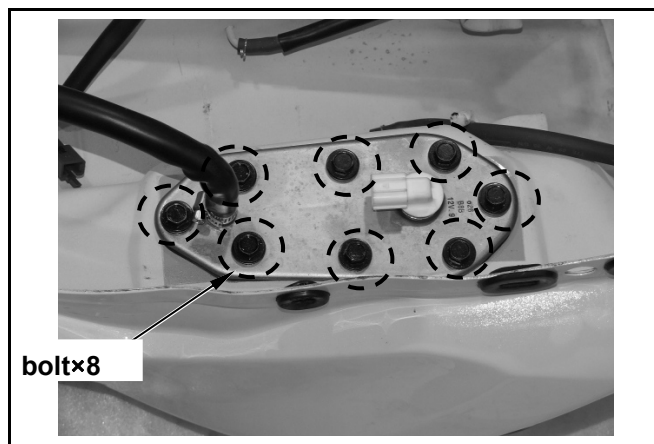

#### Fuel Unit

Remove fuel unit screw. (screw×4)  
Remove fuel unit.

#### Installation

Install in the reverse order of removal.

#### ⚠ Caution

- Do not bend the fuel unit float arm.
- Do not fill out too much fuel in the tank.
- Apply glue to the screw before installation.
- Replace the washer with new one.

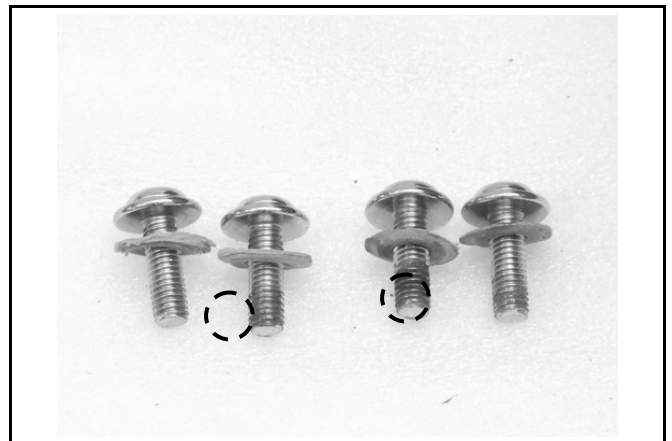
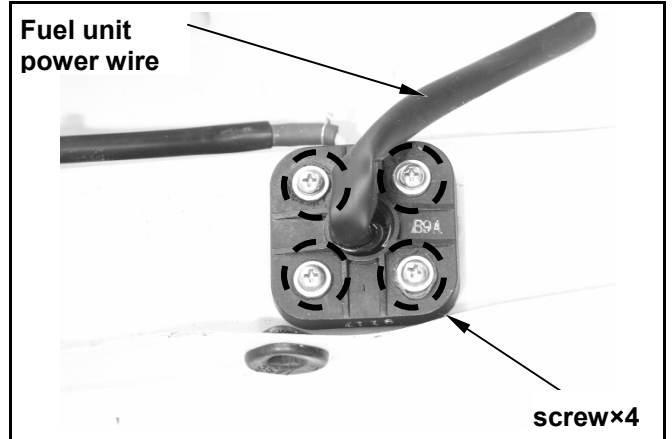

#### Air cleaner

Remove the rear and front seat.  
Remove the air cleaner cover (bolt x4).

Remove the air cleaner element.

#### ⚠ Caution

- The air cleaner is paper-base; please blow it clean with compressed air. Don't use water or other solvent
- Replace it with new one if the dirt cannot be removed.

#### Installation

Install in the reverse order of removal.

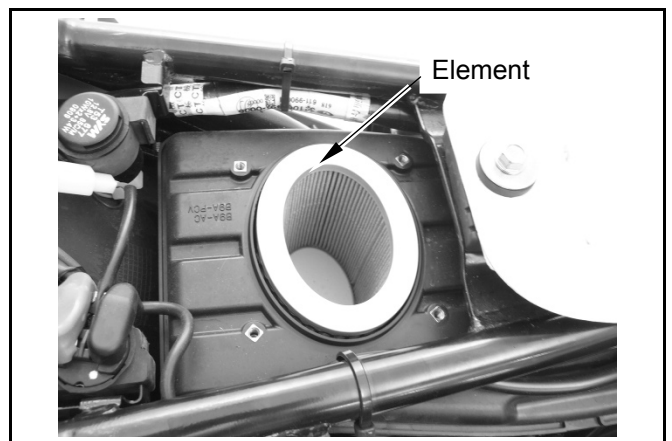
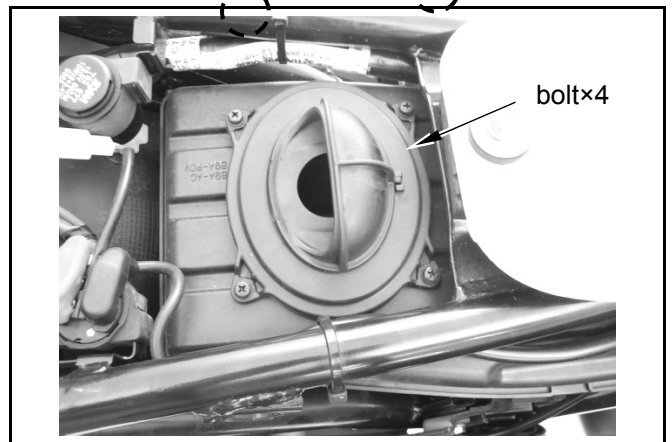

### EFi system diagnosis methods

When wrong signal occurs in motorcycle injection system, causing engine abnormal function or unable starting, the check light at the meter will be lighting to inform drivers to carry out maintenance.

While overhauling, diagnostic tool or meter flashing lighting identification can be applied to carry out fault detection.

After troubleshooting maintenance, the check light will be off, but ECU will record the fault code. Thus, fault code should be eliminated. There are two methods of fault elimination, one is using diagnostic tool and the other is manual elimination.

### Using diagnostic tool

Connect diagnostic tool and the test switch and check in accordance with diagnostic tool using method. When EFi system or EFi parts malfunction is detected, replace or correct parts according to information shown on the screen. After maintenance, fault code should be eliminated, or the fault will exist in ECU.

### Manual inspection

Use jumping wire (wire or paper clips, etc.) to ground test switch, check light on the meter will be flashing, meaning that the injection system or parts is abnormal. When no diagnostic tool is available, the long and short flashings can be used to tell the fault cause.

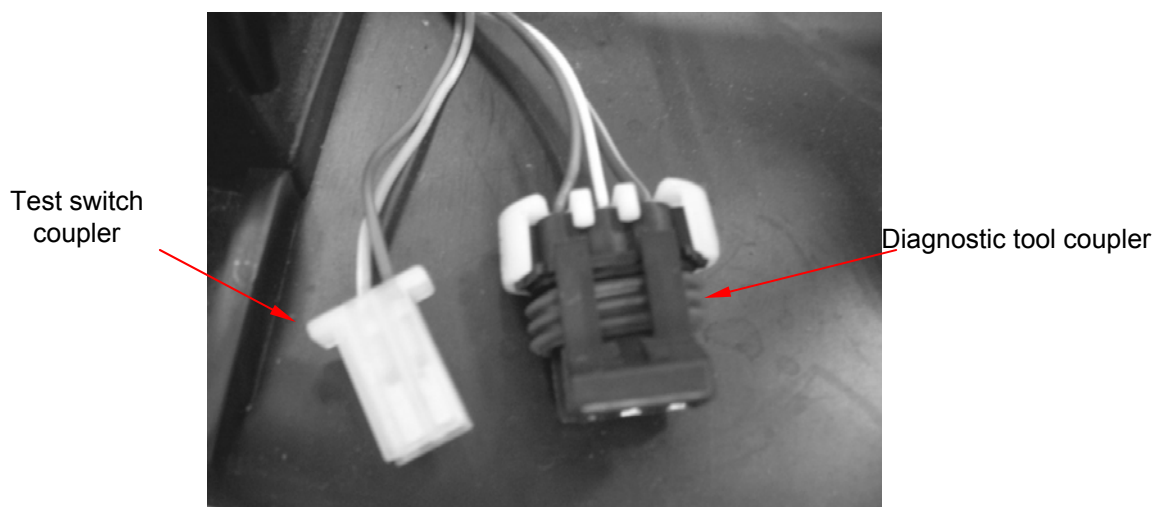

Diagnostic tool coupler and test switch coupler

#### Check light fault codes differentiation

##### Check light flashing mode

When there is no diagnostic tool for fault detection, wire jump the test switch and identify the fault by check light flashing and then correct the fault.

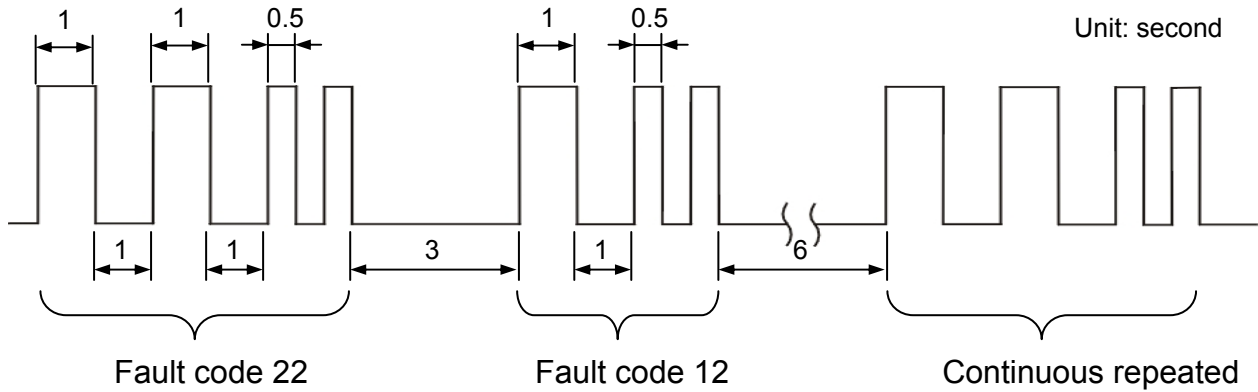

##### Fault Code manual elimination procedure:

Fault code can be eliminated manually without using diagnostic tool, procedures as following:

1. Main switch OFF
2. Wire jump the test switch.
3. Full throttle and do not release.
4. Main switch ON
5. Continue step 3 and 4 for five seconds, five seconds later the check light will flash twice quickly. Then the fault code will be eliminated.
6. Remove the jumping wire.

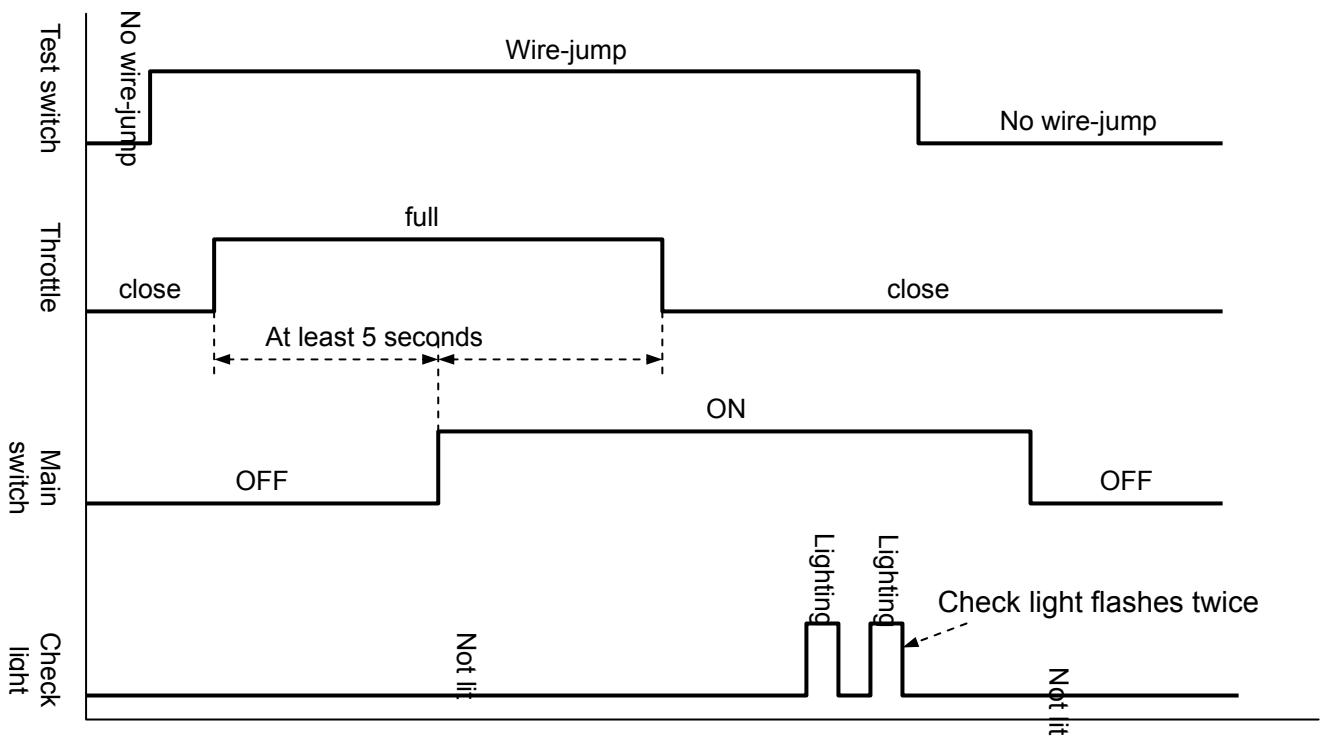



### 3. Fuel Injection System



#### Fault codes and sensors table

No.	Fault	Fault Description	Parts Inspection
1	0120	Throttle position sensor fault	TP Sensor and wire
2	0105	Manifold absolute pressure sensor fault	MAP sensor and wire
3	0115	Engine temperature sensor fault (water)	TW Sensor and wire
4	0110	Intake air temperature sensor fault	TA Sensor and wire
5	1630	Roll over sensor fault	Roll over sensor and wire
6	0130	O <sub>2</sub> sensor fault	O <sub>2</sub> Sensor and wire
7	0201	I N J #1 fault	Injector and wire
8	0351	IG #1 fault	Ignition coil and wire
9	0230	Fuel pump fault	Fuel pump and wire
10	0135	O <sub>2</sub> sensor heater fault	O <sub>2</sub> Sensor and wire
11	1505	ISC Idle speed control motor fault	ISC stepping motor and wire
12	1410	Exhaust 2 <sup>nd</sup> air control solenoid valve fault	AISV and wire
13	0335	Crankshaft position sensor fault	Crankshaft position sensor and
14	1205	MAP wire fault	MAP sensor and wire
15	0603	EEPROM fault	EEPROM
16	0480	Fan relay fault	Fan relay and wire

#### Fault code and check light flashing lighting identification table

No.	Fault codes	Fault Description	Check light	Check light flashing state	Parts Inspection
1	0120	Throttle position sensor fault	Lighting	long 0 , short 6	Throttle position sensor and wire
		Fault detection procedures Please refer to the "EFI System components description" throttle position sensor (TPS) chapter			
2	0105	Manifold Absolute Pressure sensor fault	lighting	long 0 , short 9	MAP sensor and wire
		Fault detection procedures Please refer to the "EFI System components description" manifold Absolute Pressure sensor (MAP) chapter			
3	0115	Engine temperature sensor fault (water)	lighting	long 1 , short 2	Engine temperature sensor and wire
		Fault detection procedures Please refer to the "EFI System components description" engine temperature sensor (WPS) chapter.			
4	0110	Intake temperature sensor fault	lighting	long 1 , short 3	Intake temperature sensor and wire
		Fault detection procedures Please refer to the "EFI System components description" intake temperature sensor (TAS) chapter.			
5	1630	Roll over sensor fault	lighting	long 1 , short 5	Roll over sensor and wire
		Fault detection procedures Please refer to the "EFI System components description" Roll over sensor chapter.			
6	0130	O <sub>2</sub> sensor fault	lighting	long 1 , short 7	O <sub>2</sub> Sensor and wire
		Fault detection procedures Please refer to the "EFI System components description" O <sub>2</sub> sensor chapter.			
7	0201	I N J #1 fault	lighting	long 3 , short 3	Injector and wire
		Fault detection procedures Please refer to the "EFI System components description" fuel injector chapter.			
8	0351	IG #1 fault	lighting	long 3 , short 7	Ignition coil and wire
		Fault detection procedures to adhere to the traditional way			
9	0230	Fuel pump fault	lighting	long 4 , short 1	Fuel pump and wire
		Fault detection procedures Please refer to the "EFI System components description" fuel pump chapter.			
10	0135	O <sub>2</sub> sensor heater fault	lighting	long 4 , short 5	O <sub>2</sub> Sensor and wire
		Fault detection procedures Please refer to the "EFI System components description" O <sub>2</sub> Sensor chapter.			
11	1505	ISC motor fault	lighting	long 4 , short 9	Step motor and wire
		Fault detection procedures Please refer to the "EFI System components description" idle speed control valve (ISC) chapter.			
12	1410	Exhaust 2 <sup>nd</sup> air solenoid valve fault	lighting	long 5 , short 4	2 <sup>nd</sup> air control valve and wire
		Fault detection procedures Please refer to the "EFI System components description" 2 <sup>nd</sup> air solenoid valve chapter.			
13	0335	Crankshaft position sensor fault	lighting	long 6 , short 6	Crankshaft position sensor and wire
		Fault detection procedures Please refer to the "EFI System components description" Crankshaft position sensor chapter.			
14	1205	MAP sensor wire fault	lighting	long 6 , short 8	MAP sensor wire
		Fault detection procedures Please refer to the "EFI System components description" MAP sensor chapter.			
15	0603	EEPROM fault	Not lit	long – , short –	EEPROM
		This fault Please direct replacement ECU			
16	0480	Cooling fan relay fault	lighting	long 4 , short 3	Cooling fan relay and wire
		Fault detection procedures Please refer to the "EFI System components description" cooling fan relay chapter.			

### 3. Fuel Injection System



#### Troubleshooting table

Test items Abnormal phenomena		Comprehensive testing program							Parts		
		Power voltage	Fuel press.	Ignition state	Engine vacuum	Injection state	closed-loop control system	Fault Code Detection	ECU	Throttle position sensor	Engine temp. sensor
Start state	Can't start	○	○	○	○	○		○	○		
	Difficult to start	○	○		○			○		○	○
Idle state	Without idle			○	○	○		○		○	○
	Idle not smooth					○	○	○	○	○	
	RPM NG							○	○		
	CO NG		○			○	○	○	○		
Acceleration	Not smooth		○	○	○	○		○	○	○	○
	Inability and slow		○	○	○	○		○	○	○	○
Flameout	Idle flameout				○			○			
	Acceleration flameout							○	○		
Related parts		Roll over sensor	Fuel pump	Ignition coil	Inlet pipe	Injector	O2 sensor				
		Power relay	Fuel pressure adjustment valve	Spark plug	Cylinder head	Fuel pump	Secondary air injection solenoid valve				
		Main switch	Fuel pump relay		MAP sensor	Fuel pressure adjustment valve					
		Battery	Fuel filter								

Note: 1. Integrated test motorcycle, according to the "Comprehensive Maintenance list" implementation.  
 2. Spare parts, according to the "EFI System components description" implementation.

#### Comprehensive maintenance list

NO	Maintenance Project	Testing Procedures	Test items	Determine benchmarks	Fault reasons
1	<b>Power and voltage</b>	<ul style="list-style-type: none"> <li>Use meter direct measurement battery voltage</li> <li>Use diagnosis tool detection of battery voltage</li> </ul>	<ul style="list-style-type: none"> <li>Battery voltage</li> </ul>	<ul style="list-style-type: none"> <li>Battery voltage = 10V Above</li> </ul>	<ul style="list-style-type: none"> <li>Battery electricity</li> <li>Battery connector loose</li> <li>Harness circuit opening</li> <li>ECU coupler not connected properly</li> </ul>
2	<b>Fuel pressure</b>	<ul style="list-style-type: none"> <li>Use fuel pressure gauge, connected in series between the injector and the Pressure Regulating Valve</li> <li>Main switch ON, but not start engine</li> <li>Check fuel pressure</li> <li>Start engine (idle)</li> <li>Check change of the fuel pressure</li> <li>throttle several rotation</li> <li>check to the change of fuel pressure again</li> </ul>	<ul style="list-style-type: none"> <li>Open the main switch, but not to start the engine of pressure</li> <li>Pressure in idle</li> <li>Rotating throttle, situation of pressure changes</li> </ul>	<ul style="list-style-type: none"> <li>Open main switch, but not start: pressure = 250kPa (Stable value)</li> <li>Idle state: pressure = 294±6kPa (Beating situation from top to bottom)</li> <li>rotation throttle moment: pressure = 294±6kPa (Slightly beating)</li> </ul>	<ul style="list-style-type: none"> <li>Fuel not enough</li> <li>Security switch not disarm</li> <li>Ruel pump relay fault</li> <li>Ruel pump fault</li> <li>Injector fault</li> <li>1. ECU fault</li> </ul>
3	<b>Ignition state</b>	<ul style="list-style-type: none"> <li>The spark plug removed from the cylinder head, but the power lines still ring</li> <li>Start engines or use for the diagnosis tool of output View spark plug ignition conditions</li> </ul>	<ul style="list-style-type: none"> <li>Spark plug specifications</li> <li>Whether the spark plug ignition</li> <li>Spark plug sparks whether it is normal strength</li> </ul>	<ul style="list-style-type: none"> <li>Specifications: NGK-CR8H</li> <li>Ignition conditions: With traditional engines found ways</li> </ul>	<ul style="list-style-type: none"> <li>Spark plug fault</li> <li>Roll over sensor fault</li> <li>ECU No. 5 pin fault</li> <li>Ignition coil fault</li> <li>Crankshaft position sensor fault</li> </ul>
4	<b>Engine vacuum</b>	<ul style="list-style-type: none"> <li>Diagnosis tool to detect the use of</li> </ul>	<ul style="list-style-type: none"> <li>Manifold pressure of diagnosis tool</li> </ul>	<ul style="list-style-type: none"> <li>Manifold pressure =32~38kPa</li> </ul>	<ul style="list-style-type: none"> <li>Valve clearance abnormal</li> <li>Intake system leak</li> </ul>
5	<b>Injection state</b>	<ul style="list-style-type: none"> <li>The injector removed from the throttle body, but not dismantle pipeline</li> <li>Main switch ON, but not start engine</li> <li>Investigation the injector it's leaking fuel?</li> <li>Once again start engines or use for the diagnosis tool of output function</li> <li>Check injector fuel injection and the injection situation</li> </ul>	<ul style="list-style-type: none"> <li>Open the main switch, but did not start engine the injection situation</li> <li>Injector state when start</li> </ul>	<ul style="list-style-type: none"> <li>Not started, injector not leaking fuel</li> <li>In started, the injection state must show fan shape</li> </ul>	<ul style="list-style-type: none"> <li>Security unit is configured not disarm</li> <li>Fuel pump relay fault</li> <li>Fuel pump fault</li> <li>Injector fault</li> <li>ECU fault</li> </ul>
6	<b>Closed - loop control system</b>	<ul style="list-style-type: none"> <li>Use of diagnostic tool observation O2 Sensor voltage changes</li> </ul>	<ul style="list-style-type: none"> <li>Stable condition, sensor voltage variation (Idle continued 5 minutes later to measurement)</li> </ul>	<ul style="list-style-type: none"> <li>Idle stable condition: O2 Sensor voltage = 50 ~ 200mV (Show from top to bottom beating phenomenon)</li> </ul>	<ul style="list-style-type: none"> <li>O2 Sensor fault</li> <li>ECU fault</li> </ul>
7	<b>Fault Code Detection</b>	<ul style="list-style-type: none"> <li>Use of the diagnosis tool existing fault-detection code or historical Fault Code</li> <li>Elimination of the implementation of fault codes, check can be eliminated</li> <li>Once again start engine</li> <li>Check fault is it happen again</li> </ul>	<ul style="list-style-type: none"> <li>Diagnosis tool of the fault code is it can be eliminated</li> <li>Start again, the fault is it will happen again</li> </ul>	<ul style="list-style-type: none"> <li>Without any residual Fault Code</li> <li>If residual Fault Code, according to the "Fault Code Maintenance Form" implementation of troubleshooting</li> </ul>	<ul style="list-style-type: none"> <li>throttle position sensor fault</li> <li>Engine temperature sensor fault</li> <li>Intake temperature sensor fault</li> <li>Manifold pressure sensor fault</li> <li>O2 Sensor fault</li> <li>Crankshaft position sensor fault</li> <li>ECU fault</li> <li>Roll over sensor fault</li> </ul>

#### Notes:

- Fuel pressure gauge connected between the fuel tank and injector, open the main switch to repeatedly shut down, fuel system makes pressure stability.
- Injector and injector cap tightly by hands, fuel spills should not be the case.

Mechanism Diagram .....	4-1	Clutch Disassembly.....	4-5
Precautions in Operation.....	4-2	Clutch Inspection.....	4-6
Troubleshooting .....	4-3	Clutch Installation.....	4-7
Engine Oil .....	4-4	Oil Pump.....	4-9
Engine Oil Strainer Cleaning.....	4-4	Gear Shift Linkage Mechanism.....	4-11

## Mechanism diagram

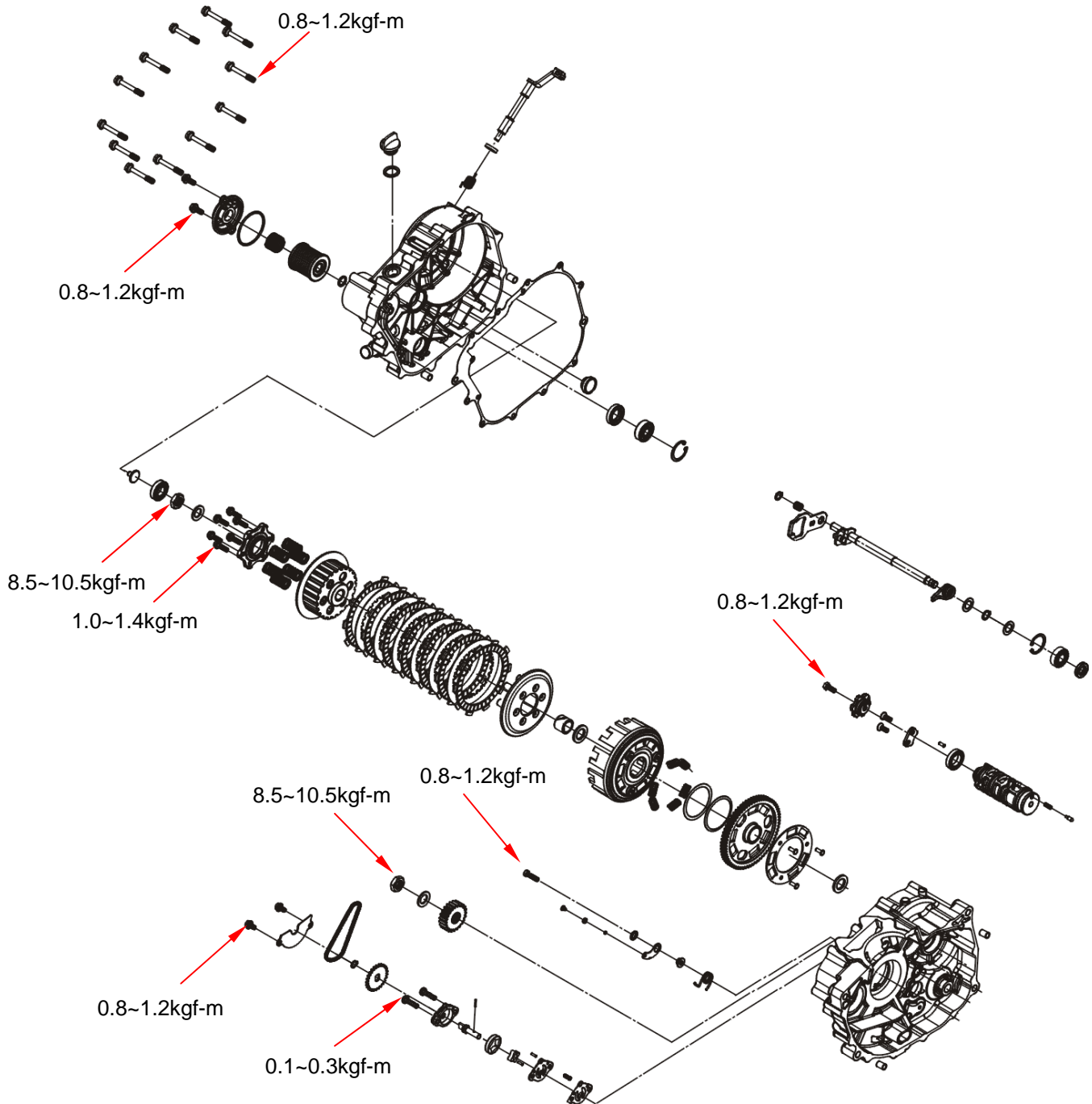

### Precautions in Operation

#### General information

- This chapter covers the engine oil pump and the oil exchange, also the disassembly and the shifting linkage is covered. All these operations can be done while the engine is still on the bike.

#### Specification

##### Engine oil quantity :

Full disassembly : 1700 c.c.

Regular maintenance : 1500 c.c.

Recommended engine oil viscosity:

SAE 10W-30

(The Bramax series oil is recommended)

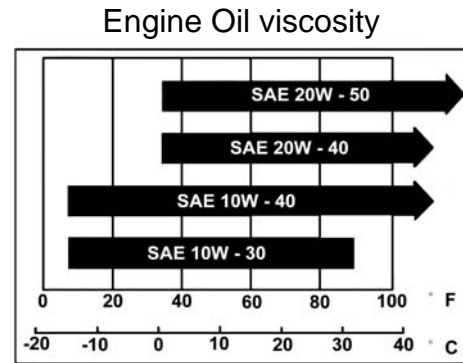

Measurement: mm

Item		Standard	Service Limit
Oil pump	Clearance between inner rotor and outer rotor	0.15	0.20
	Clearance between outer rotor and the pump body	0.15~0.20	0.25
	Rotor to pump cover clearance	0.04~0.09	0.12
Clutch	Lever free play	10~20	-
	Spring free length	44.65~44.80	41.70
	Friction disk thickness	3.00	2.50
	Clutch plate warp	-	0.20

#### Torque value

Oil pump cover bolts: 0.8~1.2kgf-m  
 Oil pump screw: 0.7~1.1kgf-m  
 Primary drive gear nut 8.5~10.5kgf-m

R. Crank case bolts: 0.8~1.2kgf-m  
 Clutch fix nut 8.5~10.5kgf-m  
 Clutch lifter plate bolt 1.0~1.4kgf-m

#### Special tools

### Troubleshooting

#### Insufficient engine oil

- Oil leaks
- Valve guides or seals worn out
- Worn piston rings

#### Insufficient oil pressure

- Insufficient oil amount
- Clogged oil strainer, oil route, oil tubes
- Abnormal oil pump

#### Engine oil dirty

- Engine oil is not exchanged periodically.
- Cylinder head gasket damaged
- Worn piston rings

#### Clutch slips when accelerating

- Insufficient clutch free play
- Worn clutch disks
- Weak clutch springs

#### Unable to disengage the clutch; or the bike trembles while clutch disengaged

- Excessive clutch free play settings
- Warped clutch plates

#### Excessive clutch lever pulling force

- insufficiently lubricated clutch cable
- Damaged clutch cable
- Clutch lifter mechanism damaged

#### Hard to shift gear

- Excessive clutch free play settings
- Twisted or bent shifting forks

#### Gearshift pedal won't return

- Broken or weak return spring
- Bent shift spindle

#### Gear jumps out

- Broken stopper arm spring
- Bent shift spindle

### Engine oil

Turn off the engine; park the motorcycle on level surface with main stand. Check oil level 3-5minutes later.

Check oil quantity from window, if oil level is near lower limit, fill in the recommended oil to upper limit.

### Exchange engine oil

#### Caution

- Drain oil when the engine is fully warmed up, so the oil can be drained completely.

Place an oil basin under the bike, and remove oil drain bolt.

Check if the washer damaged, replace when necessary.

Fill in new engine oil after installing oil drain bolt.

**Torque value : 3.5~4.5kgf-m**

### Engine oil strainer cleaning

Remove engine oil strainer cap.

Remove engine oil strainer and spring.

Clean oil strainer with compressed air.

Check if O-ring can be re-used. If it's damaged, please replace with a new one

Install engine oil strainer and spring.

Install engine oil strainer cap.

**Torque value : 1.3~1.7kgf-m**

Fill in engine oil (oil viscosity SAE 10W-30)

Recommended using Bramax series oil.

Install dipstick, run the engine for several minutes. Then turn off engine, and check oil level again.

Check if engine oil leaks.

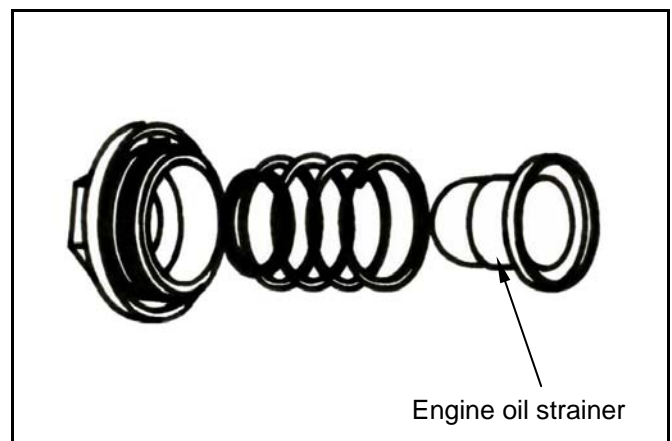
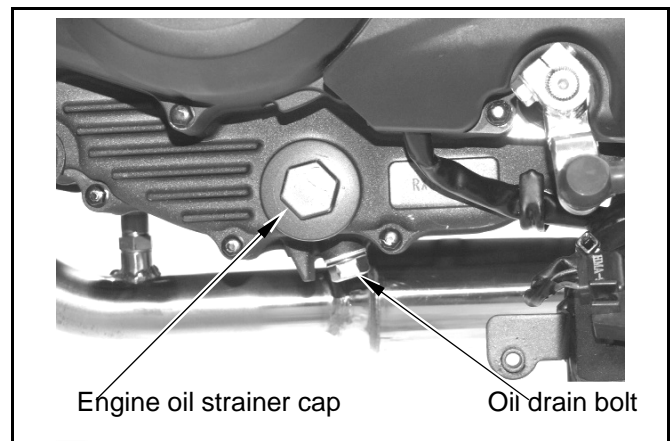
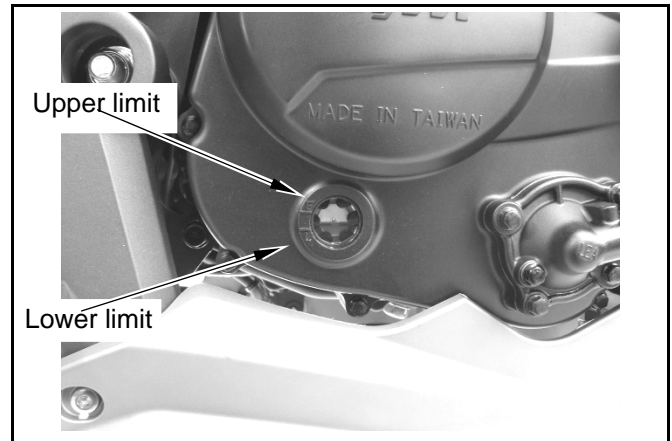



### Clutch disassembly

Drain all engine oil.  
Remove clutch cable.

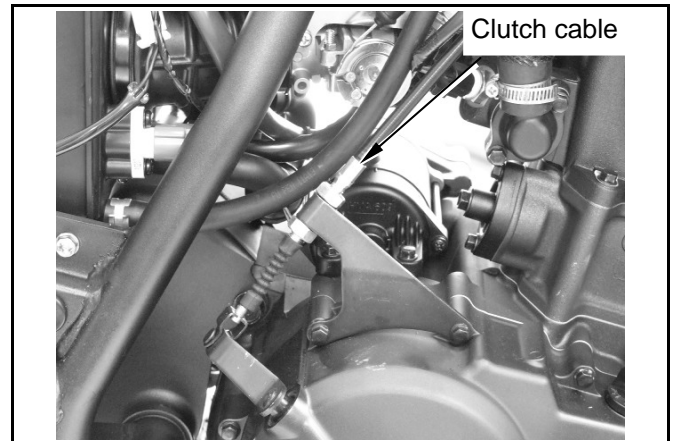

Remove right crankcase cover(boltx12)。

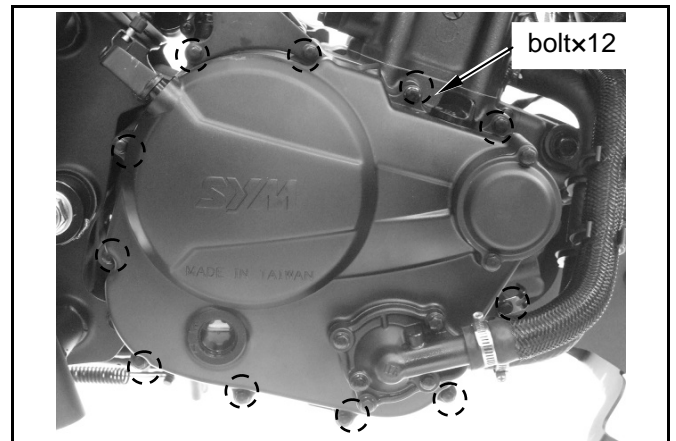

Remove clutch lifter(boltX6)。  
Remove clutch spring.

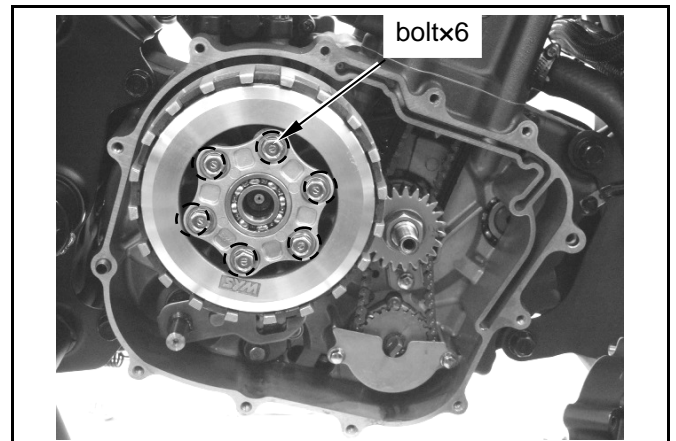

Remove clutch lock nut.  
Remove clutch center, friction disks, clutch plates, and pressing plate.

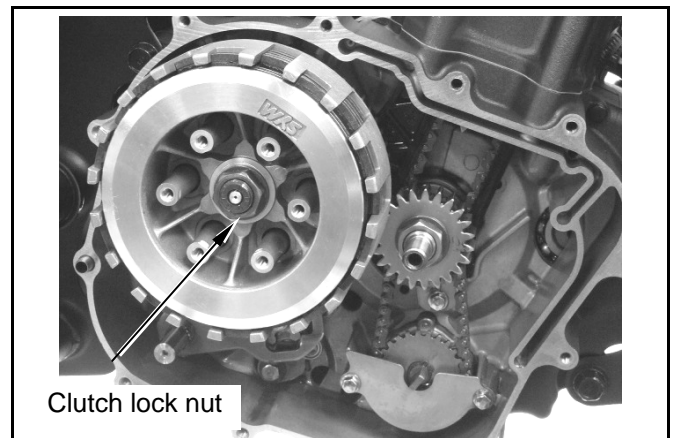

Remove washer, clutch outer, and center guide.

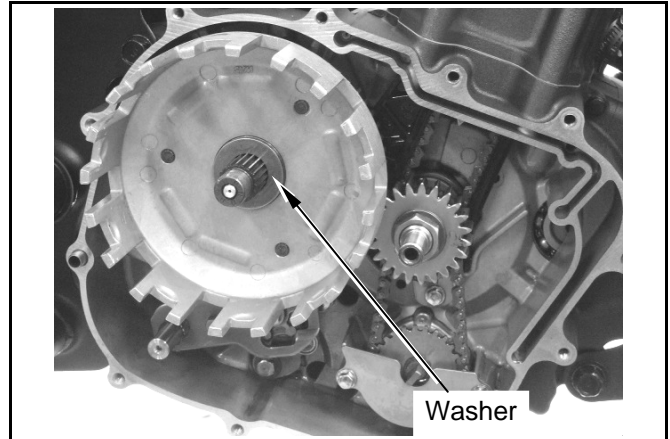

Disassemble the clutch center, clutch plates, clutch friction disks, and pressing plate.

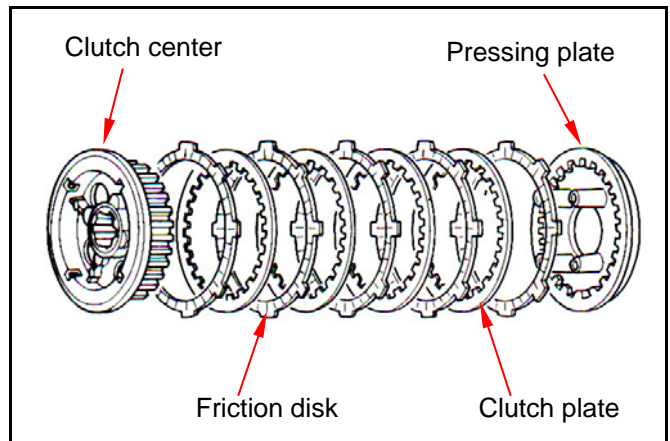

### Clutch inspection

#### Clutch spring inspection

Measure the free length of the 6 clutch springs.

**Service limit : 41.70mm**

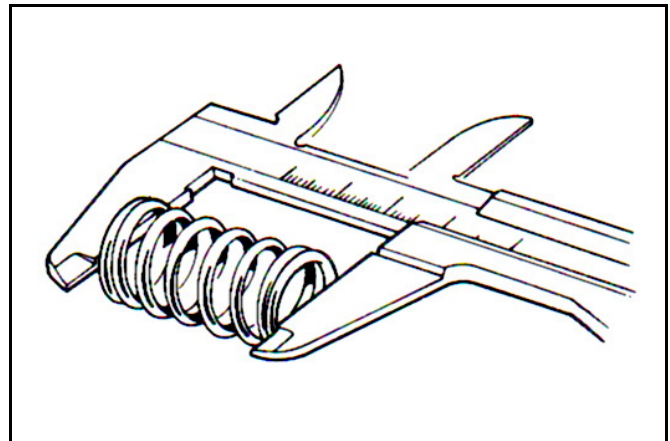

#### Clutch friction disk inspection

Measure the thickness of each clutch friction disk. If it's under service limit or damaged, please replace it with a new one.

**Service limit : 2.50mm**

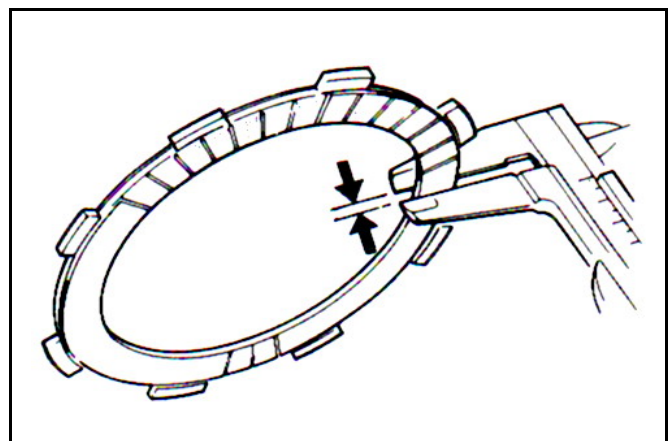

### Clutch plate inspection

Use a feeler gauge to measure the warp of each clutch plate.

Service limit : 0.2mm

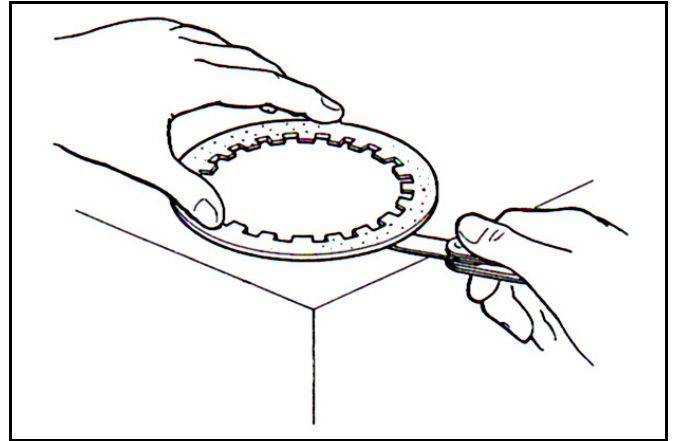

### Clutch outer inspection

Check if the clutch outer is cracked or damaged.



### Clutch installation

Install clutch washer, center guide.

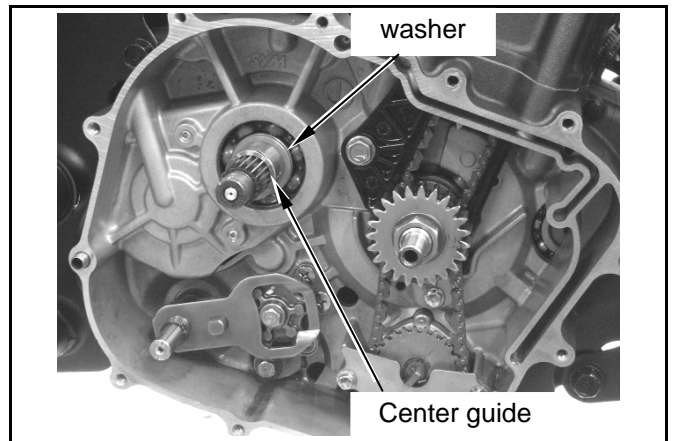

Install clutch outer and washer.

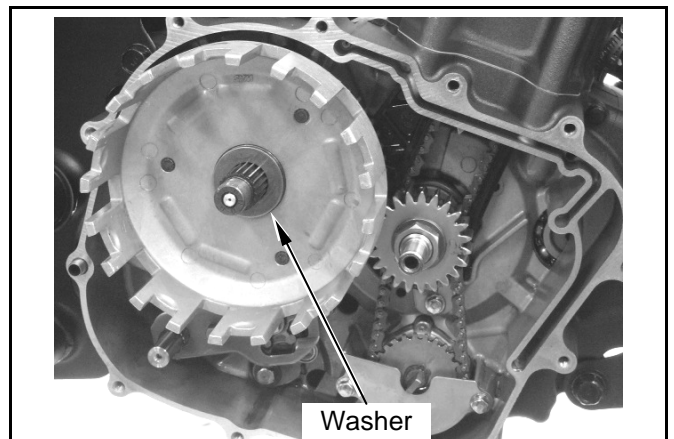

## 4. Lubrication System / Clutch / Transmission



Install clutch center, clutch plate, friction disk, and pressing plate.  
Tighten clutch lock nut.

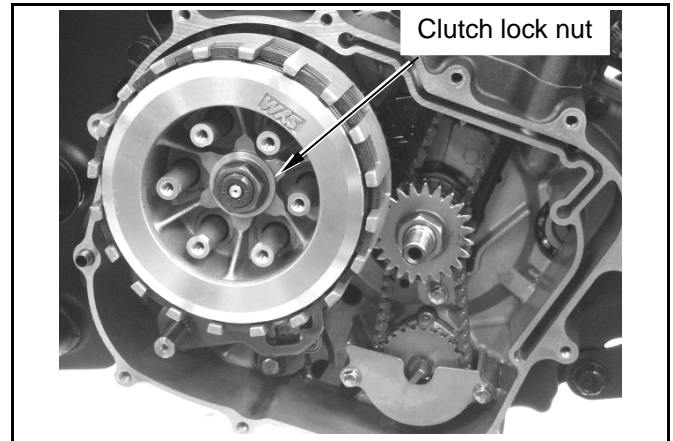

Install clutch spring, clutch lifter; tighten 6 bolts.  
Install right crankcase cover. (bolt×12).  
Install clutch cable.  
Fill in specified engine oil.

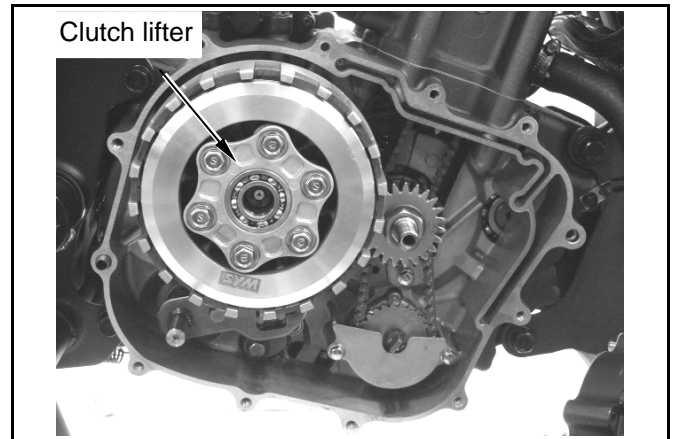

Turn the adjustment nut to optimize the clutch free play.  
**Free play : 10-20mm**

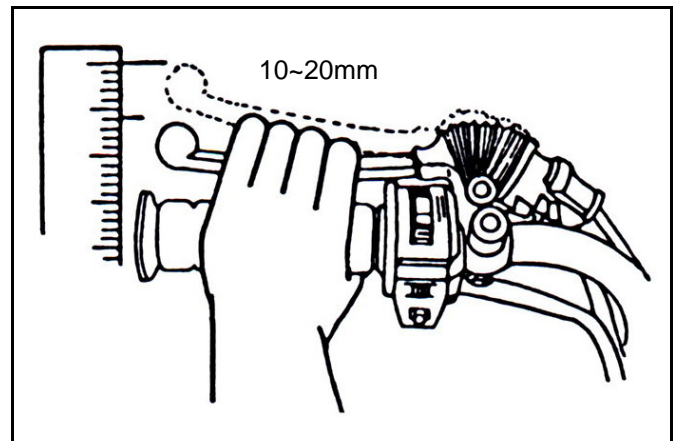

After achieving the correct free play, tighten the adjusting nut and the lock nut.

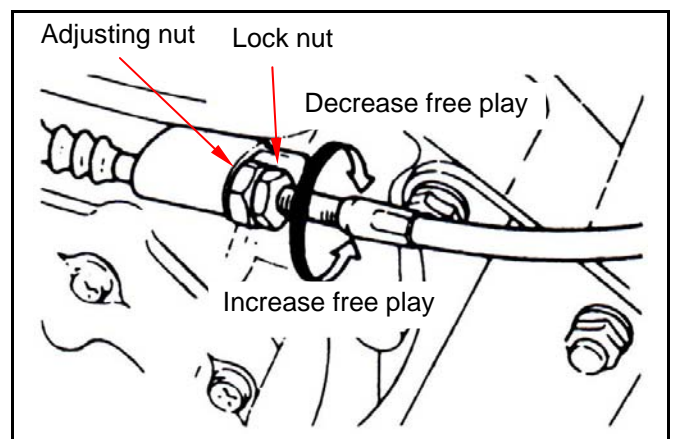

### Oil pump

- Drain all engine oil.
- Remove clutch cable.
- Remove right crankcase cover.
- Remove clutch assembly.
- Remove initial driven gear lock nut.
- Remove initial driven gear.

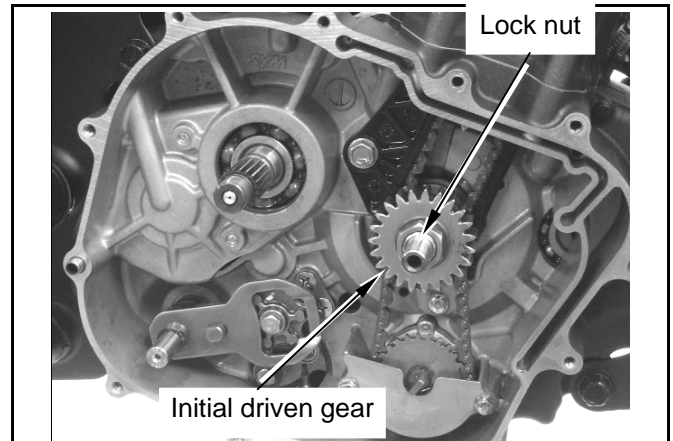

Remove oil pump cover. (boltX2)。

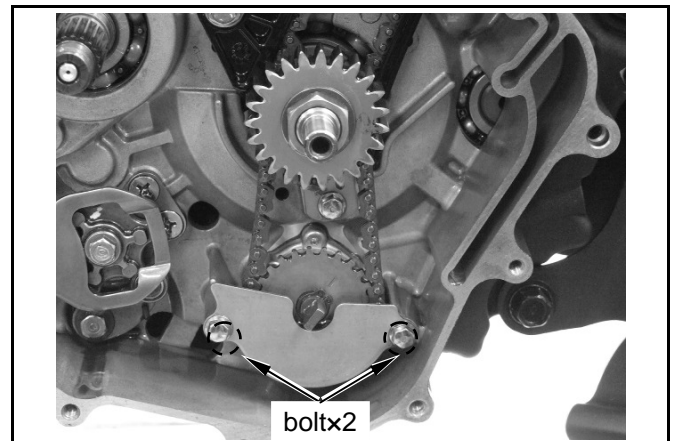

Remove oil pump drive gear fix circlip.  
Remove oil pump gear and chain.

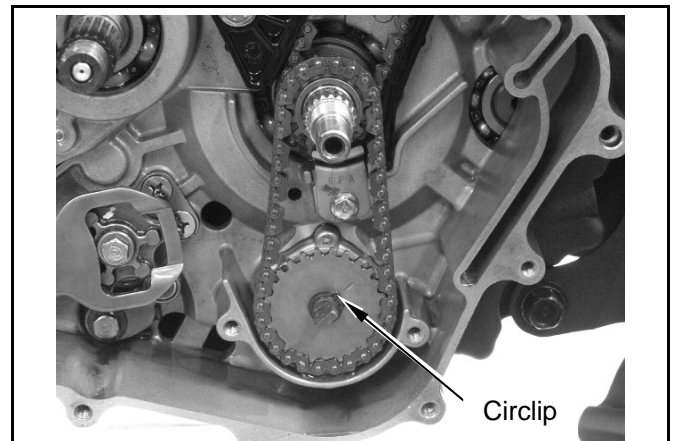

Remove oil pump. (holding screwX2) 。

### Caution

- It is recommended to remove the oil pump holding screw with impact screw driver.

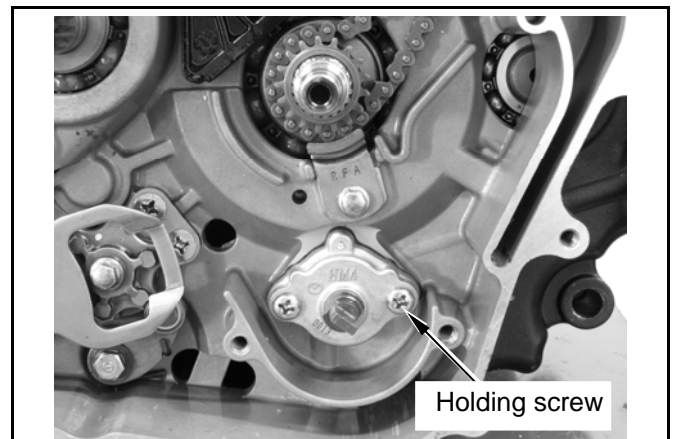

### Oil pump disassembly

Remove oil pump cover. (screwx1)  
Disassemble oil pump.



### Oil pump inspection

Check the clearance between oil pump body and outer rotor.

**Service limit: under 0.25 mm**

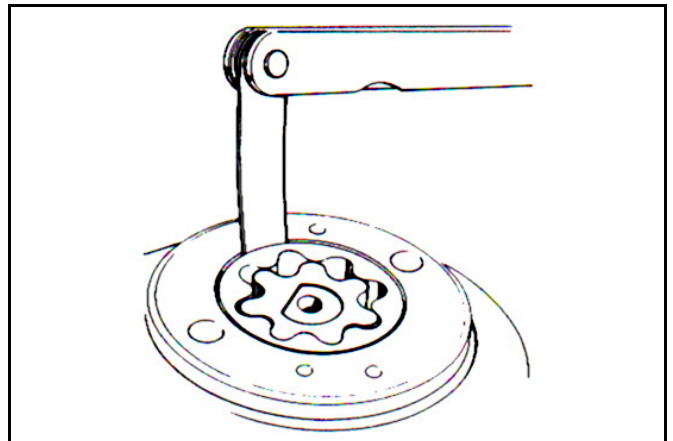

Check clearance between inner and outer rotors.

**Service limit: under 0.20mm**

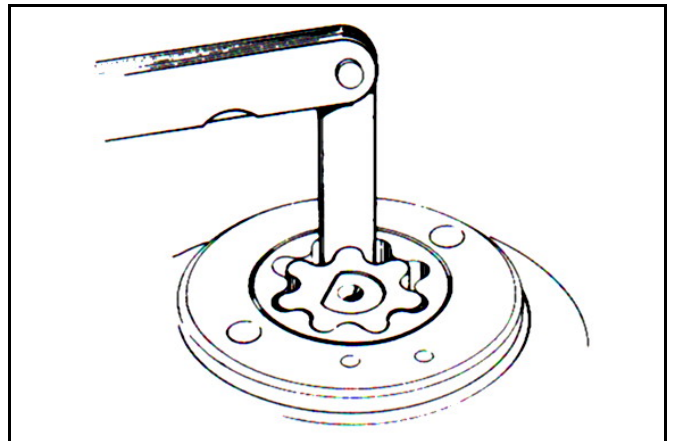

Check the unevenness between rotor face and pump body.

**Service limit: under 0.12 mm**

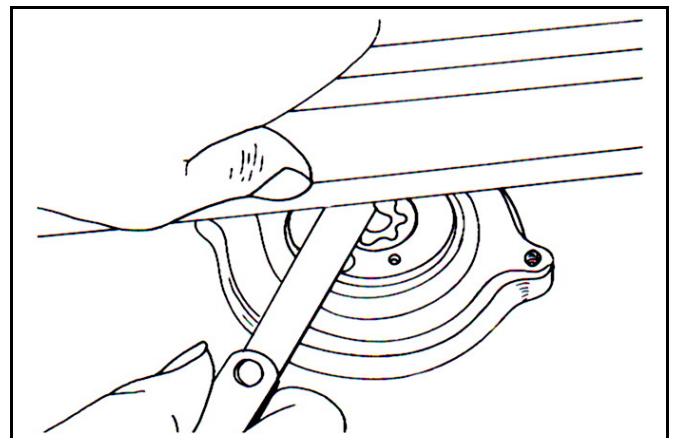

### Gear shift linkage mechanism

#### Gear shift linkage disassembly

Remove shifting lever. (boltx1)

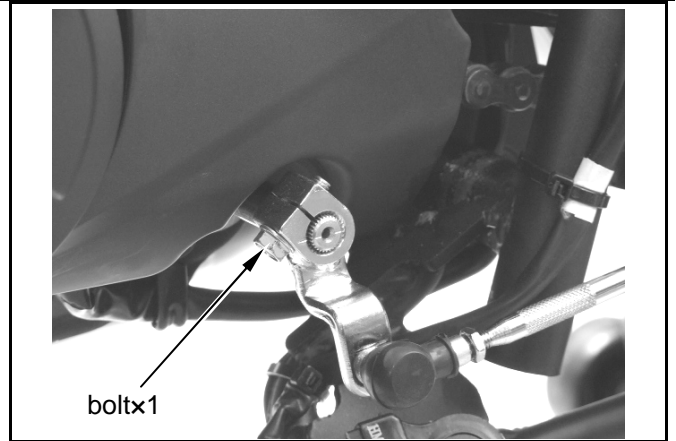

Remove clutch cable.  
Remove right crankcase cover.  
Remove clutch assembly.

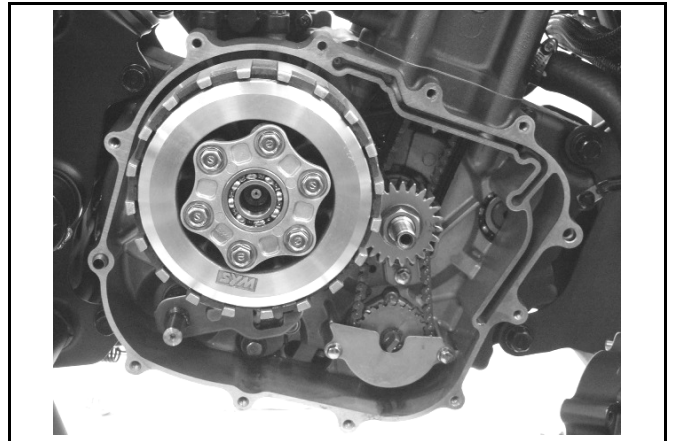

Take out the gear shifting spindle.



Remove the shifting drum stopper arm and the return spring. (boltx1)  
Remove shifting drum retainer. (boltx2)

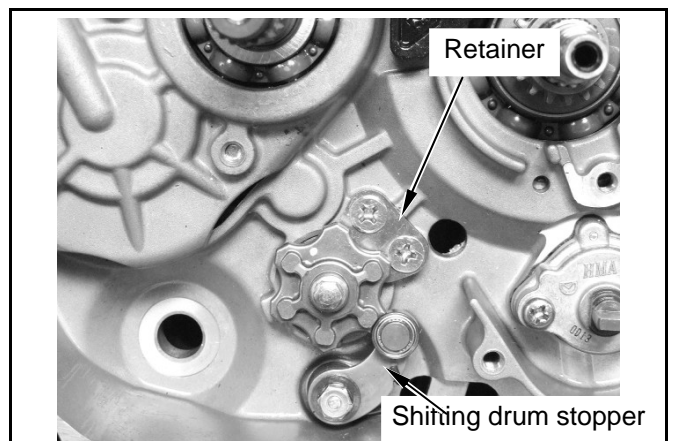

## 4. Lubrication System / Clutch / Transmission



Remove shifting cam. (bolt×1)  
Remove alignment pin.

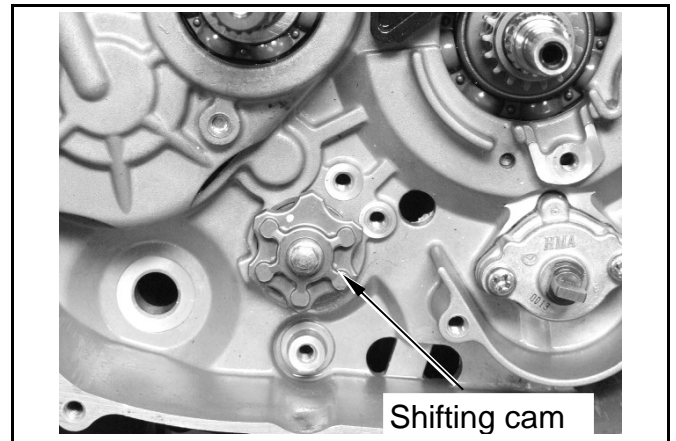

### Inspection

Check if shifting spindle and the fork assembly damaged or worn.

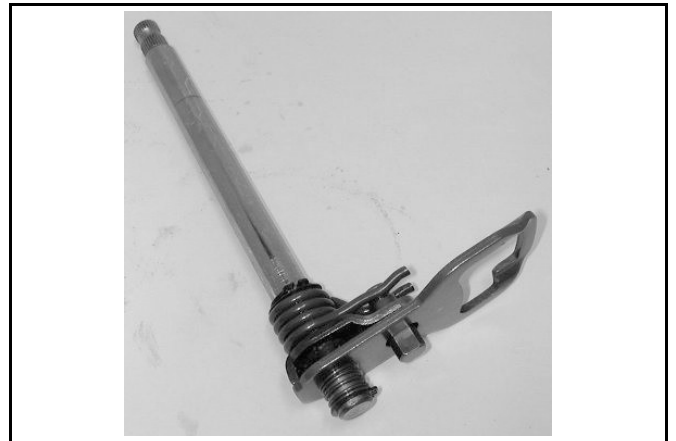

Check if shifting drum stopper arm and the return spring damaged or worn.



Check if gear shifting cam damaged or worn.





### Gear shift linkage mechanism installation

Install alignment pin.

Install the gear shifting cam by matching the alignment pin.

Tighten gear shifting cam lock bolt. (boltx1)。

**Torque value : 0.8~1.2kgf-m**

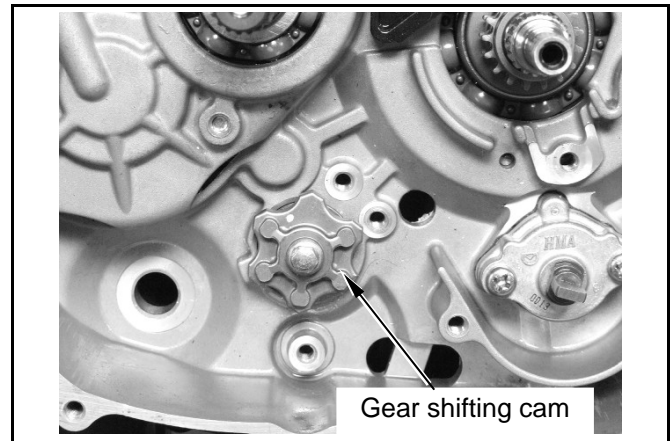

Install shifting drum stopper and the return spring. (bolt X 1)

Install shifting drum retainer. (boltx2)

**Torque value : 0.8~1.2kgf-m**

### Caution

- Check if the stopper is working smoothly after assembly.

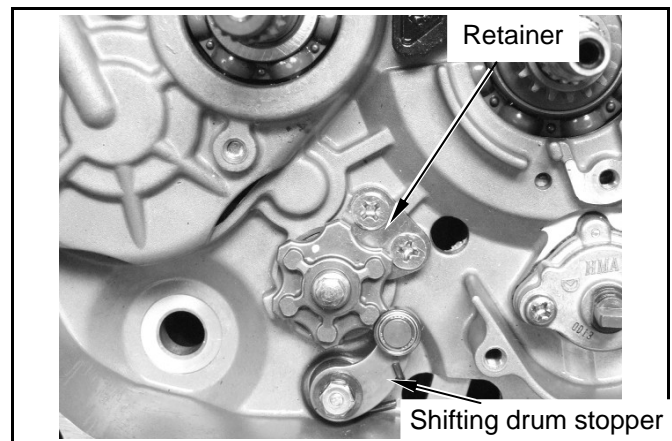

Install the gear shifting spindle and the fork assembly. Then install the shifting pedal (bolt X1)

### Caution

- The return spring on the shifting spindle should contact the salient on the crankcase.

Install clutch assembly.

Install alignment pin and another new right crankcase gasket, then the right crankcase cover.

Connect clutch cable, and adjust the clutch free play.

Fill in specified engine oil.

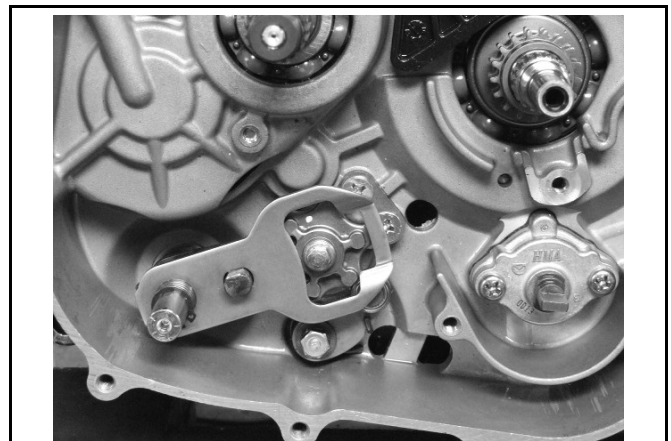

**NOTE:**

<b>Mechanism Diagram .....5-1</b>	<b>ACG Stator Disassembly .....5-3</b>
<b>Precautions in Operation .....5-2</b>	<b>ACG Flywheel/ Starter Clutch ....5-5</b>

**Mechanism diagram**

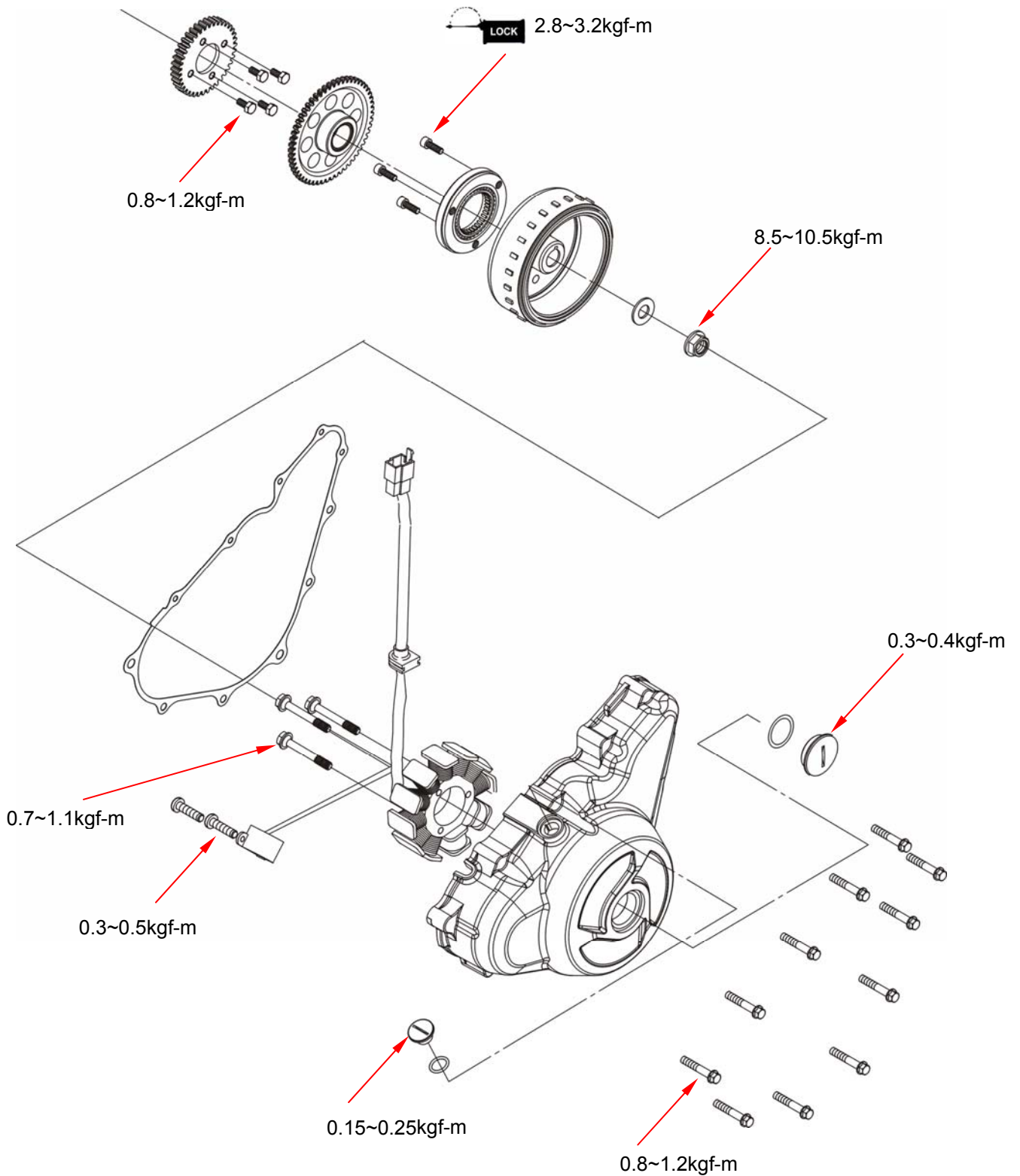

### Precautions in operation

#### General information

- For engine troubleshooting and inspection, please refer to the first chapter.
- Starting Motor repairing process and cautions please refer to Chapter 14<sup>th</sup>.

#### Specifications

measurement : mm

Item	Standard	Service limit
Start Driven Gear exterior diameter	42.192~42.208	42.100
Starting Clutch interior diameter	25.026~25.045	25.050

#### Torque value

Flywheel nut	8.5~10.5kgf-m
Left crankcase cover bolt	0.8~1.2kgf-m
Starting clutch inner-hexagon bolt	2.8~3.2kgf-m with screw adhesive

#### Special tool

Flywheel puller	SYM-3111000-HMA
-----------------	-----------------

### ACG stator disassembly

#### ACG stator disassembly

Remove ACG coupler and CPS coupler.

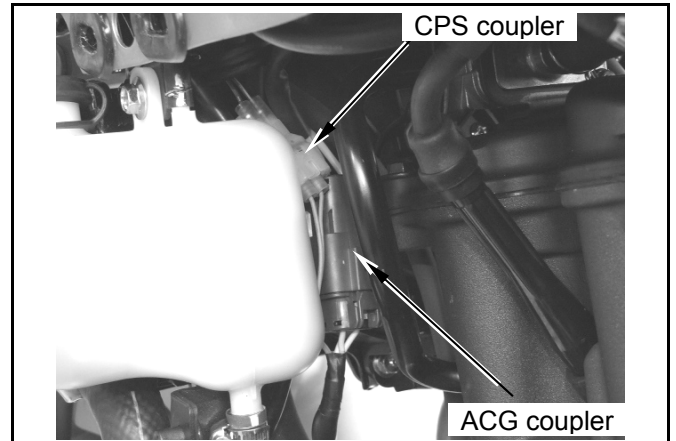

Remove left crankcase chain cover. (bolt×2)

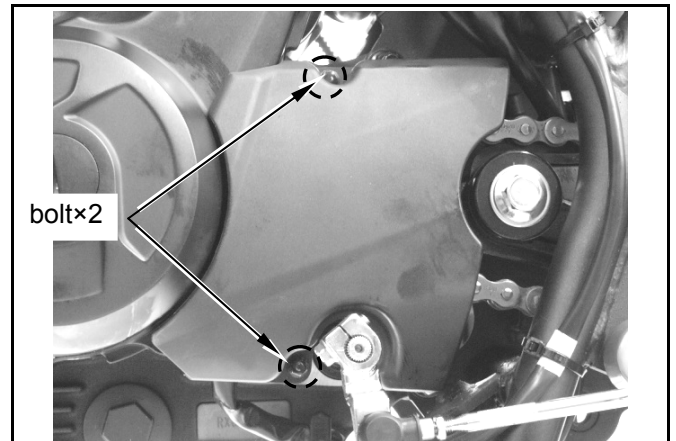

Remove left crankcase cover. (bolt×11)。

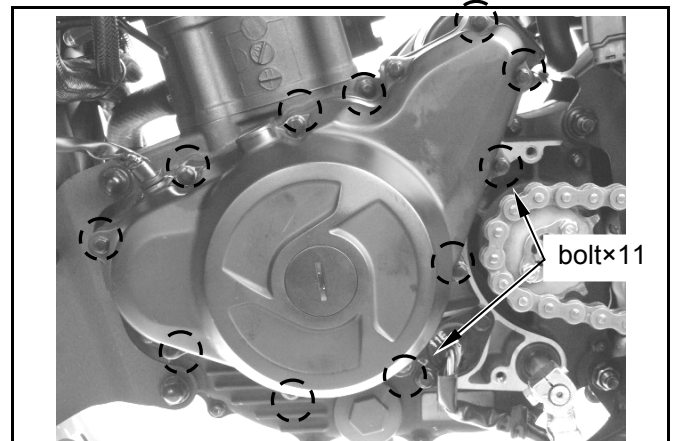

Remove foreign objects and gasket on the interface of crankcase and cover.

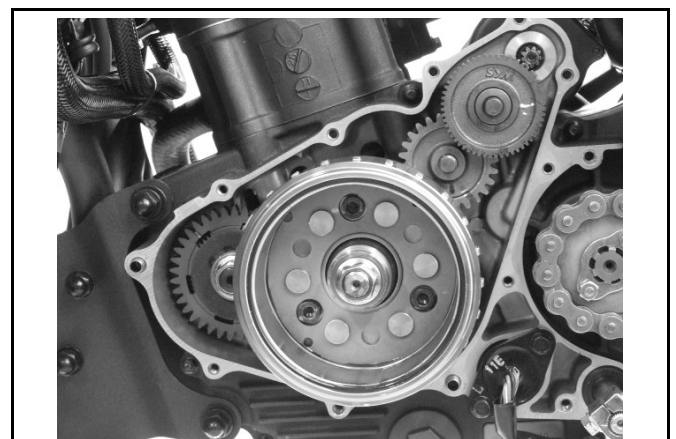

**Remove ACG stator holding screw.  
(screwX3)**

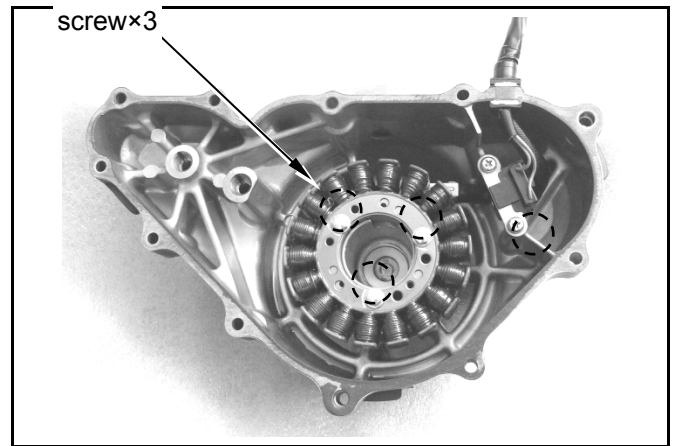

### ACG stator inspection

Remove ACG coupler and check its resistance and grounding condition with ohmmeter. Replace ACG if any abnormal situation found.

	V	$\Omega$
Y1	70~80	$0.42\Omega \pm 20\%$
Y2	70~80	$0.42\Omega \pm 20\%$
Y3	70~80	$0.42\Omega \pm 20\%$

Without removing coupler, voltage generated can be measured by voltage meter while the engine is running.

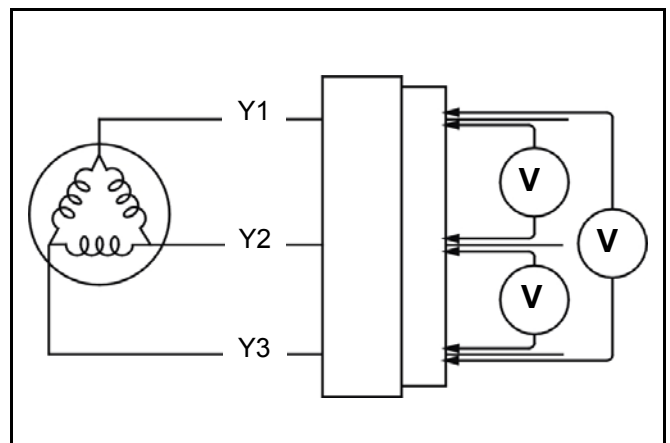
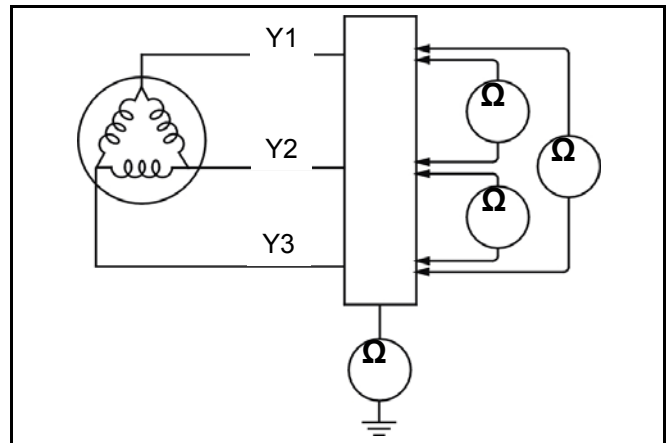

### ACG stator assembly

Install ACG stator. (screw×3)。

Assemble the stator wire correctly onto the L-crankcase cover with the rubber seal.

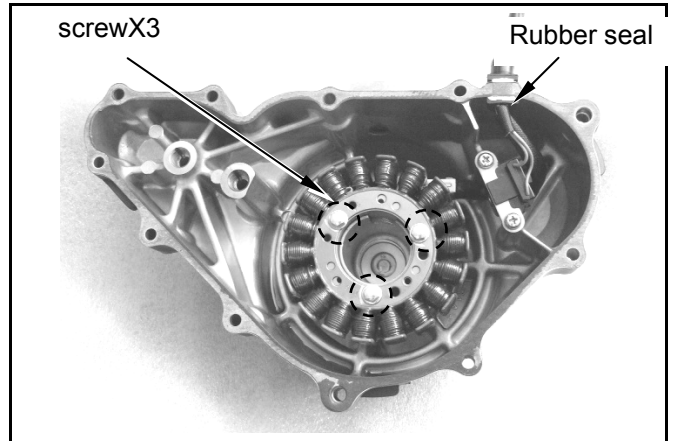

Install dowel pin and new L crankcase cover gasket.

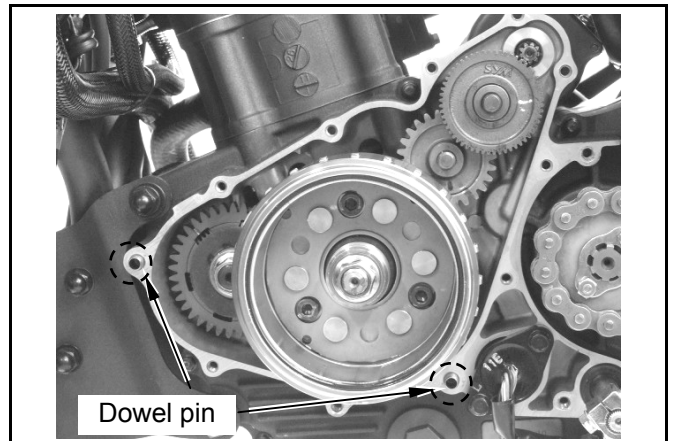

Install left crankcase cover. (bolt×11)。

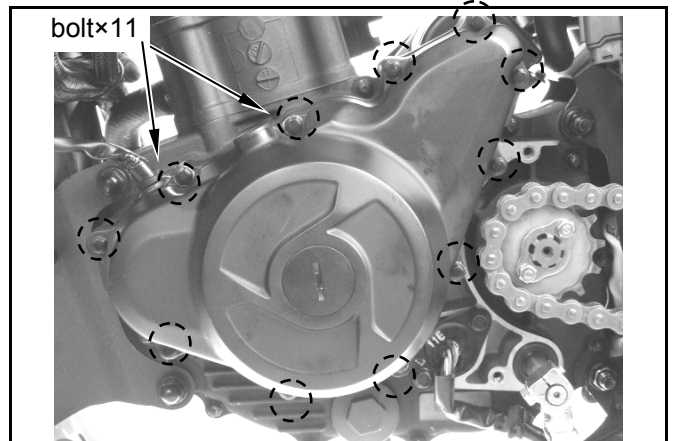

### ACG flywheel / starter clutch

#### ACG flywheel / starter clutch disassembly

Remove start reduction gear A / B and shaft.

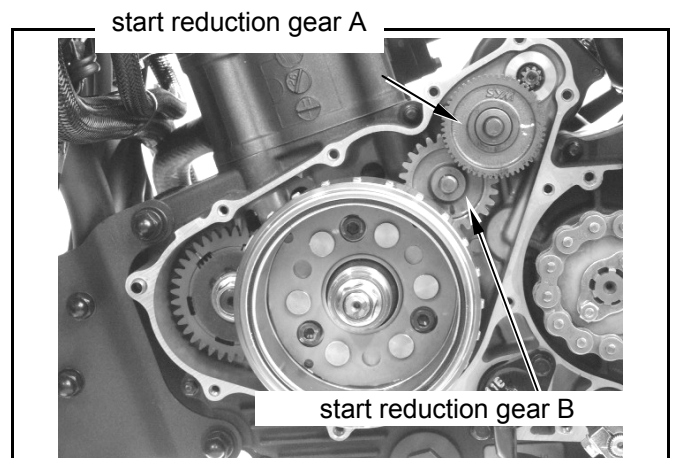

## 5. AC Generator / Starting Clutch



Remove flywheel, starting clutch, and start driven gear with flywheel puller and shaft protector.

**Special tool:**

**ACG flywheel puller SYM-3111000**

**Shaft protector**

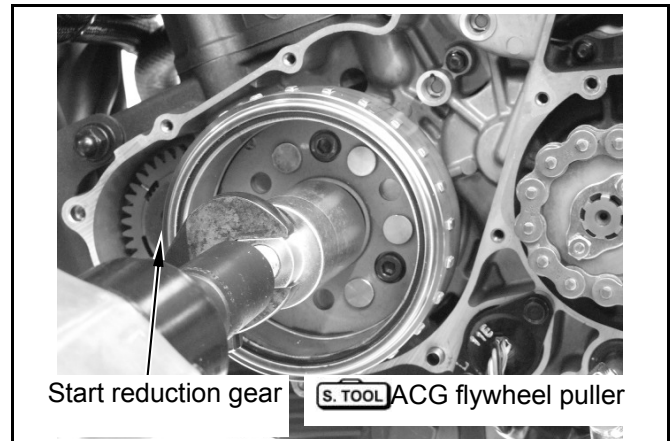

### Starting clutch inspection

Assemble the start driven gear onto the starting clutch.

Hold the starting clutch and turn the start driven gear.

Start driven gear should only be able to turn counterclockwise.

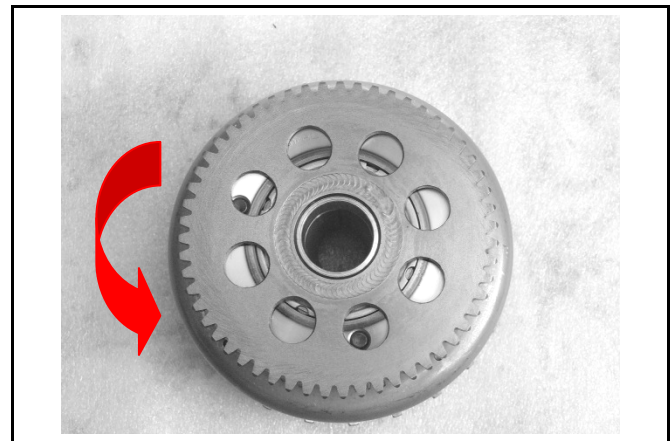

Check if the start driven gear damaged or worn.

Measure the exterior diameter of the start driven gear.

**Service limit:**

**Interior diameter: over 25.050 mm**

**Exterior diameter : over 42.100 mm**

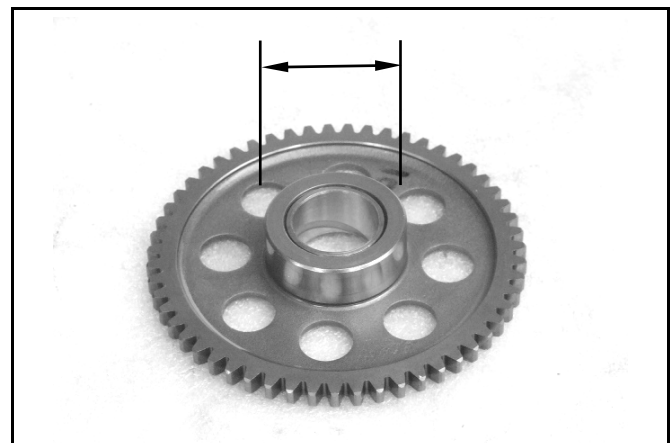

Check if the roller of starting clutch damaged or worn.





### ACG flywheel / starting clutch assembly

Install ACG flywheel, starting clutch, and starting gear.

Tighten ACG flywheel. (bolt×1)。

**Torque value: 8.5~10.5kgf-m**

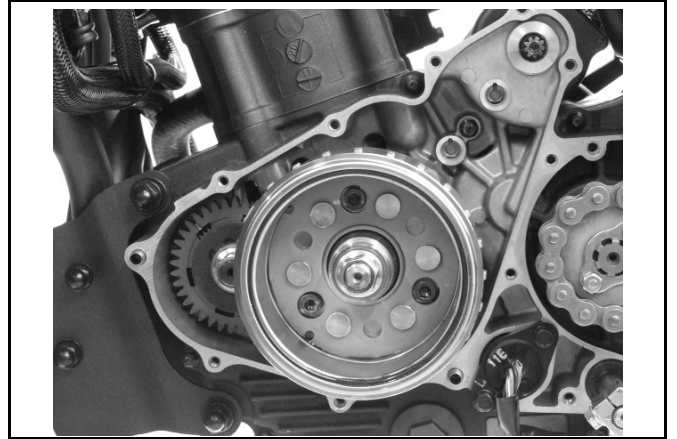

Install start reduction gear A / B and shafts..



Install dowel pin and new gasket.

Install left crankcase cover. (bolt×11)。

**Torque value : 0.8~1.2kgf-m**

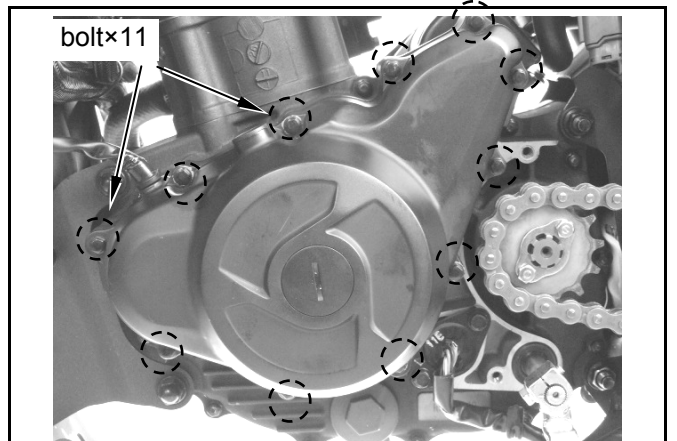

Install left crankcase chain cover. (bolt×2)

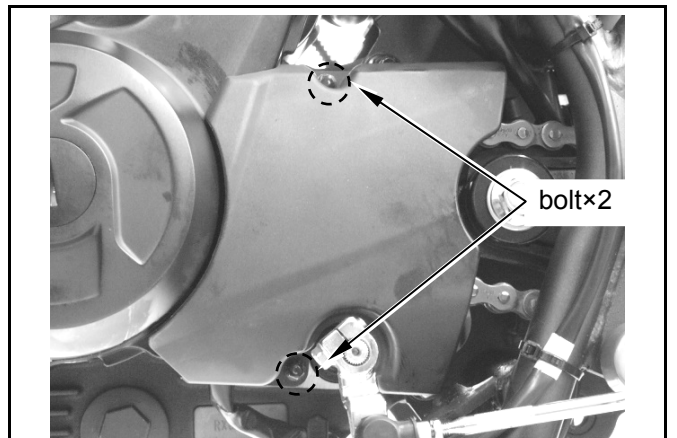

**NOTE:**

**Precautions in Operation .....6-1**

**Engine Removal .....6-2**

**Engine Installation .....6-7**

**6**

### Precautions in operation

#### General information

- During the maintenance of a removed engine, you need to use an adjustable rack or cart to support the engine.
- The following parts can be repaired with the engine installed on the frame:
  1. AC generator
  2. Starting cultch
  3. Clutch
  4. Transmission mechanism
- You must remove the engine for repairing the following parts:
  1. Piston
  2. Cylinder
  3. Cylinder head
  4. crank shaft / balancing shaft
  5. Transmission mechanism

#### Specification

Model		Specification
Engine oil capacity	Regular exchange	1500 c.c.
	Fully disassembly	1800 c.c.

#### Torque value

- Engine suspension nut (the upper part of engine and frame)    2.4~3.0kgf-m
- Engine assembly nut (the front part of engine and engine hanger)    3.0~4.0kgf-m
- Engine assembly nut (the back part of the engine and frame)    4.5~5.5kgf-m
- L crankcase chain cover bolt                    0.8~1.2kgf-m
- Driven sprocket bolt                            0.8~1.2kgf-m

## 6. Engine Removal



### Engine removal

Drain all engine oil.

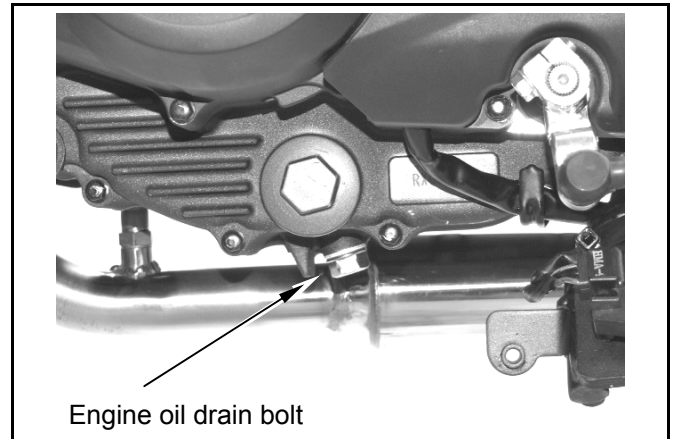

Drain all coolant.

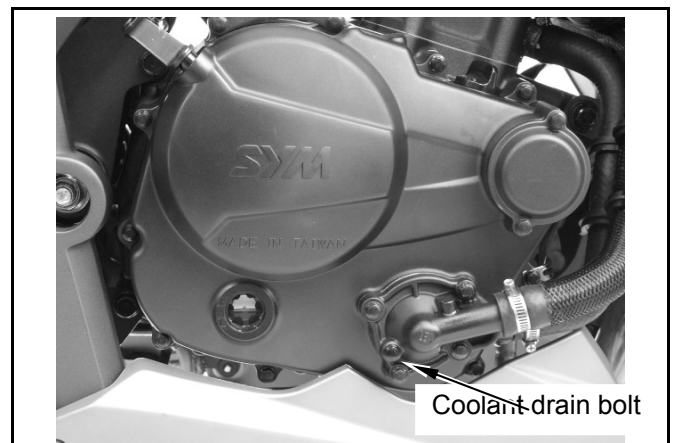

Disconnect CPS and ACG couplers.

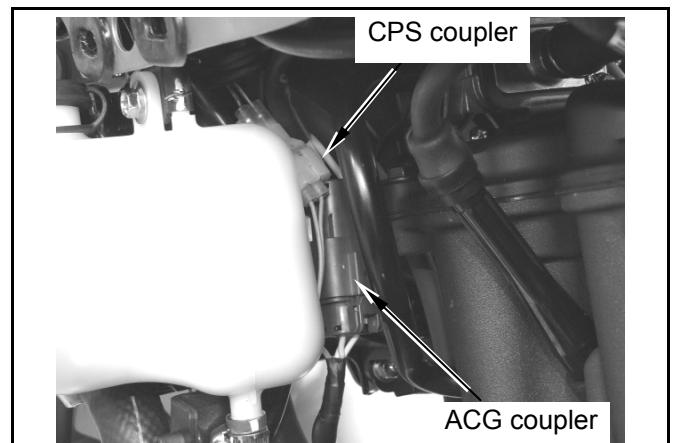

Disconnect starter motor coupler.

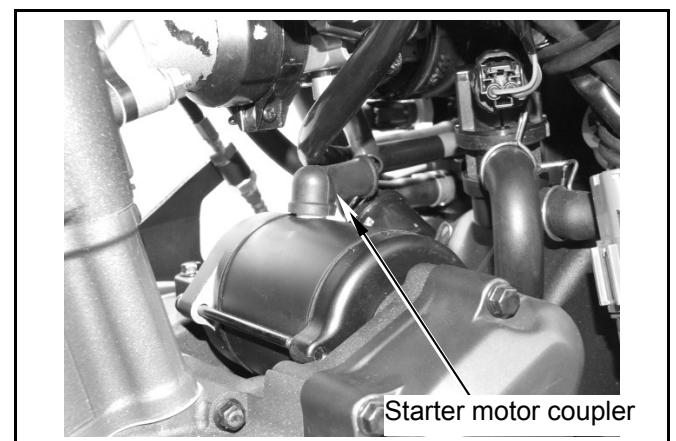

Loosen clutch cable lock nut and adjusting nut, remove clutch cable.

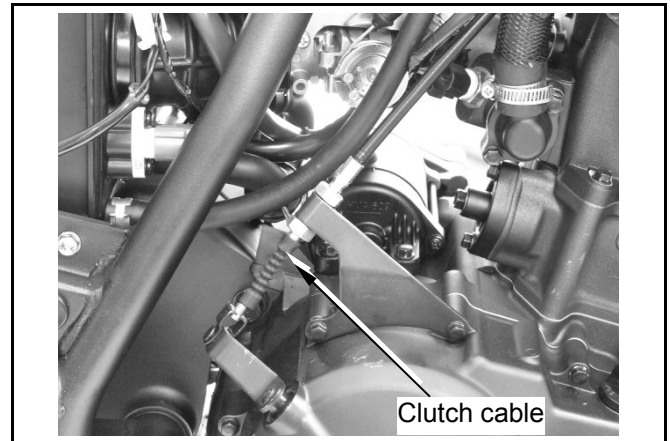

Loosen throttle wire lock nut, remove throttle cable.  
Disconnect MAP sensor and ISC couplers.

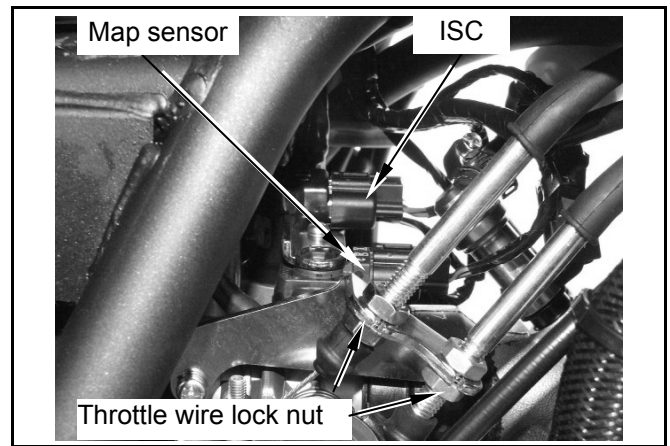

Loosen coolant hose band, remove coolant hose.

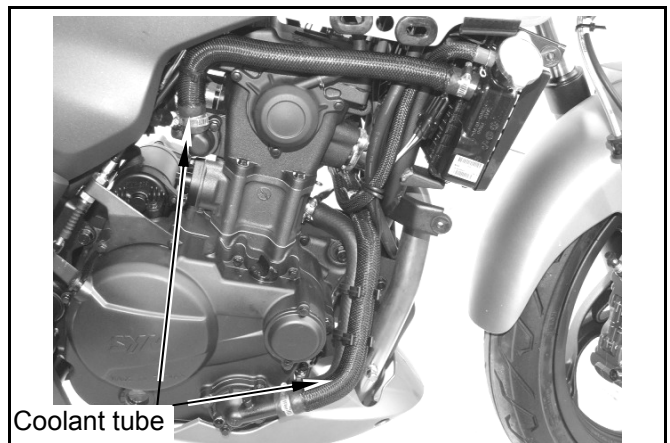

Remove PCV tube.  
Disconnect TW sensor coupler.

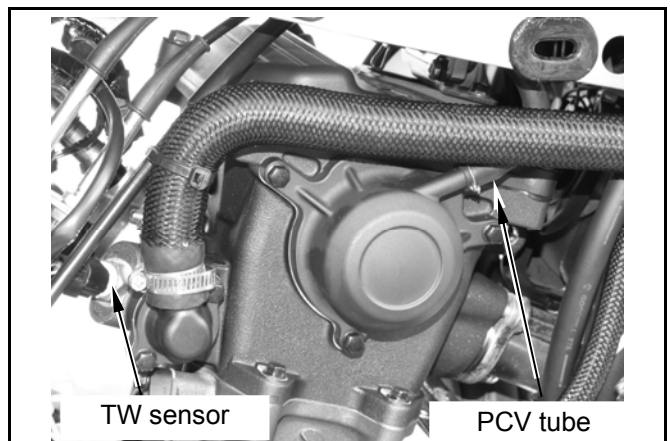

## 6. Engine Removal



Disconnect ignition coil coupler and AISV tube.

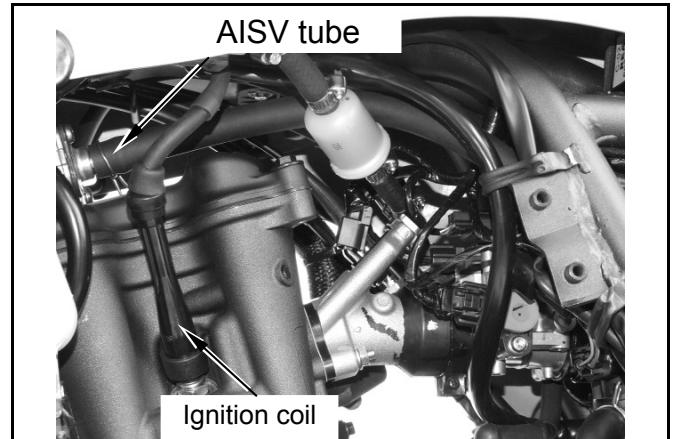

Disconnect fuel hose.  
Disconnect injector and TPS couplers.  
Remove injector. (lock nutX2)

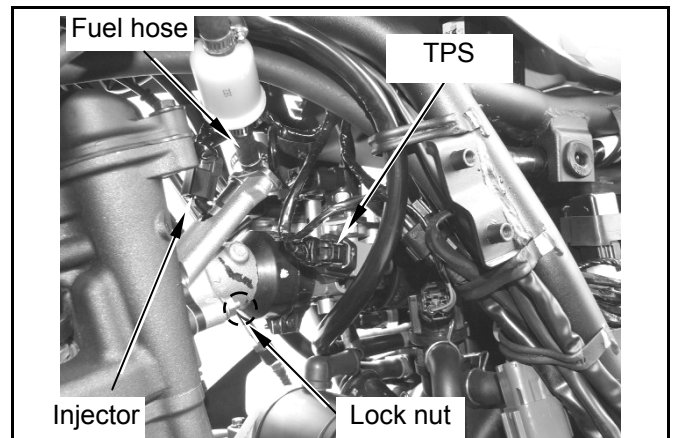

Loosen rear wheel axle lock nut.  
Loosen drive chain adjusting nut and push the rear wheel forward.

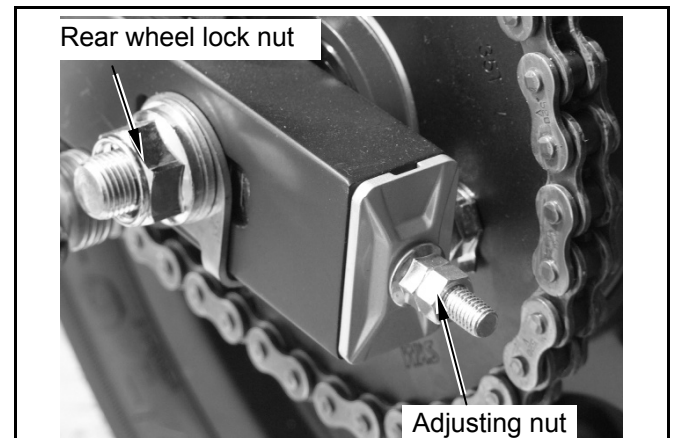

Remove left crankcase chain cover.  
Remove the drive sprocket bolts (bolt×2), sprocket fixing plate, drive sprocket, and chain.

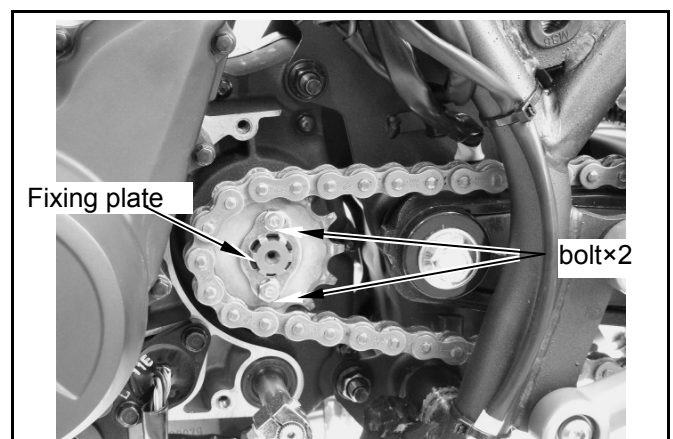

Disconnect O2 sensor coupler.

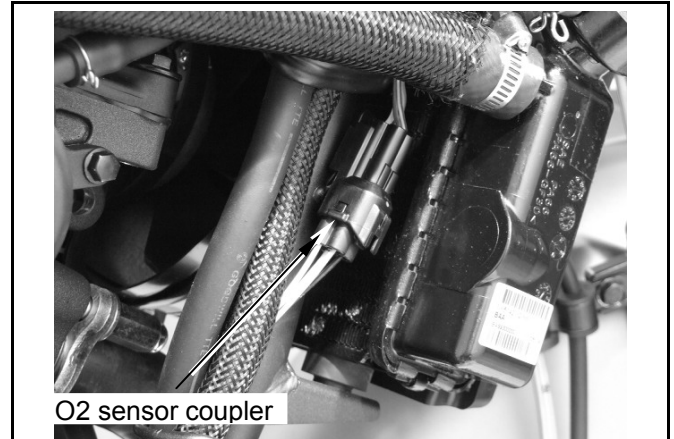

Remove exhaust pipe front lock nut. (nut×2).

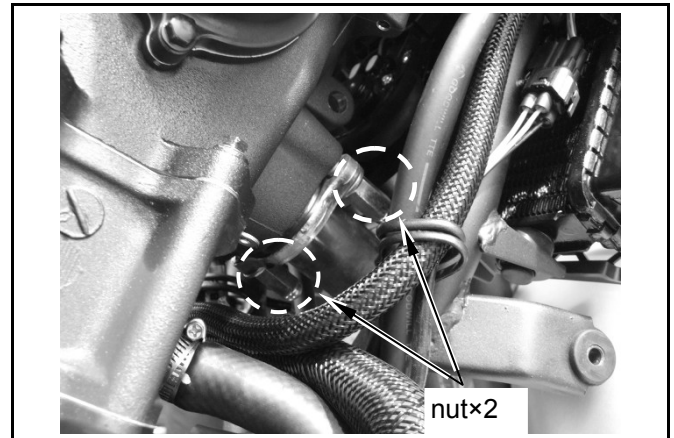

Remove the exhaust pipe center bolt.

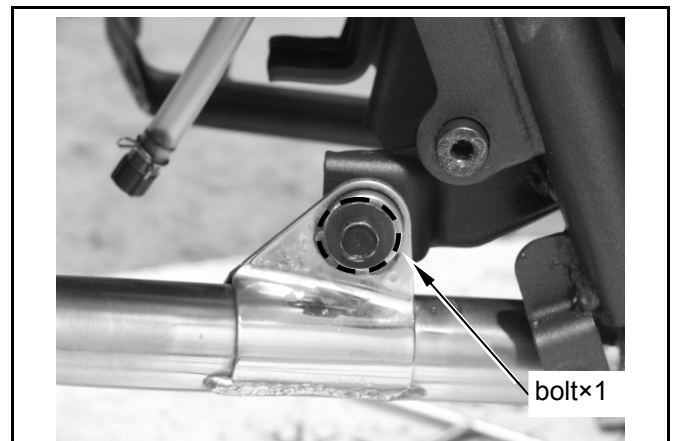

Remove the exhaust pipe rear bolt.  
Remove the exhaust pipe.

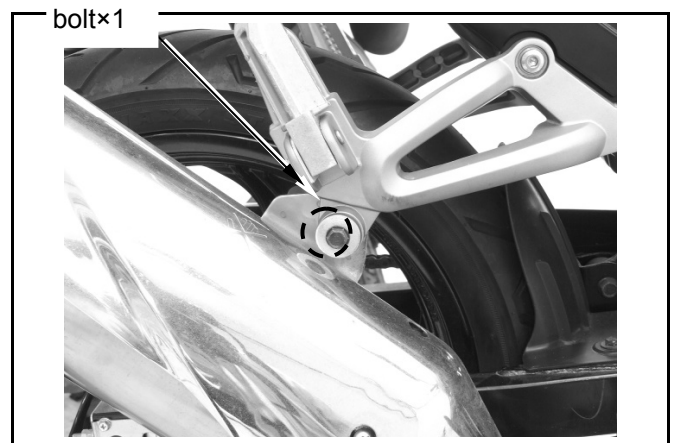

## 6. Engine Removal



Settle the engine on a rack.  
Remove engine front hanger. (nut×4, bolt×4)

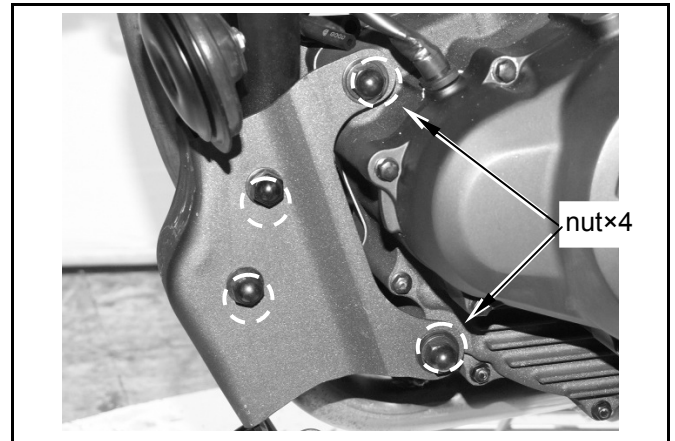

Remove engine rear holding bolts. (nut×2,  
bolt×2).  
Remove the engine.

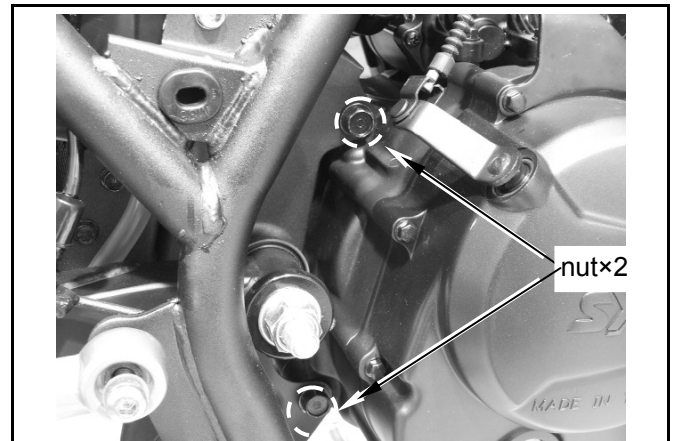



### Engine installation

Install the engine in the reverse order of removal.

#### Caution

- When assembling, always pay attention to possible injuries.
- Wires, cables, tubes, and hoses cannot be bent or pressed.
- Please align the wires and cables in accordance with the setting diagram.

#### Torque value:

Engine suspension nut (the upper part of engine and frame)                    **2.4~3.0kgf-m**

Engine assembly nut (the front part of engine and engine hanger)            **3.0~4.0kgf-m**

Engine assembly nut (the back part of the engine and frame)                **4.5~5.5kgf-m**

L crankcase chain cover bolt        **0.8~1.2kgf-m**

Driven sprocket bolt                 **0.8~1.2kgf-m**

After installation, fill in specified engine oil and coolant, adjust clutch lever free play, drive chain free slack, and idle speed.

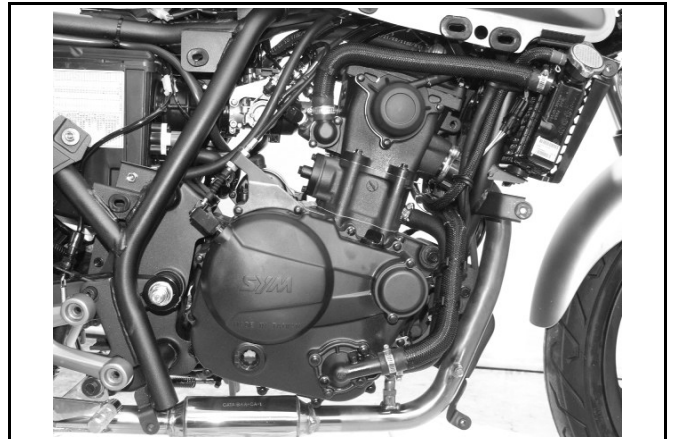

**NOTE:**

Mechanism Diagram .....7-1	Valve Guide Replacement .....7-10
Precautions in Operation .....7-2	Valve Seat Inspection & Refacing .....7-11
Troubleshooting.....7-3	Cylinder Head Assembly .....7-13
Cylinder Head Removal .....7-4	Cylinder Head Installation .....7-14
Cylinder Head Disassembly .....7-6	Valve Clearance Adjustment.....7-16
Cylinder Head Inspection .....7-8	

## Mechanism diagram

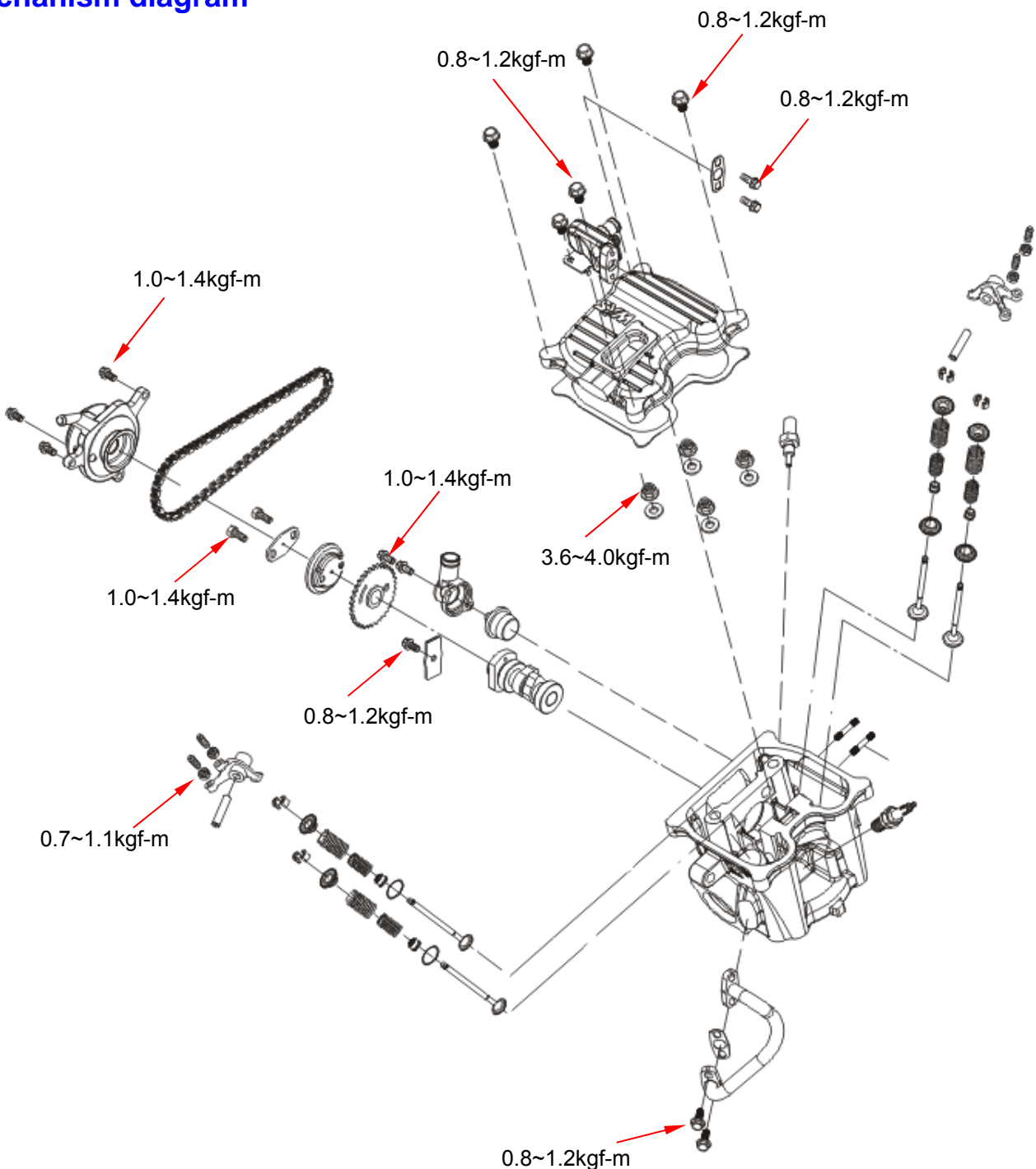

### Precautions in operation

#### General information

This chapter includes the repair information of cylinder head, valve, camshaft, and rocker arm. The engine must be removed before the repairing of cylinder head.

#### Specification

measurement: mm

Item		Standard	Service Limit	
Valve Clearance (when engine is cold)	In	0.10 ± 0.02	—	
	Ex	0.15 ± 0.02	—	
Compression Pressure		12 ± 2 kg/cm <sup>2</sup>	—	
Camshaft	Cam Lift			
	In	34.880	34.860	
	Ex	34.740	34.725	
Rocker Arm	Inner Diameter	11.982~12.000	12.080	
	Outer Diameter	11.966~11.984	11.936	
Valve	Valve stem outer diameter	In	4.975~4.990	4.900
		Ex	4.950~4.975	4.900
	Valve guide		5.000~5.012	5.030
	Clearance between Valve stem and guide	In	0.010~0.037	0.080
		Ex	0.025~0.062	0.100
	Valve spring free length	Inner spring	38.700	35.200
		Outer spring	40.400	36.900
	Valve seat width		1.600	—
Warpage/clearance between cylinder head and cylinder		—	0.050	

#### Torque value

Cylinder head bolt	0.8~1.2kgf-m	Rocker arm shaft setting plate bolt	0.8~1.2kgf-m
Cylinder head right bolt	1.0~1.4kgf-m	Valve adjusting holding nut	0.7~1.1kgf-m (Apply engine oil on threads and seats)
Cylinder head side cover bolt	1.0~1.4kgf-m	Spark plug	1.0~1.2kgf-m
Cylinder head nut	3.6~4.0kgf-m		
Cam chain sprocket bolt	1.0~1.4kgf-m		

#### Special tools

Valve Guide reamer 5.0mm	Valve Spring Assemble/Disassemble Tool
Valve Guide driver 5.0mm	SYM-1471110/20
Rocker arm shaft/ Camshaft Disassemble tool	Valve Clearance Adjustment Wrench
SYM-1445100	SYM-9001200
Valve Spring Compressor	SYM-1471100

### Troubleshooting

Engine performance will be affected by troubles on cylinder-head perimeter parts. The trouble usually can be determined by performing cylinder compression test or judging the abnormal noise.

#### Poor idling

The compression pressure is too low.

#### Low compression pressure

##### 1. Valve

- Improper valve clearance adjustment
- Burnt or bent valve
- Improper valve timing
- Valve spring damaged
- Valve carbon deposit
- Valve seat warpage
- Improper spark plug installation

##### 2. Cylinder head

- Cylinder head gasket leaking or damaged
- Tilted or cracked cylinder

##### 3. Piston

- Piston rings worn

#### High compression pressure

Too much carbon deposit on combustion chamber or piston head

#### Abnormal noise

- Improper valve clearance adjustment
- Burnt valve or damaged valve spring
- Camshaft worn out or damaged
- Chain worn out or loosened
- Auto-tensioner worn out or damaged
- Camshaft sprocket worn not or damaged
- Rocker arm or rocker arm shaft worn out

#### Smoke from exhaust pipe

- Valve guide or stem worn
- Valve guide oil seal worn

## 7. Cylinder Head / Valve



### Cylinder head removal

Remove engine. (Refer to chapter 6)

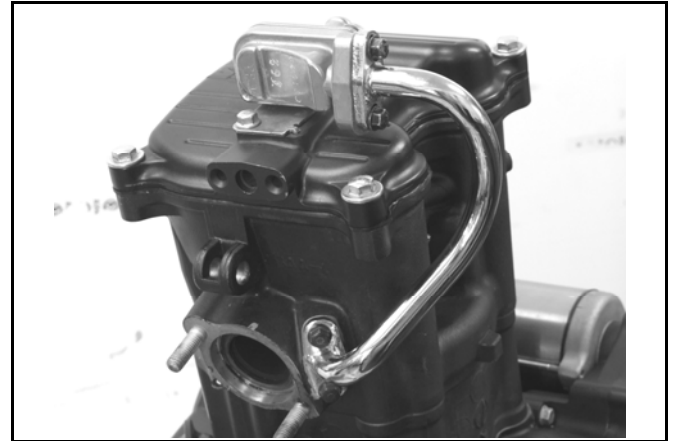

Remove auto-tensioner adjusting bolt.

Remove auto-tensioner. (bolt×2).

Remove thermostat. (bolt×2).

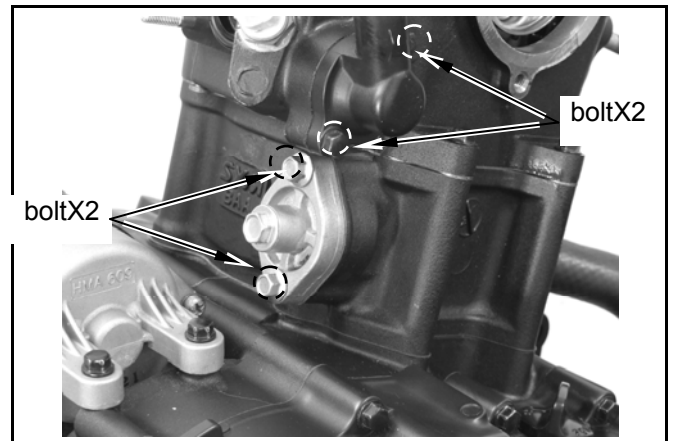

Remove AI pipe. (bolt×4).

Remove spark plug.

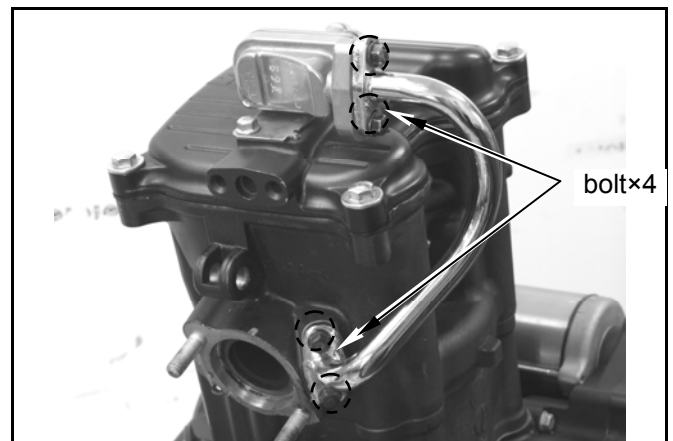

Remove cylinder head cover. (bolt×4).

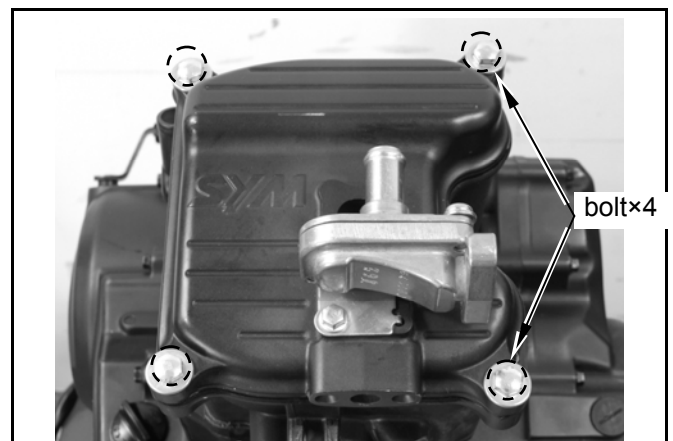

Remove cylinder head side cover. (bolt×3)。

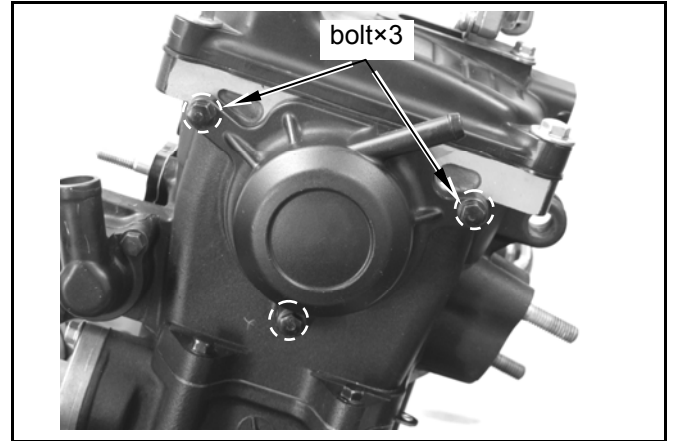

Remove timing-inspecting hole cap.  
Remove ACG cap, turn ACG flywheel counterclockwise, align "T" mark with the mark on L crankcase; align the timing marks on cam gear and cylinder head.

Remove cam gear lock nut. (bolt×2)。  
Remove cam gear.

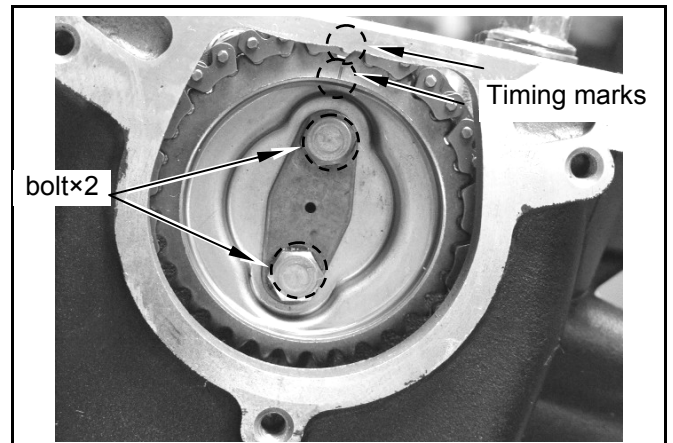

Remove bolts on right side of cylinder head first (bolt×2) , then the cylinder head nuts. (nut×4)  
Remove cylinder head.

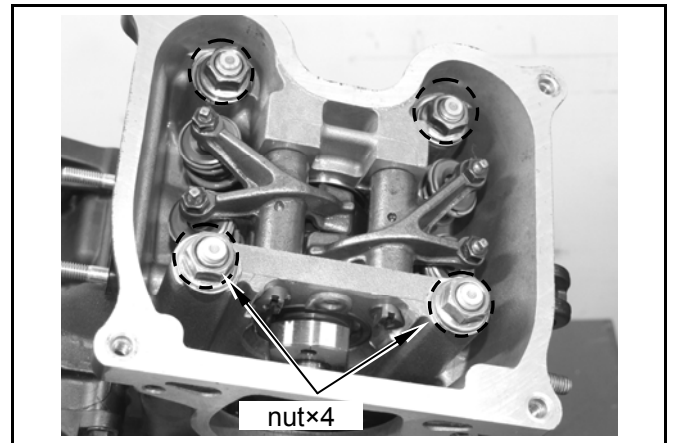

Remove cylinder head gasket and dowel pins.  
Remove cam chain guide.  
Clean up the matching surfaces between cylinder and cylinder head.

### Caution

- Do not damage the matching surfaces of cylinder and cylinder head
- Avoid residues of gasket or foreign materials falling into crankcase when cleaning.

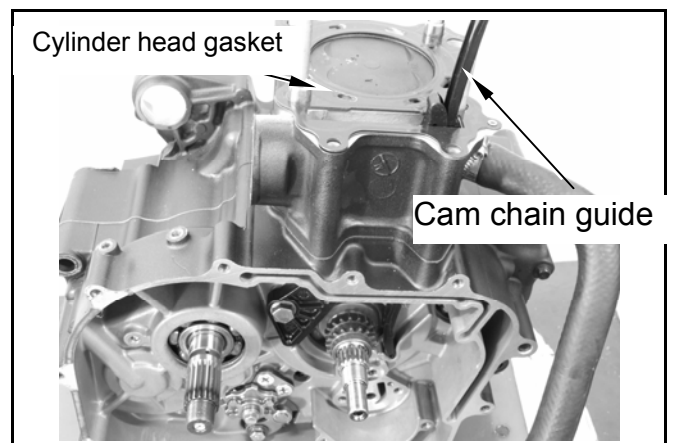

## 7. Cylinder Head / Valve



### Cylinder head disassembly

Remove rocker arm shaft holding plate.  
(bolt×1)

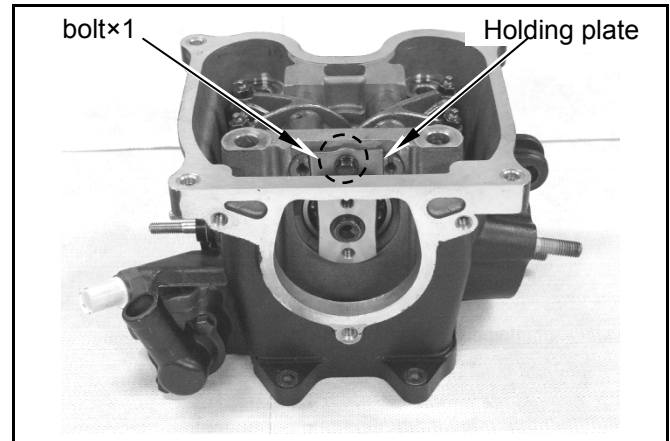

Use **Rocker arm / camshaft puller** to pull out the rocker arm shafts.

**Special tool:**  
**Rocker arm / camshaft puller SYM-1445100**

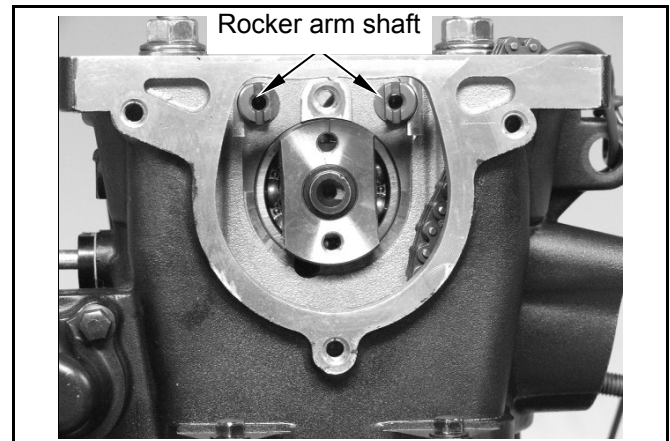

Use **Rocker arm / camshaft puller** to pull out the camshaft.

**Special tool:**  
**Rocker arm / camshaft puller SYM-1445100**

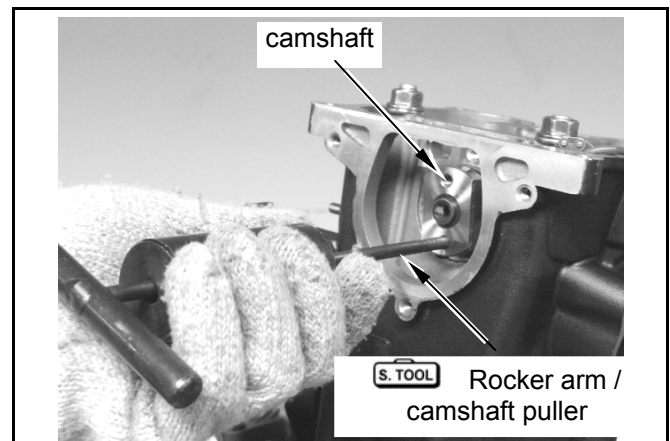

Use **Valve removal / assembly tool** to compress the spring, remove the valve cotter.

**Special tool:**  
**Valve removal / assembly tool**  
**SYM-1471110-SY125**

### ⚠ Caution

- Do not over compress the valve spring.
- When removing springs, place cloth in combustion chamber to hold the valves avoiding bending the valve.

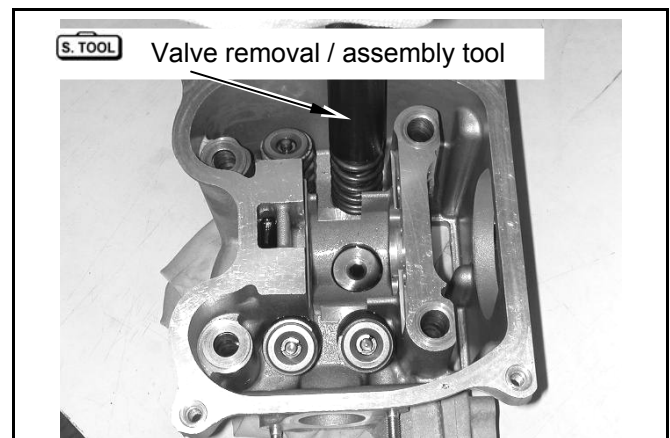



Remove cotters, springs, and the spring retainers.

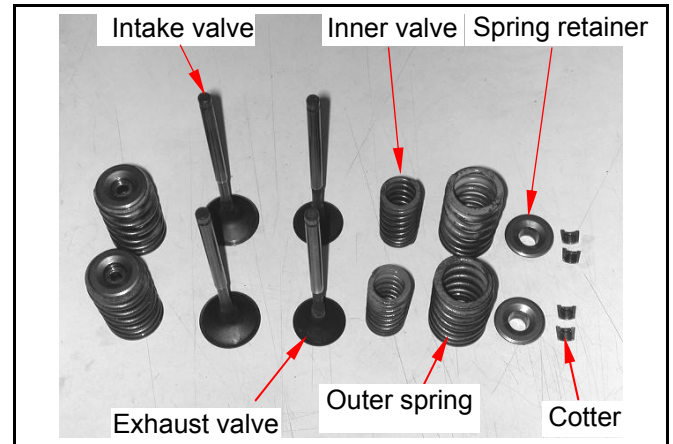

Remove valve guide oil seals.

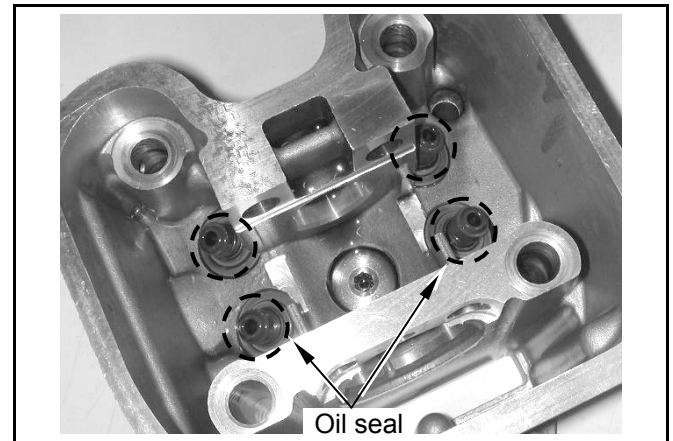

Clean up carbon deposit in combustion chamber.  
Clean up cylinder head matching surface.

**⚠ Caution**

- Do not damage cylinder head matching surface.

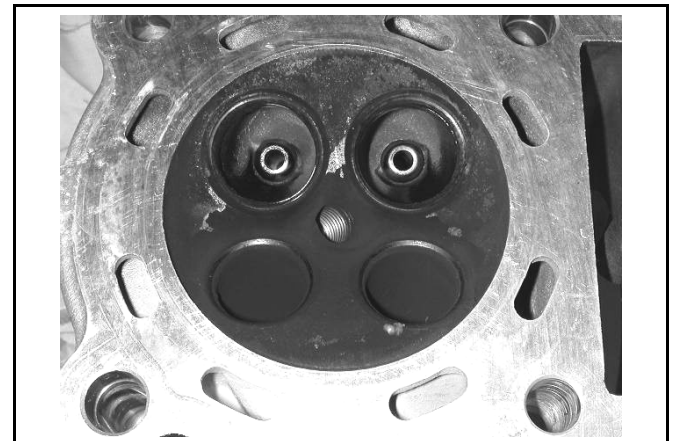

### Cylinder head inspection

#### Cylinder head surface / hole

Check if spark plug hole and valve hole cracked or damaged.

Measure the cylinder head surface for warpage.

**Service limit: 0.05mm**

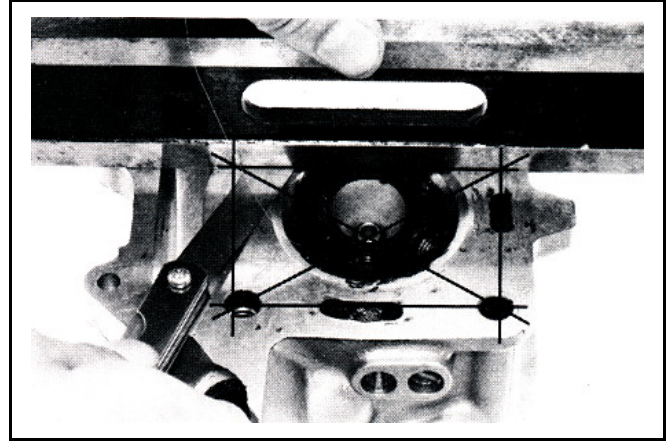

#### Camshaft

Measure the camshaft.

**Service limit:**

**Intake: 34.860mm**

**Exhaust: 34.725mm**

Check if the camshaft bearing loosened or worn, replace the camshaft assembly if necessary.

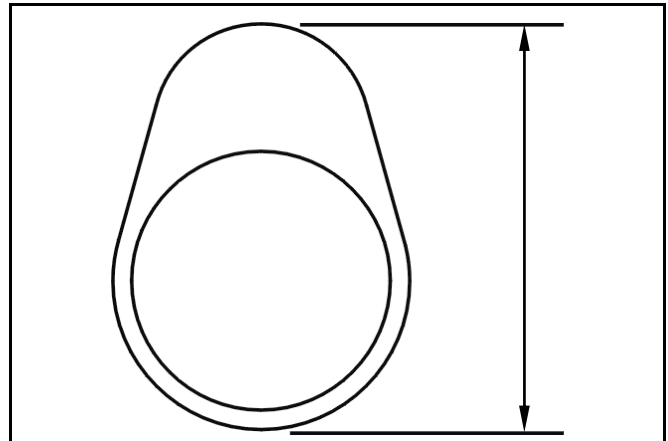

#### Rocker arm

Measure rocker arm inner diameter.

**Service limit: 12.080 mm**

Check if the oil hole clogged and the surface worn.

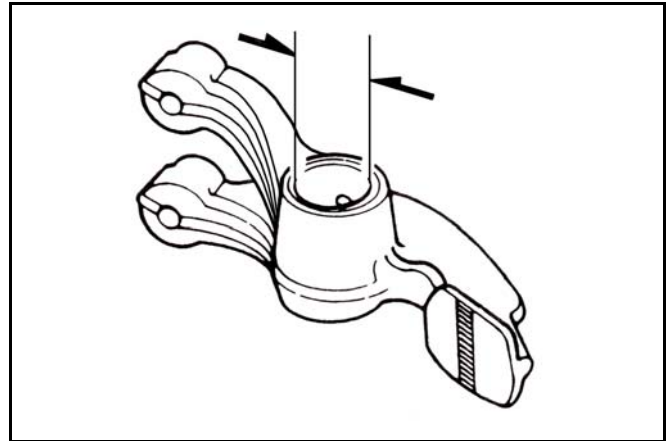

#### Rocker arm shaft

Measure the active outer diameter of the cam rocker arm shaft and cam rocker arm.

**Service limit: 11.936 mm**

Calculate the clearance between rocker arm shaft and rocker arm.

**Service limit: 0.10 mm**

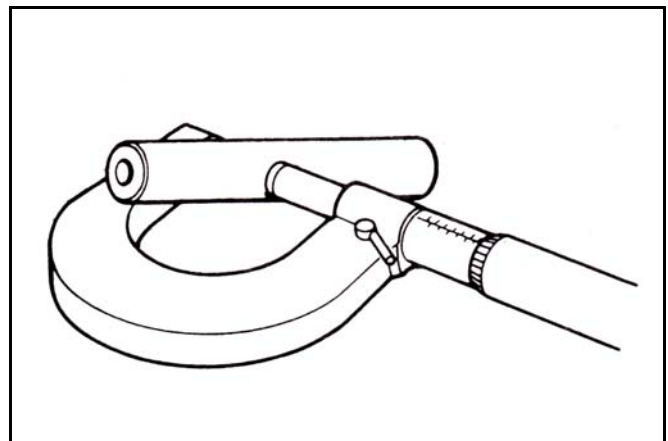

### Valve spring

Measure the free length of intake and exhaust valve springs.

**Service limit:**

**Inner valve spring: 35.20mm**

**Outer valve spring: 36.90mm**

### Valve stem

Check if valve stem bent, burnt, or worn. Check the operation condition of valve stem in valve guide, and measure the valve stem outer diameter.

**Service limit: 4.90 mm**

### Valve guide

#### ⚠ Caution

- Clear all the carbon deposit with reamer before measuring the valve guides.

**Special tool: valve guide reamer 5.0mm**

Measure and record each valve guide inner diameter.

**Service limit: 5.03 mm**

The clearance value is valve guide inner diameter deducts valve stem outer diameter.

**Service limit:**

**Intake valve 0.080 mm**

**Exhaust valve 0.100 mm**

#### ⚠ Caution

- If clearance is over service limit, check if only replacing a new valve guide will fix the clearance into service limit or not. If yes, replace valve guide only.

Fix the guides with reamer after replacement.

If clearance still exceeds service limit after replacing valve guides, please also replace valve stem.

#### ⚠ Caution

- Fix the valve seat when replacing valve guides.

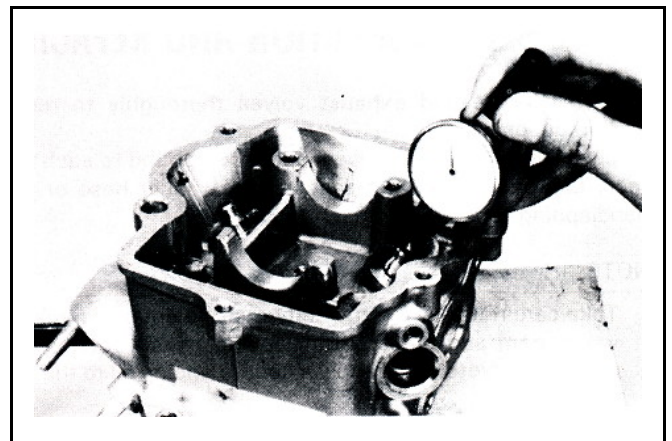
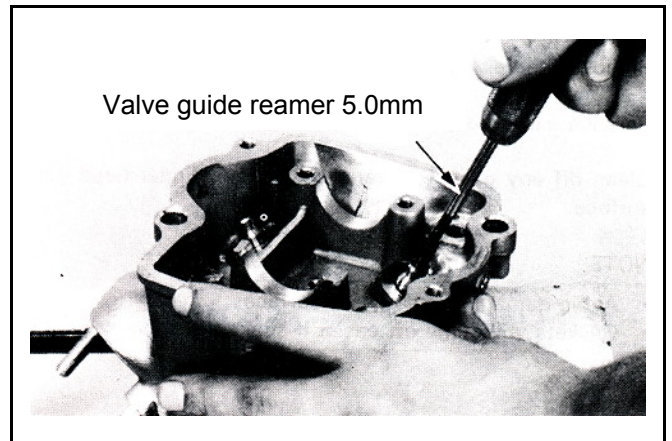
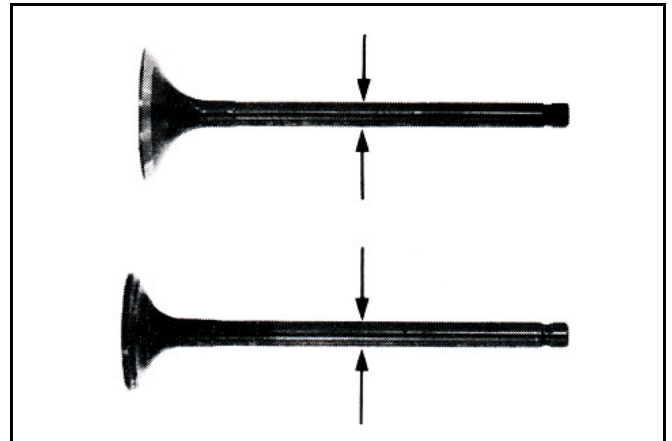
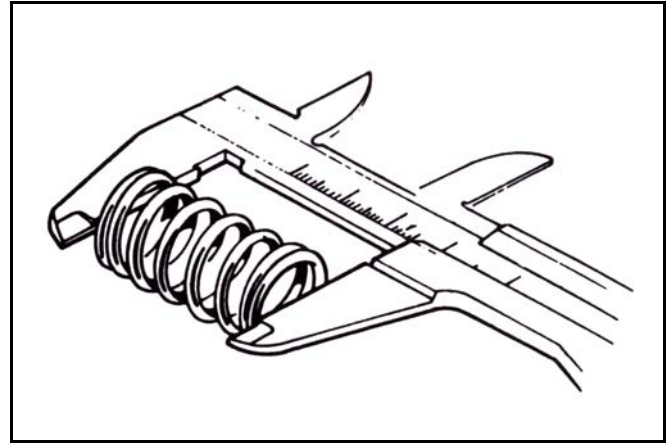

### Valve guide replacement

Heat cylinder head with heating plate or toaster till the temperature reaches 100~150 °C.

#### Caution

- Do not use flame to heat cylinder head directly. Otherwise, cylinder head will be deformed.
- Wear heat insulation gloves to protect your hands when operating.

Hold the cylinder head, and then press out old valve guide from combustion chamber side.

**Tool: valve guide driver 5mm**

#### Caution

- Check if new valve guide deformed after installation.
- When installing new valve guide, keep cylinder head on 100~150°C.

Adjust the valve guide driver and let valve guide height be 13 mm.

Install new valve guide from rocker arm side.

**Tool: valve guide driver 5mm**

After cylinder head cooling down to room temperature, fix the new valve guide with reamer.

#### Caution

- Use cutting oil when fixing valve guide with a reamer.
- When inserting or rotating the reamer, turn it in same direction.

Correct the valve seat, and clean up all metal residues from cylinder head.

**Special tool: valve guide reamer 5mm**

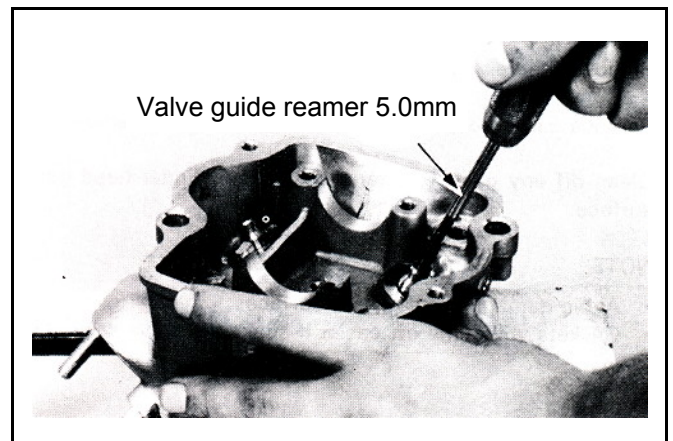
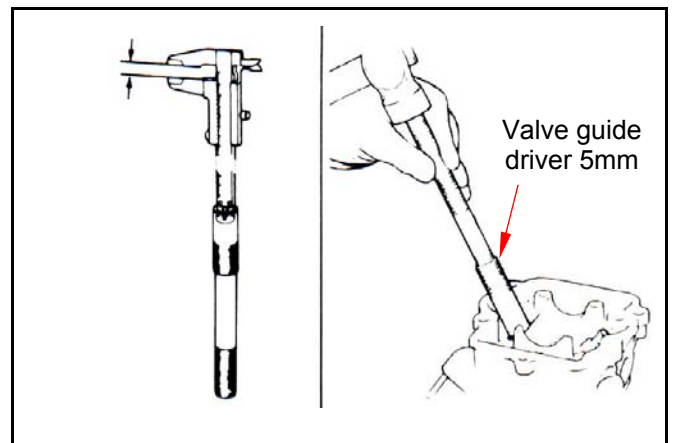
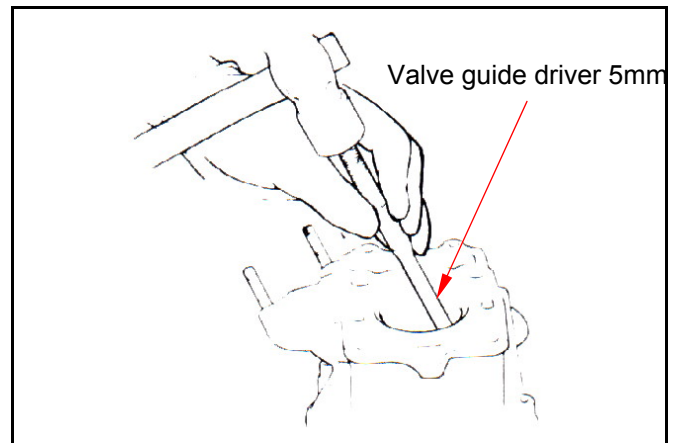

### Valve seat inspection and refacing

Clean up all carbon deposits around intake and exhaust valves.

Apply emery slightly onto valve contact surface. Grind valve seat with grinding tool.

#### ⚠ Caution

- Prevent emery from getting into valve stem and guide.
- After grinding, clean up emery, and apply red lead slightly onto the surface.

Remove valves and check if the contact surface even or not.

#### ⚠ Caution

- The valve cannot be ground and reused. If the valve is burned, worn, or contact surface is uneven, replace it.
- If the valve contacts the valve seat unevenly after grinding, replace it.

### Valve seat inspection

If the valve seat is too wide, too narrow, or worn, re-grind it.

### Valve seat width

**Service limit: 1.6 mm**

Check the contact condition of the valve seat.

### Valve seat grinding

Grind the worn surface with specified valve seat cutter.

Use the 45 degree valve seat cutter to remove any roughness on the valve seat.

#### ⚠ Caution

- Use the 45 degree valve seat cutter to grind the seat after changing the valve guide.

Use the 32 degree cutter to remove the upper 1/4 part of the valve seat.

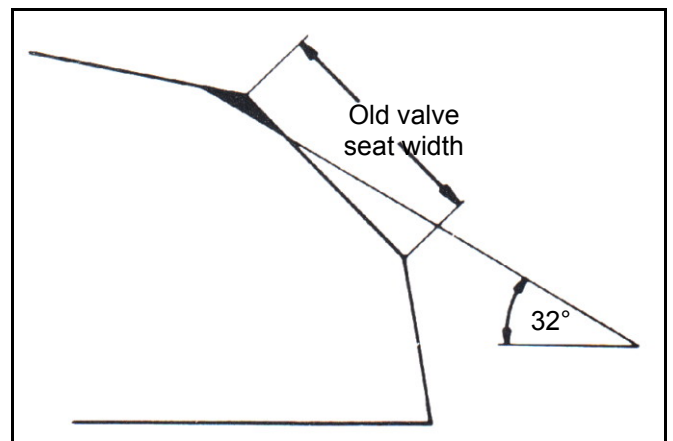
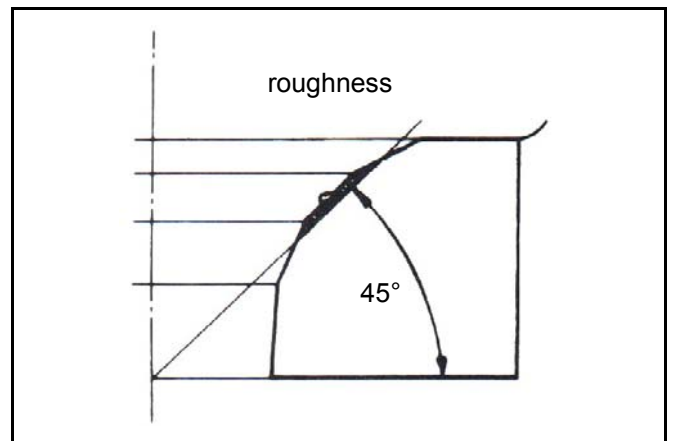
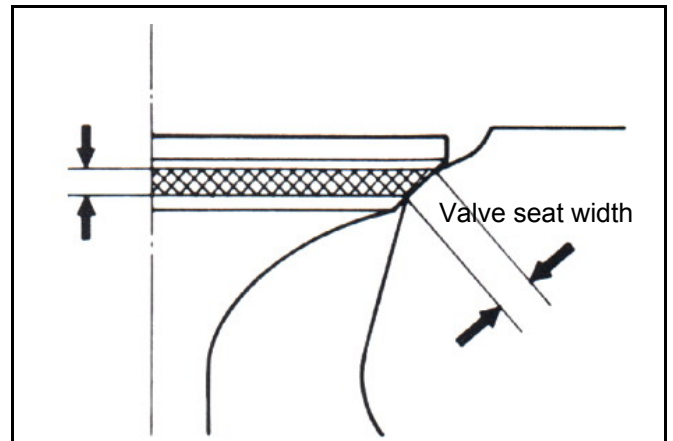
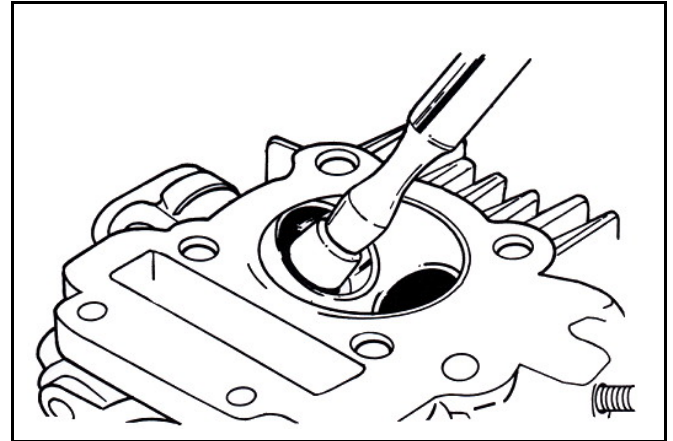

## 7. Cylinder Head / Valve



Use the 60 degree cutter to remove the bottom 1/4 part of the seat and check the new valve seat.

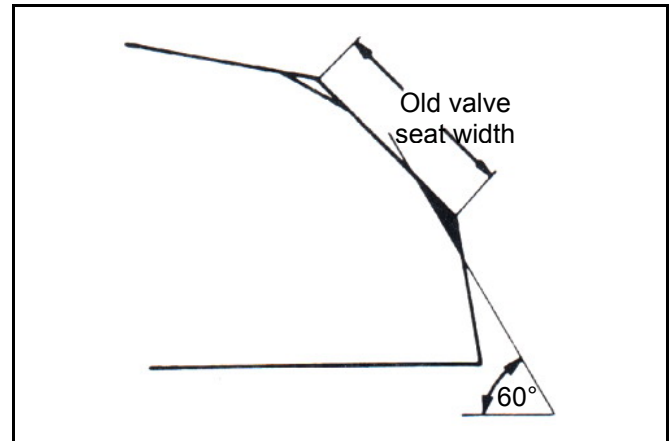

Use the 45 degree cutter to cut the seat to the proper width.

### Caution

- Confirm that all roughness is removed.

Re-grind if necessary.

Coat the valve seat surface with Prussian blue or red lead.

Install the valve through valve guide until the valve contacting with valve seat, slightly press down the valve but do not rotate it so that a seal track will be created on contact surface.

### Caution

- The contact surfaces of valve and valve seat are very important to the valve sealing capacity.

If the contact surface on the valve is too high, cut the valve seat with the 32 degree cutter. Then cut the valve seat to the proper width with the 45 degree cutter.

If the contact surface on the valve is too low, cut the valve seat with the 60 degree cutter. Then cut the valve seat to the proper width with the 45 degree cutter.

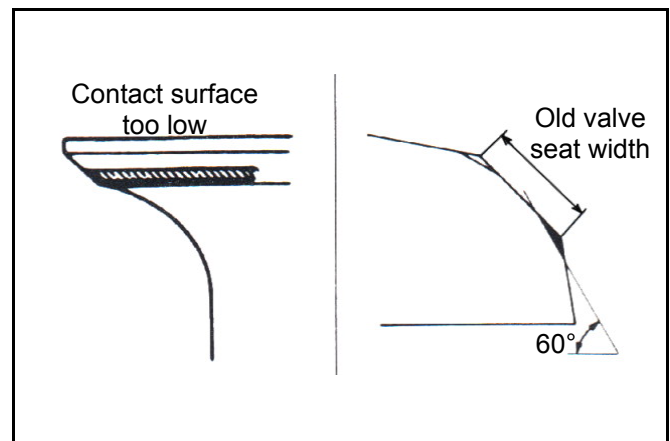
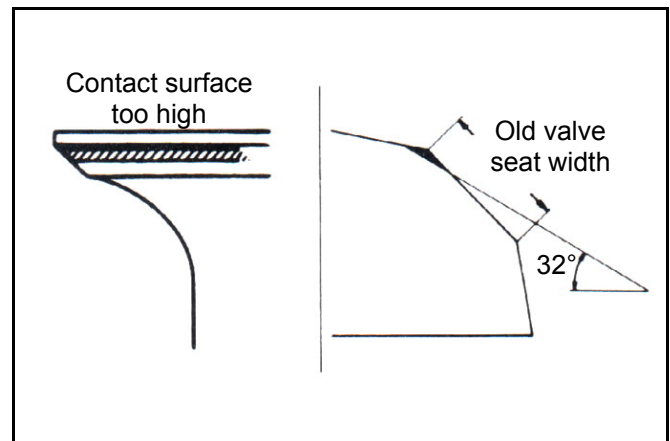
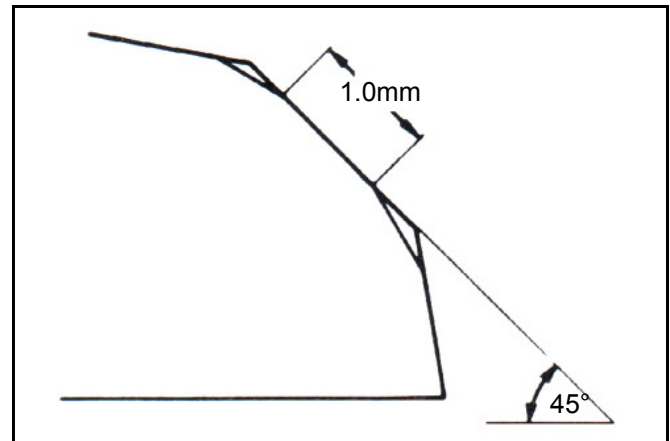

After grinding, apply emery slightly onto valve contact surface. Grind valve seat with grinding tool.

Clean up emery covered on the cylinder head and valve.

### Cylinder head assembly

Lubricate valve stem with engine oil, then insert it to valve guide.

Install new valve stem oil seal.

Install valve spring and valve spring retainer.

#### Caution

- The dense end of valve spring should face down to combustion chamber.

Install valve by valve spring assemble / disassemble tool.

#### Special Tool:

Valve Spring Assemble/Disassemble Tool  
**SYM-1471110**

#### Caution

- When installing springs, place cloth in combustion chamber to hold the valves avoiding bending the valve.

Slightly tap the valve stem with a plastic hammer to secure the valve cotter.

#### Caution

- Hold cylinder head on a working table to avoid damaging the valve.

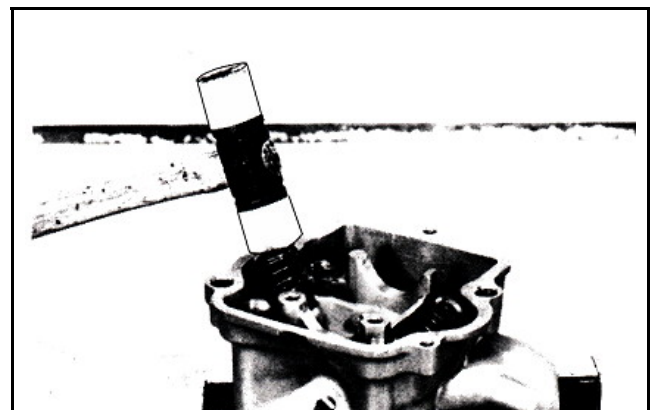
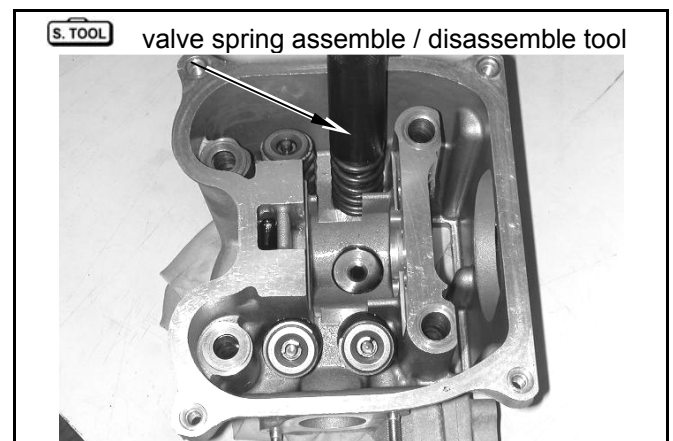
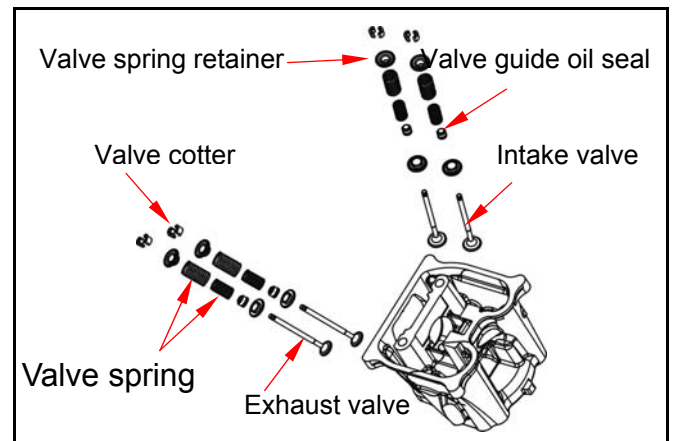
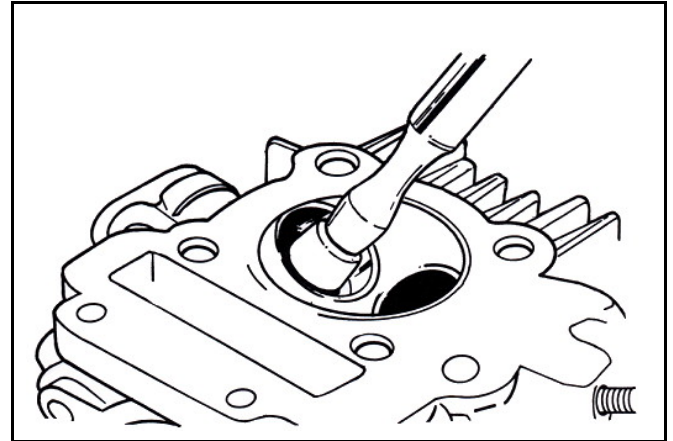

## 7. Cylinder Head / Valve



Install camshaft into cylinder head. Install valve rocker arm, rocker arm shaft and rocker arm shaft holding plate.

### Cylinder head installation

Clean up foreign materials on the matching surfaces of cylinder and cylinder head.

Install cam chain guide.

Install new dowel pins and gasket on the cylinder.

#### Caution

- Do not damage matching surfaces.
- Prevent foreign material from falling into the crankcase.

Install cylinder head.

Tighten the 4 cylinder head nuts, then the 2 bolts on right side of cylinder head.

#### Torque value:

**Cylinder head nut**                    **3.6~4.0kgf-m**

**Bolt on right side of cylinder head**  
**1.0~1.4kgf-m**

#### Caution

- Lubricate with engine oil and tighten the cylinder head nuts in diagonally opposite sequence.
- Do not exceed the specified torque value to prevent damaged cylinder head, abnormal noise, leakage or poor engine performance.

Rotate the crankshaft counterclockwise and align the "T" mark on the flywheel with the index mark on the left crankcase cover. (The piston is on the top dead center.)

Install the cam chain sprocket and sprocket, align the timing mark with the index mark on the cylinder head.

Tighten sprocket bolt. (bolt×2)

**Torque value: 1.0~1.4kgf-m**

Install spark plug.

**Torque value: 1.0~1.2kgf-m**

#### Caution

- Make sure aligning the timing mark.

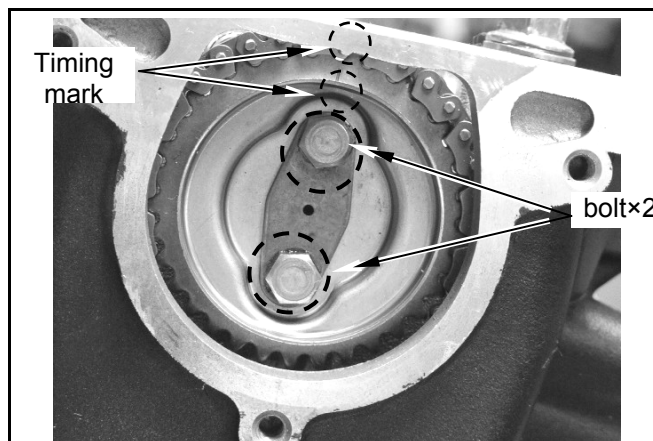
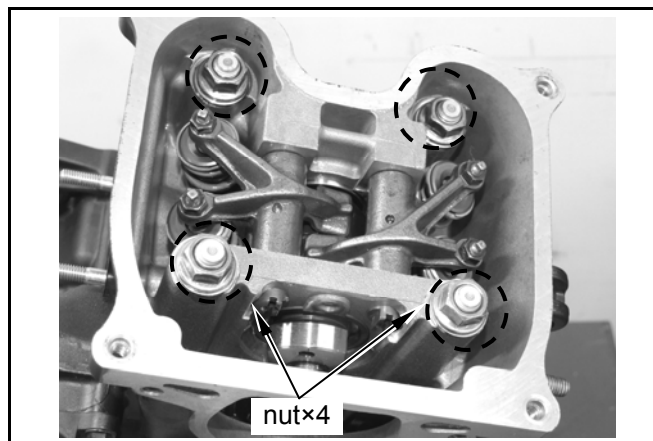
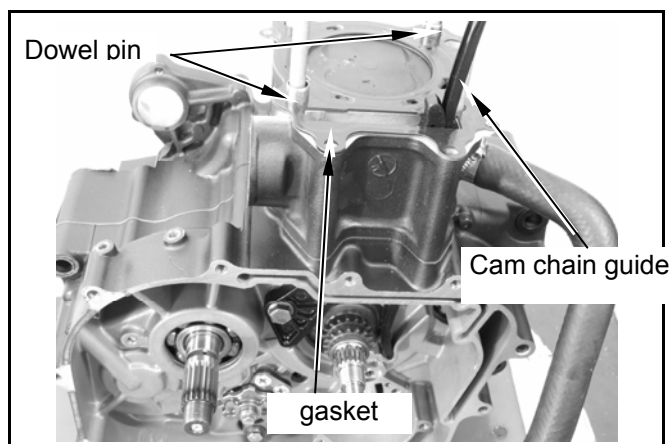
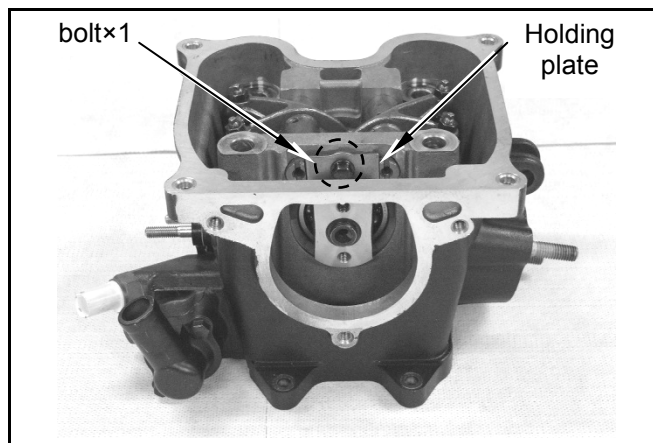



Install cylinder head side cover. (bolt×3)。

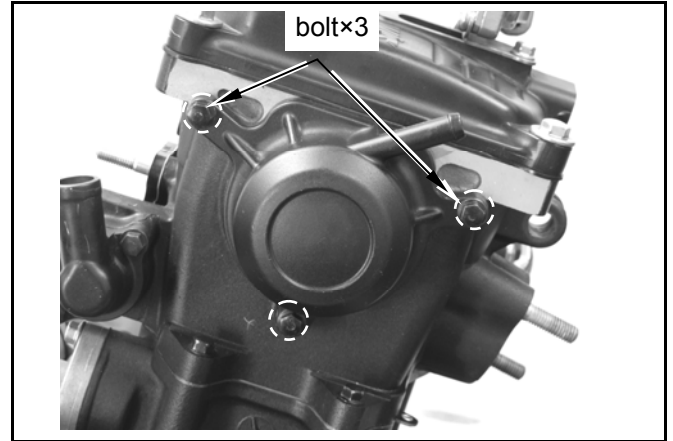

Install thermostat. (bolt×2)。

Loosen cam chain auto-tensioner adjusting bolt, remove the spring.

Install auto-tensioner (bolt×2), then install the spring and adjusting bolt.

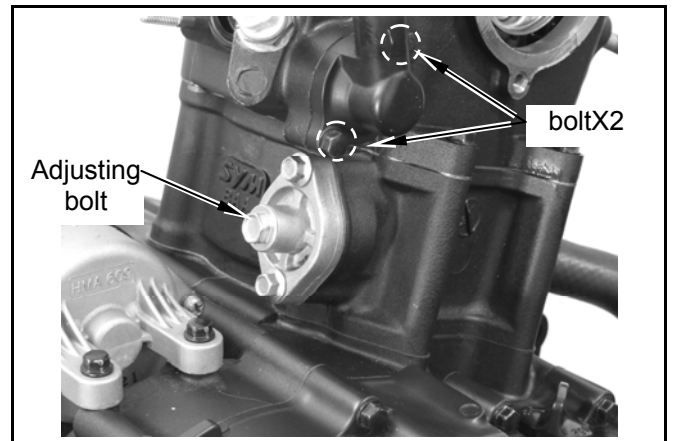

Install cylinder head cover. (bolt×4)

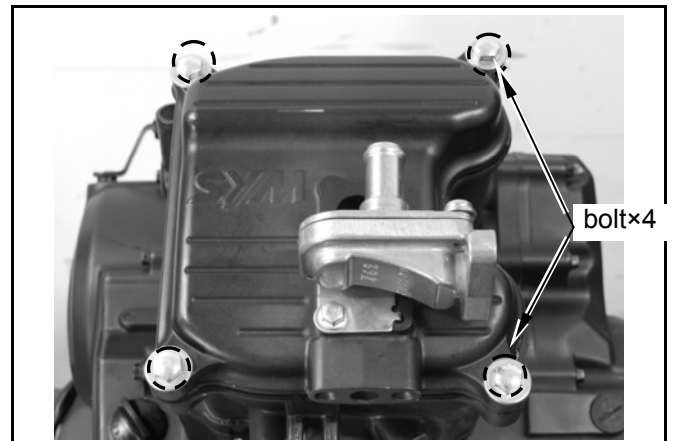

Install AI pipe (bolt×4)

Install spark plug.

**Torque value: 1.0~1.2kgf-m**

Install the engine onto the frame. (refer to 6<sup>th</sup> chapter)

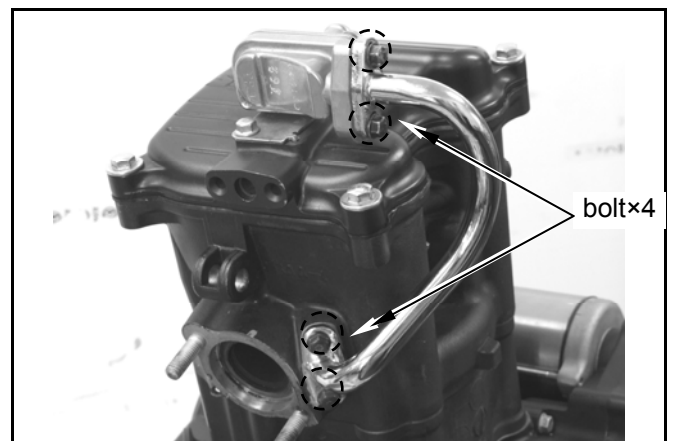

## 7. Cylinder Head / Valve



### Valve clearance adjustment

Remove AI pipe. (bolt×4)。

Remove cylinder head cover. (bolt×4)。

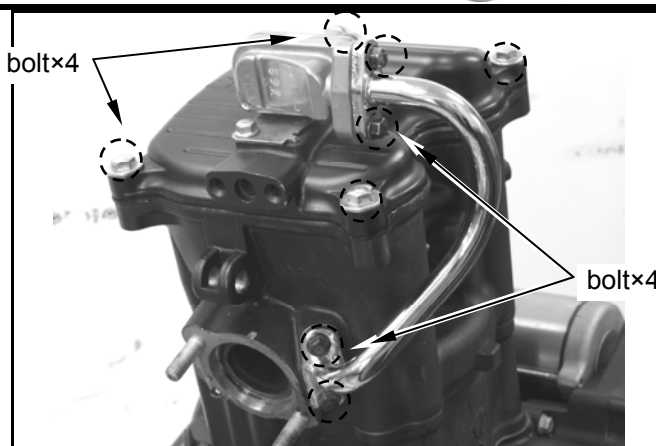

Remove cylinder head side cover. (bolt×3)。

Remove timing-inspecting hole cap.  
Remove ACG cap, rotate the crankshaft counterclockwise and align the “T” mark on the flywheel with the index mark on the left crankcase cover. Align the cam sprocket timing mark with the index mark on the cylinder head.

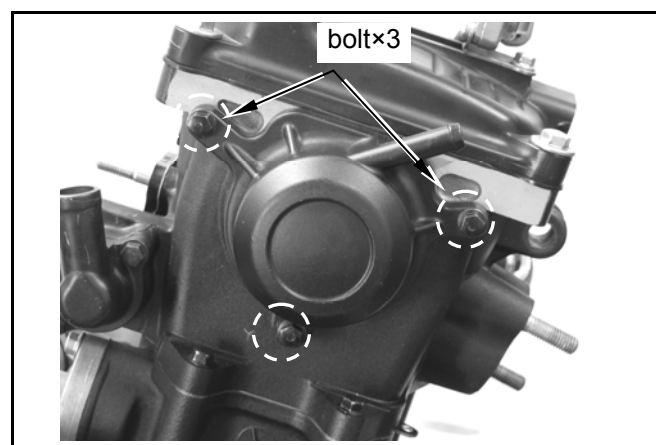

Loosen the fixing nut and rotate the adjusting bolt to adjust valve clearance.  
Fasten the adjusting bolt and tighten the fixing nut when the standard value is reached.

**Valve clearance: In  $0.10 \pm 0.02$  mm**

**Ex  $0.15 \pm 0.02$  mm**

Install cylinder head side cover. (bolt×3)  
Start the engine, make sure engine oil pumped up to cylinder head, then shut off the engine immediately.

Install cylinder head cover. (bolt×4)

Install AI pipe. (bolt×4)

#### **Caution**

- Cylinder head parts will be seriously damaged, if engine oil does not lubricate properly.
- Check the lubrication condition while idling, do not rise R.P.M.

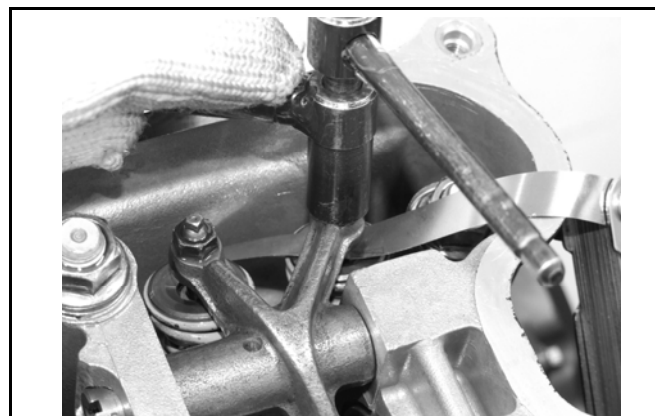
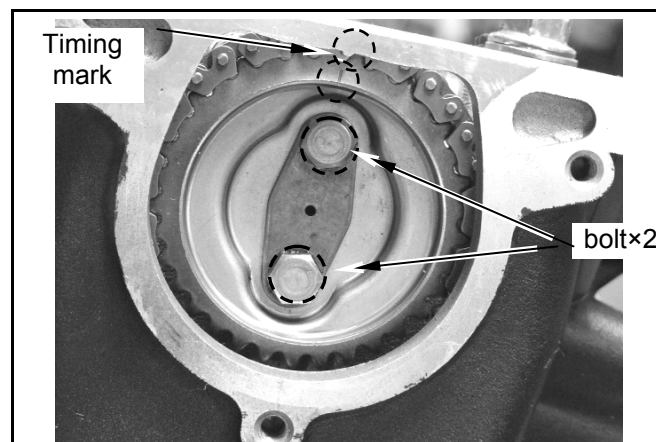

Mechanism Diagram .....8-1	Piston Removal / Inspection .....8-5
Precautions in Operation .....8-2	Piston Rings Installation .....8-8
Troubleshooting .....8-2	Piston Installation .....8-9
Cylinder Removal / Inspection ...8-3	Cylinder Installation .....8-10

## Mechanism diagram

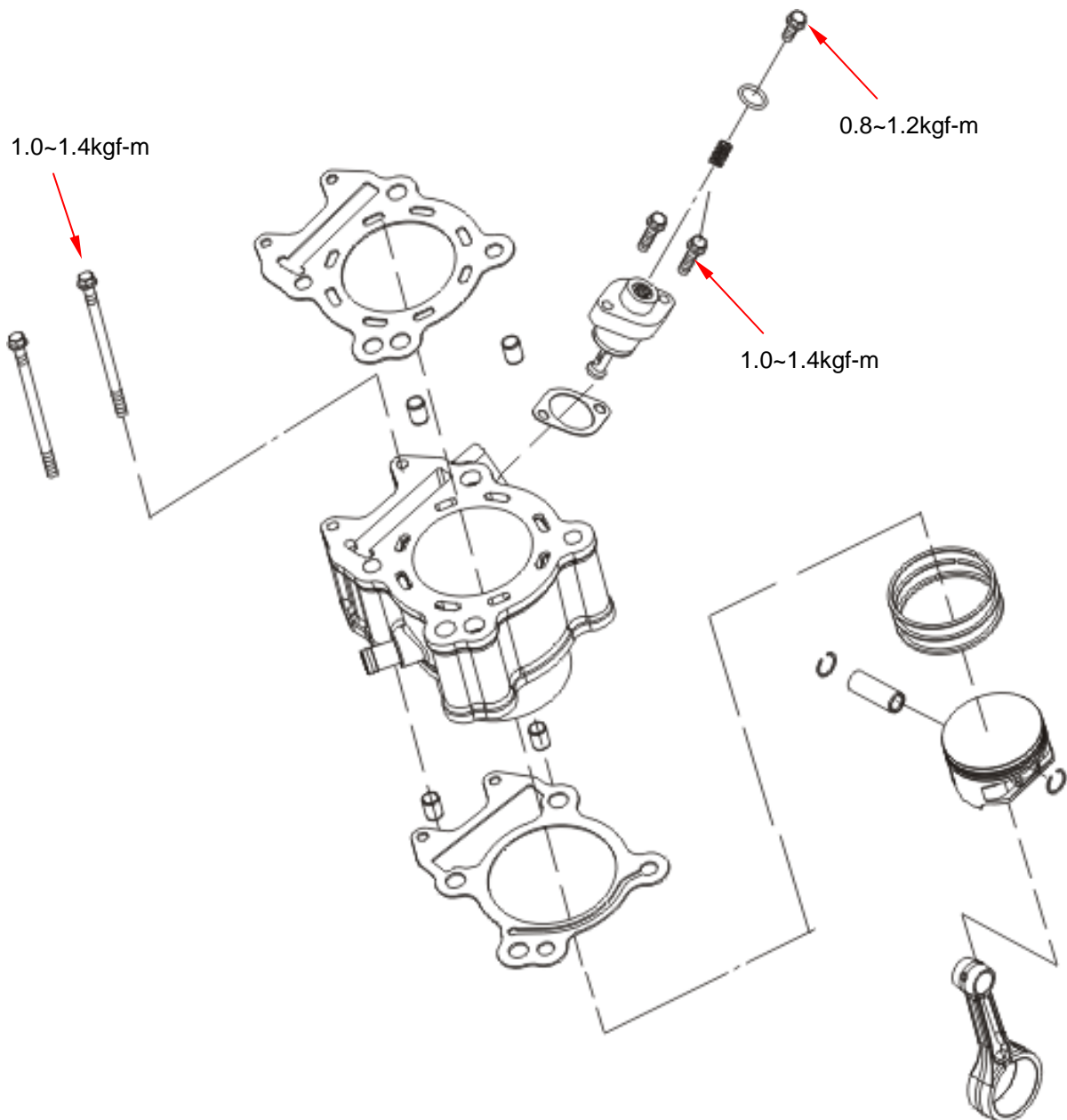

### Precautions in operation

#### General information

- The engine must be removed from the frame before repairing cylinder and piston.

#### Specification

Measurement: mm

Item		Standard	Service limit	
Cylinder	Inside Diameter	70.995~71.015	71.100	
	Warpage	-	0.050	
	Taper	-	0.050	
	Out of round	-	0.050	
Piston / Piston Ring	Piston Ring / Groove Clearance	Top Ring	0.015~0.050	
		Second Ring	0.015~0.050	
	Piston Ring End Gap	Top Ring	0.150~0.300	
		Second Ring	0.300~0.450	
		Oil Ring	0.200~0.700	
	Piston Ring Thickness	Top Ring	1.475~1.490	
		Second Ring	1.475~1.490	
	Piston Outside Diameter		70.430~70.480	70.380
	Piston/ Cylinder Clearance		0.010~0.040	0.100
	Piston Pin Hole Inside Diameter		17.002~17.008	17.020
Piston Pin Outside Diameter		16.994~17.000	16.960	
Piston/ Piston Pin Clearance		0.002~0.014	0.020	
Connecting Rod Small End Inside		17.016~17.034	17.064	

### Troubleshooting

#### Low Compression or Instability

Worn cylinder or piston rings

#### Over High Compression

Excessive carbon built-up on the piston or combustion chamber

#### Knocking or Abnormal Noise

Worn piston or cylinder

Excessive carbon built-up on the top of the piston

Worn Piston Pin and Piston Pin Hole

#### Excessive Smoke

Worn cylinder, piston, or piston rings  
Improper piston rings installation  
Worn cylinder or piston rings

#### Overheating

Excessive carbon built-up on the top of the piston

### Cylinder removal / inspection

Remove the cylinder head. (refer to chapter 7)  
Remove cylinder head gasket and dowel pins.  
Remove cam chain guide.

Remove cylinder.

#### Caution

- Prevent cam chain from falling into crankcase when removing cylinder.

Remove cylinder gasket and dowel pins.

Clean all the gasket material from the contact surface.

#### Caution

- Use solvent to wet the gasket material in order to remove it more easily.
- Do not damage the contact surface during operation.

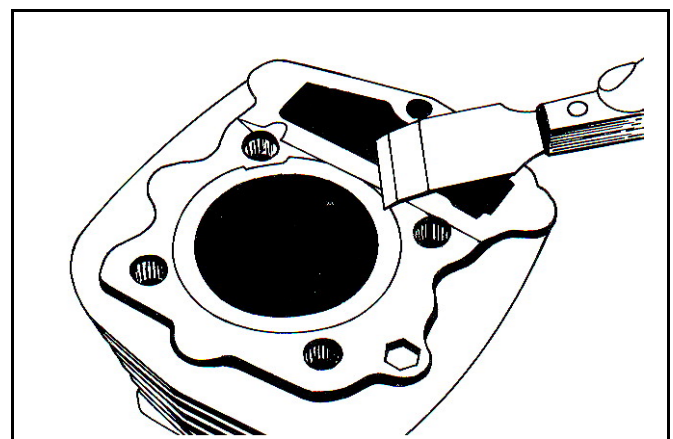
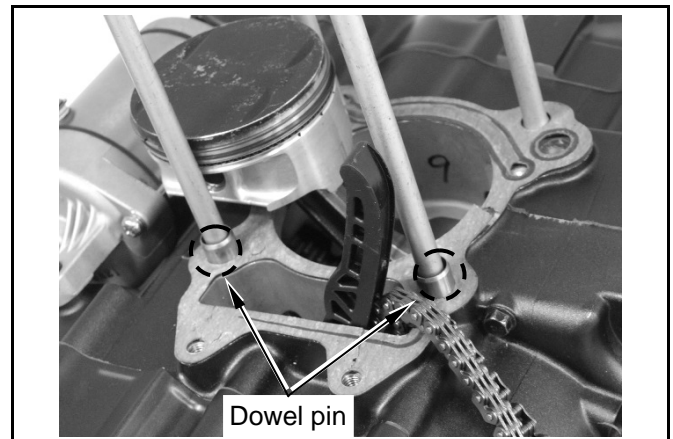
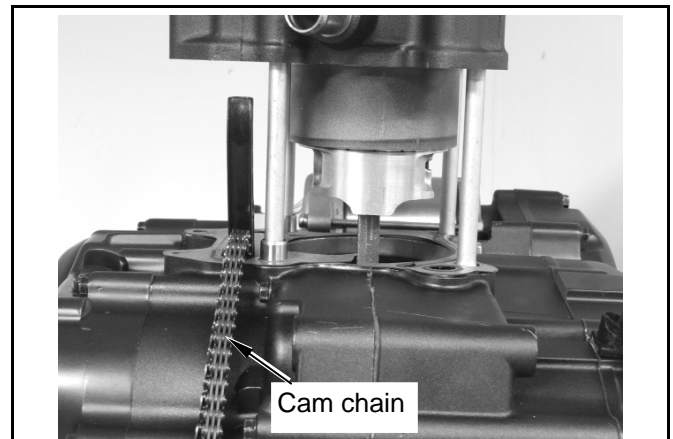
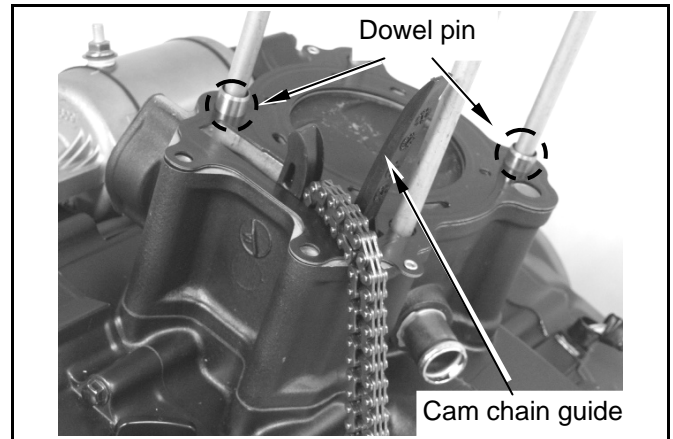

## 8. Cylinder / Piston



### Cylinder inspection

Check if the inner diameter of cylinder is worn out or damaged.

Measure the cylinder inner diameter in X and Y axis at three levels.

**Service limit: 71.10 mm**

Calculate the taper and out of round at three levels in X and Y axis. Take the maximum value to determine.

**Service limit:**

**Out of round : correct or replace if over 0.05 mm**

**Taper : correct or replace if over 0.05 mm**

Measure the cylinder upper surface for warpage.

**Service limit: correct or replace if over 0.05mm**

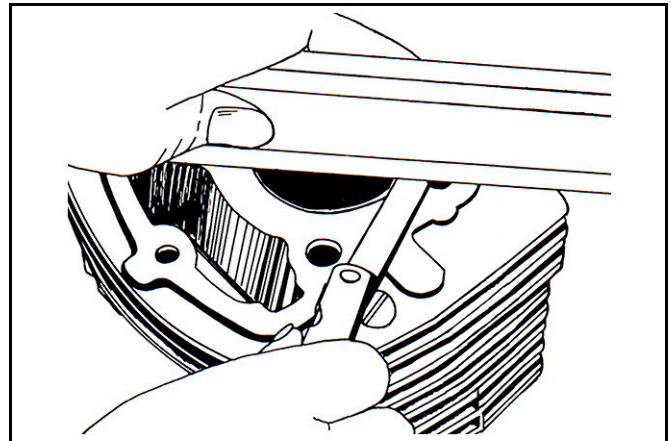
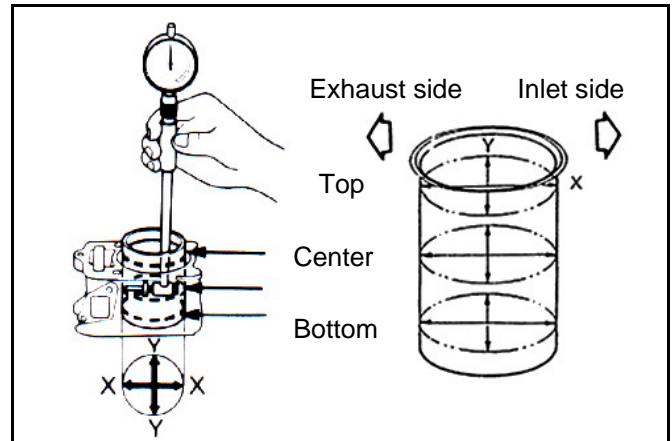

### Piston removal / inspection

Block the crankcase and camshaft chain hole with a clean cloth to prevent the piston pin clip from falling into the crankcase.

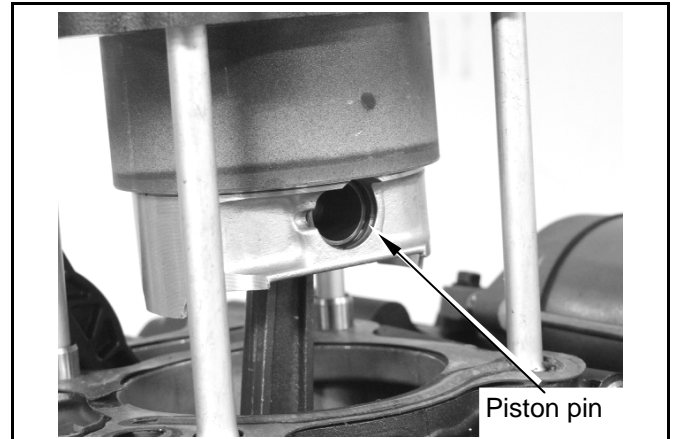

Remove the piston pin circlip and remove the piston pin and piston.



Remove piston rings.

#### Caution

- Piston rings are easy to break, please be careful during operation

Check if the piston rings are damaged or the grooves are worn. Clean the carbon deposit.

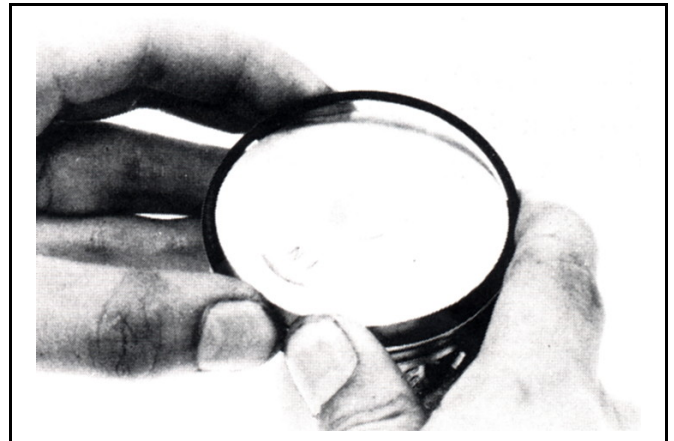

Measure the clearance between piston rings and ring grooves

#### Service limit :

**Top groove: replace if over 0.13 mm**

**Second groove: replace if over 0.12 mm**

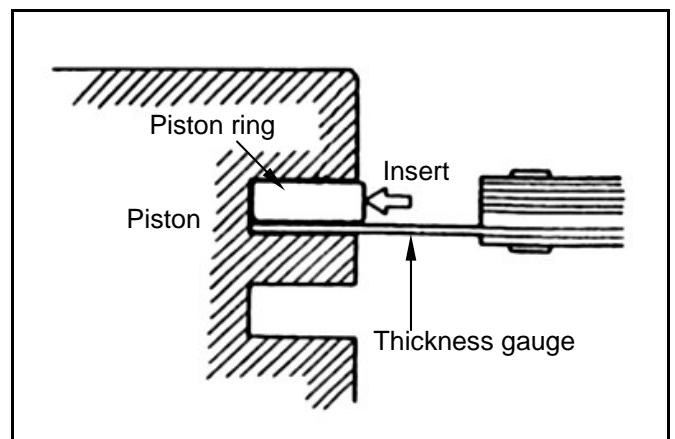

## 8. Cylinder / Piston



Install piston rings respectively into cylinder 20 mm below cylinder top.  
Measure the piston ring end gap.

### Caution

- Use the piston head to push the piston rings squarely into the cylinder.

**Service limit :**

**Top ring : replace if over 0.5 mm**

**Second ring : replace if over 0.65 mm**

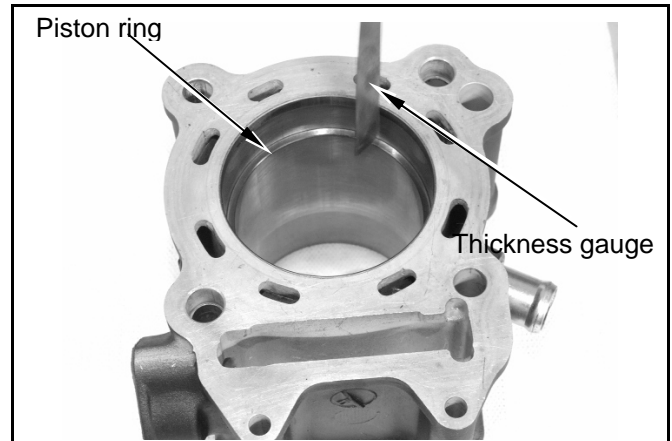

Measure the piston pin outer diameter.

**Service limit: 16.96mm**

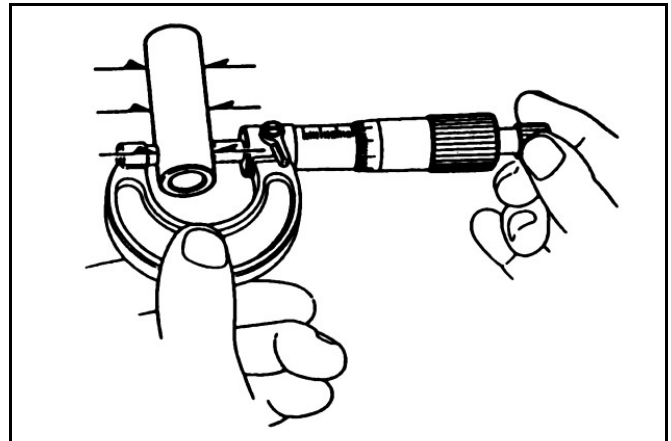

Measure the conrod small end inner diameter.

**Service limit: 17.064mm**

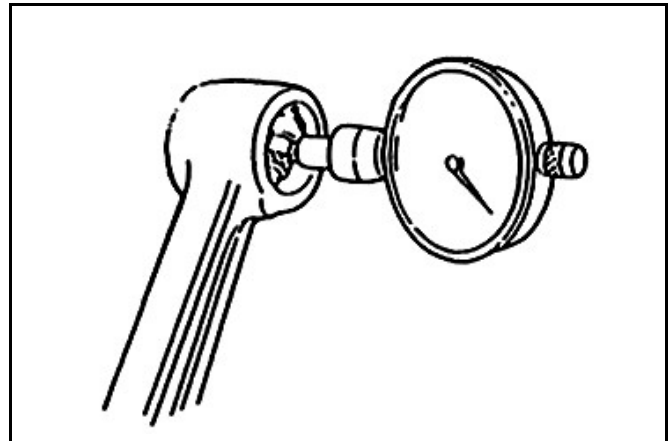

Measure the inner diameter of piston pin hole.

**Service limit: 17.020mm**

Calculate the clearance between the piston pin and its hole.

**Service limit: 0.02mm**

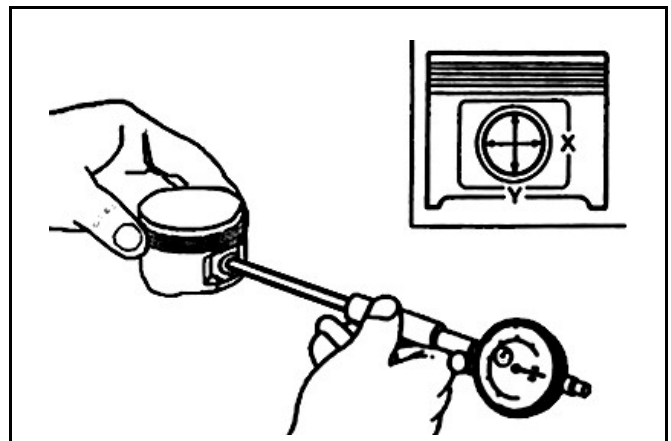



Measure the outer diameter of piston pin.

**⚠ Caution**

- Measure the piston outer diameter in the direction perpendicular to the piston pin axis.

**Service limit: 70.38 mm**

Compare the measured value with service limit to calculate the clearance between the piston and cylinder.

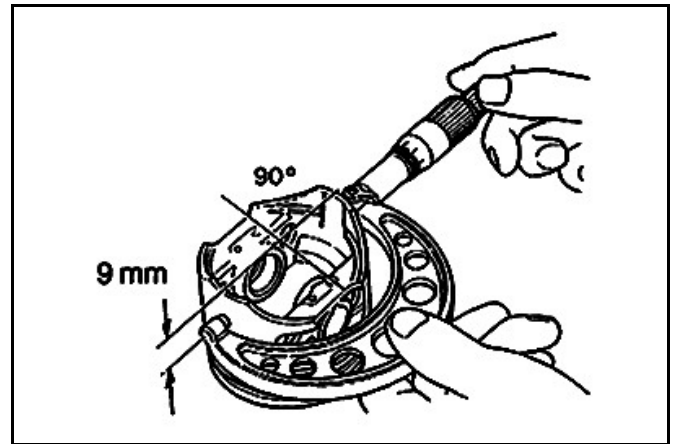

Measure piston ring thickness.

**Service limit: 1.46mm**

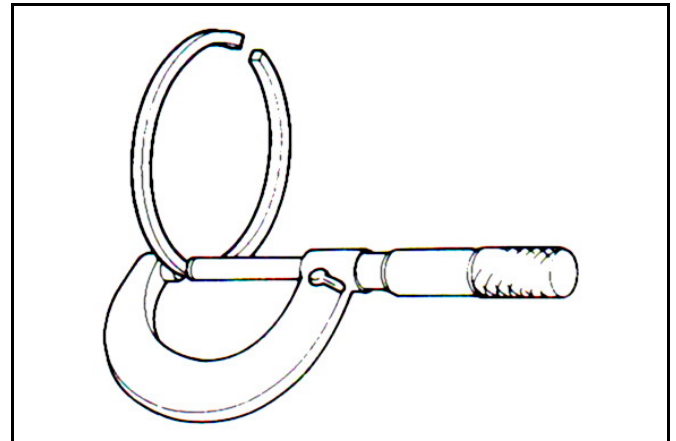

### Piston rings installation

Clean up the piston top, ring groove, and piston surface.

Install the piston ring onto piston carefully.

Place the openings of piston rings as diagram shown below.

#### Caution

- Do not damage the piston and piston rings as installation.
- All marks on the piston rings must be forwarded to up side.
- Make sure that all piston rings can be rotated freely after installation.

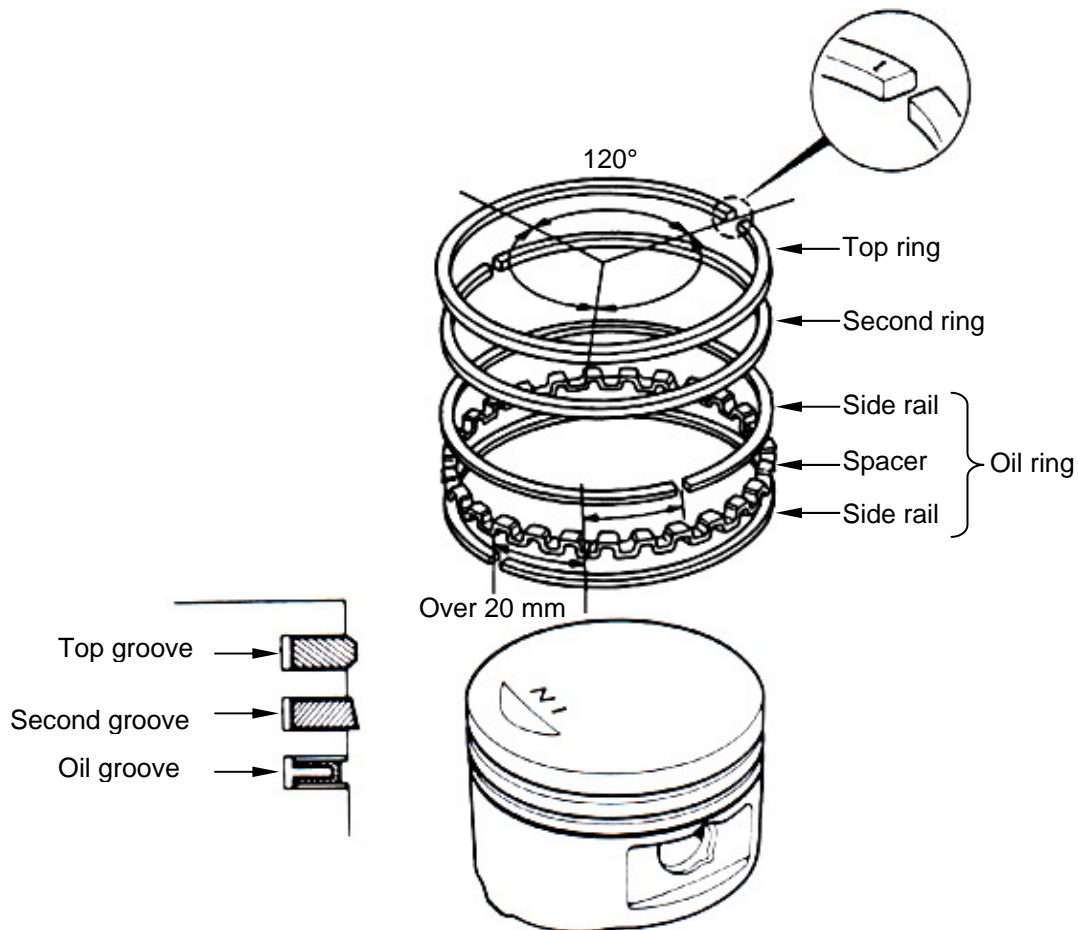

### Piston installation

Place a piece of clean rag under the piston. Clean all the gasket material from the contact surface.

#### Caution

- Use solvent to wet the gasket material in order to remove it more easily.

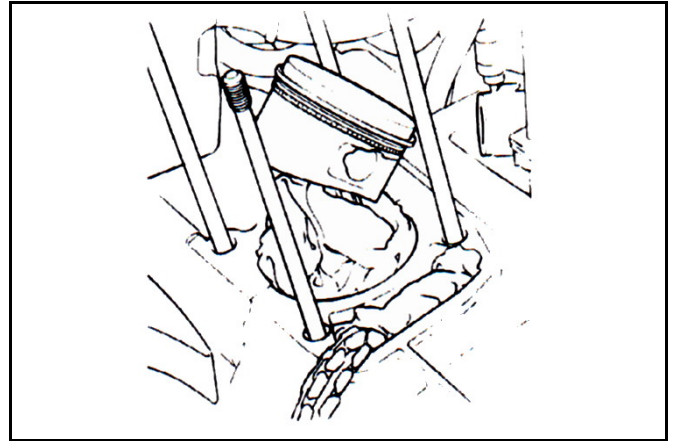

Install piston and piston pin and make the IN mark facing the inlet side.

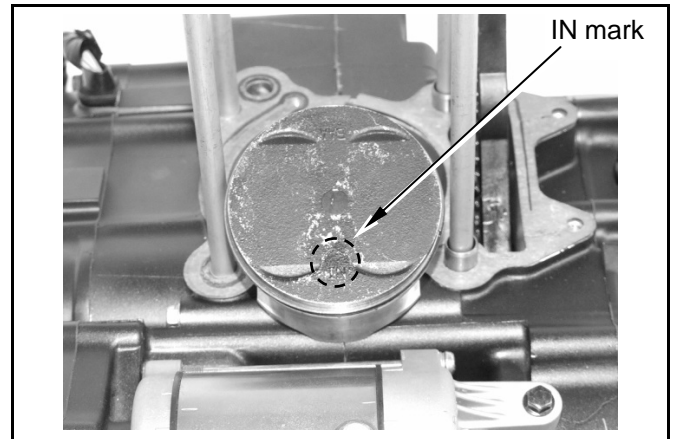

Install the new piston pin circlip.

#### Caution

- Do not make the piston pin circlip opening coincide with the slit of the piston pin hole.
- Place a clean cloth between the piston and the crankcase to prevent the piston pin circlip from falling into the crankcase.

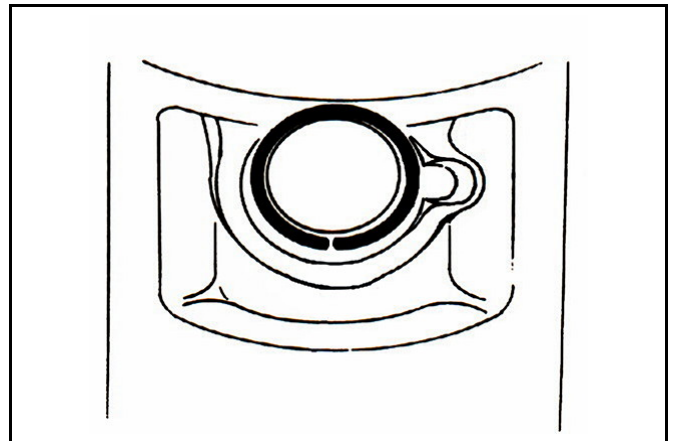

### Cylinder installation

Install dowel pins and new cylinder gasket.

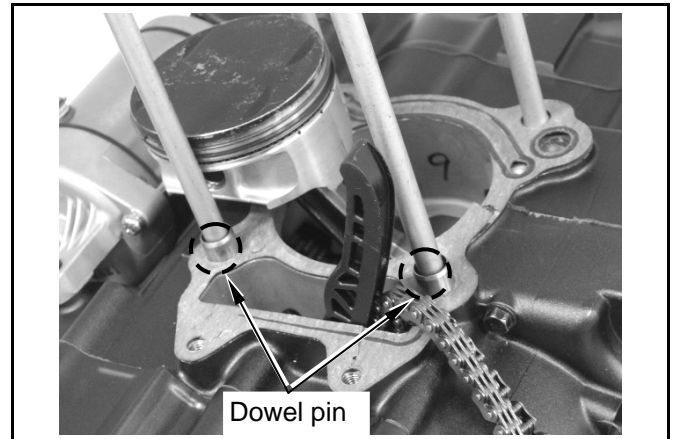

Apply clean engine oil to the cylinder bore, piston and piston rings.  
Install the cylinder carefully. Press the piston rings respectively when installing.

#### **Caution**

- Do not force the piston into the cylinder because the piston and piston rings will be damaged.

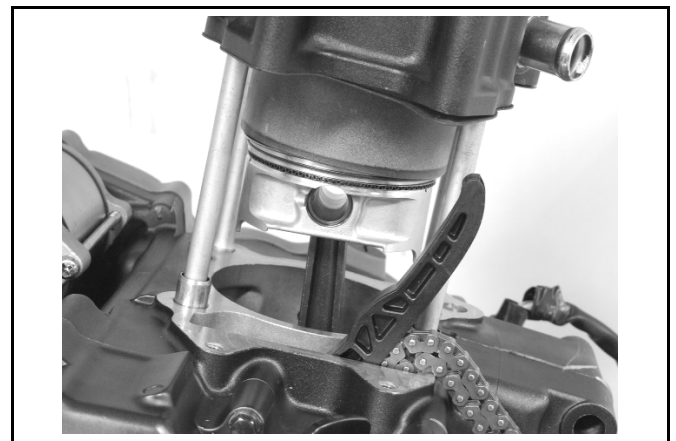

Install the cam chain guide, dowel pins and cylinder head gasket.  
Install the cylinder head. (refer to chapter 7)

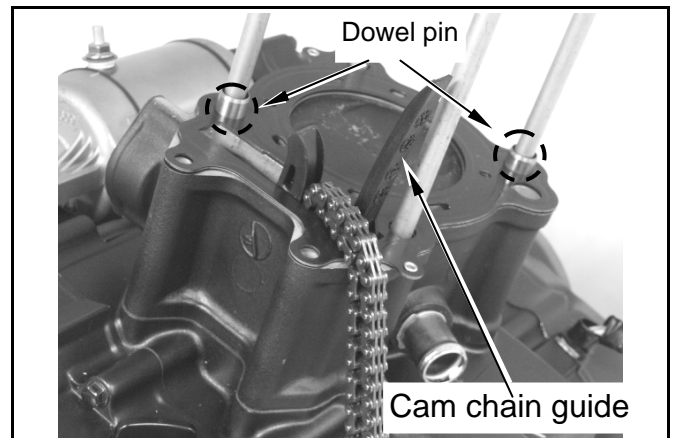

Mechanism Diagram .....	9-1	Transmission Disassembly.....	9-8
Precautions in Operation.....	9-3	Transmission Inspection.....	9-9
Troubleshooting .....	9-4	Crankcase Inspection.....	9-10
Crankcase Disassembly .....	9-5	Crankcase Assembly.....	9-11
Crankshaft Inspection.....	9-7		

## Mechanism diagram Crankcase / crankshaft

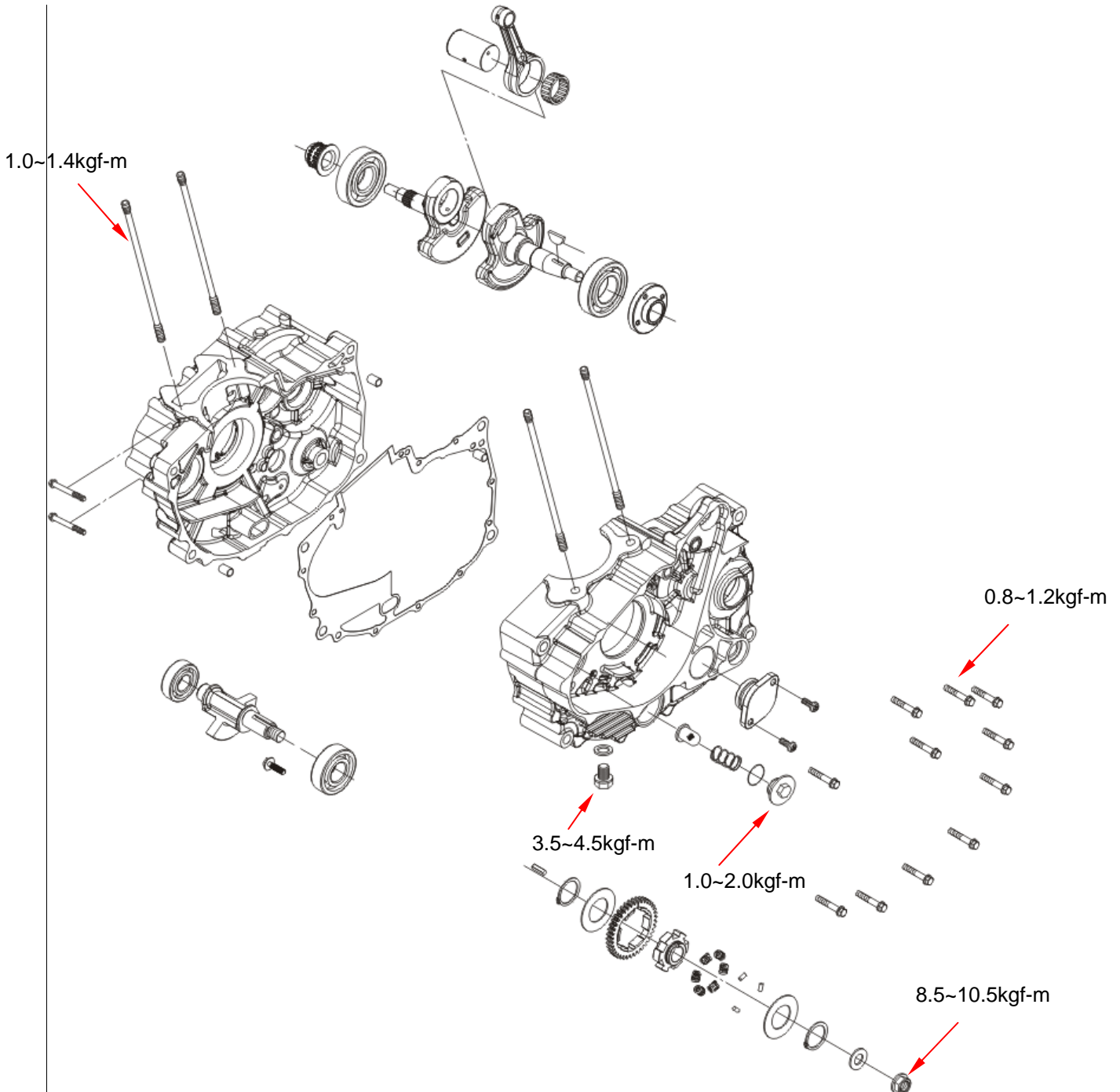

## Transmission

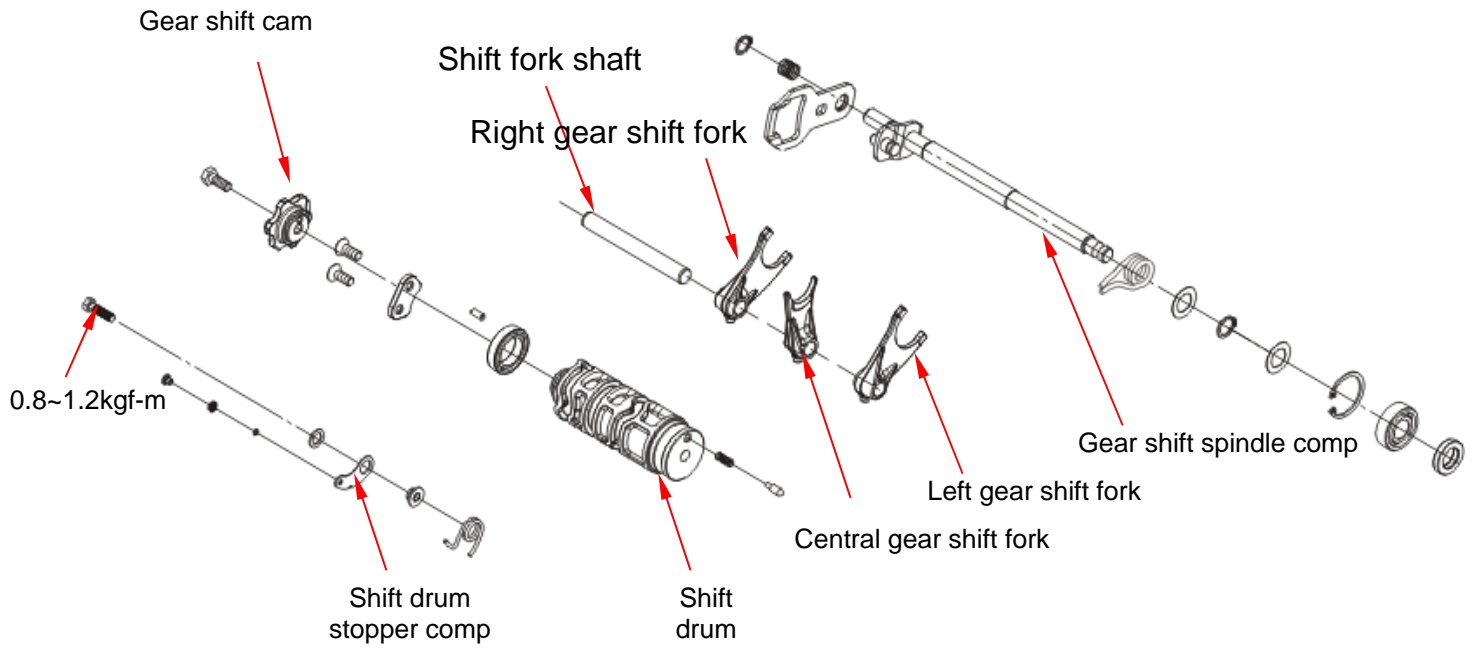

## Six-speed gear

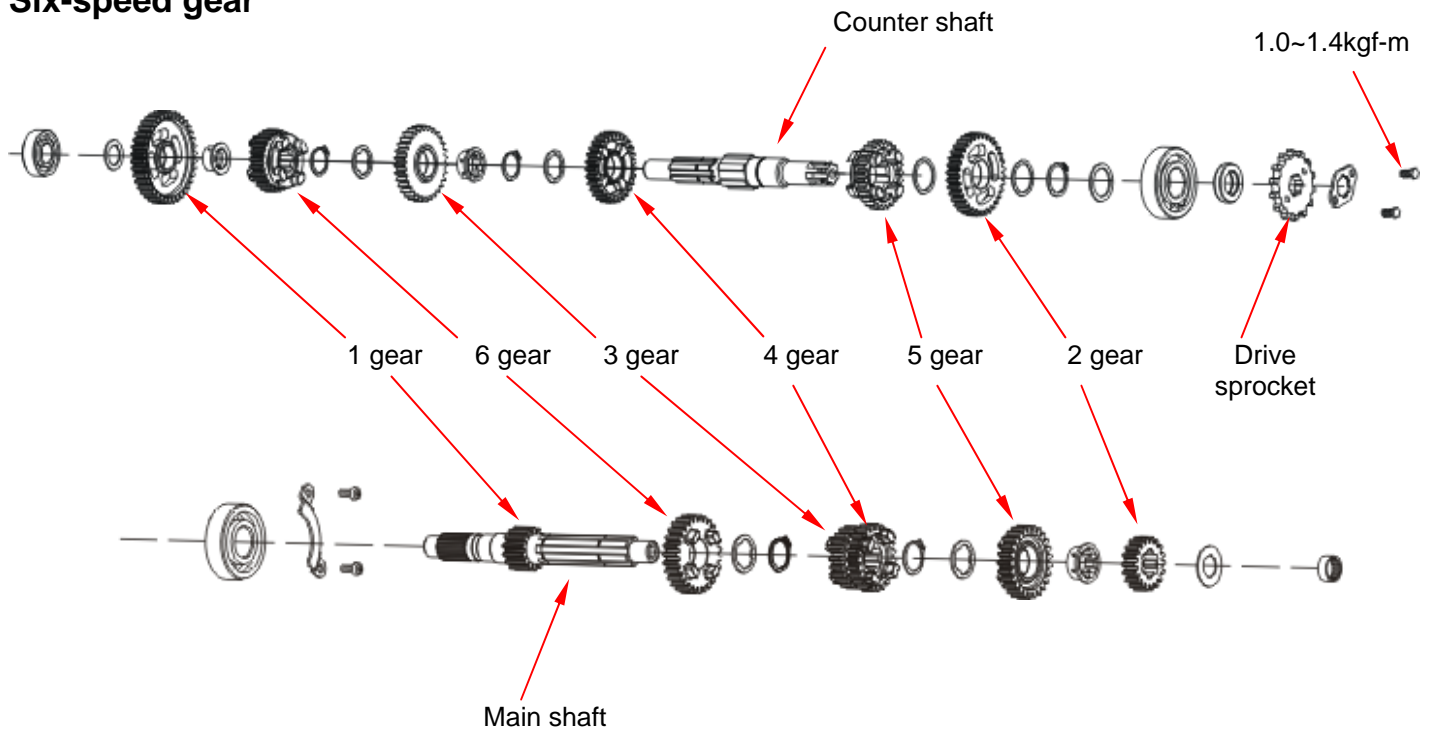

### Precautions in operation

#### General information

- This chapter concerns disassembly of the crankcase, transmission system, and balancing shaft for repair purpose.
- The following components need to be removed before disassembling the crankcase.
 

Engine	Chapter 6
Cylinder head	Chapter 7
Cylinder / piston	Chapter 8
Clutch / Oil Pump / Gear Shift Spindle	Chapter 4
ACG / Starter Clutch / Starter Motor	Chapter 5
- The crankshaft should be replaced as a unit if the timing sprocket or the crankshaft bearing needs to be replaced.

#### Specification

measurement : mm

Item		Standard	Service limit
Crankshaft	Conrod big end side clearance	0.050~0.300	0.600
	Conrod big end vertical clearance	0.004~0.012	0.050
	Run-out	—	0.100
	Conrod small end inner diameter	17.016~17.034	17.064
Gear shift fork	Inner diameter	12.000~12.018	12.050
	Claw thickness	4.930~5.000	4.700
Shift fork shaft	Outer diameter	11.976~11.994	11.960

#### Torque value

Crankcase bolt	0.8~1.2kgf-m
Cylinder / cylinder head bolt	1.0~1.4kgf-m
Engine oil drain bolt	3.5~4.5kgf-m
Oil strainer cover	1.0~2.0kgf-m
Gear switch bolt	0.7~1.1kgf-m

#### Special tools

Inner bearing puller	SYM-6204025
Bearing driver 6204	SYM-6204024
Bearing driver 6301	SYM-6204024
Bearing driver 6203/6004	SYM-6204024

### Troubleshooting

#### Excessive engine noise

- Worn conrod big end
- Worn crankshaft bearing
- Worn piston pin or piston pin hole

#### Hard to shift gear

- Bent shift fork
- Bent shift fork shaft

#### Gear jumps out

- Worn gear teeth
- Bent or damaged shift fork
- Bent shift fork shaft

#### Excessive gear noise

- Worn gear teeth
- Worn gear shaft



### Crankcase disassembly

Remove the 6mm bolt from right crankcase.  
(boltX2)

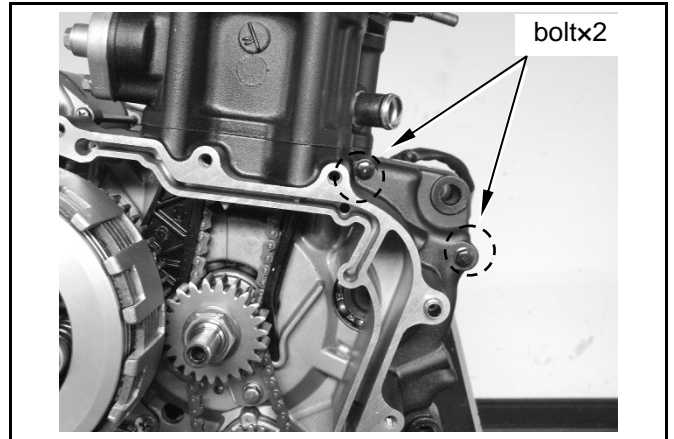

Remove the cam chain tensioner arm from  
right crankcase. (boltX1)  
Remove cam chain.

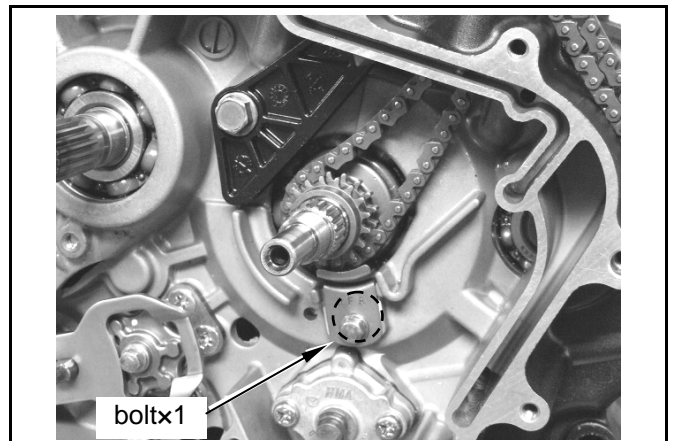

Remove balancing shaft lock nut and fix circlip  
from left crankcase.  
Remove balancing shaft gear.

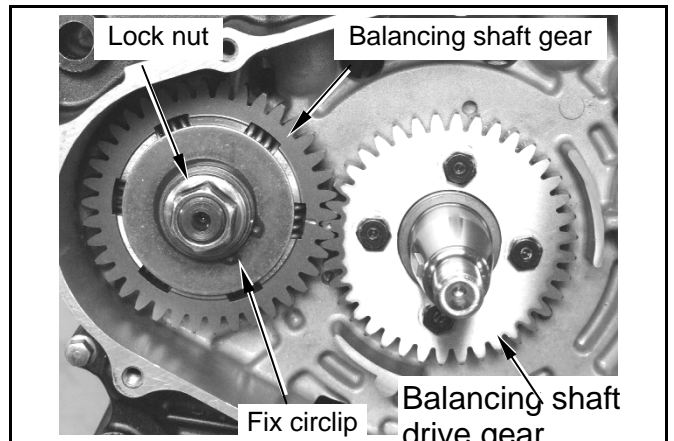

Remove balancing shaft drive gear bolt.  
(boltX4)  
Remove balancing shaft drive gear.

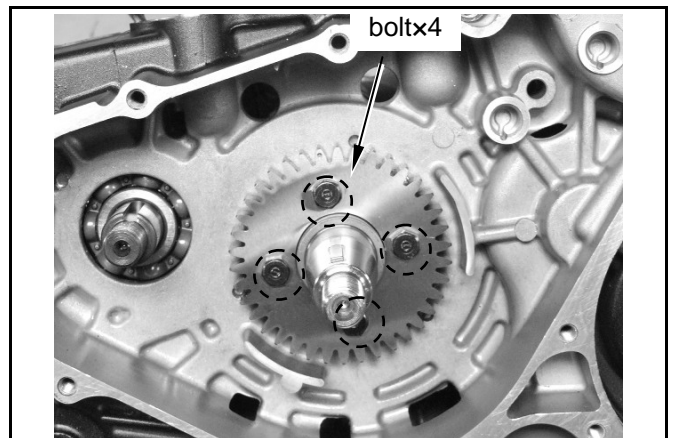

## 9. Crank / Crankcase / Shifting gear



Remove the 6mm bolt from left crankcase.  
(boltX11)

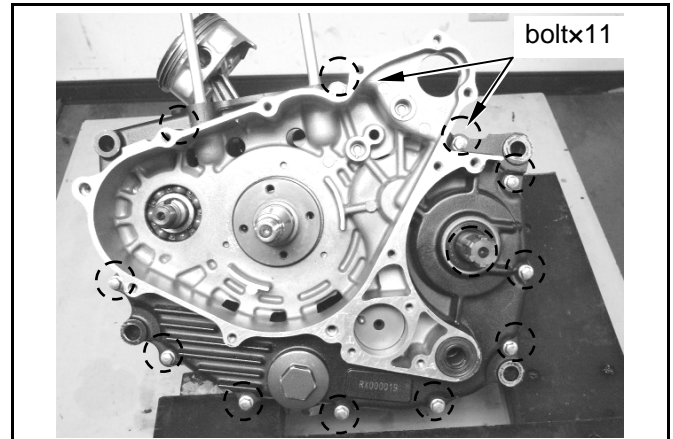

Remove the left crankcase from the right crankcase.  
Remove balancing shaft.

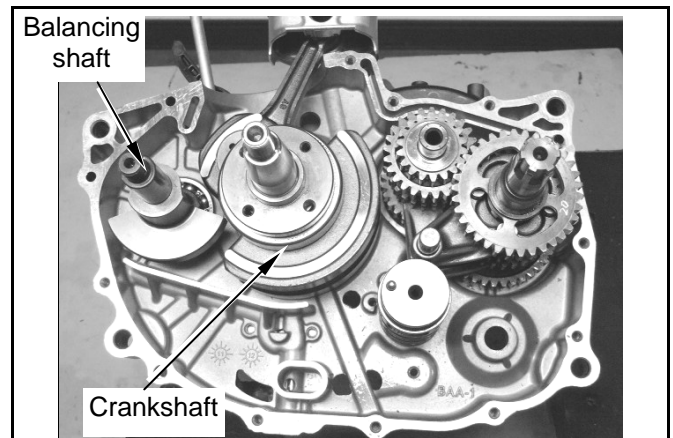

Shake the crankshaft gently and pull out the crankshaft.

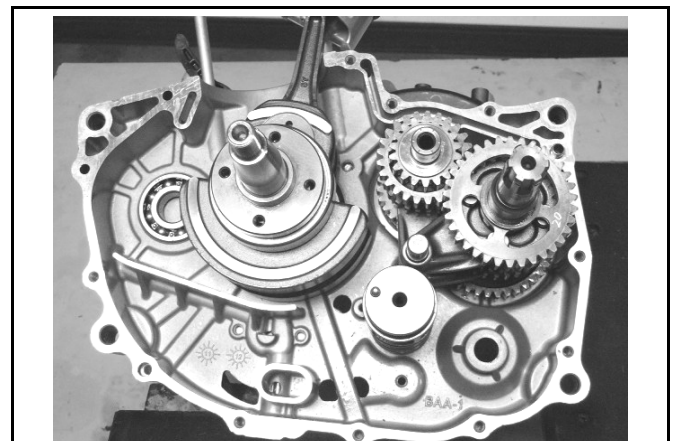

### Crankshaft inspection

Use a feeler gauge to measure left and right clearance of conrod big end.

**Service limit: replace if over 0.6mm**

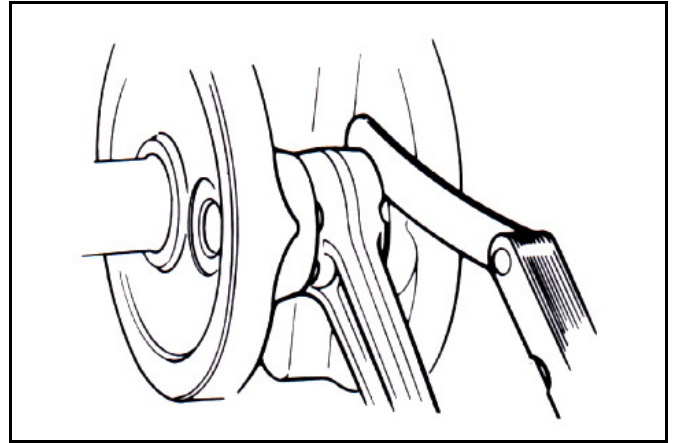

Place the crankshaft on a V-block, measure the clearance of the big end at the vertical direction.

**Service limit: 0.05 mm**

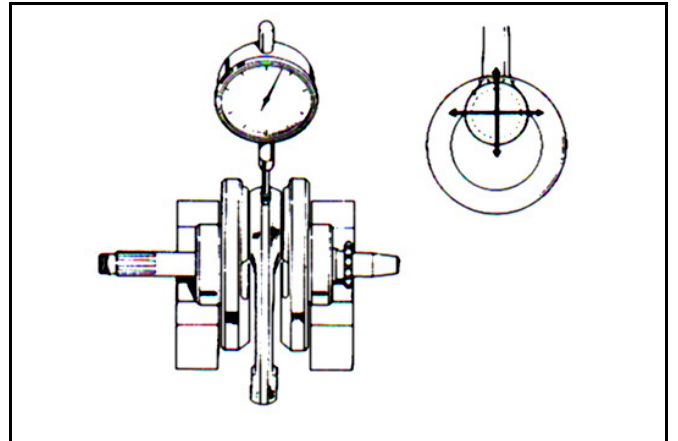

Place the crankshaft on a V-block, measure the crankshaft run-out.

**Service limit: 0.10 mm**

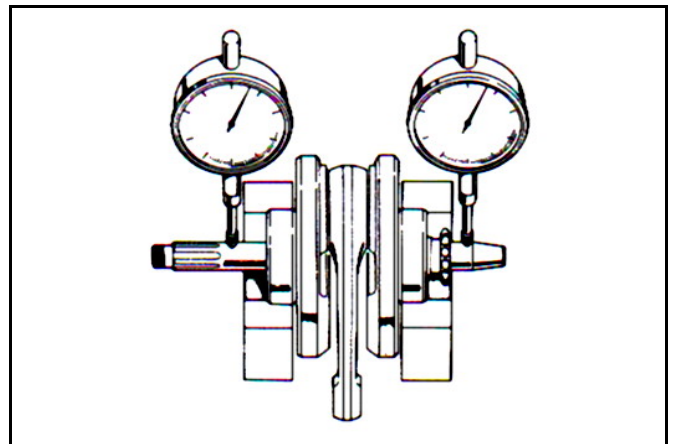

### Crankshaft bearing inspection

Rotate the bearings to check if the bearings rotate smoothly and silently.

Check if the inner ring of the bearing fixes firmly on the crankshaft.

Replace the bearing if there is excessive noise or roughness.

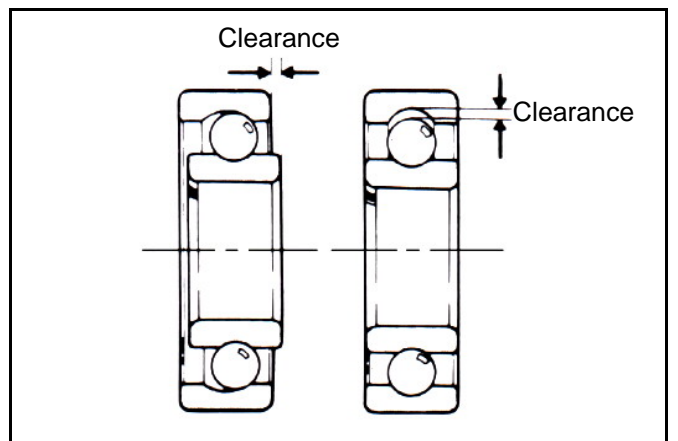

### Transmission disassembly

Remove the gear shift fork shaft.

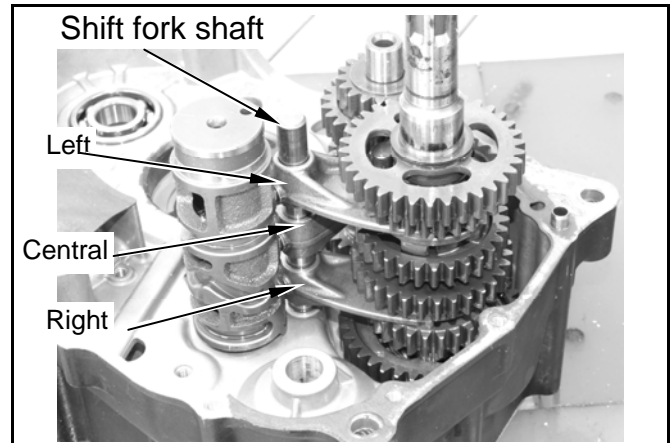

Remove shift drum, then remove left, central, and right shift fork.

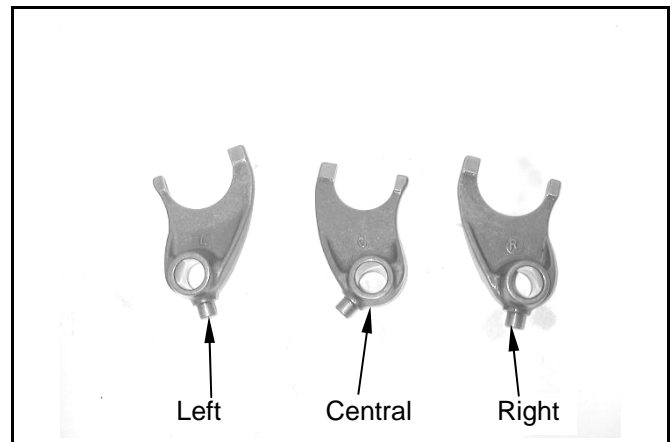

Remove the transmission mechanism.

Disassemble the gears and washers on the main shaft and counter shaft, and arrange them in order.

Check if the teeth and grooves of each gear worn and damaged.

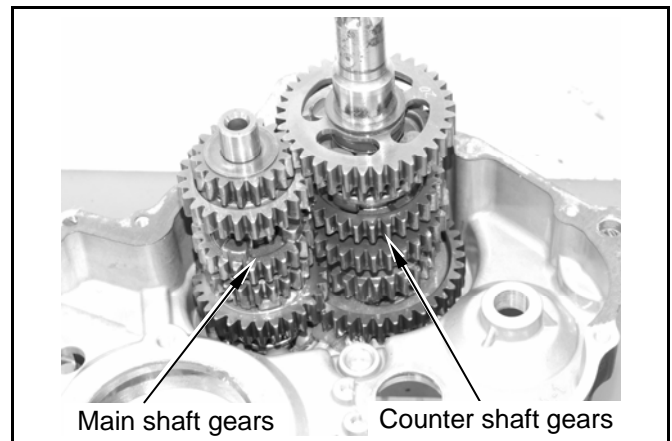

Assemble the gears and washers onto the main shaft and counter shaft in order after the inspection.

#### Caution

- Apply clean engine oil to the gears before assembly.
- Make sure circlips are securely seated in the shaft grooves.

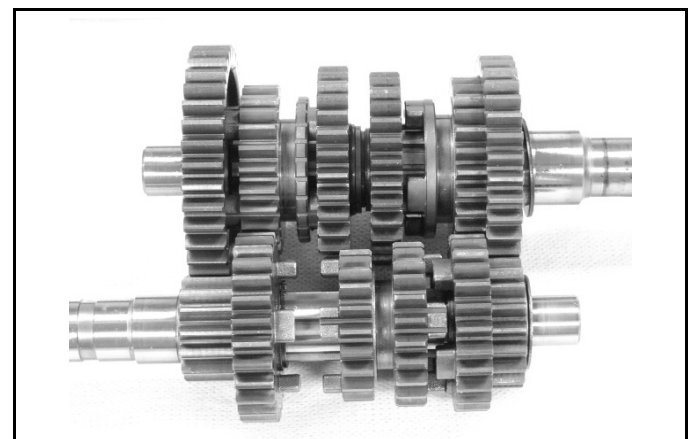

### Transmission inspection

Check if the gear shift fork worn, bent or damaged.

Measure the inner diameter of the gear shift fork.

**Service limit: 12.05mm**

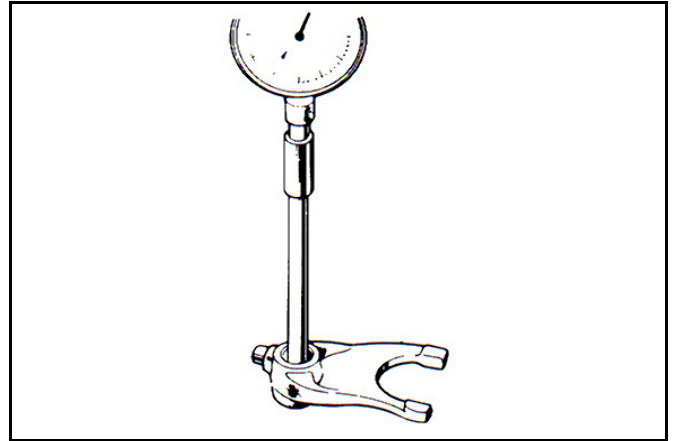

Measure the thickness of the gear shift fork claws.

**Service limit: 4.7mm**

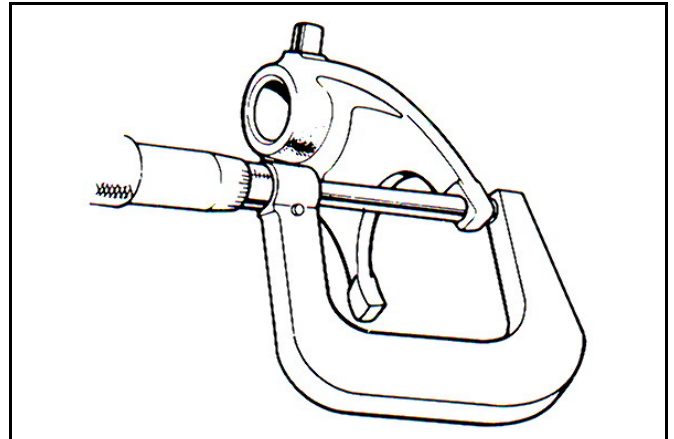

Measure the outer diameter of the gear shift fork shaft.

**Service limit: 11.96mm**

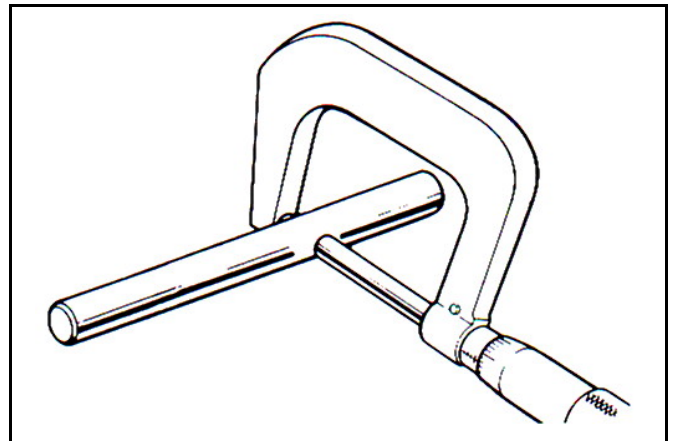

Check if the gear shift drum worn or damaged.



### Crankcase inspection

Check if the oil path on the crankcase clogged, blow the oil path with compressed air if necessary.

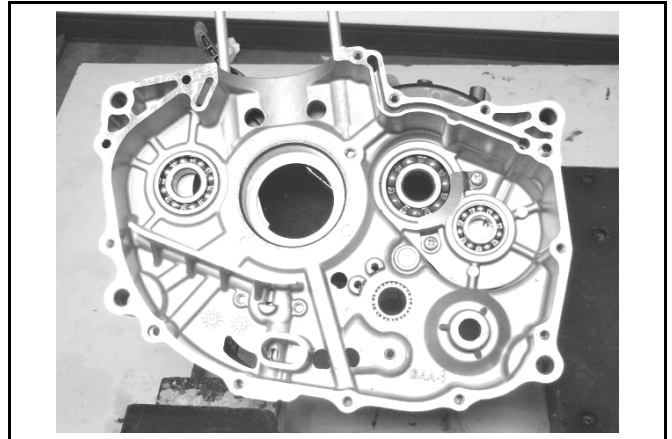

### Crankcase bearing / oil seal inspection

Rotate the bearings to check if the bearings rotate smoothly and silently. Check if the outer ring of the bearing fixes firmly on the crankcase. Replace the bearing if there is excessive noise, roughness, or looseness. Check if counter shaft oil seal damaged, replace if necessary.

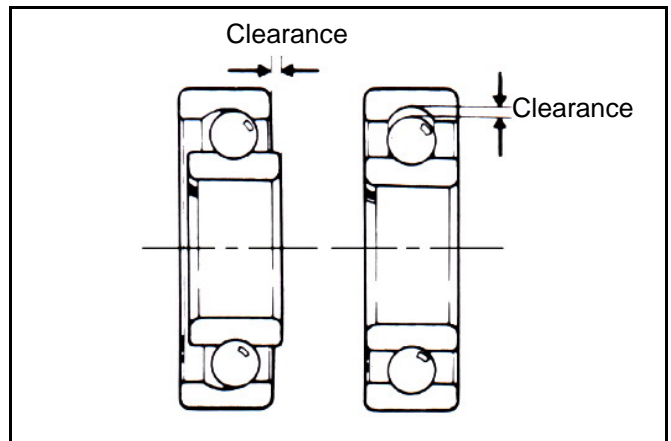

### Crankcase bearing removal

Remove the damaged bearing by using the inner bearing puller.

**Special tool:**

**Inner bearing puller SYM-6204025**

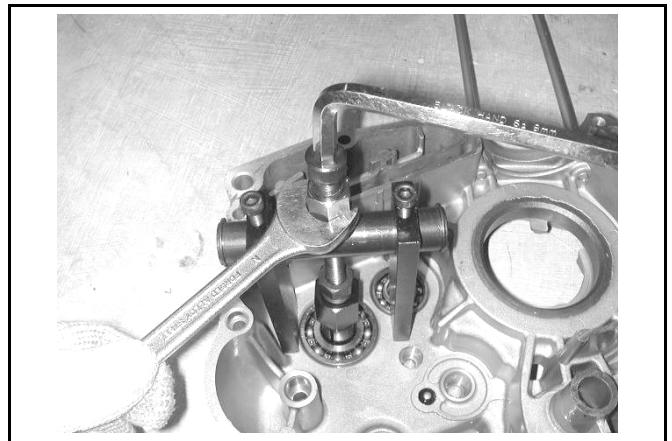

### Crankcase bearing installation

Install new bearings onto the crankcase by using bearing driver.

**Special tools:**

**Bearing driver 6204 SYM-6204024**

**Bearing driver 6304 SYM-6204024**

**Bearing driver 6203/6305 SYM-6204024**

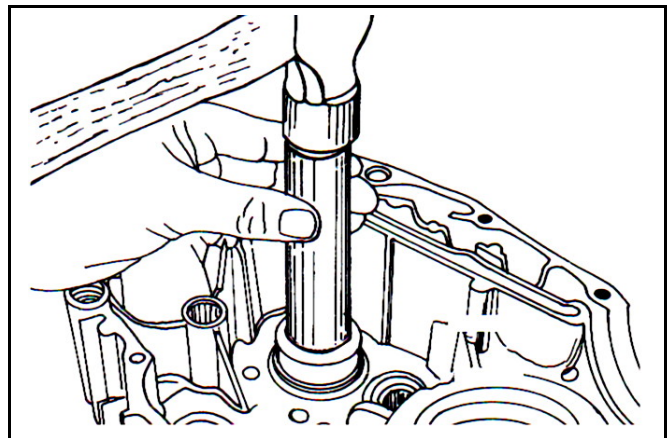

### Crankcase assembly

Remove the crankcase gasket and dowel pins.  
Clean the gasket residues off the crankcase contact surface.

**⚠ Caution**

- Do not damage the contact surface of the crankcase.
- Use solvent to wet the gasket material in order to remove it more easily.

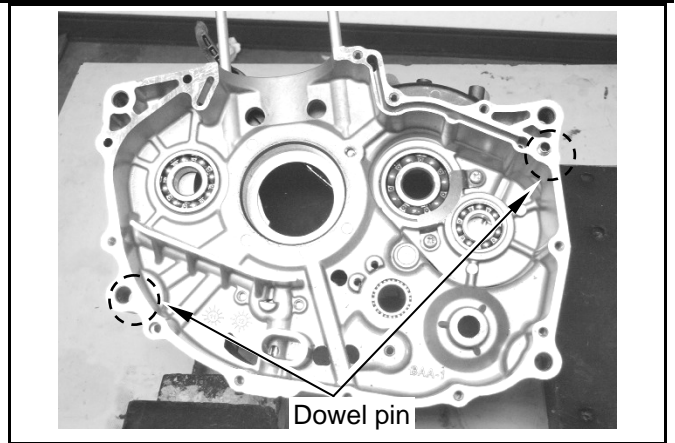

Install main shaft and counter shaft to the right crankcase.

**⚠ Caution**

- Make sure the right washer in the position.

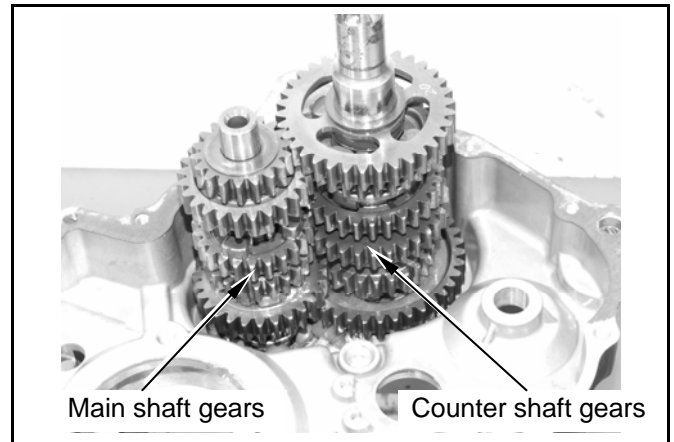

Install the gear shift drum.

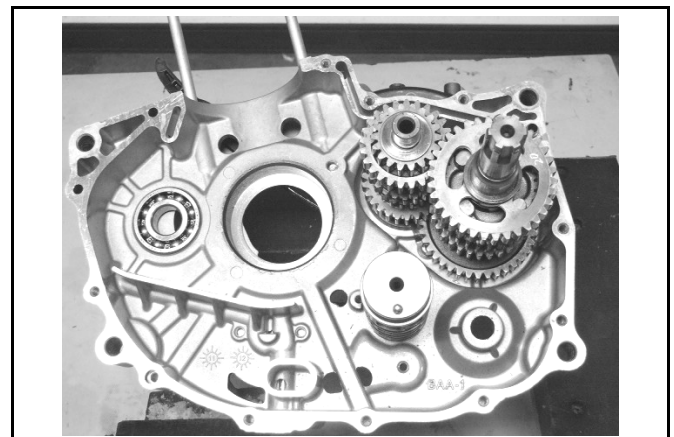

**⚠ Caution**

- When installing shift forks, make sure the letters facing upward.

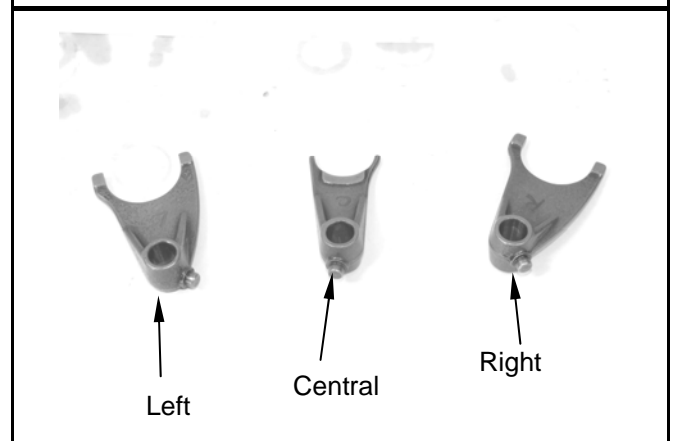

## 9. Crank / Crankcase / Shifting gear



Install shift forks (left, right) on counter shaft, and install the shift fork pin into shifting drum groove. Install shift fork (center) on main shaft, and install the shift fork pin into shifting drum groove. Align the holes of shift forks, then insert gear fork guide shaft.

### Caution

- Make sure all parts move smoothly; rotate the gear shift drum to neutral gear. (rotate the main shaft, and the counter shaft will not rotate simultaneously)

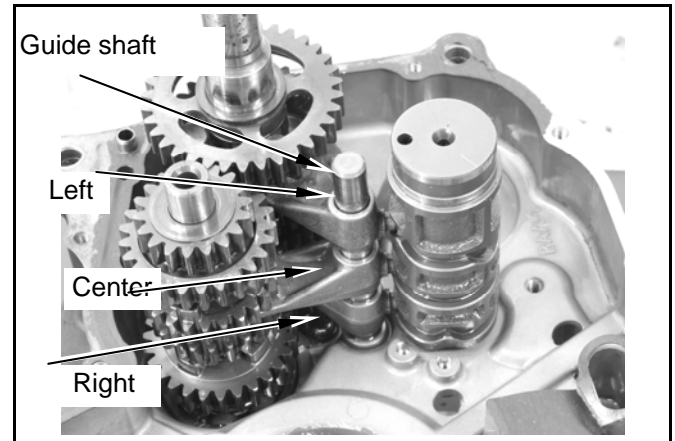

Install crankshaft and balancing shaft to the right crankcase.

Install the new crankcase gasket and dowel pins.

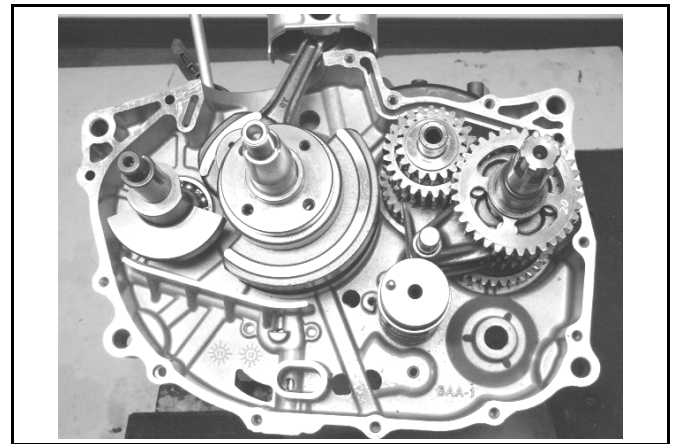

Install left crankcase.

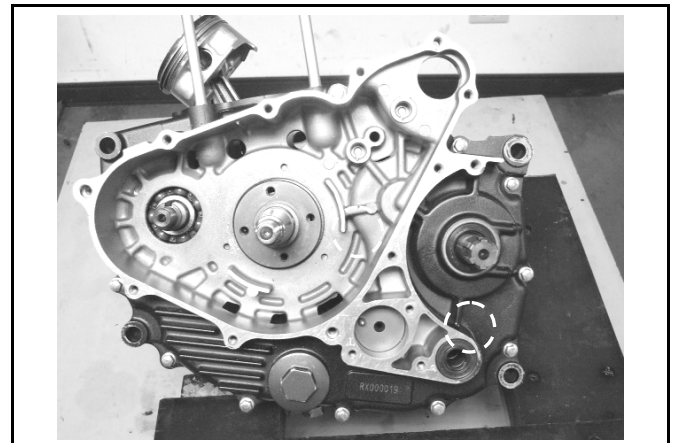

Tighten crankcase left side screws.

**Torque value: 0.8~1.2kgf-m**

Coat grease to the new counter shaft oil seal and install it to crankcase.

Tighten crankcase right side bolts.

**Torque value: 0.8~1.2kgf-m**

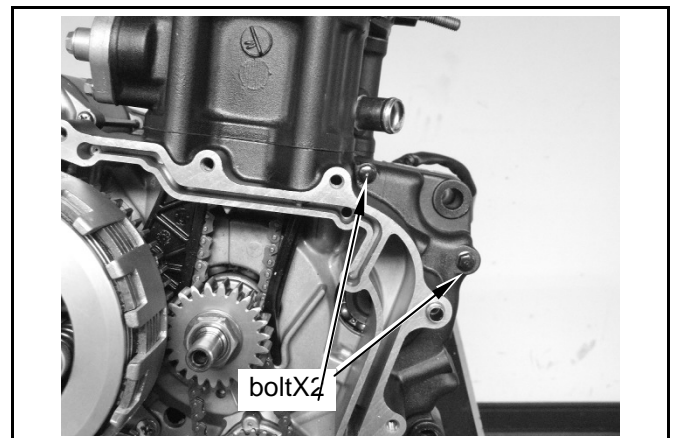



Install balancing shaft drive gear, and align woodruff key and the mark on the gear.  
Tighten balancing shaft drive gear bolts.  
**Torque value: 0.8~1.2kgf-m**

### Caution

- Make sure aligning woodruff key and the mark on the gear; incorrect installation will result in knocking of crankshaft and balancing shaft and cause serious damage.

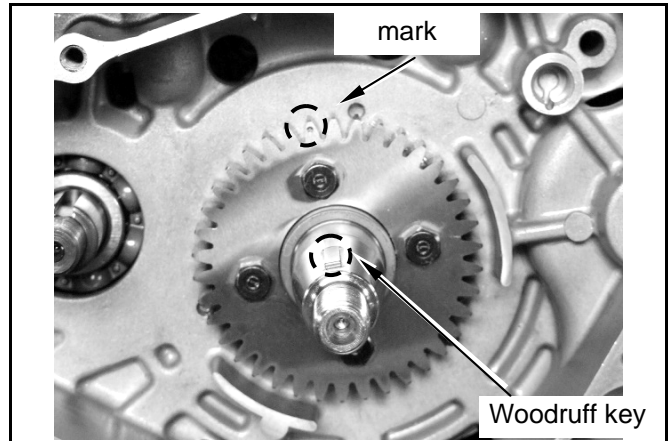

Install balancing shaft gear, align marks on balancing shaft gear and balancing shaft drive gear.  
**Torque value:0.8~1.2kgf-m**

### Caution

- Make sure aligning marks on balancing shaft gear and balancing shaft drive gear; incorrect installation will result in knocking of crankshaft and balancing shaft and cause serious damage.

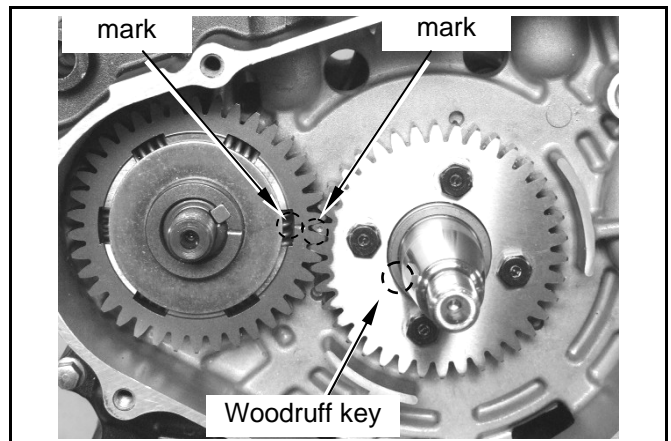

Install the fix circlip on the balancing shaft gear.  
Tighten balancing shaft lock nut.  
**Torque value: 8.5~10.5kgf-m**

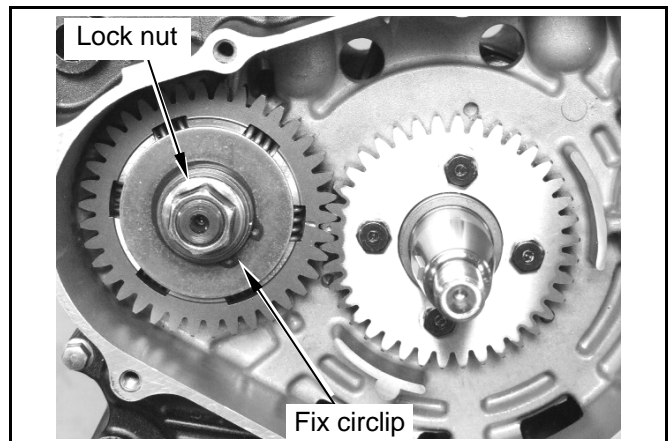

Install cam chain.  
Install the cam chain tensioner arm. (boltx1)。

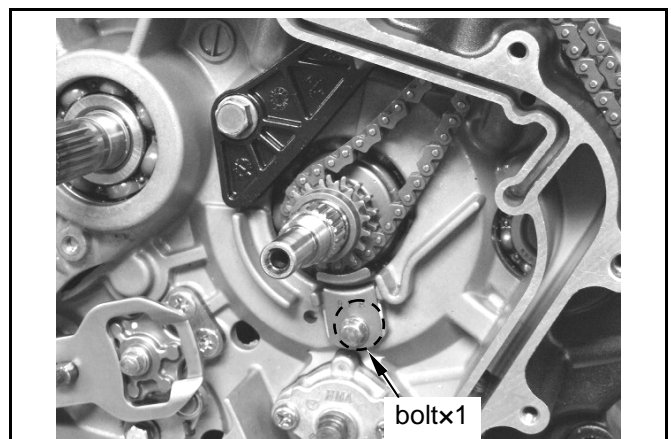

**NOTE:**

Mechanism Diagram ..... 10-1	Coolant Change ..... 10-5
Precautions in Operation ..... 10-2	Radiator ..... 10-6
Troubleshooting ..... 10-2	Water Pump ..... 10-8
Diagnosis of Cooling System ..... 10-3	Thermostat ..... 10-12

## Mechanism diagram

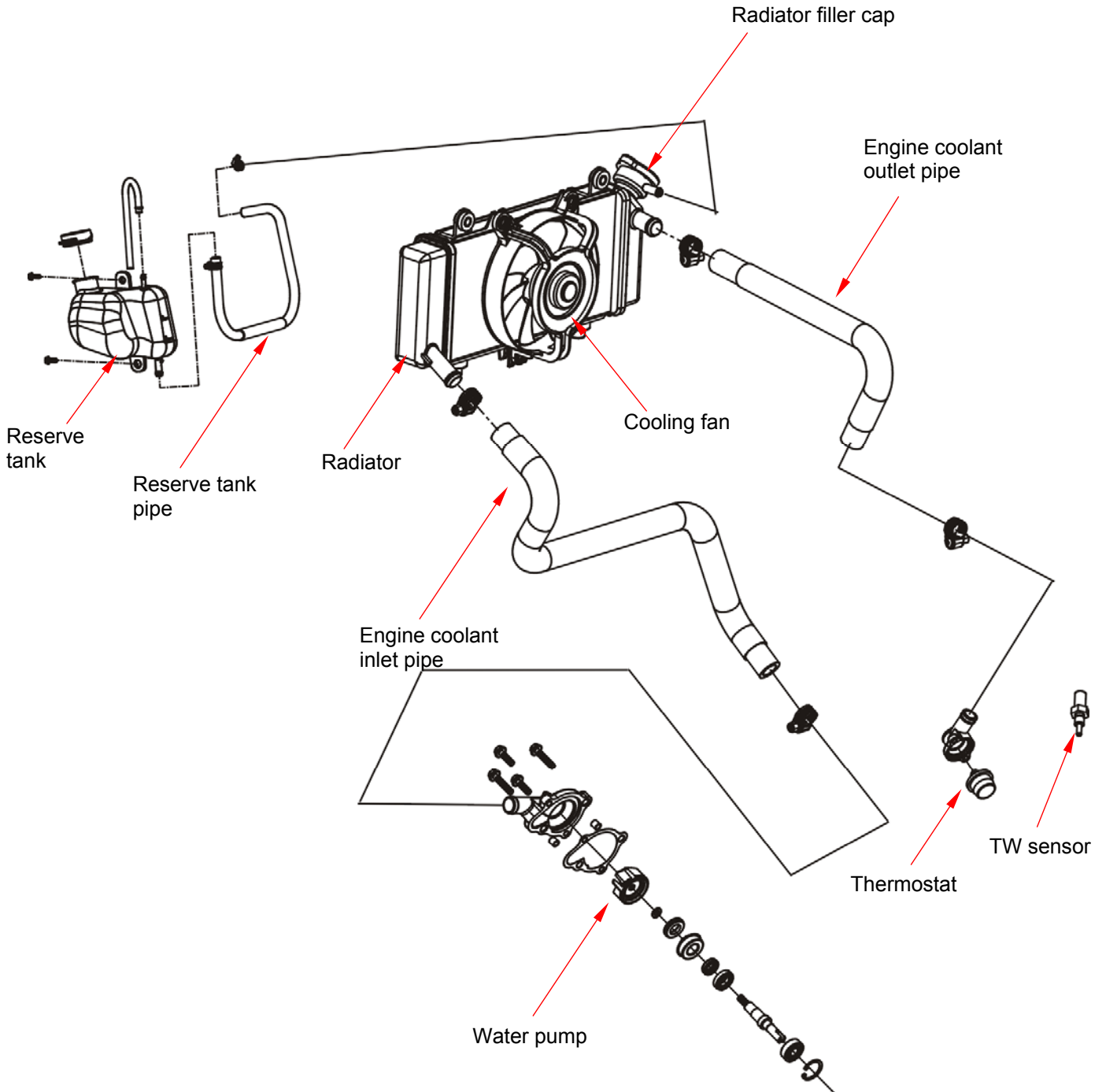

## Precautions in operation

### General information

#### Caution

- While the engine is running, never attempt to open the radiator filler cap, the pressurized hot coolant may shoot out and cause serious scalding injury. No maintenance work is allowed to perform unless the engine is completely cooled down.
- Refill the radiator with distilled water or specified additives.
- Add coolant to the reservoir.
- The cooling system can be serviced on the motorcycle.
- Never spill the coolant to the painted surface.
- Test the cooling system for any leakage after the repair.
- Please refer to Ch3 for inspection of TW sensor.

### Specification

Item	Specification
Pressure to open filler cap	0.75~1.05 Kg/cm <sup>2</sup>
Capacity of coolant: Engine + radiator Reservoir	1200c.c. 400c.c.
Thermostat	Begins to activate at: 82~95°C Stroke : 0.05~3.00mm
Boiling point	Not-pressure :107.7°C Pressurized: 125.6°C

### Torque Value

Water pump rotor 1.0~1.4kgf-m

### Special tools

**Water pump bearing driver** (6901) SYM-9100100

**Water pump oil seal driver (Inner)** SYM-9120500-H9A

**Water pump mechanical seal driver** SYM-1721700-H9A

**Inner bearing puller** SYM-6204020

## Troubleshooting

### Engine temperature too high

- TW sensor malfunction.
- Thermostat seized.
- Insufficient coolant.
- Water hoses clogged.
- Water pump malfunction.
- Fan motor malfunction.
- The filler cap of the radiator malfunction.

### Engine temperature too low

- TW sensor malfunction.
- Thermostat seized.

### Coolant leakage

- water pump mechanical seal malfunction
- Thermostat O ring deterioration.
- Water hose deteriorated or damaged

## Diagnosis of cooling system

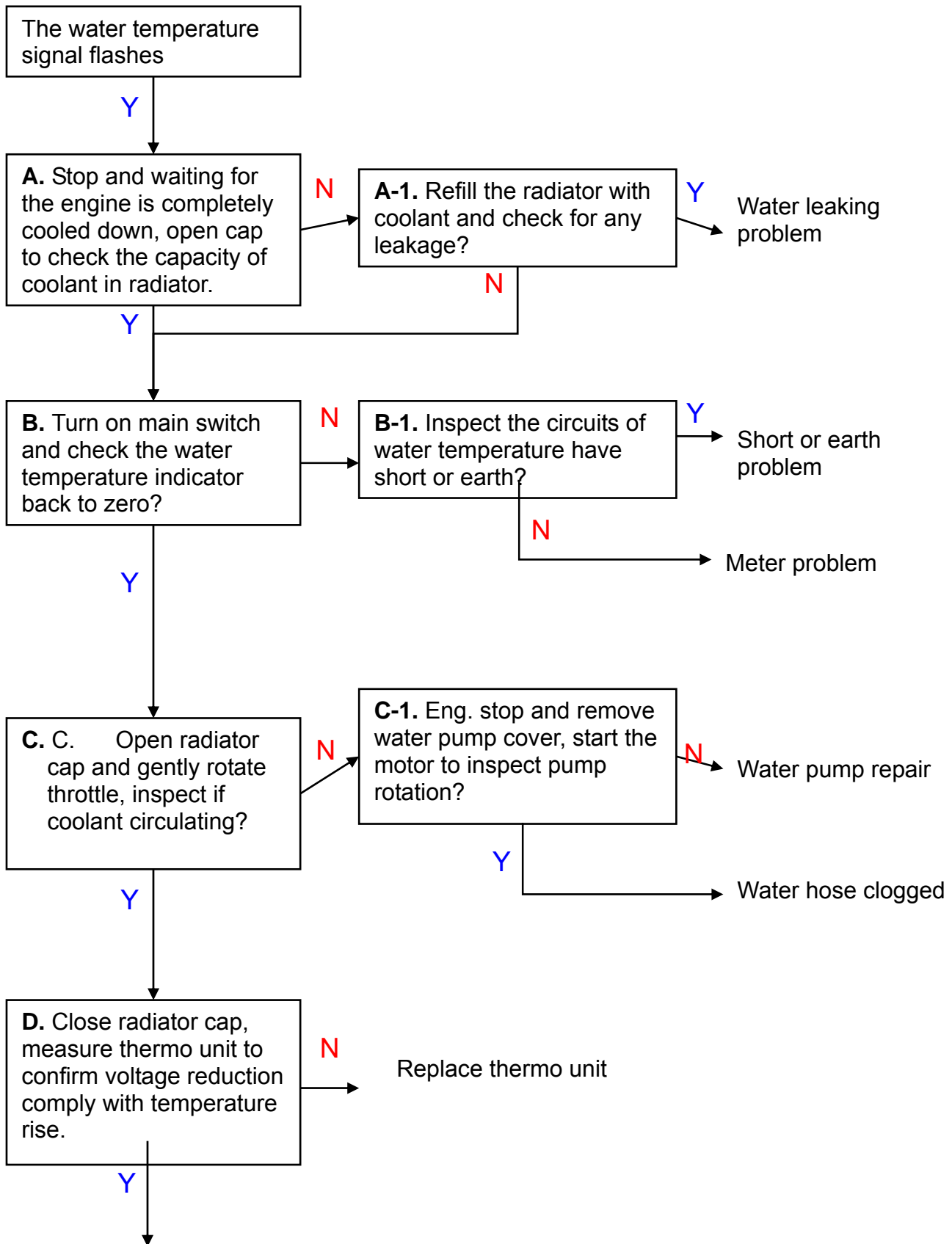

Next page

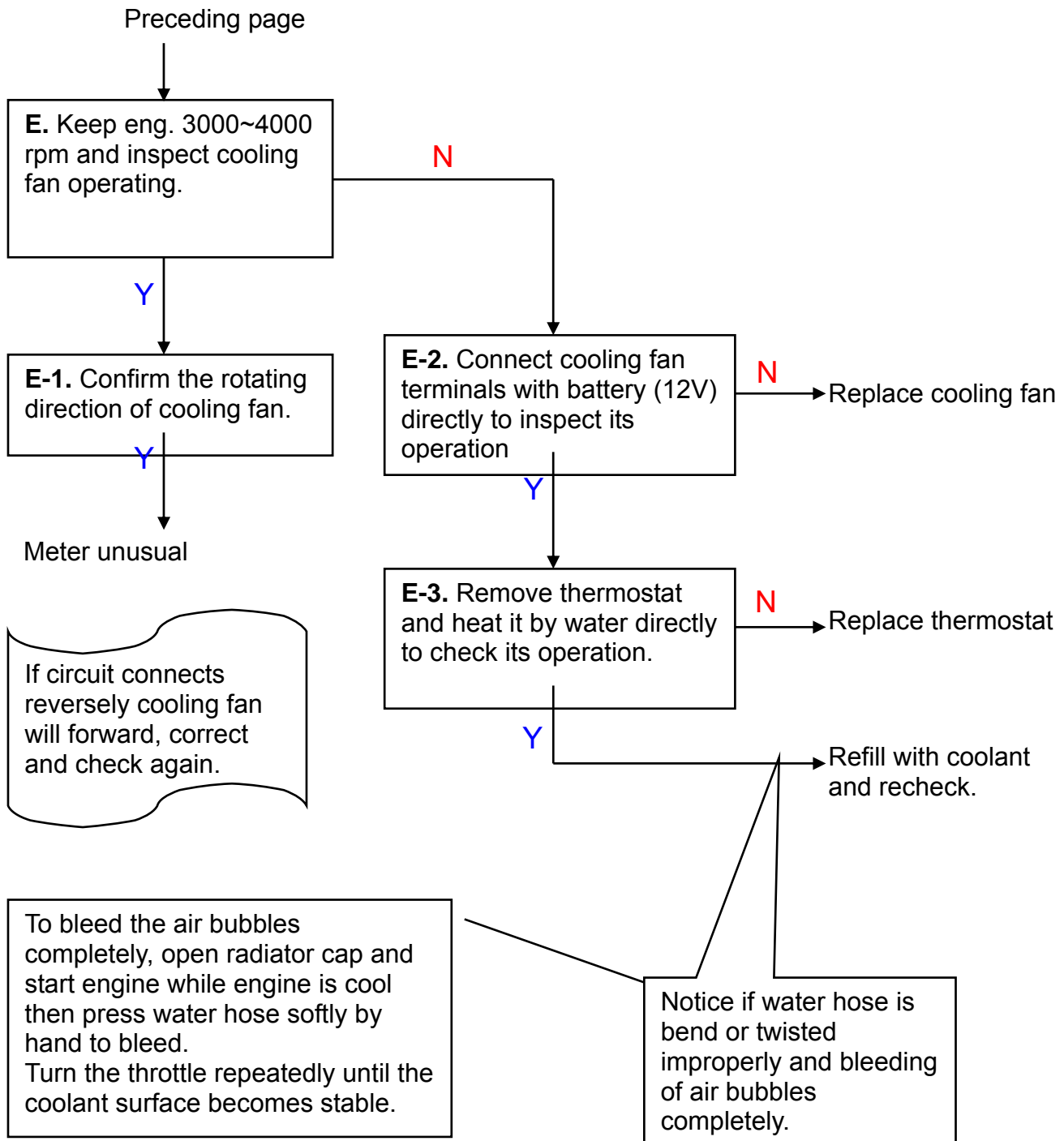

## Coolant change

### Warning

- Never attempt to carry out service work on the cooling system unless the engine is completely cooled down, otherwise, you may get scalded.

Remove right-front body cover. (screwX2)  
Remove radiator tank cap.

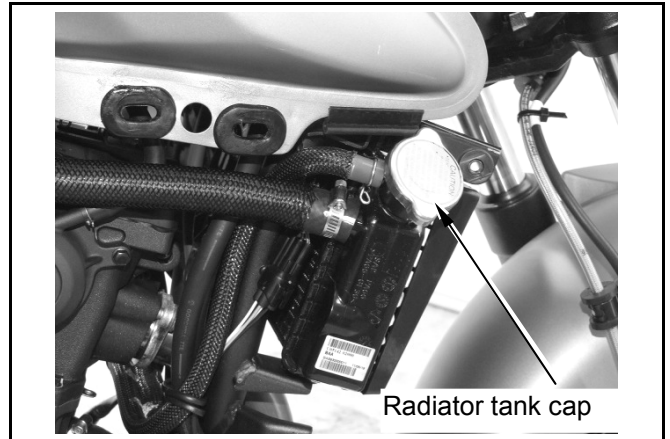

Remove under spoiler. (boltX4)  
Place a water pan under the water pump;  
loosen the drain bolt to drain out the coolant.  
Reinstall the drain bolt.

Refill system with coolant and bleed the air bubbles.

- Remove radiator tank cap.
- Start the engine and confirm no bubbles from the radiator and the coolant level is stable.
- Shut down engine, refill coolant if necessary.

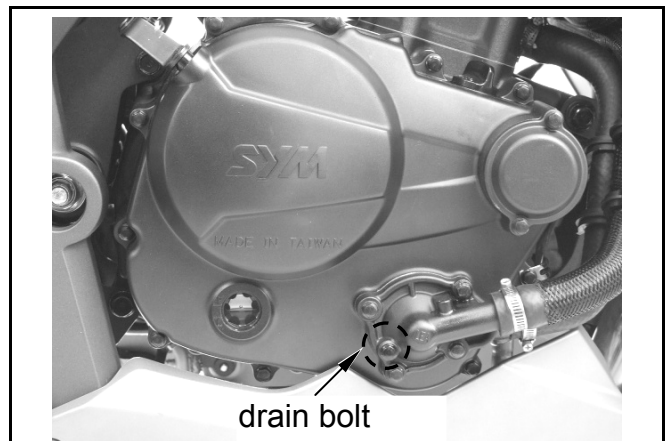

### Caution

- To avoid the water tank rusting, please do not use an unknown trademark refrigerant.

Coolant recommended: SYM Bramax radiator agent.

Concentration: 50%

## Reserve tank check

- Remove left-front body cover.
- Check reserve tank coolant level, refill coolant to standard level. (between upper and lower)
- Install reserve tank cap.

### Caution

- Do not fill too much coolant, or the coolant will backflow after the water temperature rises.



### Radiator

#### Removal / Check

Remove radiator air duct. (boltX3)  
Check for any leakage from weld seam.  
Blow radiator with compressed air. If the radiator is blocked by dirt, use low pressure water jet to clean it.  
Care shall be taken when straightening the sink fan.

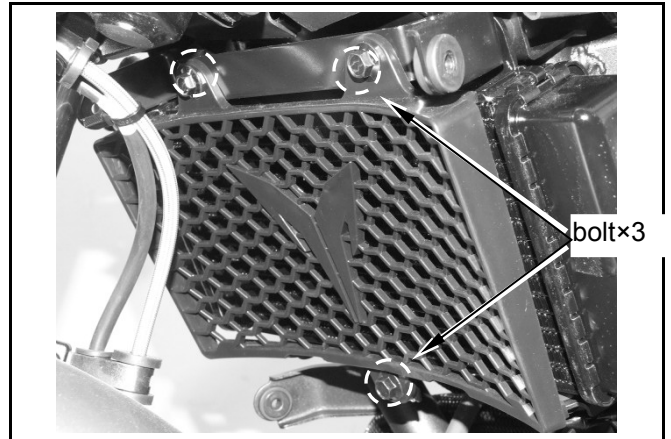

Place a water pan under the water pump;  
loosen the drain bolt to drain out the coolant.  
Install drain bolt.

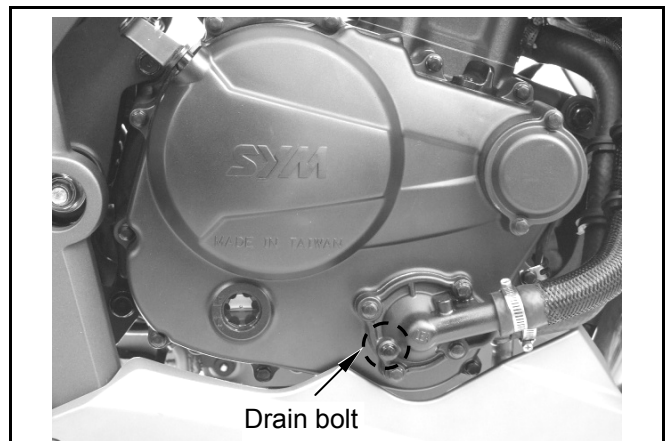

Remove radiator bolt. (boltx2)

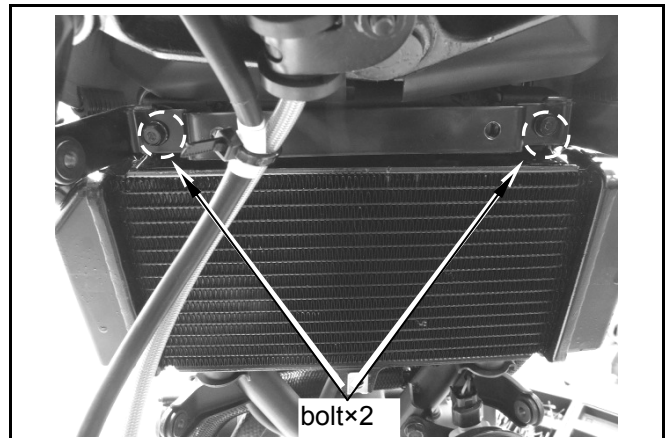



Disconnect the fan motor coupler.  
Remove engine coolant inlet pipe, reserve tank inlet pipe and radiator inlet pipe.  
Remove the radiator and the cooling fan.

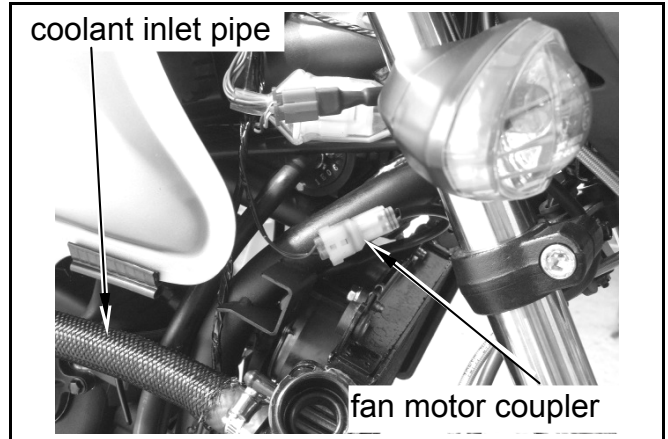

### Disassembly

Remove the cooling fan mounting bolt and the fan. (bolt×3)  
Remove thermo switch.

### Assembly

Install cooling fan onto the radiator. (bolt×3)  
Install thermo switch.

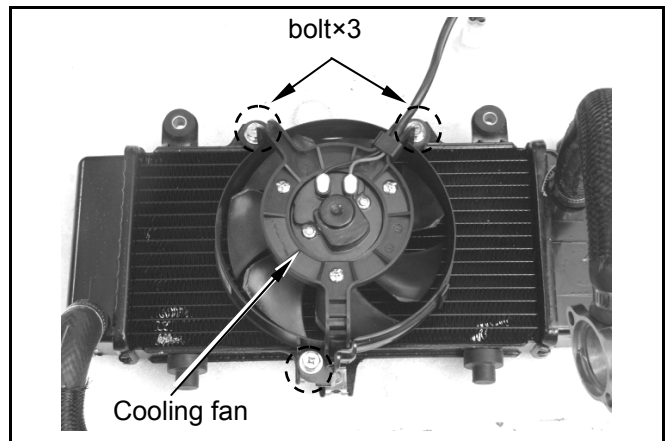

### Installation

Install the removed parts in the reverse order of removal.  
Upon completion, check for any leakage.

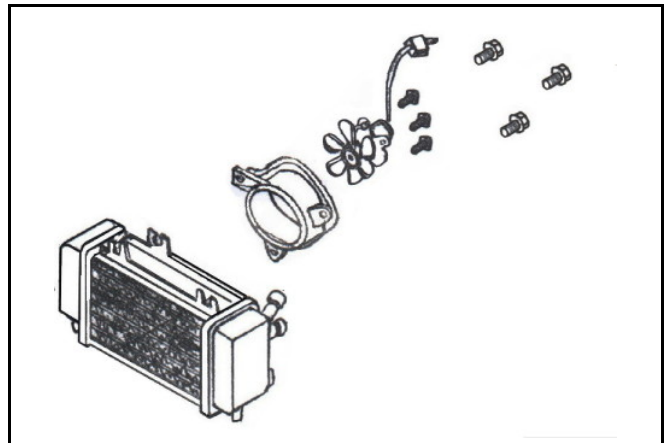

## Water pump

### Water pump seal / cooling system leakage inspection

- Remove drain bolt to drain some coolant to check if there is greasiness in it.
- Remove engine oil gauge rule to check if the oil is emulsified.

If the two phenomena appear, oil seals of water pump, cooling system, cylinder head, or cylinder gasket could be damaged. Please remove right crankcase to check (replace) water pump oil seals, then inspect cylinder head and cooling system.

### Water pump removal

Remove drain bolt and drain out coolant.

Remove the water hose.

Remove four water pump bolts and cover.

Remove gasket and dowel pin.

Remove 12 right crankcase bolts and the crankcase.

Remove gasket and dowel pin.

Hold water pump drive shaft and remove water pump rotor clockwise.

### Caution

- The rotor is provided with left turn thread.

Remove circlip from right crankcase.

Remove water pump shaft and inner bearing. Remove the outside bearing by inner bearing puller.

Rotate the inner ring of bearing, the bearing shall move smoothly and quietly.

If the bearing does not rotate smoothly or produces a noise, replace it with new one.

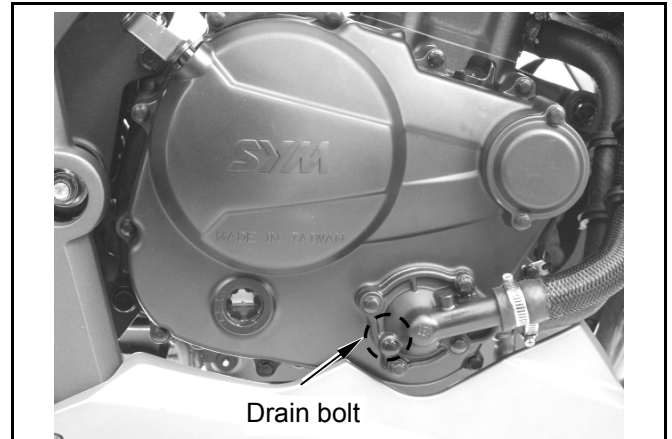

Drain bolt

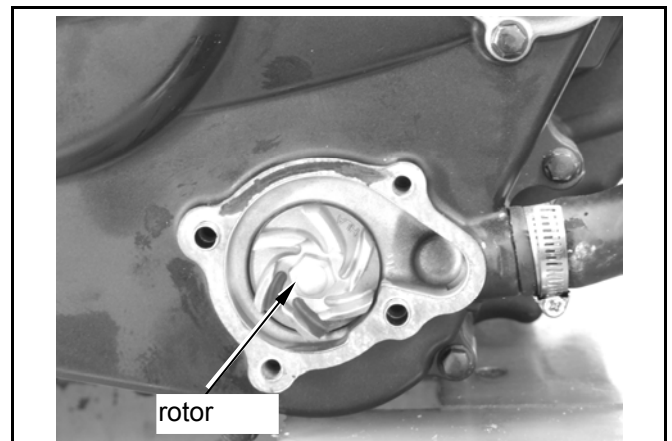

rotor

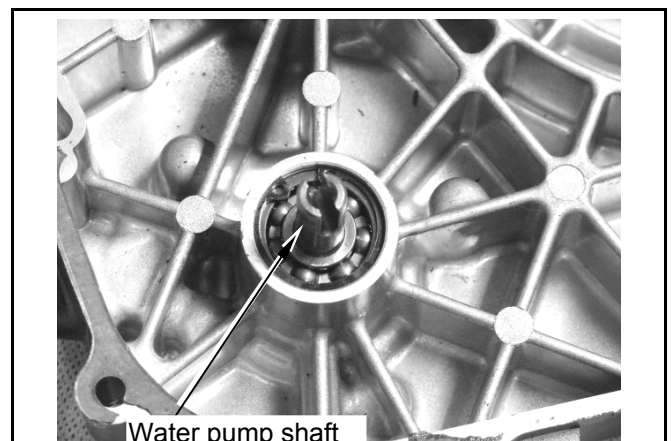
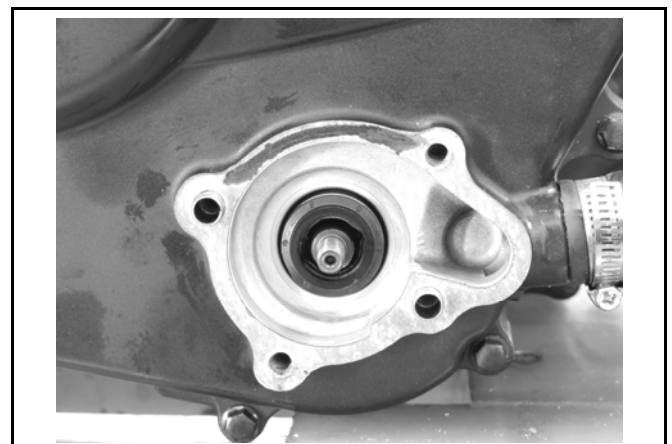

Water pump shaft

Check if mechanical seal and inside seal damaged or worn.

**⚠ Caution**

- The mechanical seal and inside seal must be replaced as a unit.

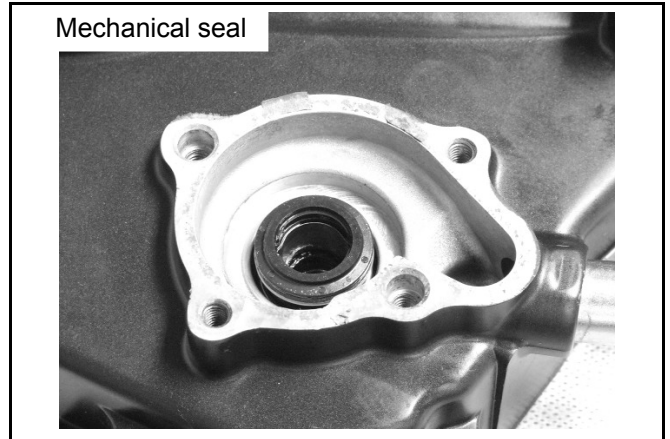

**Replacement of Mechanical Seal**

Remove the inside bearing from inner side of right crankcase by inner bearing puller. Drive the seal by bearing driver.

**Special tool**

**Bearing driver(6901) SYM-9100100**

**⚠ Caution**

- Replace with a new mechanical seal after removing it.

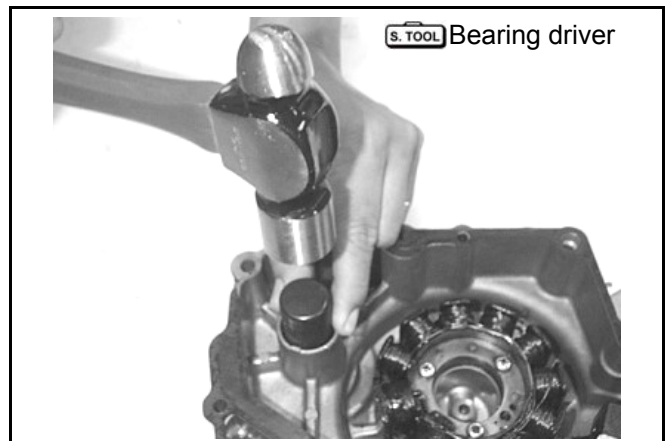

Apply sealant to the mating surfaces of the right crankcase before installing the new mechanical seal.

Install the new mechanical seal onto the right crankcase.

**Special tool**

**Water pump mechanical seal driver SYM-1721700-H9A**

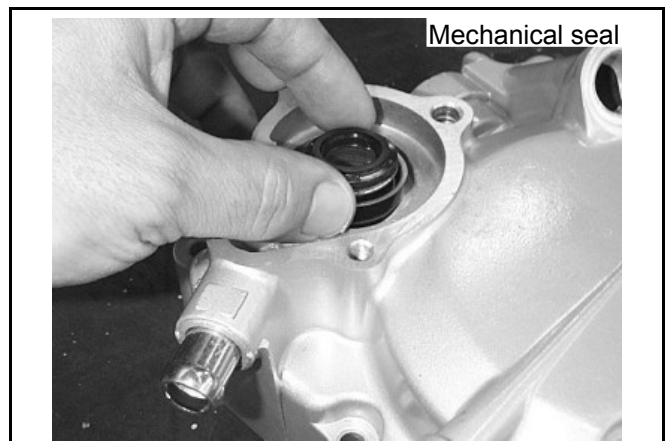

## 10. Cooling System

Install the new inner seal (12×20×5) onto the right crankcase.

**Special tool**

**Water pump oil seal driver (inner)**  
**SYM-9120500-H9A**

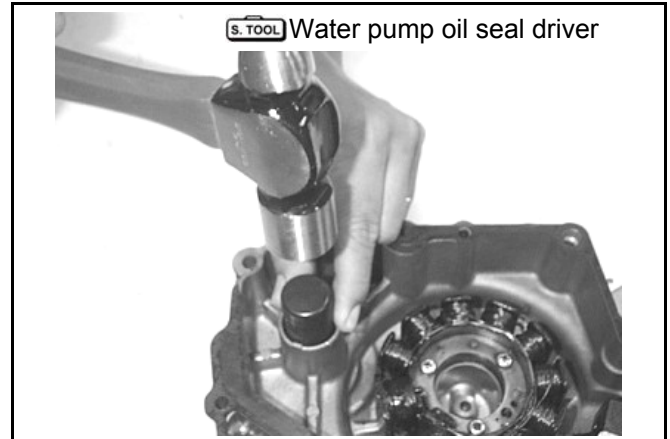

Install a new outside bearing to the right crankcase cover.

**Special tool**

**Bearing driver (6901)SYM-9100100**

**⚠ Caution**

- Do not reuse old bearing. It must be replaced with a new one once it has been removed.

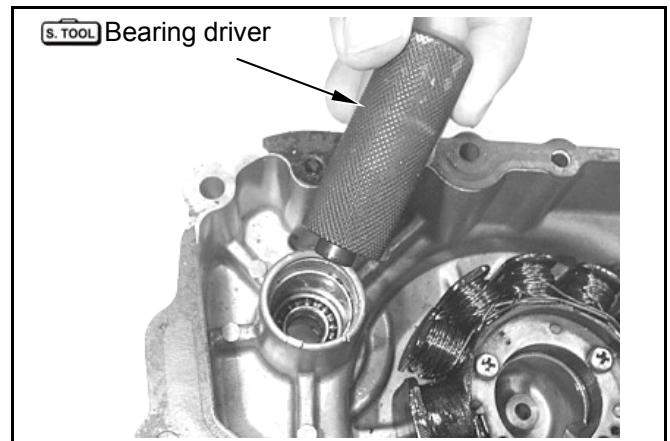

Mount the water pump shaft and the inner bearing to the right crankcase cover.

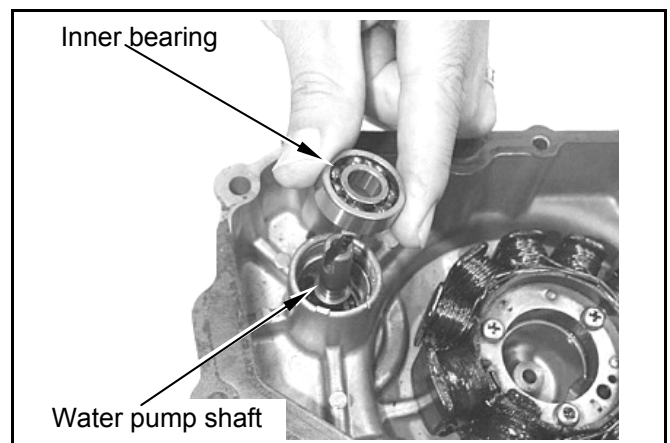

Install the inner bearing circlip.

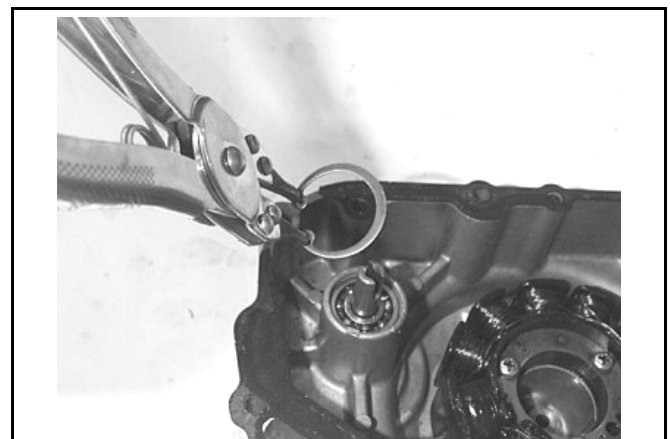

## Rotor installation

Install the seal washer onto the water pump shaft.

### Caution

- Washer must be replaced together with the mechanical seal.



Install the rotor onto the water pump shaft.  
**Torque Value: 1.0~1.4kgf-m**

### Caution

- The rotor is left thread.

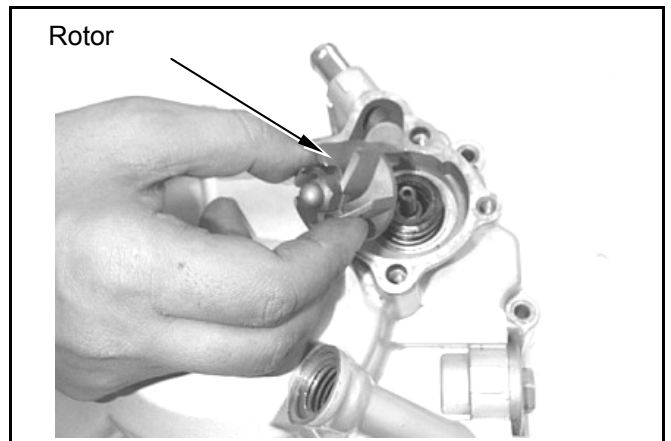

Install the dowel pin and right cover gasket.  
 Rotate the rotor to align it with water pump drive shaft. Install right crankcase. (bolt×10)

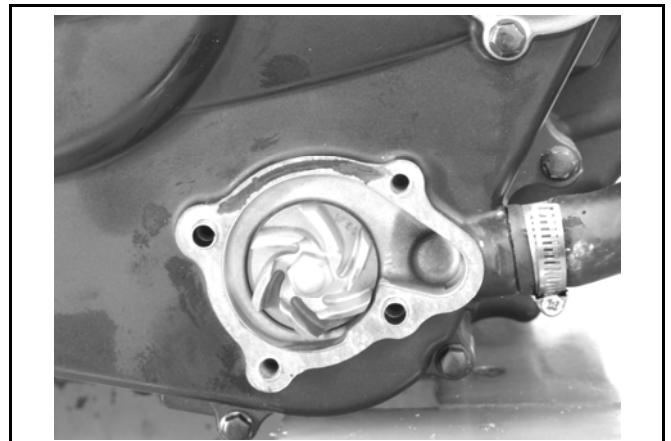

Install the dowel pin and new gasket.  
 Install the water pump cover. (bolt×4)



## Thermostat

### Removal

Remove thermostat cover. (boltX2)

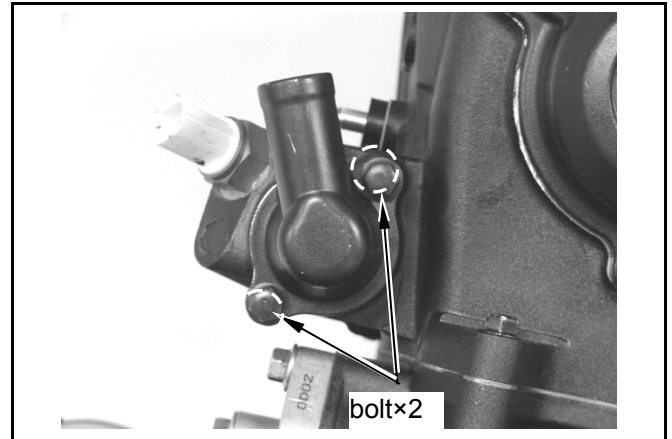

Remove thermostat

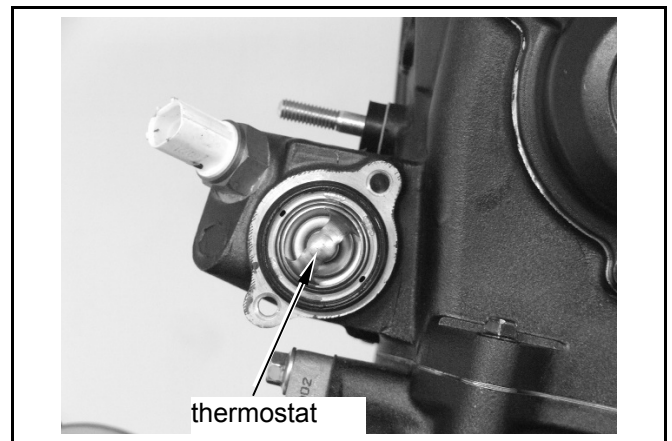

### Inspection

Check if thermostat damaged.



Place the thermostat into heated water to check its operation.

### Caution

- If the thermostat or thermometer contact with the container, the value displayed will be incorrect. If the valve of the thermostat remains open at room temperature or the valve operation is not corresponding to the temperature change, then it must be replaced.

### Technical Data

Valve begins to open	82~95°C
Valve stroke	0.05~3.00mm

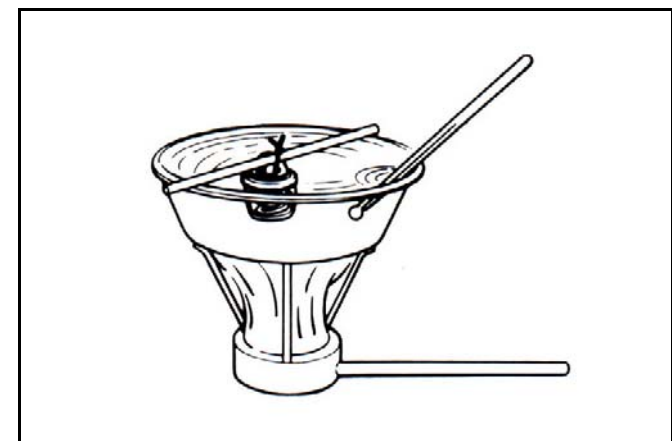

**Installation**

Install the thermostat.

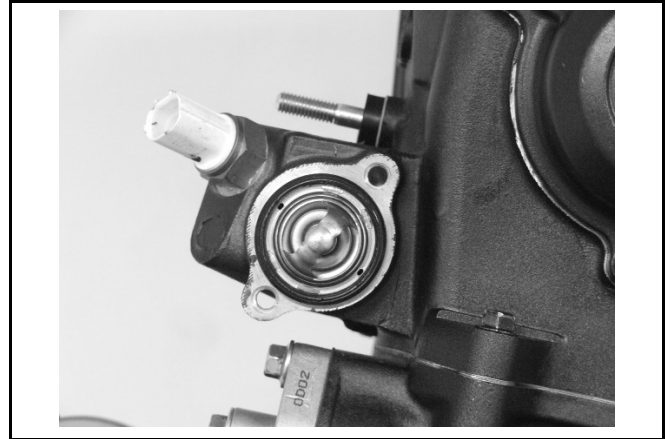

Install the thermostat cover. (bolt×2)  
Install hose, refill coolant and bleed out air bubble.

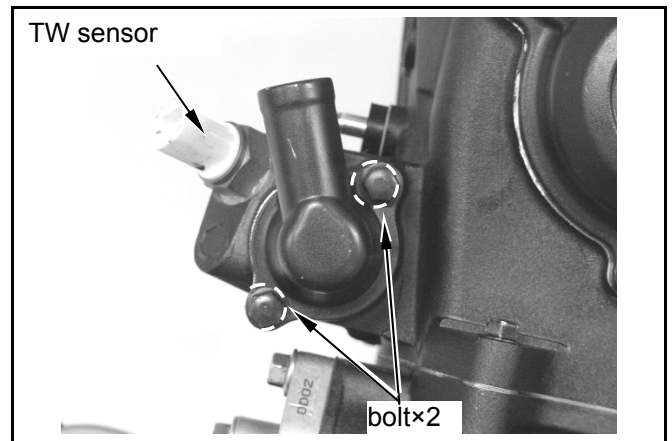

---

**NOTE:**



<b>Mechanism Diagram - Front Disk Brake</b> .....11-1	<b>Brake Fluid Replacement / Air Bleed</b> .....11-6
<b>Mechanism Diagram - Rear Disk Brake</b> .....11-2	<b>Front Brake Caliper</b> .....11-7
<b>Precautions in Operation</b> .....11-3	<b>Rear Brake Caliper</b> .....11-8
<b>Troubleshooting</b> .....11-4	<b>Brake Disk</b> .....11-9
<b>Disk Brake System Inspection</b> .....11-5	<b>Brake Master Cylinder</b> .....11-10

## Mechanism diagram – front disk brake

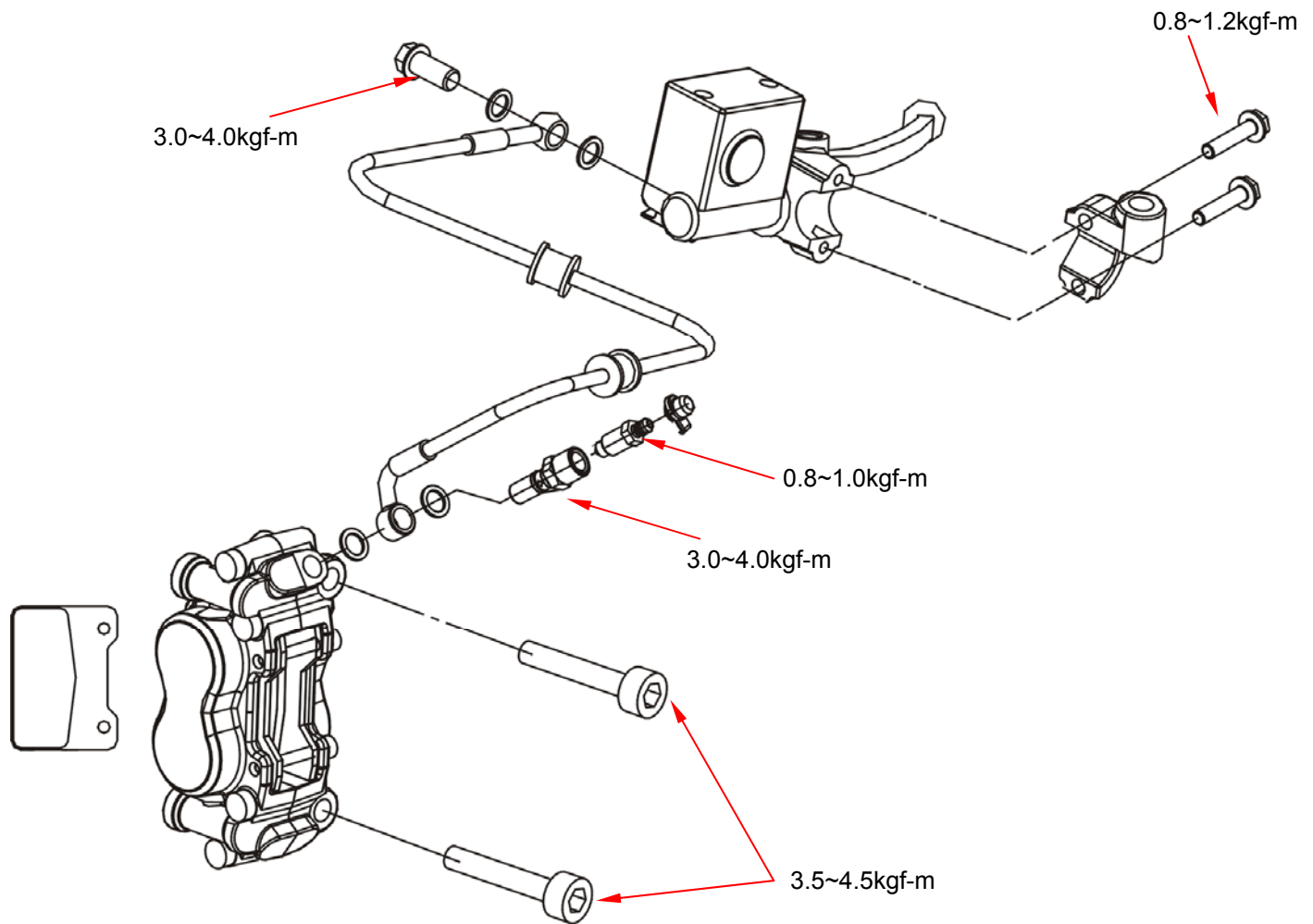

## Mechanism diagram – rear disk brake

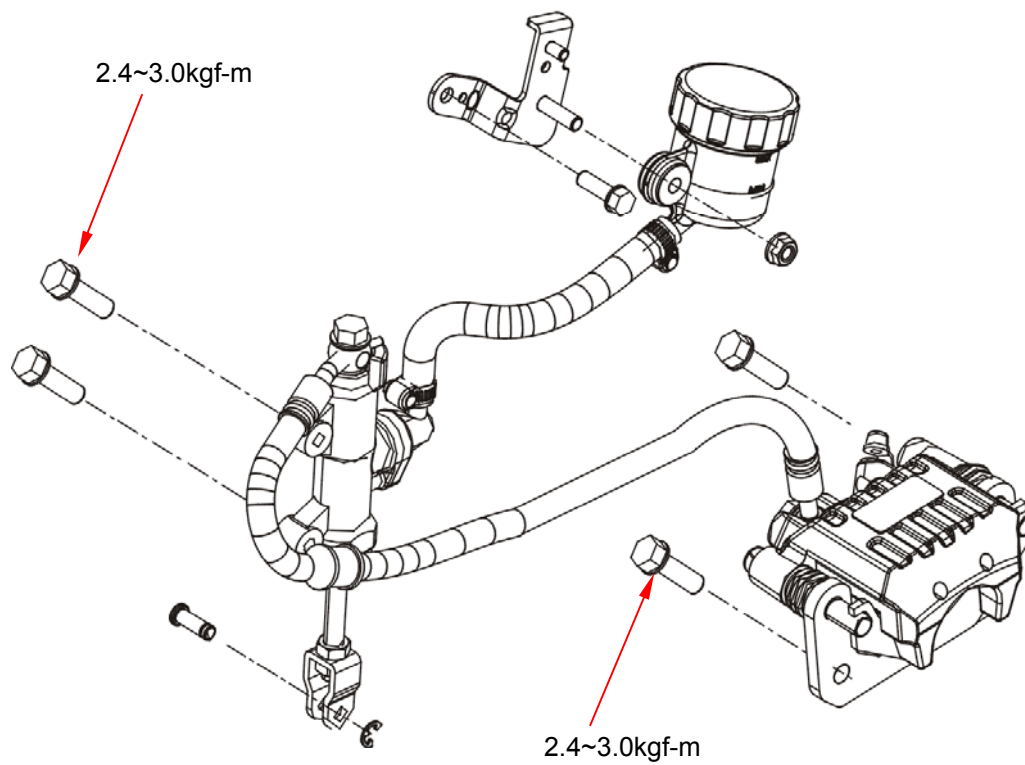
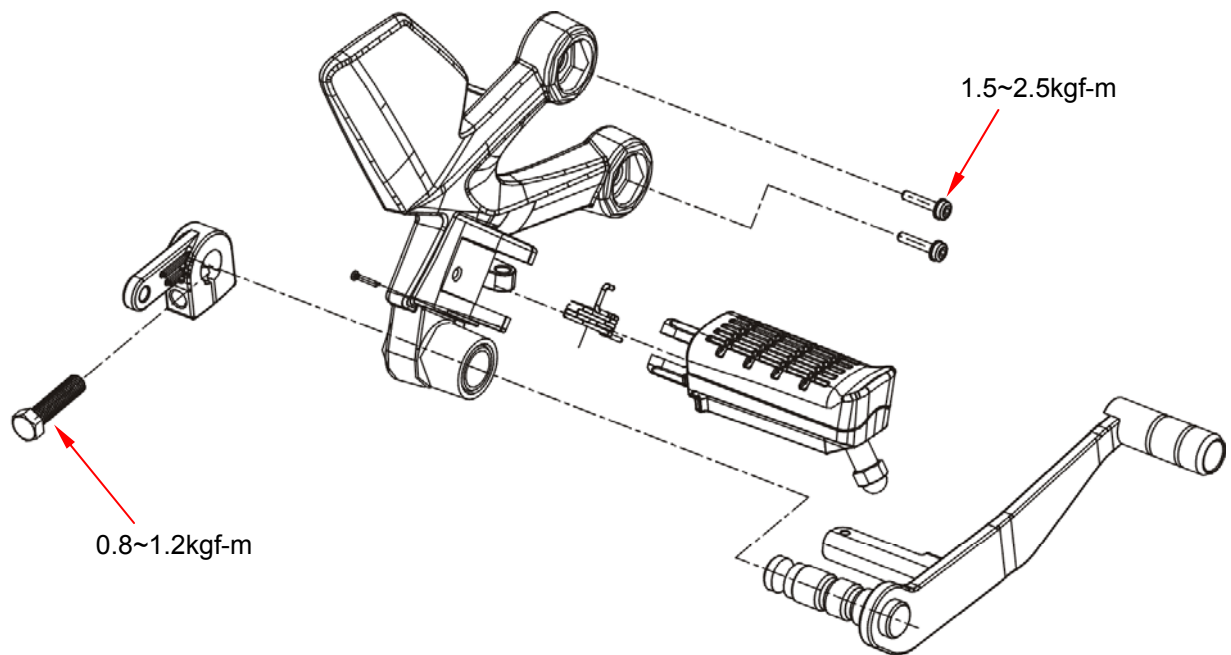

## Precautions in operation

### Caution

- Inhaling asbestos may cause disorders of respiration system or cancer, therefore, never use compressed air or dry brush to clean brake system. Use vacuum cleaner or other authorized tool instead.
- The brake caliper can be removed without removing the hydraulic system.
- After the hydraulic system is removed, or the brake system is felt to be too soft, bleed the hydraulic system.
- While refilling brake fluid, care should be taken not to let the foreign material entering the brake system.
- Do not spill brake fluid on the painted surfaces, plastic, or rubber parts to avoid damage.
- Check the operation of the brake system before riding.

### Specification

measurement : mm

Item	Standard	Service limit
Front brake disk thickness	5.00	4.50
Rear brake disk thickness	4.00	3.00
Front brake disk outer diameter	288.00	—
Rear brake disk outer diameter	222.00	—
Brake disk eccentricity	0.1	0.30
Bake pad thickness	—	Mark on brake pad

### Torque value

Brake hose bolt	3.0~4.0kgf-m
Front brake caliper bolt	3.5~4.5kgf-m
Brake disk bolt	3.7~4.3kgf-m
Air bleed valve	0.8~1.0kgf-m
Front wheel axle nut	6.0~8.0kgf-m
Rear wheel axle nut	10.0~12.0kgf-m

### Special tool

Inner bearing puller	SYM-6204020
----------------------	-------------

## Troubleshooting

### Disk brake

#### Soft brake lever

1. Air inside the hydraulic system
2. Hydraulic system leakage
3. Worn master cylinder piston
4. Poor brake caliper
5. Worn brake pad
6. Low brake fluid
7. Blocked brake hose
8. Warped / bent brake disk
9. Bent brake lever

#### Hard brake lever operation

1. Blocked brake system
2. Poor brake caliper
3. Blocked brake hose
4. Seized / worn master cylinder piston
5. Bent brake lever

#### Uneven brake

1. Dirty brake pad / disk
2. Poor wheel alignment
3. Blocked brake hose
4. Warped / bent brake disk
5. Blocked brake hose / joint

#### Tight brake

1. Dirty brake pad / disk
2. unbalanced brake disk / wheel
3. Warped / bent brake disk

#### Brake noise

1. Dirty brake pad / disk
2. Deformed brake disk
3. Poor brake caliper installation
4. Imbalanced brake disk / wheel

## Disk brake system inspection

### Inspection

Visually examine for leakage or damage. Inspect the brake hose joint for looseness. Turn the handle bar to right and left; press the cushion to see if there is any interference with the brake system.

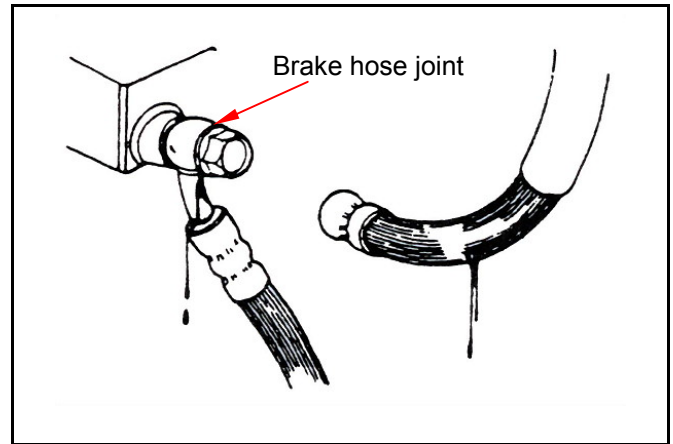

Check if the brake pads worn. Replace the brake pads if either pad is worn to the bottom of wear limit groove.

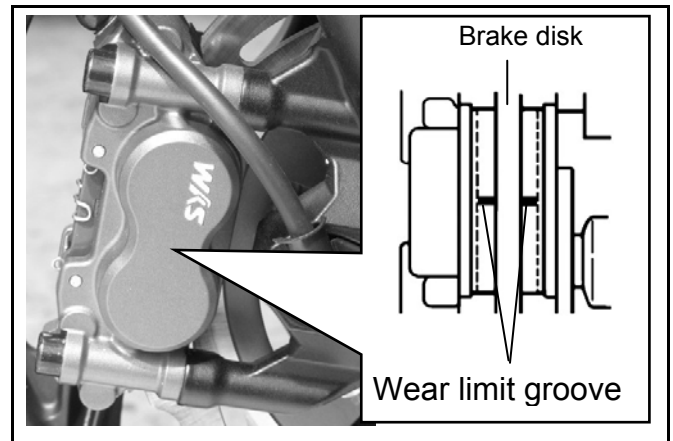

Park the vehicle on the level ground. Check the brake fluid level. Recommended Brake Fluid: WELL RUN BRAKE OIL (DOT 3).

### ⚠ Caution

- When the vehicle is inclined or just stopped, the brake fluid level could not be accurate.
- Do not mix different types of brake fluid which are not compatible with each other.
- Use the same brand brake fluid to ensure the brake efficiency.

### Adding brake fluid

Turn the handlebar to make the reservoir level before opening the reservoir cap. Cover the painted, plastic or rubber surface with a rag before performing brake system maintenance.

### ⚠ Caution

- Do not fill brake fluid over upper limit.

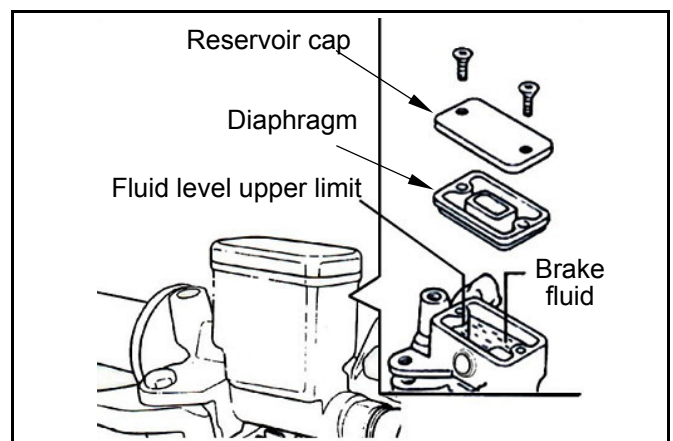
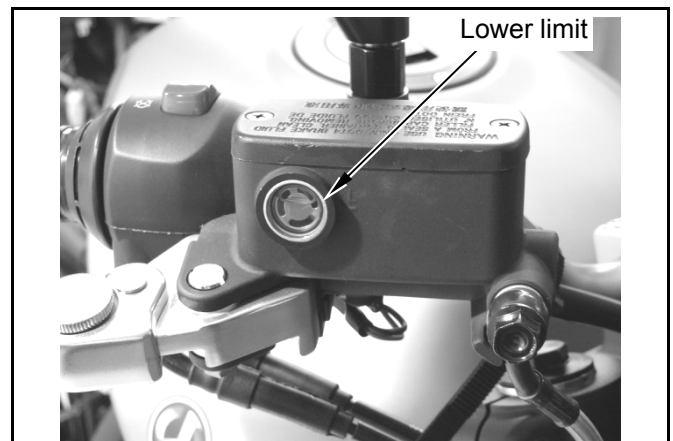

## 11. Brake System



Remove the reservoir cap and diaphragm.  
Fill the clean brake fluid.  
Clean the dirty brake disk.

### **⚠ Caution**

- Contaminated brake disk or pad decreases braking performance.
- Foreign material will clog brake system and lead to decline or malfunction of braking capability.

### **Brake fluid replacement / air bleed**

Connect a drain hose to air-bleed valve. Open the air-bleed valve. Pump the brake lever until the old brake fluid is entirely drained out. Close the air-bleed valve and add specified brake fluid into the brake fluid reservoir.

### **⚠ Caution**

- Reuse of old brake fluid will affect brake efficiency.

Connect a drain hose to the air-bleed valve, and put the other end into a container. Open the air-bleed valve around 1/4 turns, and at the same time pump the brake lever until there is no air bubble in the drain hose and also feeling resistance on the brake lever. Close the air-bleed valve when the brake system fluid filling procedure is finished. Pump the brake lever to check whether air bubble is in brake system or not. If brake is still soft, please bleed the system as described below:

1. Tightly hold the brake lever and open the drain valve around 1/4 turns, and then close the valve.

### **⚠ Caution**

- Do not release the brake lever before the air-bleed valve is closed.
- When bleeding air, frequently check fluid level to avoid air entering the brake system.

2. Release the brake lever slowly.

3. Repeat step 1 and 2 until there is no air bubble at the end of the hose. Tighten air-bleed valve.

4. Confirm the brake fluid level, add fluid if necessary.

5. Cover the reservoir cap.

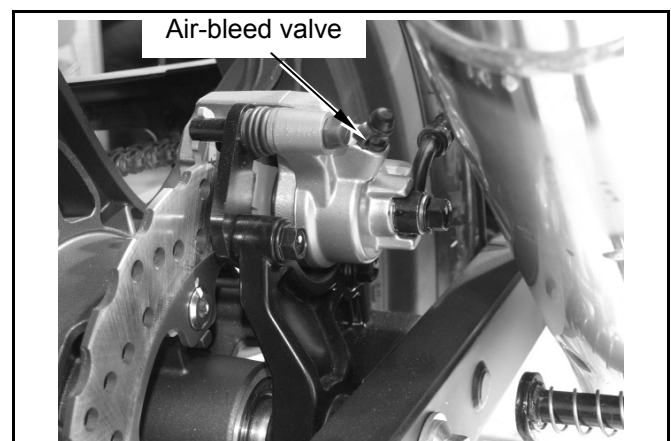
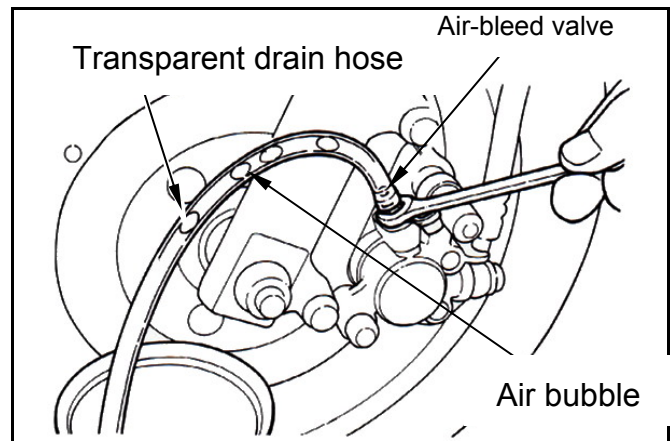
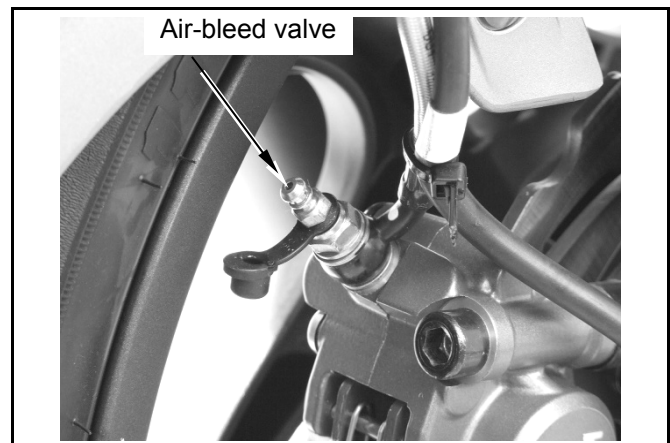
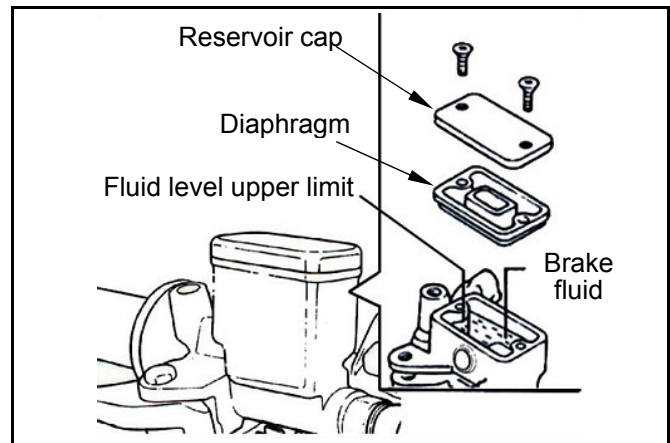

## Front brake caliper

### Removal

Place a container under the brake caliper, and loosen the brake hose bolt, drain brake fluid.

### ⚠ Caution

- Do not spill brake fluid on painted surfaces.

Remove caliper bolts, (bolt×2) remove the caliper.

Check the brake pad wear condition, replace with new brake pad if wear limit is reached.

### Installation

Install the caliper and tighten the bolts.

**Torque value : 3.5~4.5kgf-m**

## Brake pad replacement

Remove pin clips.

Remove pad pins and spring.

Remove brake pads.

Install new brake pads, pad pins, and spring.

Install pin clip.

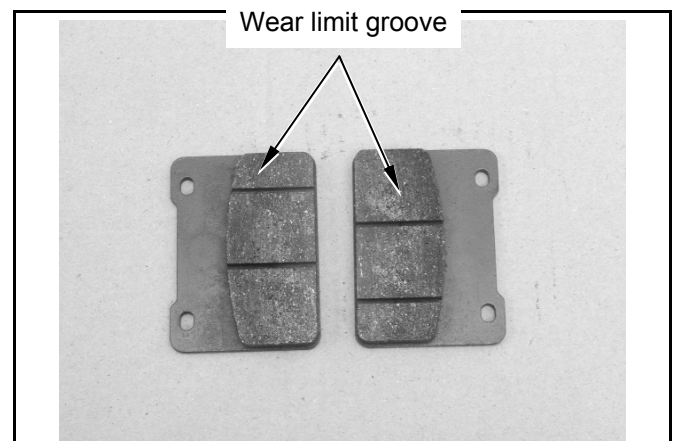
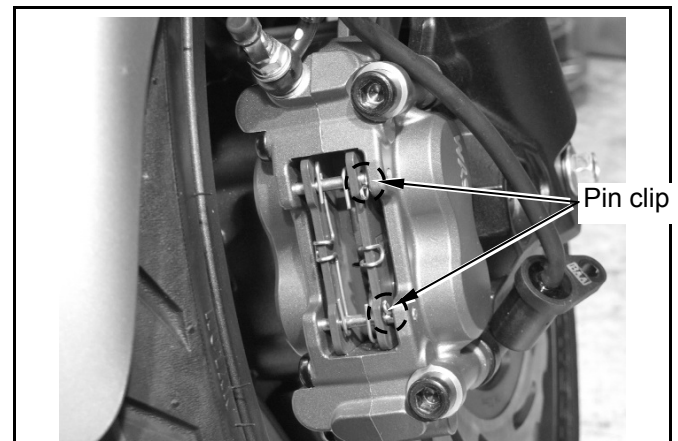
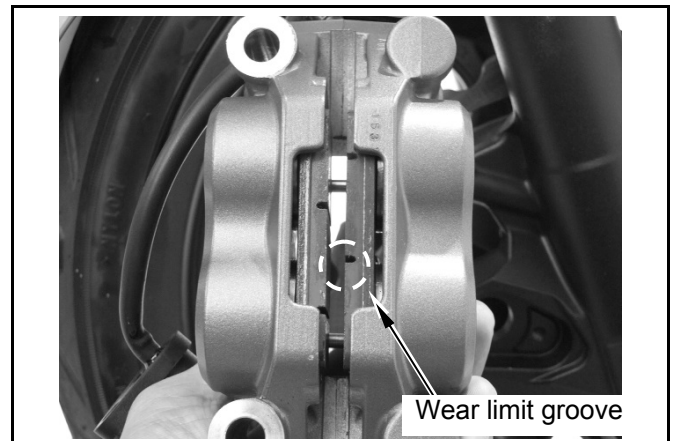
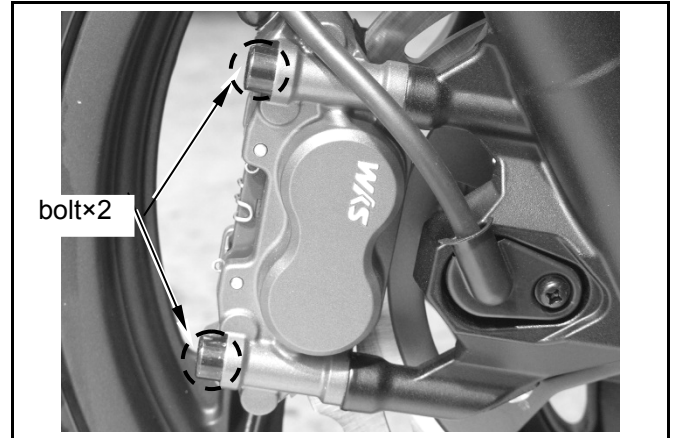

## Rear brake caliper

### Removal

Place a container under the brake caliper, and loosen the brake hose bolt, drain brake fluid.

### ⚠ Caution

- Do not spill brake fluid on painted surfaces.

Remove caliper bolts, (bolt×2) remove the caliper.

Check the brake pad wear condition, replace with new brake pad if wear limit is reached.

### Installation

Install the caliper and tighten the bolts.

**Torque value: 3.1~3.5kgf-m**

## Brake pad replacement

Remove guide bolts.

Remove brake pads.

Remove pad support.

Install pad support.

Install new brake pads.

Install guide bolts.

Install brake caliper, tighten caliper bolts.

**Torque value: 1.5~2.0kgf-m**

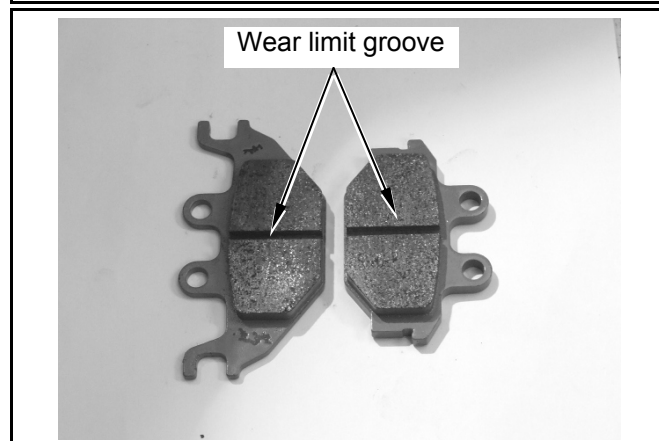
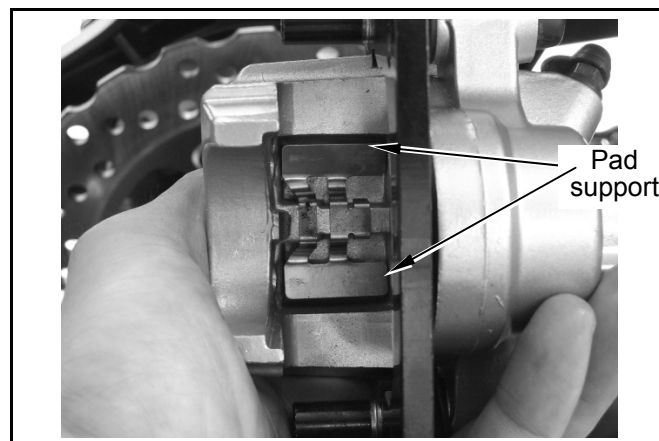
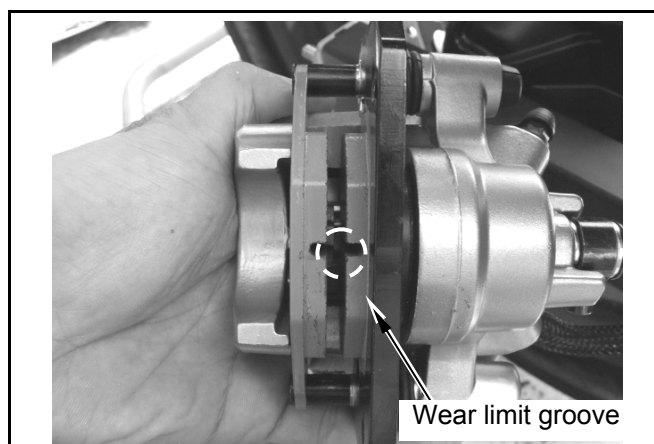
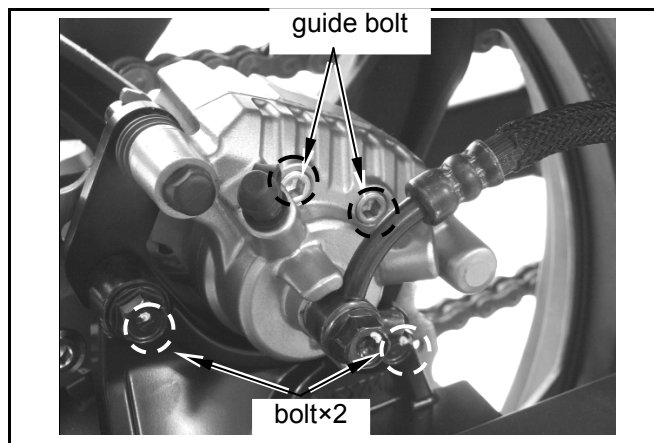



### Brake disk

#### Inspection

Visually check if the brake disk worn or damaged.

Measure the thickness of the disk at several places. Replace the disk if it has exceeded the service limit.

Remove the brake disk from wheel.  
Check if the disk for deformed or bent.

#### Caution

- The dirty brake pad or disk will reduce the brake performance.
- Brake pad includes the asbestos ingredient. Do not use compressed air to clean the brake system. The operator should put on gauze mask and glove, use vacuum cleaner to clean it.

**Front brake disk service limit: 4.5 mm**

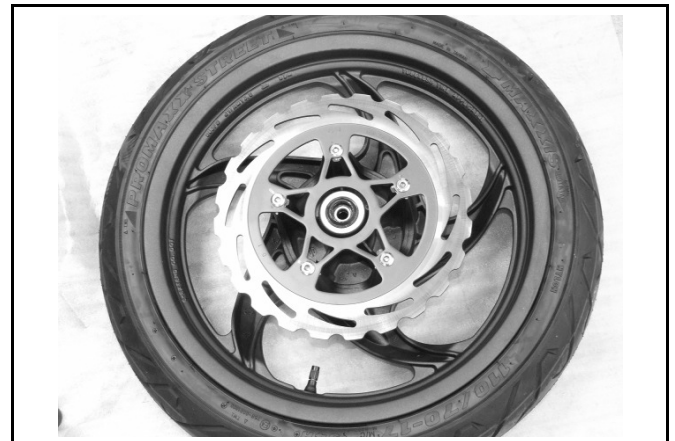
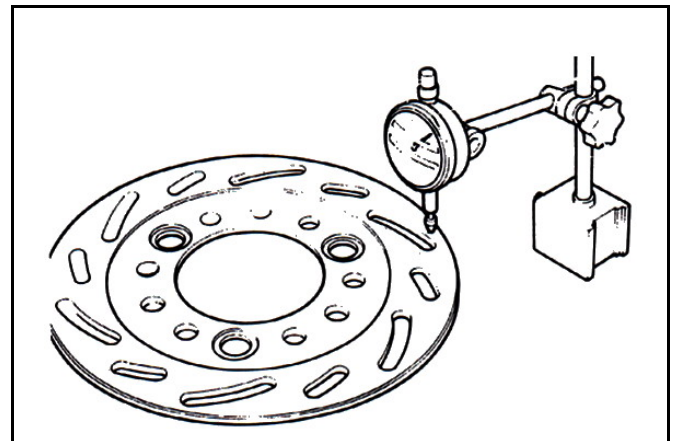
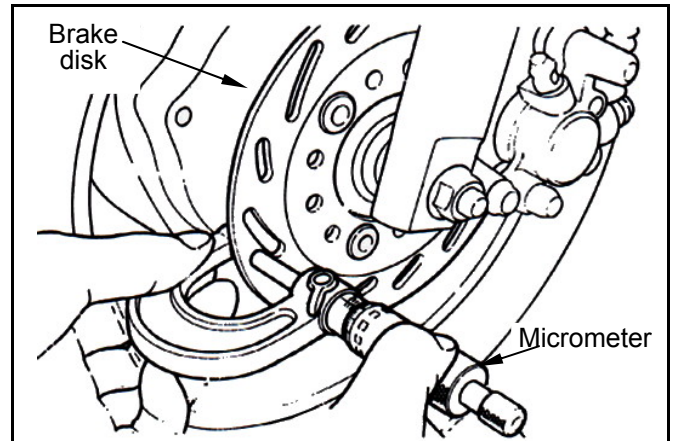

**Rear brake disk service limit: 3.0 mm**

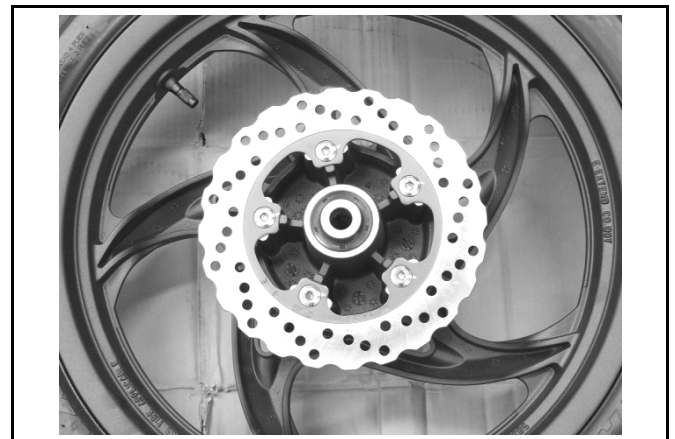

### Brake master cylinder

#### Removal

#### Caution

- Do not let foreign materials entering the cylinder.

Remove back mirror.

Disconnect brake light coupler.

Drain brake fluid.

Remove the brake lever from brake master cylinder.

Remove brake hose.

Remove brake master cylinder from handlebar. (bolt×2).

Clean the master cylinder with recommended brake fluid.

#### Installation

Install brake master cylinder on handle bar, tighten bolts. (bolt×2).

**Torque value: 0.8~1.2kgf-m**

Install brake lever, connect brake light coupler.

Apply 2 new seal washers, install brake hose. Tighten the brake hose bolt to the specified torque value.

**Torque value: 3.0~4.0kgf-m**

Make sure the hose is installed correctly.

#### Caution

- Improper routing may damage the hose and wire.
- Twisted brake hose and wire may reduce brake performance.

Add specified brake fluid and bleed the system.

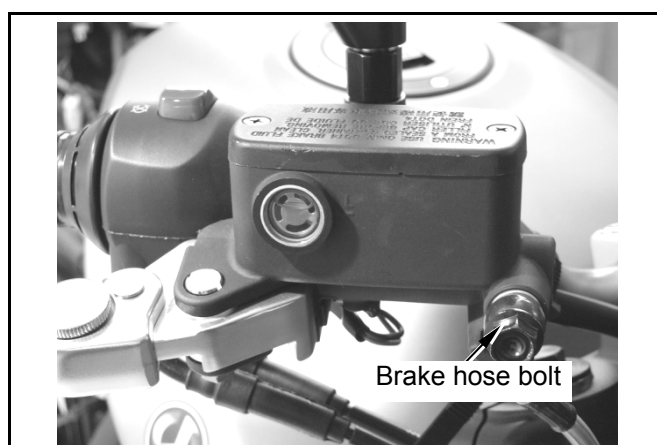

Mechanism Diagram .....	12-1	Front Wheel .....	12-6
Precautions in Operation .....	12-2	Front Fork .....	12-9
Troubleshooting .....	12-3	Steering Stem .....	12-12
Steering Handlebar .....	12-4		

## Mechanism diagram

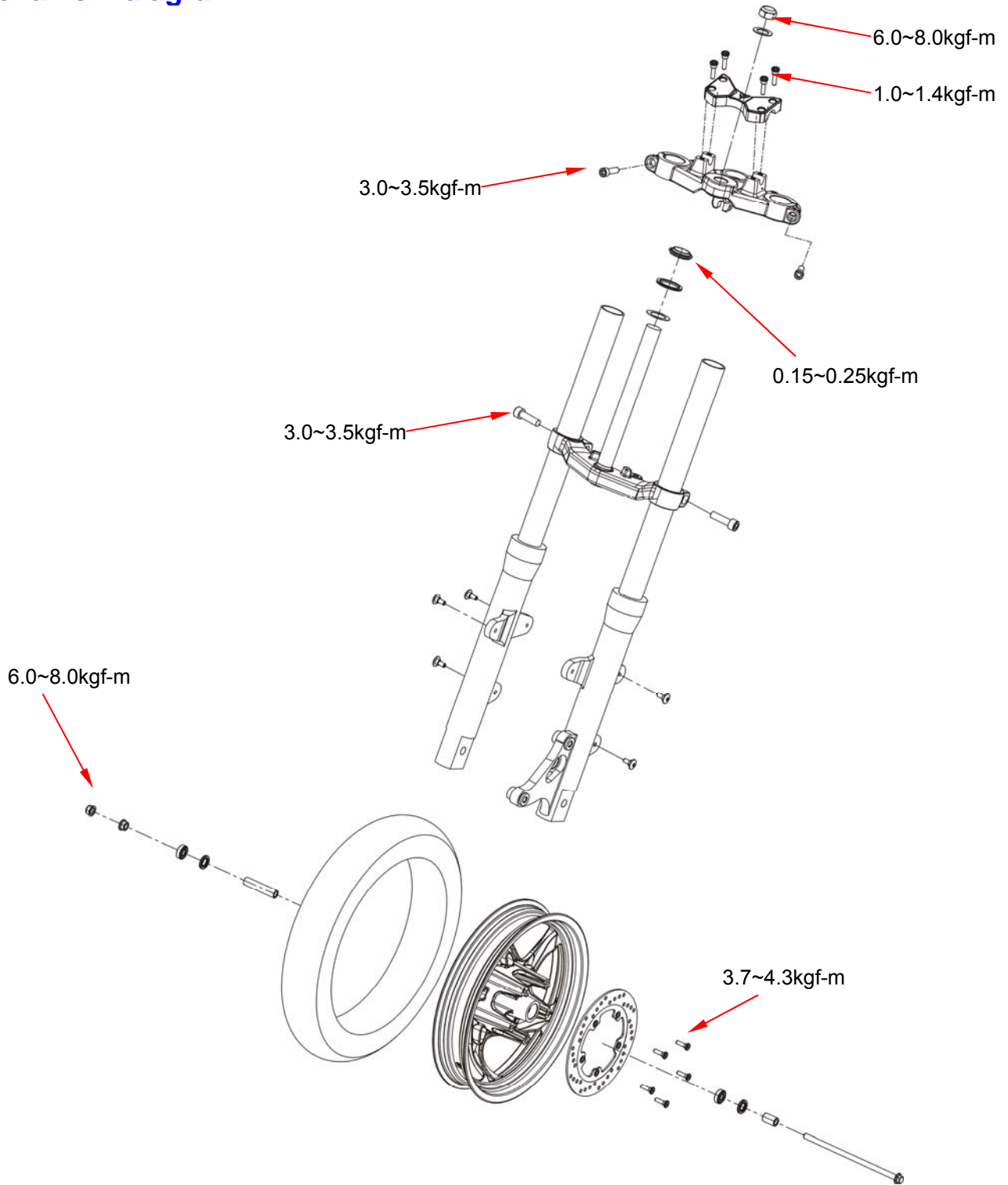

### Precautions in operation

#### General information

- While removing the front wheel, hold the engine bottom with a hanger to lift the front wheel.
- During maintaining, do not stain brake pads with any oil or grease.
- The brake caliper can be removed without removing the hydraulic system.
- After the hydraulic system is removed, or the brake system is felt to be too soft, bleed the hydraulic system.
- While refilling brake fluid, care should be taken not to let the foreign material entering the brake system.
- Do not spill brake fluid on the painted surfaces, plastic, or rubber parts to avoid damage.
- Check the operation of the brake system before riding.

#### Caution

- Inhaling asbestos may cause disorders of respiration system or cancer, therefore, never use compressed air or dry brush to clean brake system. Use vacuum cleaner or other authorized tool instead.

#### Specification

measurement : mm

Item		Standard	Service limit
Wheel axle runout		–	0.2
Wheel rim runout	Axial	–	2.0
	Radial	–	2.0

#### Torque value

Front wheel axle locknut	6.0~8.0kgf-m	Front brake hose bolt	3.0~4.0kgf-m
Steering handlebar bolt	1.0~1.4kgf-m	Air bleed valve	0.8~1.0kgf-m
Steering head thread comp	0.15~0.25kgf-m	Brake disk fix bolt	3.7~4.3kgf-m
Steering stem locknut	6.0~8.0kgf-m	Front brake caliper bolt	3.5~4.5kgf-m
Front fork bolt	3.0~3.5kgf-m		

#### Special tool

Cone race puller

Steel ball race driver 32×35mm

Steel ball race driver 42×47mm

Inner bearing puller      SYM-6204020

Steering stem locknut socket wrench      SYM-5320000, SYM-5320010

### Troubleshooting

#### Steering mechanism / front fork

##### Hard steering

- Steering stem nut too tight
- Worn or damaged steering ball bearing / seat
- Insufficient tire pressure

##### Steering handlebar tilted

- Incorrect fork adjustment
- Bent forks
- Bent wheel axle
- Damaged tire

##### Front wheel runout

- Bent wheel rim
- wheel axle locknut loosened
- Worn tire
- Worn or damaged front wheel bearing

##### Soft suspension

- Worn fork spring
- Fork seal leakage

##### Hard suspension

- Bent fork pipes
- Excessive fork fluid

##### Front suspension noise

- Bent fork pipes
- Insufficient fork fluid
- Loosened suspension

### Steering handlebar

#### Removal

Loosen the throttle cable locknut. Remove the right handle switch screws. (screw×2)。

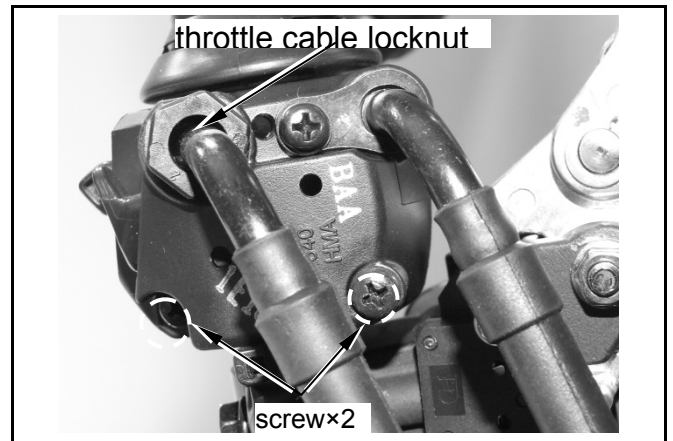

Remove the throttle cable. Remove the throttle grip and right handle switch.

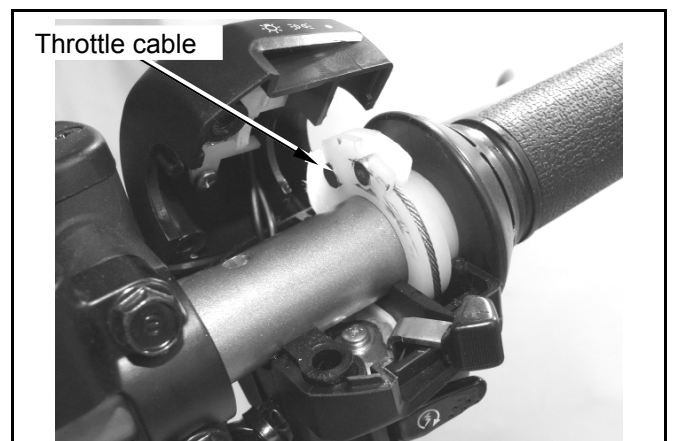

Remove the front brake master cylinder. (bolt ×2)



Remove the left handle switch. (screw x2)



Loosen the clutch cable locknut and adjusting nut.

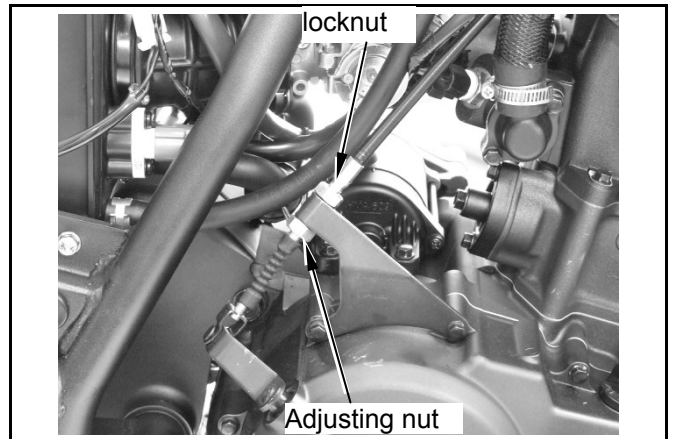

Remove the clutch lever pivot bolt. Remove the clutch lever and clutch cable.  
Remove the clutch lever socket. (bolt x2)  
Remove the handlebar bolts and holders. (bolt x4)  
Remove the handlebar.

### Installation

Install in the reverse order of removal.

**Torque value:**

**Steering handlebar bolt 3.0~3.5kgf-m**

Lubricate switches, throttle grip, and throttle cable when installing.

Align the salient on the switch and the intaglio on the handlebar holder.

After the handlebar is installed, confirm and adjust :

- throttle grip operation and free play
- meter, electrical parts operation

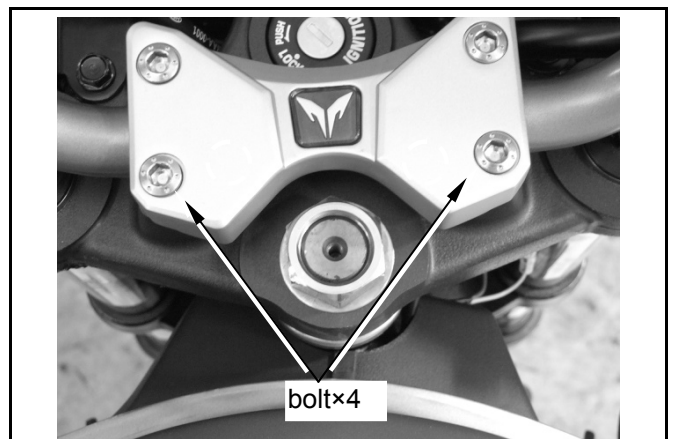
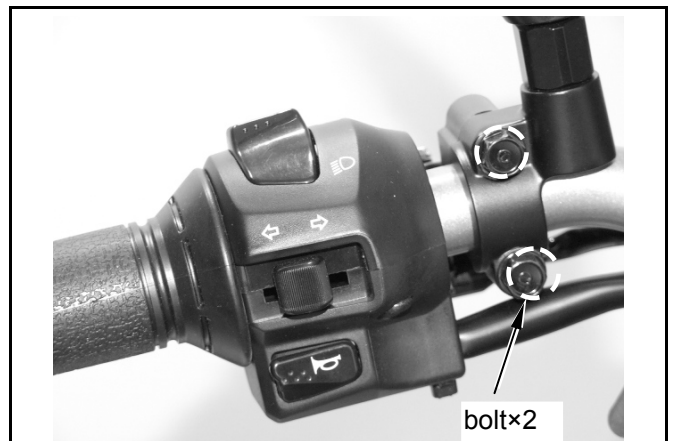

## 12. Steering / Front wheel / Front fork



### Front wheel

#### Removal

Use a bracket to hold the bottom of engine and let the front wheel away from the ground.  
Remove the front wheel axle locknut.  
Pull out the front wheel axle.  
Remove the front wheel and side collar.

#### ⚠ Caution

- Do not pull the front brake lever when the front wheel is removed to prevent the brake pads from being pushed out.

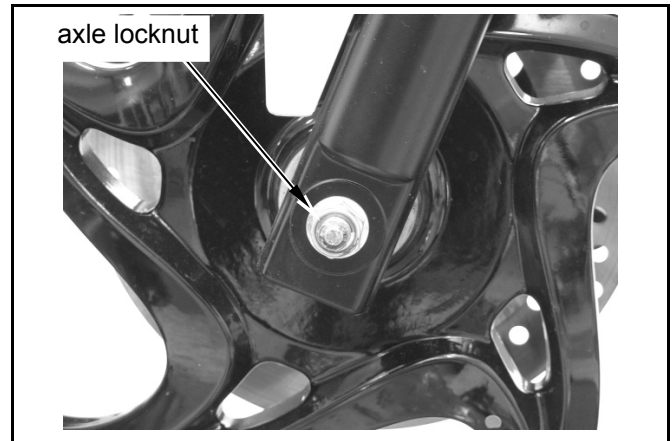

#### Inspection

##### Wheel axle

Put the axle on a V-block and measure the run out.

**Service limit: 0.2 mm**

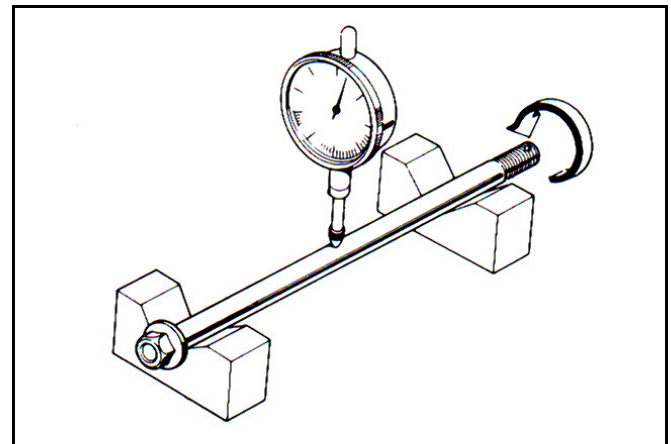

##### Bearing

Rotate the bearings to check if the bearings rotate smoothly and silently.  
Check if the outer ring of the bearing fixes firmly on the wheel hub.  
Replace the bearing if there is excessive noise, roughness, or looseness.

#### ⚠ Caution

- The bearings should be replaced in pair.

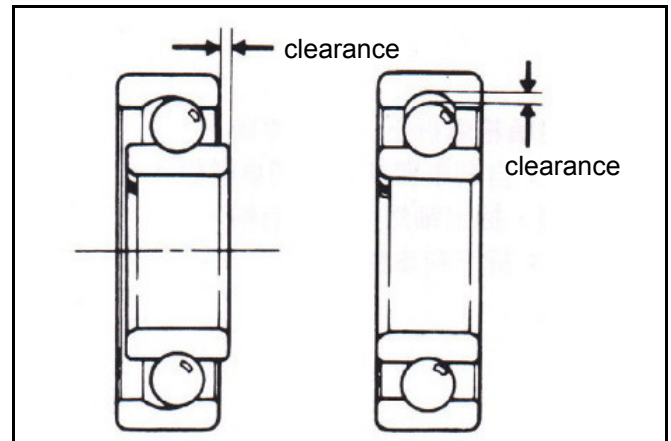

##### Wheel rim

Place the rim in a rotating stand.  
Spin the rim by hand and measure the runout by using a dial indicator.

**Service limit: radial 2.0mm  
axial 2.0mm**

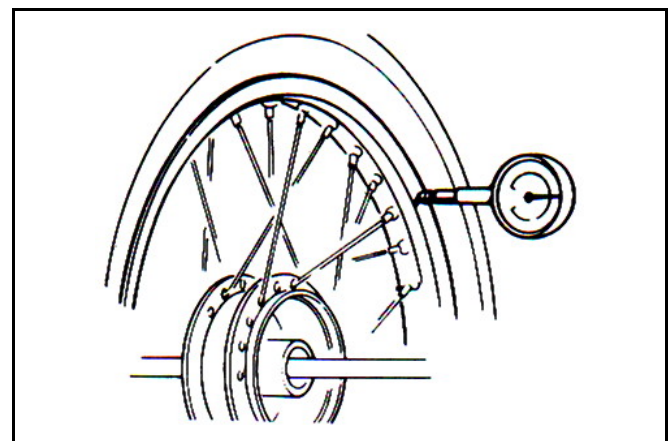



### Disassembly

Remove the brake disk. (bolt×5)。

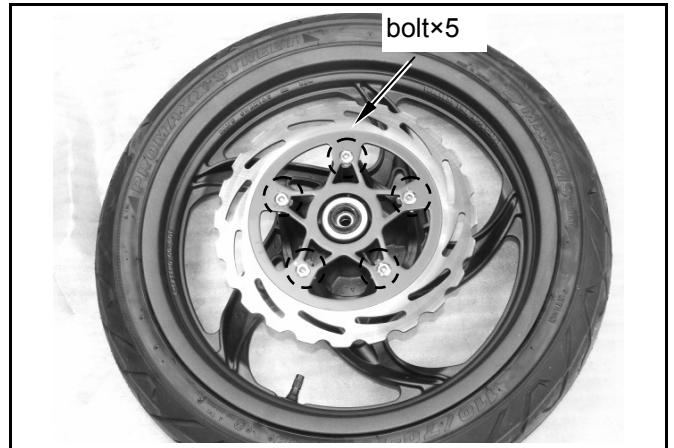

Pull out the left side bearing and oil seal by using the inner bearing puller.  
Remove the distance collar.  
Pull out the right side bearing and oil seal by using the inner bearing puller.

### Special tool

**Inner bearing puller** SYM-6204020

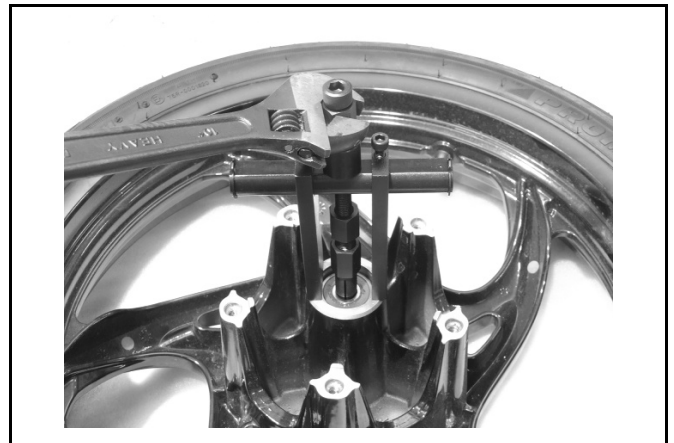

### Assembly

Install in the reverse order of removal.  
Apply grease to the wheel hub / bearing contact surface.  
Install the left side bearing.  
Install the distance collar and the right side bearing.

### ⚠ Caution

- Do not use a used bearing; replace the bearings in pair when removed from wheel hub.
- The bearing cannot lean to one side during installation.

### Tool :

Bearing driver

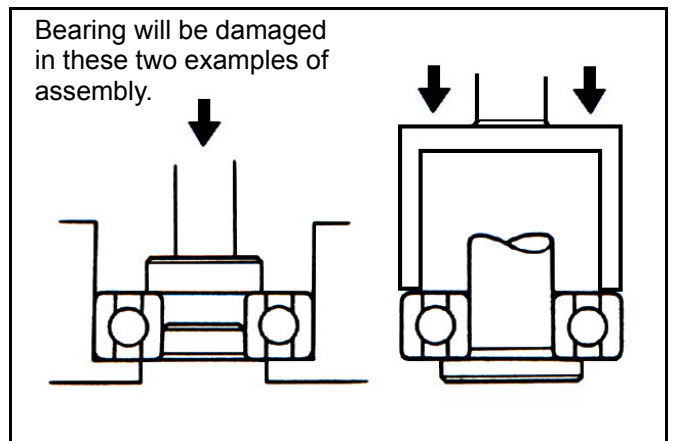

### Installation

Apply grease to the inner and outer side of oil seal and install oil seal into the wheel hub.

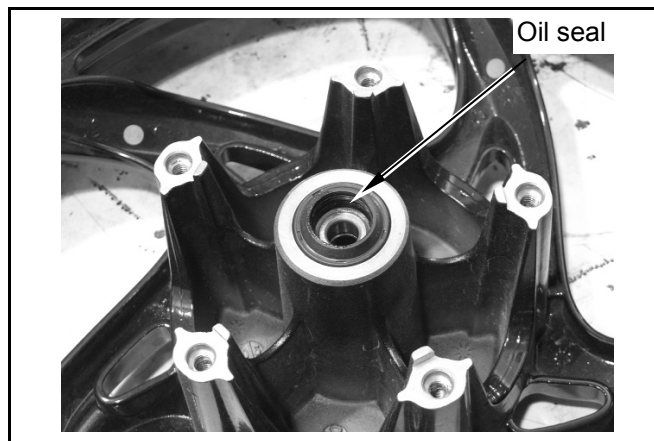

Install brake disk. (bolt×5).

**Torque value: 1.4~1.6kgf-m**

Install side collar.

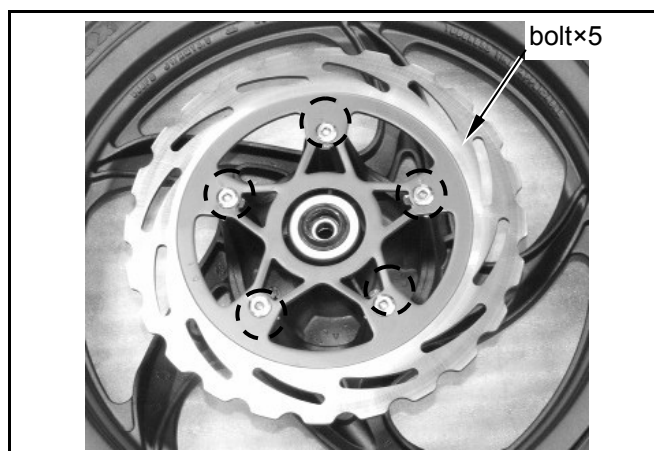

### Caution

- Contaminated brake pad will decrease braking efficiency; therefore grease cannot be applied to brake pad and brake disk.

Install the front wheel axle from the right cushion.

Install the axle locknut and tighten the locknut to the specified torque.

**Torque value: 6.0~8.0kgf-m**

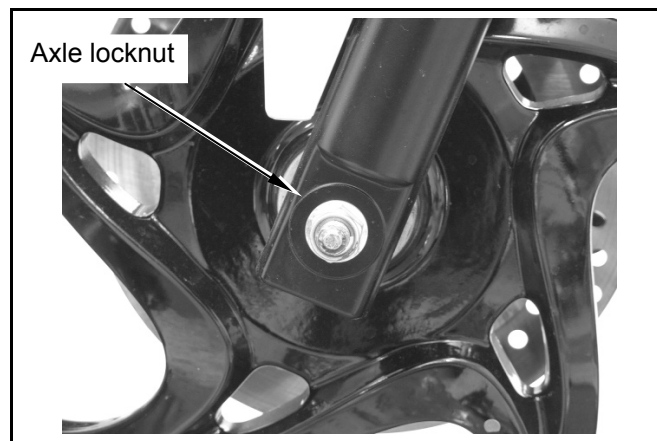

### Front fork

#### Disassembly

Remove the front wheel, speed sensor and front brake caliper.

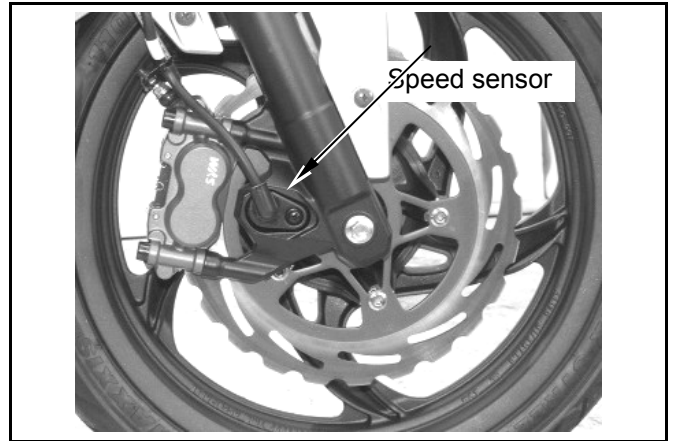

Remove the front fender. (bolt×6)。

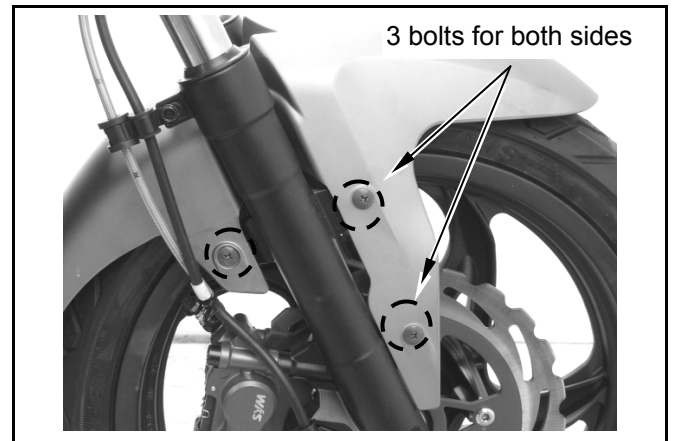

Loosen the front fork bolt on the top bridge. (bolt×2)。

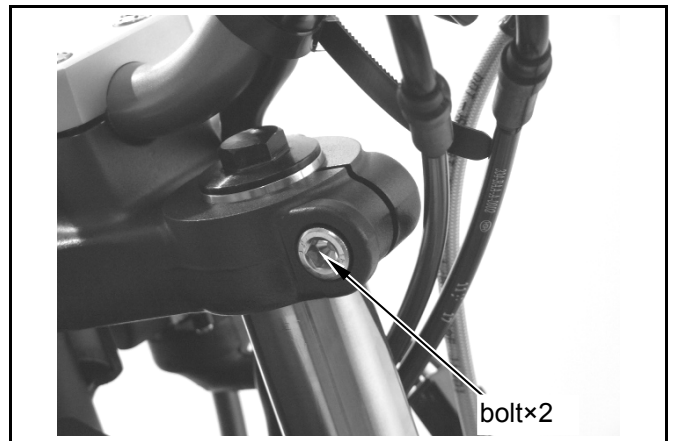

Loosen the front fork bolt on the steering stem. (bolt×2) Remove the front fork.

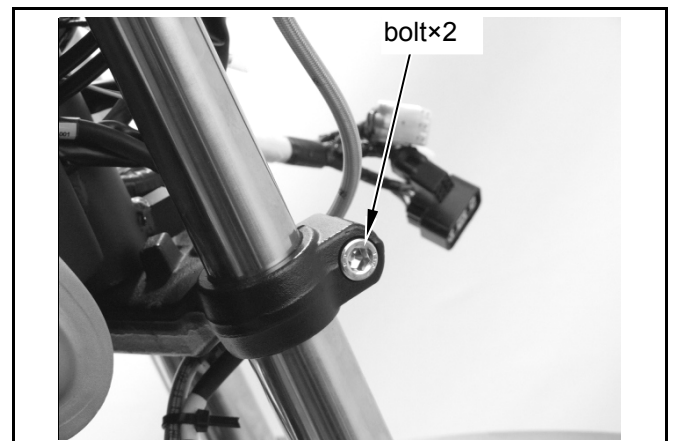

### Front fork inspection / oil seal replacement

Push the fork pipe for several times to check if there is any oil leakage or excessive noise. Check if there is any scratch on the fork pipe if oil leakage happens. Replace the front fork if there is a scratch on the fork pipe.

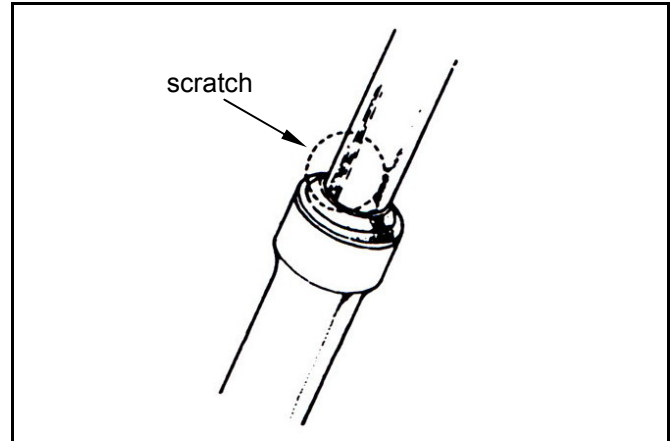

If there is oil leakage but without scratch on the fork pipe, replace the oil seal. Pour out the fork fluid. Remove the oil seal stopper ring and then remove the old oil seal.

#### Caution

- Do not damage the fork pipe when removing the oil seal.

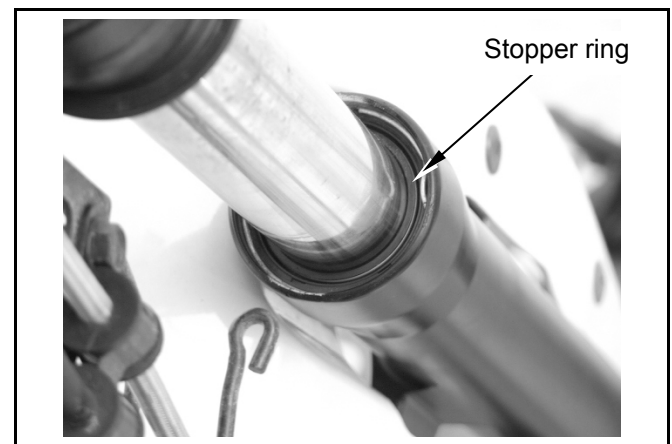

Coat the inner side of the new oil seal with cushion oil and then put in the fork pipe. Install the oil seal to the right position by using an oil seal driver. Clip the stopper ring.

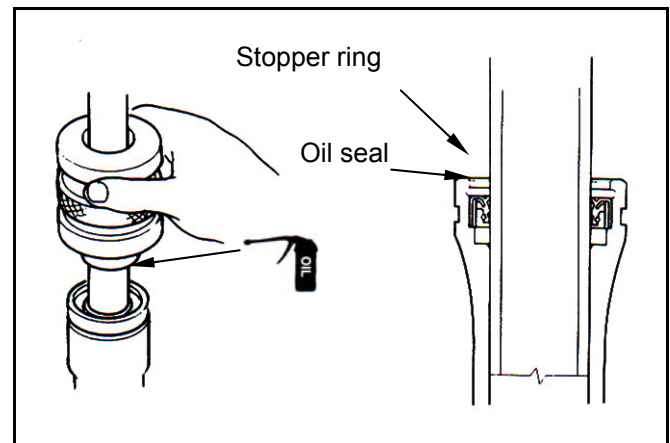

Adjust the fork fluid capacity if the front fork is too hard or too soft.

**Cushion oil : BRAMAX CUSHION OIL**  
**Capacity: 160~180c.c.**

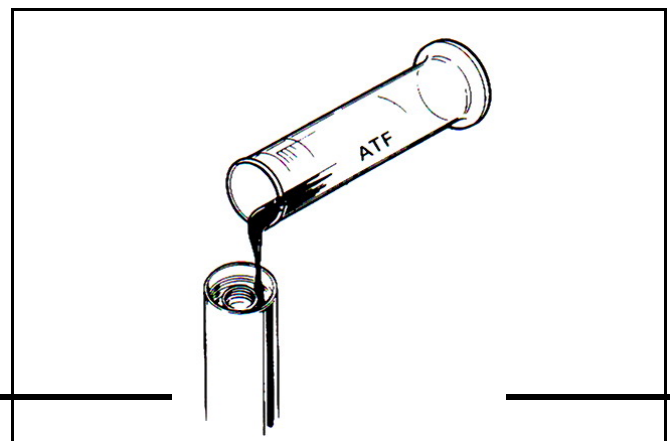

### Installation

#### Caution

- The installing will be easier by rotating the fork pipe.

Install the fork pipe from the bottom of the front fork. Align the fork pipe cap with the top bridge.

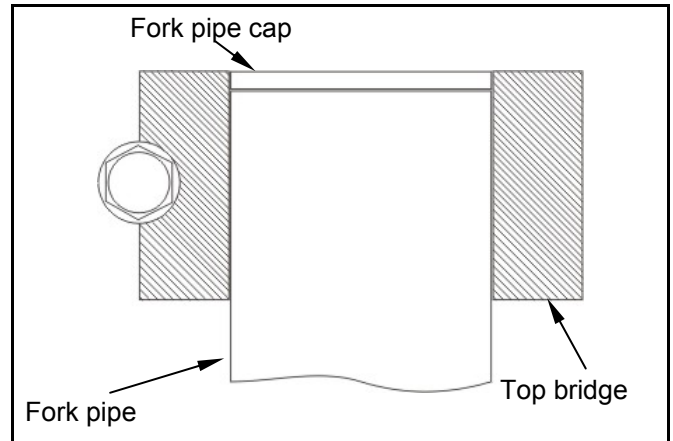

Hold the fork pipe by hand and tighten the front fork upper bolt. (bolt×2).

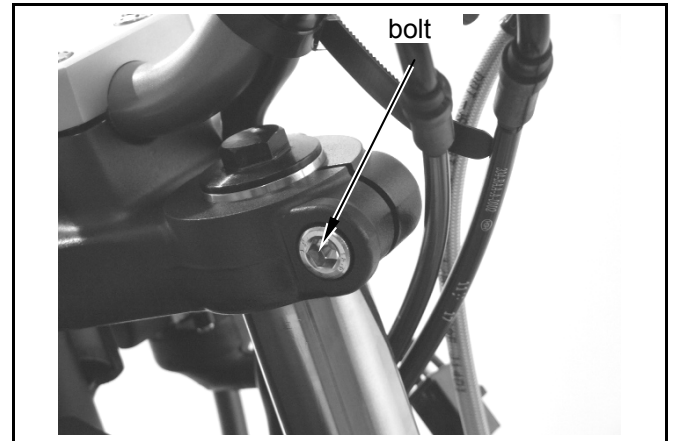

Tighten the fork bolt on the steering stem. (bolt×2)

**Torque value: 3.0~3.5kgf-m**

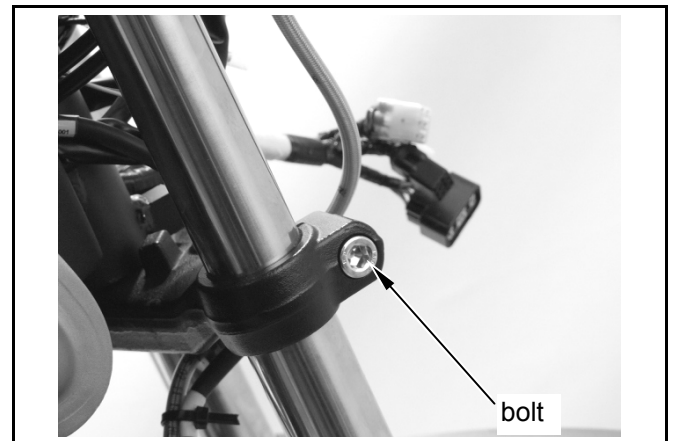

Tighten the front fork upper bolt. (bolt×2)

**Torque value: 3.0~3.5kgf-m**

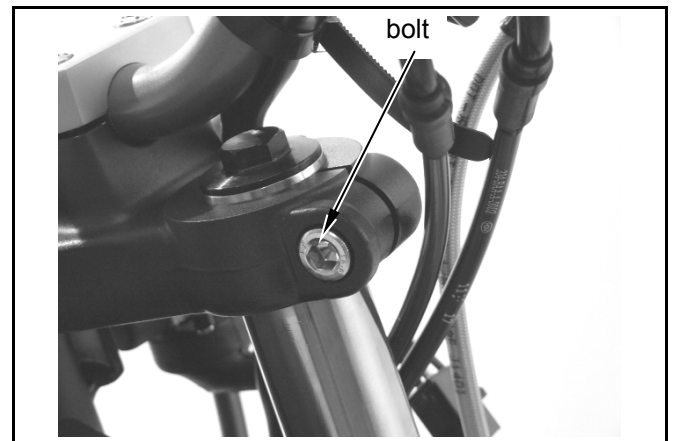

## 12. Steering / Front wheel / Front fork



### Steering stem

#### Removal

Remove the meter, headlight, steering handlebar, front wheel, front brake and front fork.

Remove top bridge locknut. (nut×1)

Remove the steering stem locknut and steering upper cone race by using stem locknut socket wrench.

#### Special tool:

**Stem locknut socket wrench** SYM-5320000

Remove the steering stem.

#### ⚠ Caution

- Keep the steering steel balls in a container to avoid missing them.

Remove the steering upper ball race by rubber hammer.

Remove the steering bottom ball race by driver.

Remove the steering bottom cone race from the steering stem.

#### ⚠ Caution

- Do not damage the frame and steering stem.

#### Installation

Install a new steering bottom cone race onto the steering stem and lubricate with grease. Install the steering upper / bottom ball race to the right position.

#### ⚠ Caution

- Do not let the ball race lean on one side during installation.

Coat the upper / bottom ball race with grease and install the steering balls.

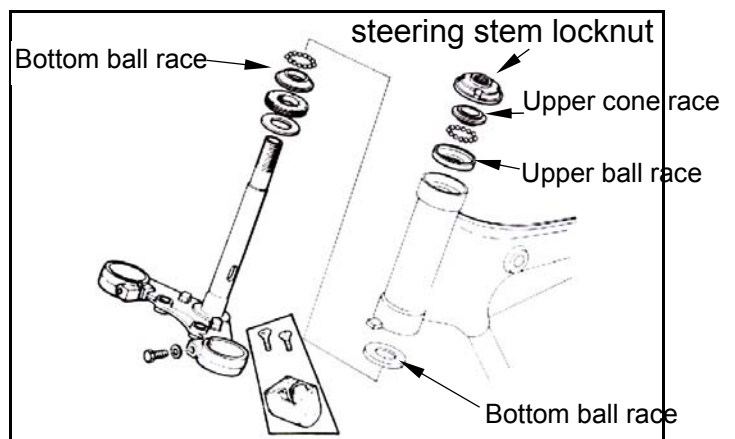
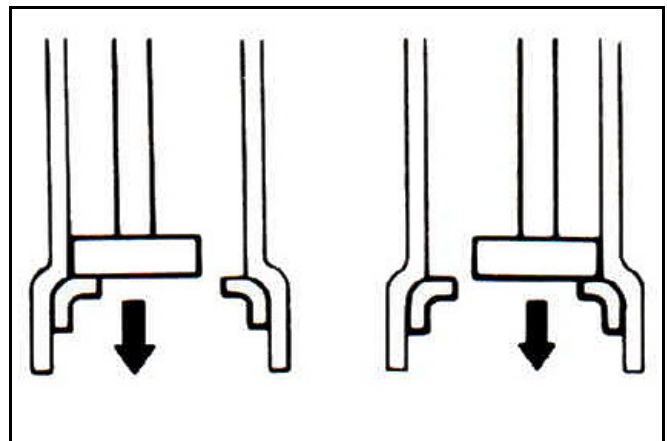
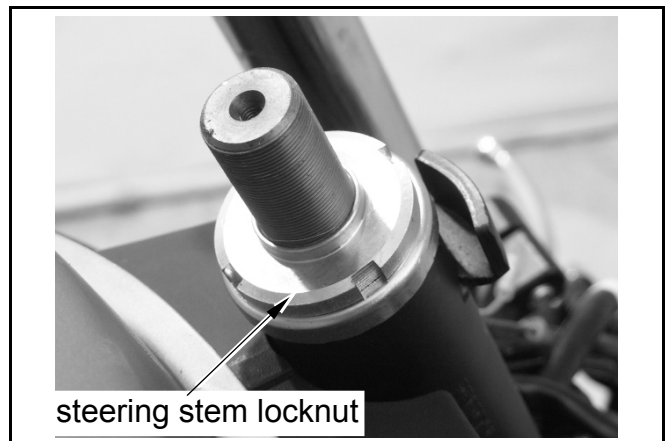
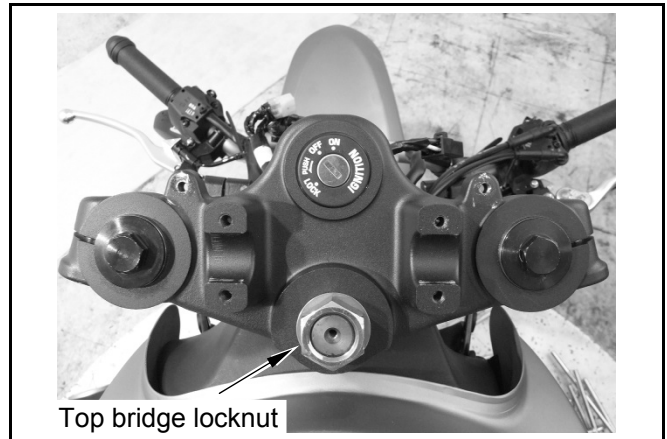

Install the steering stem into the frame.  
Lubricate the steering upper cone race.  
Tighten the upper cone race and steering stem locknut to the steering stem till the steering balls touch the upper cone race closely.  
Turn the upper cone race counterclockwise 1/2 circle and then tighten it with specific torque value.  
(1/4~3/8 circle)

**Special tool:**

**Stem locknut socket wrench** SYM-5320000

**Top bridge locknut socket** SYM-5320010

**Torque value: 0.15~0.25kgf-m**

**⚠ Caution**

- Do not over tighten upper cone race or the steering ball race may be damaged.

Install the top bridge and tighten the nut.

**Torque value: 6.0~8.0kgf-m**

**⚠ Caution**

- After installation, check if the steering stem rotate freely without vertical clearance.

Install other parts in the reverse order of removal.

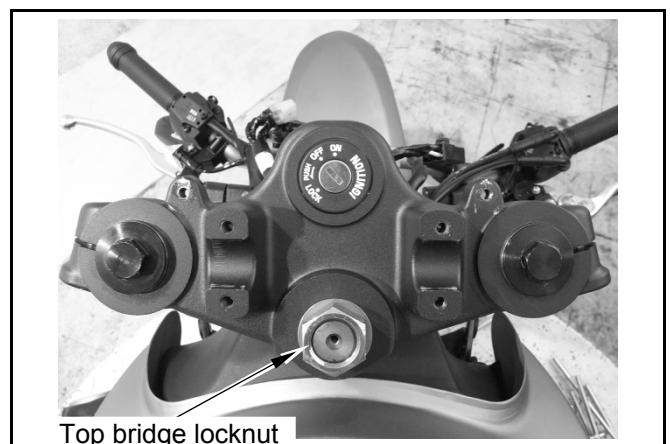
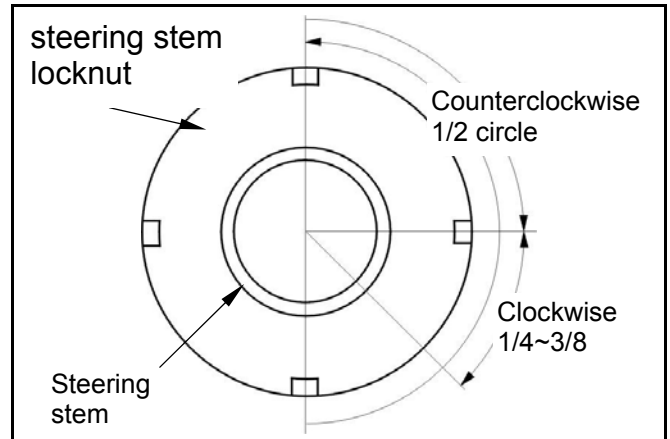

---

**NOTE:**



Mechanism Diagram .....13-1	Drive Chain / Sprocket / Flange ..13-6
Precautions in Operation .....13-2	Rear Cushion .....13-9
Troubleshooting.....13-2	Swingarm .....13-10
Rear Wheel .....13-3	

## Mechanism diagram

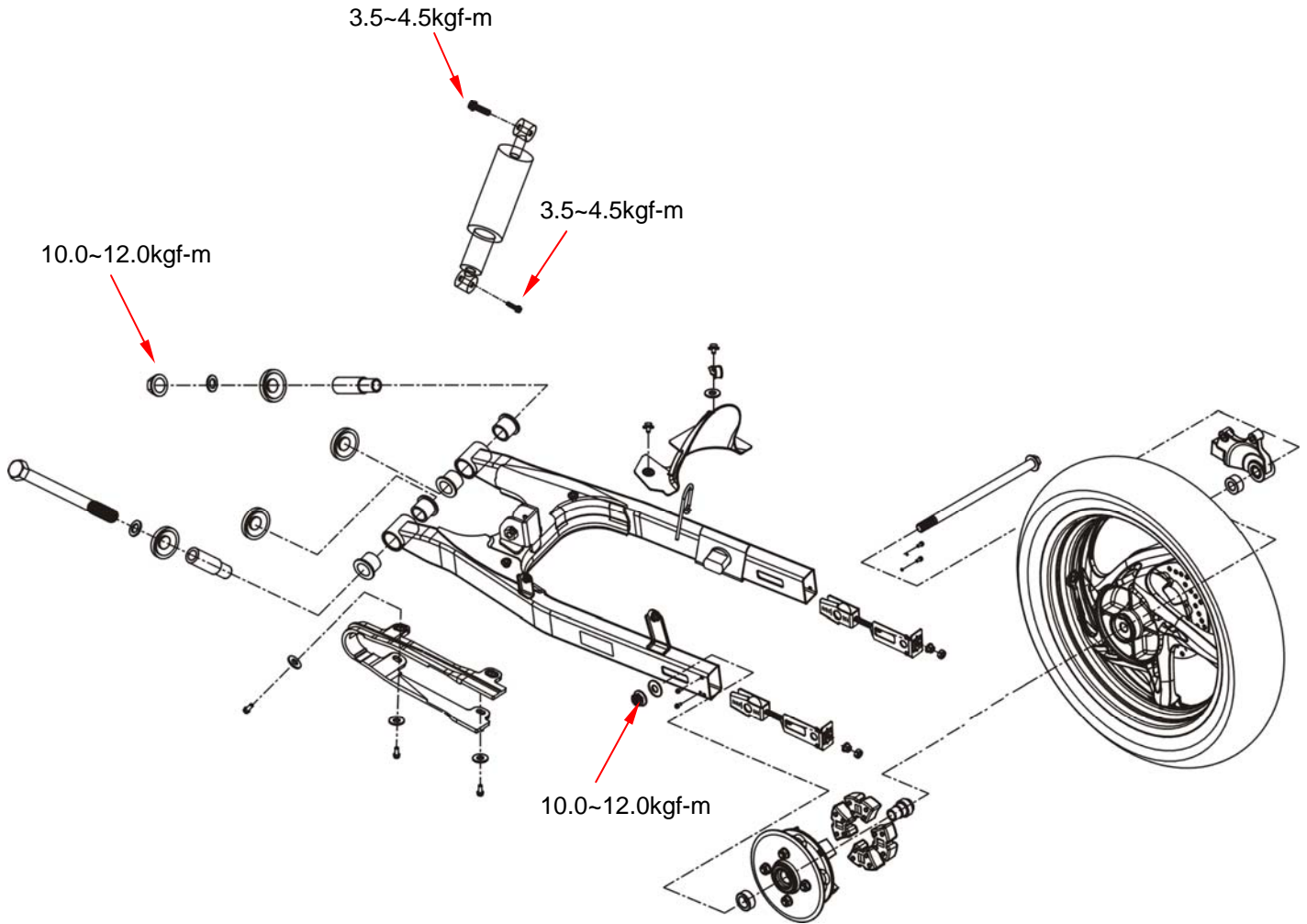

## Precautions in operation

### General information

Refer to the service manual of tire for the information of tire removal, repair and installation.

### Specification

measurement: mm

Item	Standard	Service limit
Axle runout	–	0.2
Wheel rim runout	Radial	2.0
	Axial	2.0
Drive chain slack	–	10~20

### Torque value

Rear drive sprocket bolt	2.7~3.0kgf-m
Rear wheel axle nut	10.0~12.0kgf-m
Rear cushion upper bolt	3.5~4.5kgf-m
Rear cushion lower bolt	3.5~4.5kgf-m

### Special tool

Inner bearing puller	SYM-6204020
Stem locknut socket wrench	SYM-5320000
Rubber bush puller / driver	SYM-1120310

## Troubleshooting

### Rear wheel wobbling

- Bent rim
- Faulty rear tire
- Incorrect wheel axle tightening

### Too soft suspension

- Weak cushion spring
- Faulty rear cushion

### Too hard suspension

- Damaged rubber bush
- Bent rear cushion

### Rear suspension noise

- Incorrect cushion nut tightening
- Damaged rubber bush
- Cushion fluid leakage
- Bent rear cushion / spring

### Poor brake efficiency

- Poor brake adjustment
- contaminated brake pad
- Worn brake pad

### Rear wheel

#### Removal

Remove the rear brake caliper. (boltX2)

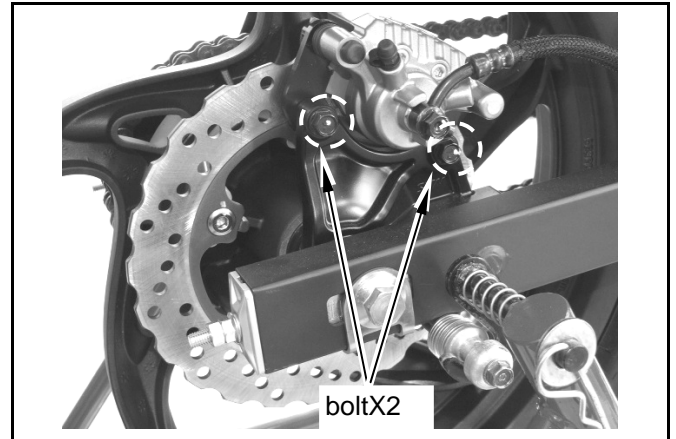

Loosen the drive chain adjusting nuts on both sides.

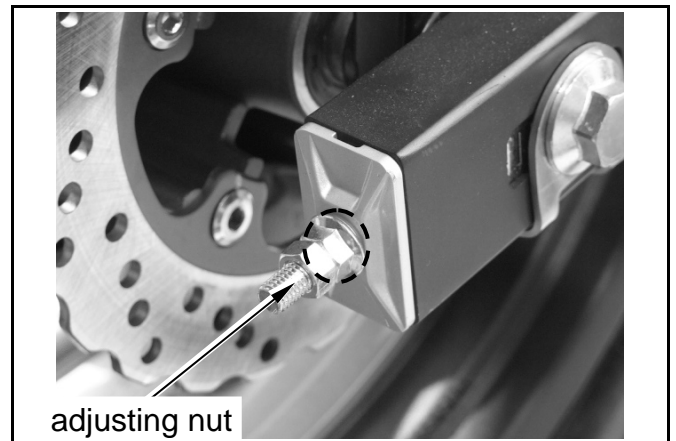

Remove the rear axle locknut.

After removing rear axle, remove the rear wheel, right / left side collar, chain adjuster, and brake disk.



## 13. Rear wheel / Rear cushion



### Inspection

#### Wheel axle

Put the axle on a V-block and measure the run out.

**Service limit: 0.2 mm**

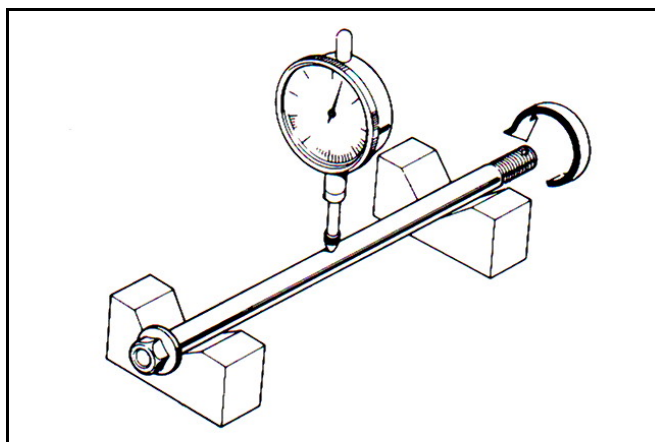

#### Bearing

Rotate the bearings to check if the bearings rotate smoothly and silently.

Check if the outer ring of the bearing fixes firmly on the wheel hub.

Replace the bearing if there is excessive noise, roughness, or looseness.

#### Caution

- The bearings should be replaced in pair.

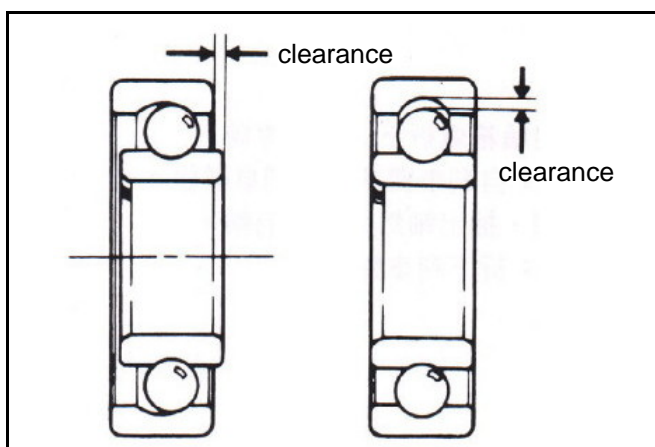

#### Wheel rim

Place the rim in a rotating stand.

Spin the rim by hand and measure the runout by using a dial indicator.

**Service limit: radial 2.0mm**

**axial 2.0mm**

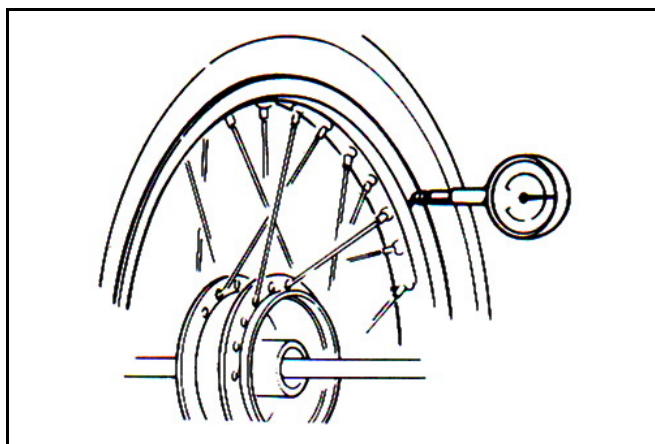

### Rear wheel installation

Install in the reverse order of removal.  
Adjust drive chain slack. (refer to ch 2)  
Tighten rear wheel washer nut.

Tighten axle locknut. (nutx1、PINx1)  
Torque value: 10.0~12.0kgf-m

Install the caliper.

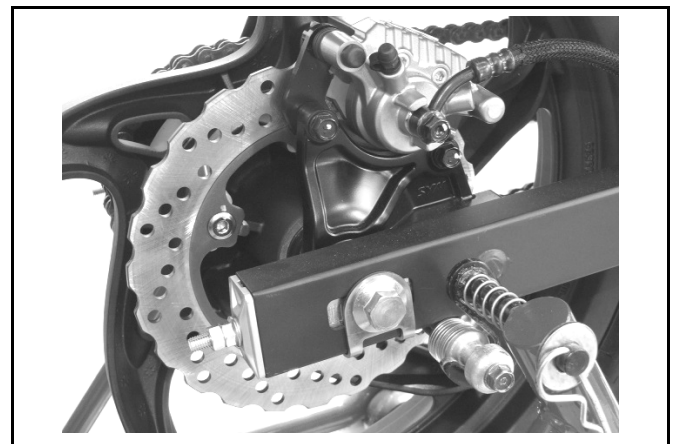
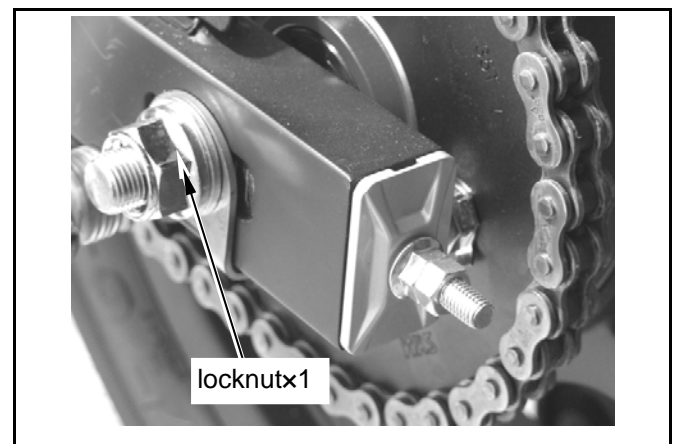
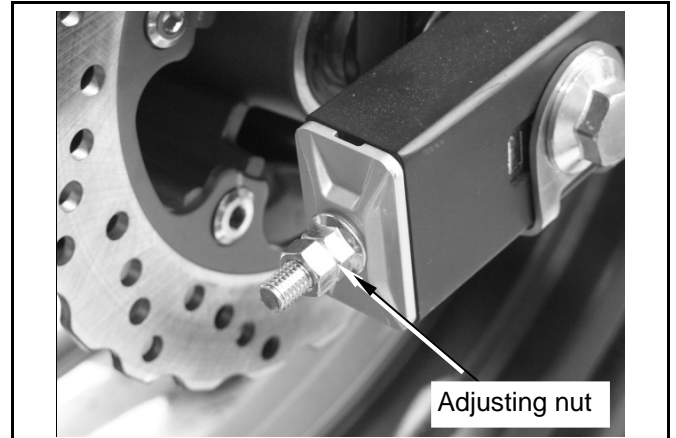

## 13. Rear wheel / Rear cushion



### Drive chain / sprocket / flange

#### Drive chain / sprocket removal

Remove the left crankcase rear cover. (boltx2)

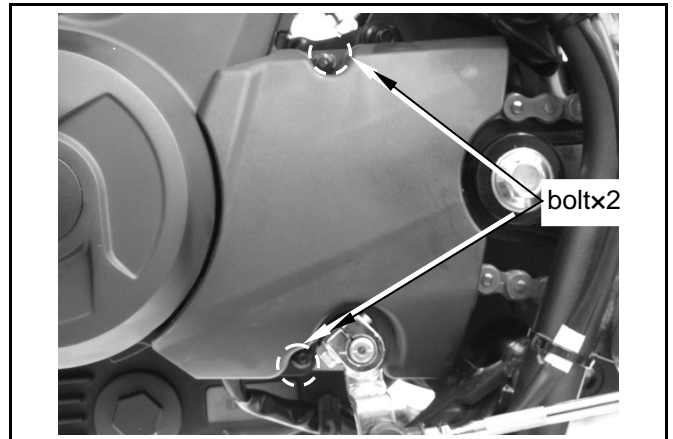

Remove the drive sprocket bolts (boltx2), sprocket fixing plate, and drive sprocket.

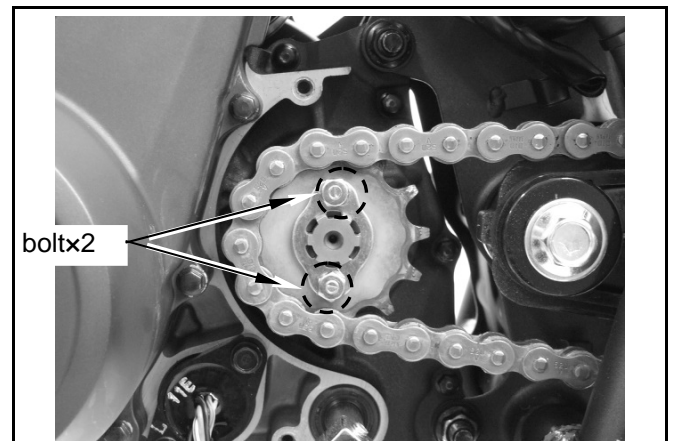

Remove the drive chain cover. (boltX2)。

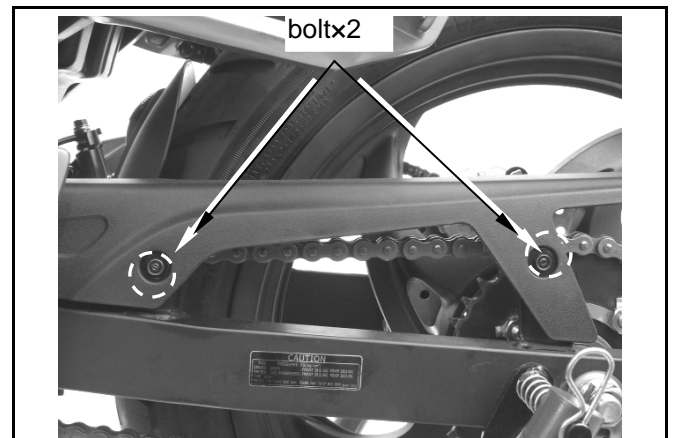

Remove the drive chain fixing clip and drive chain.

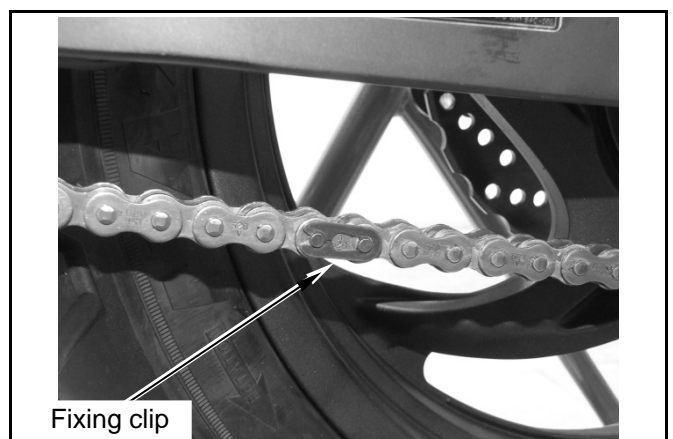

#### Drive chain / sprocket inspection

##### Sprocket

Check the condition of sprocket teeth.  
Replace the sprocket if the teeth are worn out.

##### Caution

- Sprocket and drive chain condition should be checked at the same time.

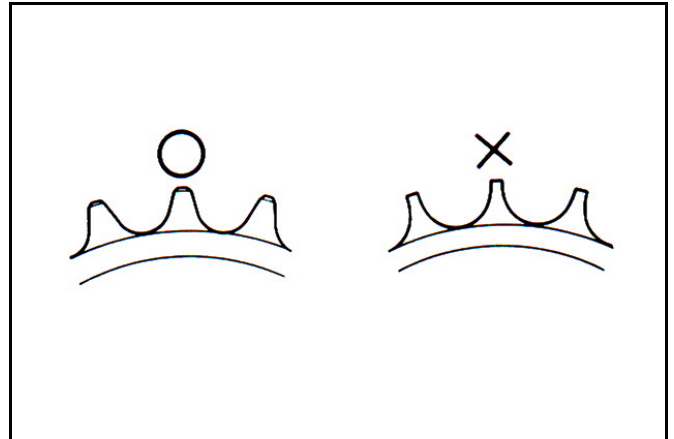

#### Drive chain

Clean and check the drive chain links condition. Replace the drive chain if it is worn out.

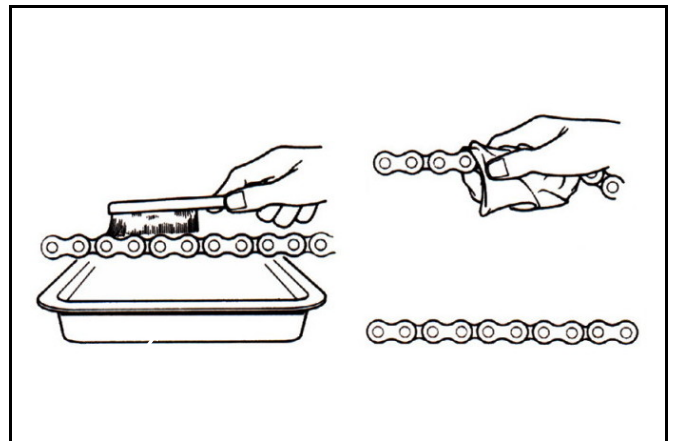

#### Sprocket / flange removal

Remove rear wheel / drive chain.  
Flat the sprocket bolt fixing washer.  
Remove sprocket nuts and fixing washer.  
Remove the sprocket.

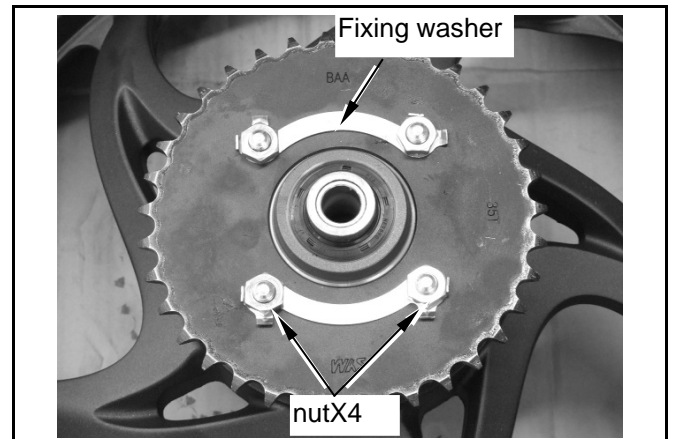

Remove the flange.



## 13. Rear wheel / Rear cushion



### Damper rubber inspection

Check if the damper rubbers worn or damaged, replace if necessary.

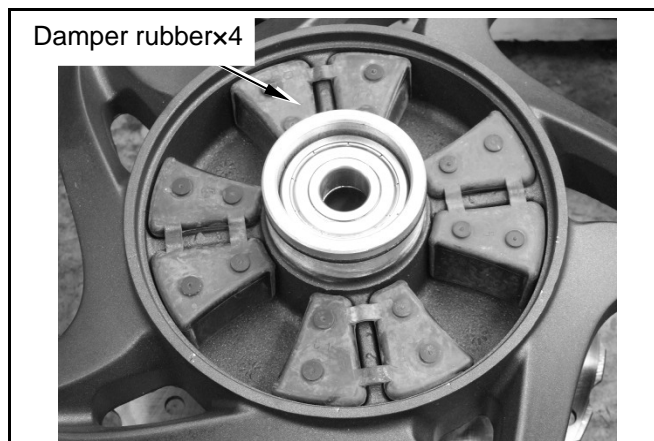

### Drive chain adjustment

Turn the left and the right side adjusting nut evenly to make the chain slack within the standard range.

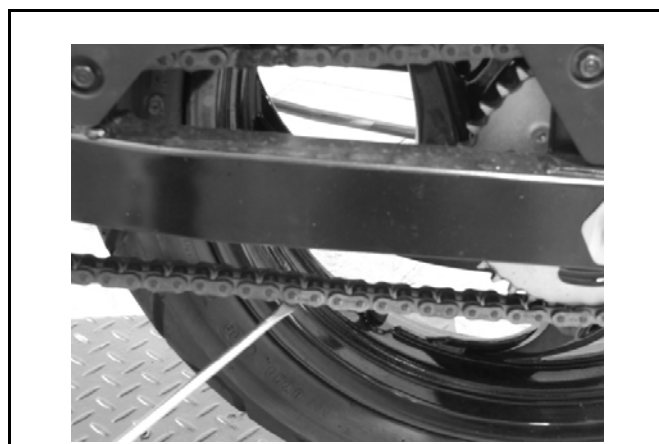

Turn the nuts clockwise to tighten the chain, or counterclockwise to loosen the chain.

**Chain slack: 10~20mm**

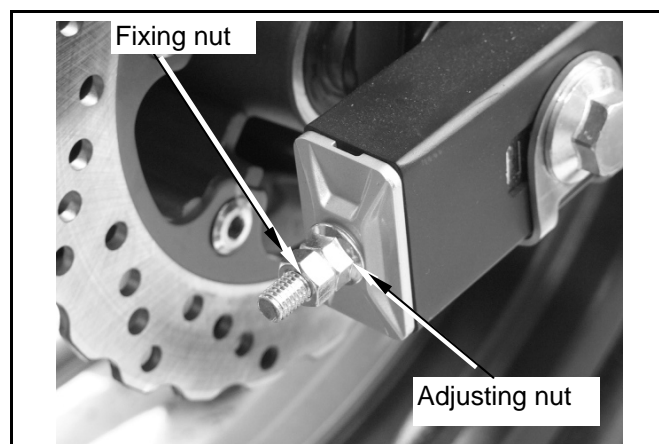

Tighten axle nut.

**Torque value: 10.0~12.0kgf-m**

After tightening the rear axle nut, please check the adjusting nuts to prevent them from loosening.

Recheck the chain slack, and make sure the rear wheel rotates smoothly.

Lubricate the chain with chain lubricant.

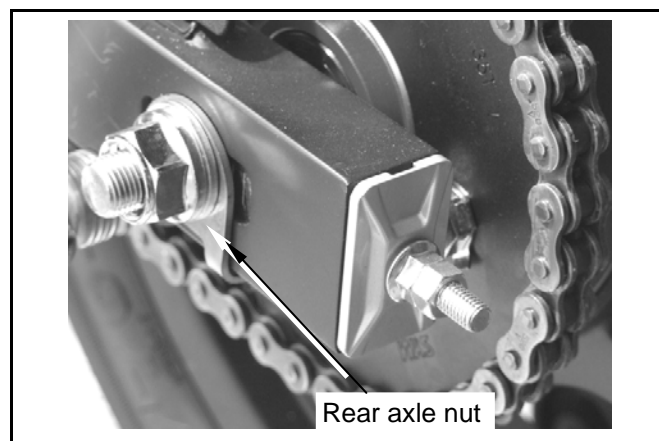



### Rear cushion

#### Removal

Remove the left body cover.

Remove the fuse / relay bracket. (bolt x2)

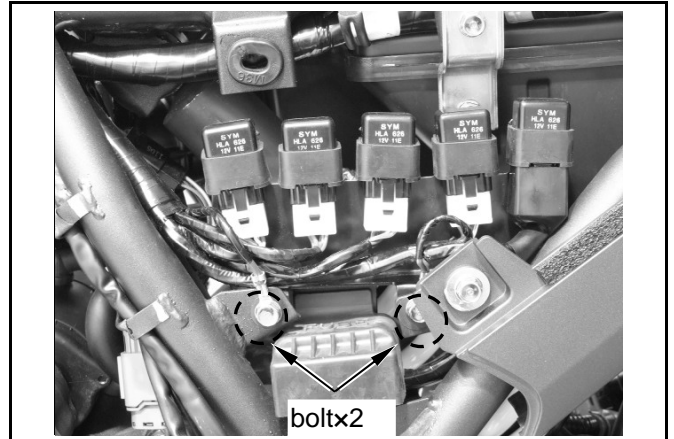

Remove the rear cushion upper bolt. (boltx1).

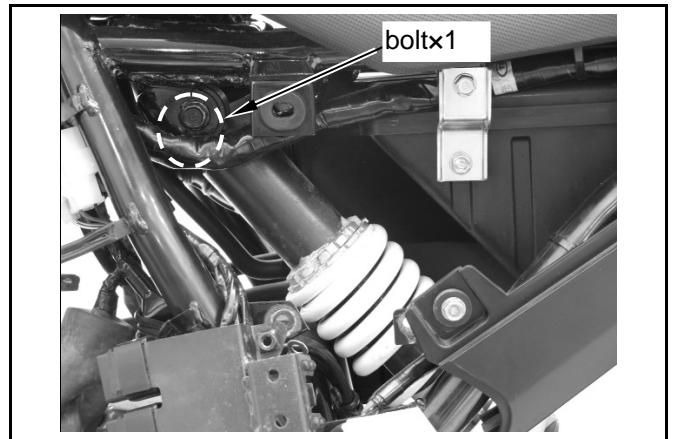

Remove the rear cushion lower bolt.  
Remove the rear cushion.

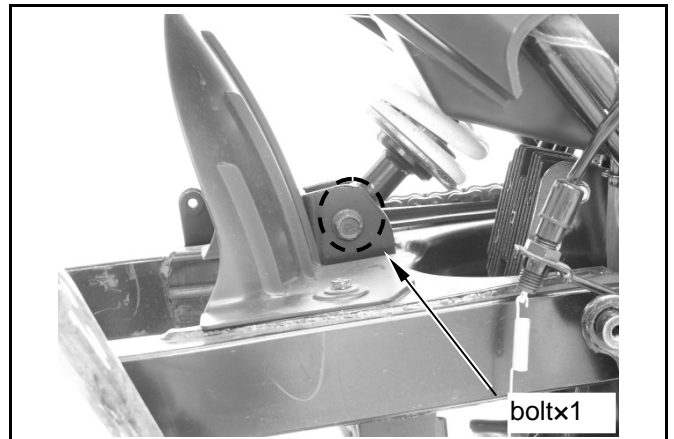

#### Installation

Install in the reverse order of removal.

**Torque value: cushion locknut 3.5~4.5kgf-m**

#### Caution

- The rear cushion should be replaced as a complete set. Do not disassemble it, or the structure and rubber bush will be damaged.

Press the rear cushion to check if the rear cushions move freely.

#### Special tool:

**Steering stem locknut socket wrench  
SYM-5320000**

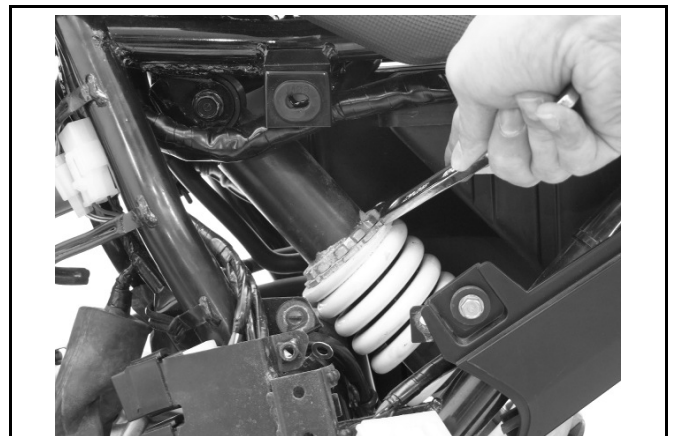

## 13. Rear wheel / Rear cushion



### Swingarm

#### Removal

Remove rear wheel, drive chain, sprocket, and rear cushion lower bolt.

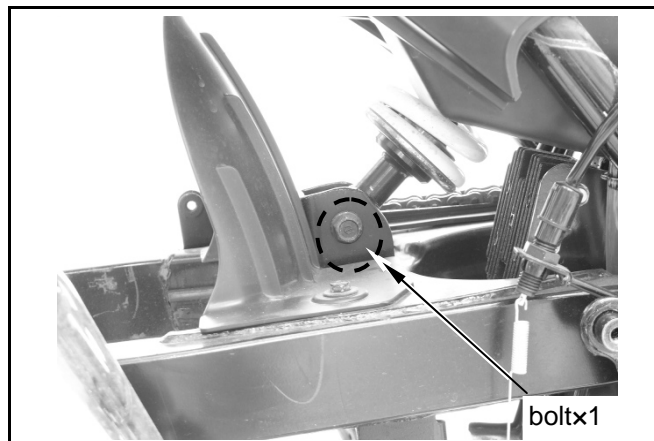

Remove the swingarm pivot locknut. (nutx1)。

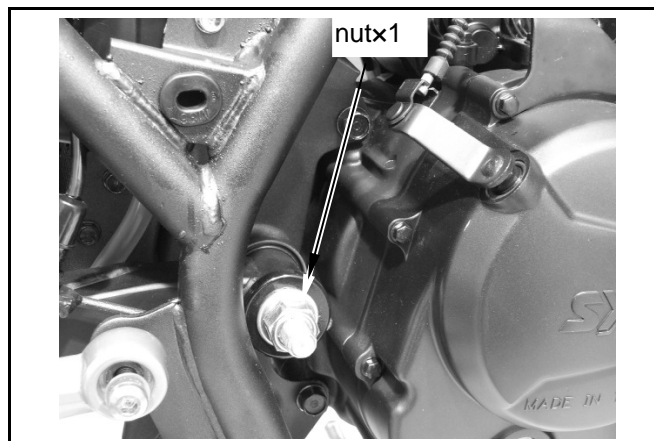

Pull out the swingarm pivot bolt.

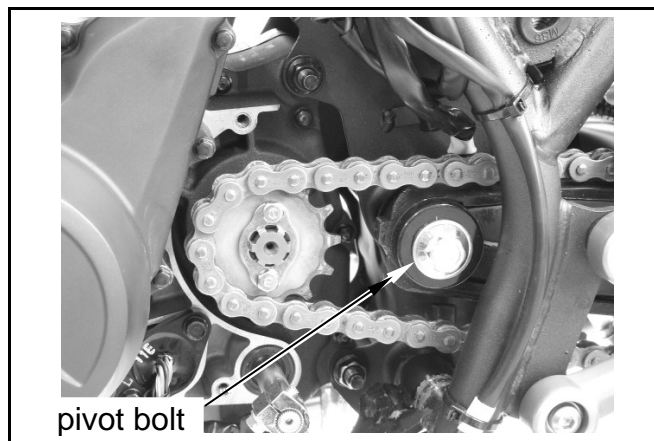

Remove the swingarm pivot sleeve and dust seal.

Remove the swingarm.

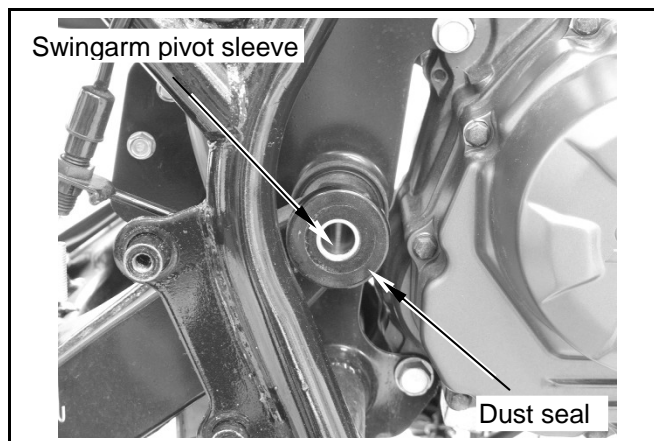

#### Inspection

Check if the swingarm worn or damaged.

Check if swingarm collars, sleeves and dust seals cracked or worn.

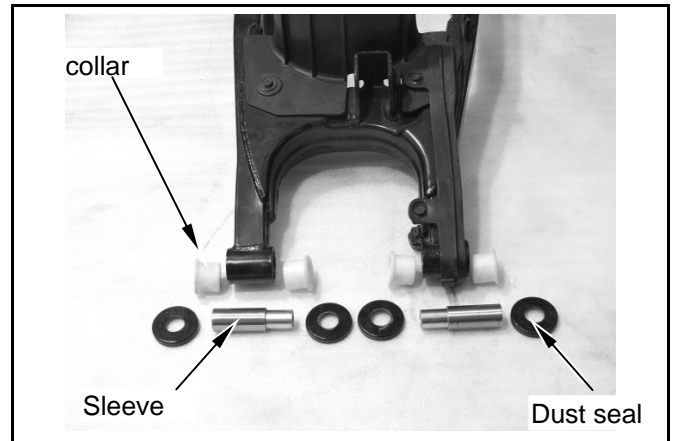

### Installation

Install in the reverse order of removal.

**Torque value: swingarm pivot locknut**  
**10.0~12.0kgf-m**

### Caution

- The rear cushion should be replaced as a complete set. Do not disassemble it, or the structure and rubber bush will be damaged.

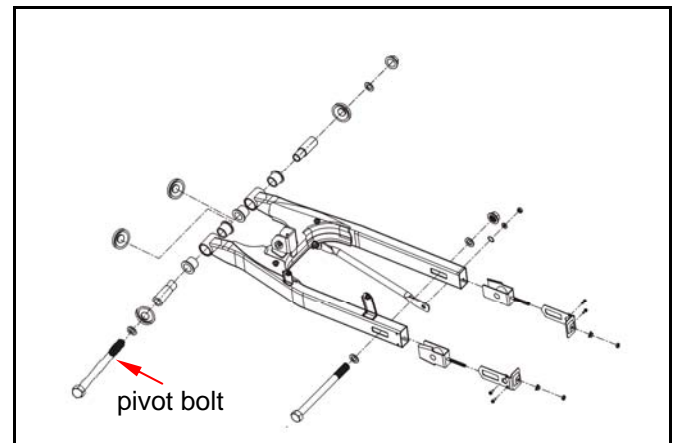

---

**NOTE:**

<b>Mechanism Diagram</b> .....	14-1	<b>Starting System</b> .....	14-13
<b>Precautions in Operation</b> .....	14-2	<b>Light system</b> .....	14-15
<b>Technical Specification</b> .....	14-3	<b>Meter</b> .....	14-16
<b>Troubleshooting</b> .....	14-4	<b>Light / Bulb</b> .....	14-17
<b>Fuse</b> .....	14-5	<b>Switch / Horn</b> .....	14-22
<b>Charging System</b> .....	14-6	<b>Fuel Unit</b> .....	14-26

## Mechanism diagram

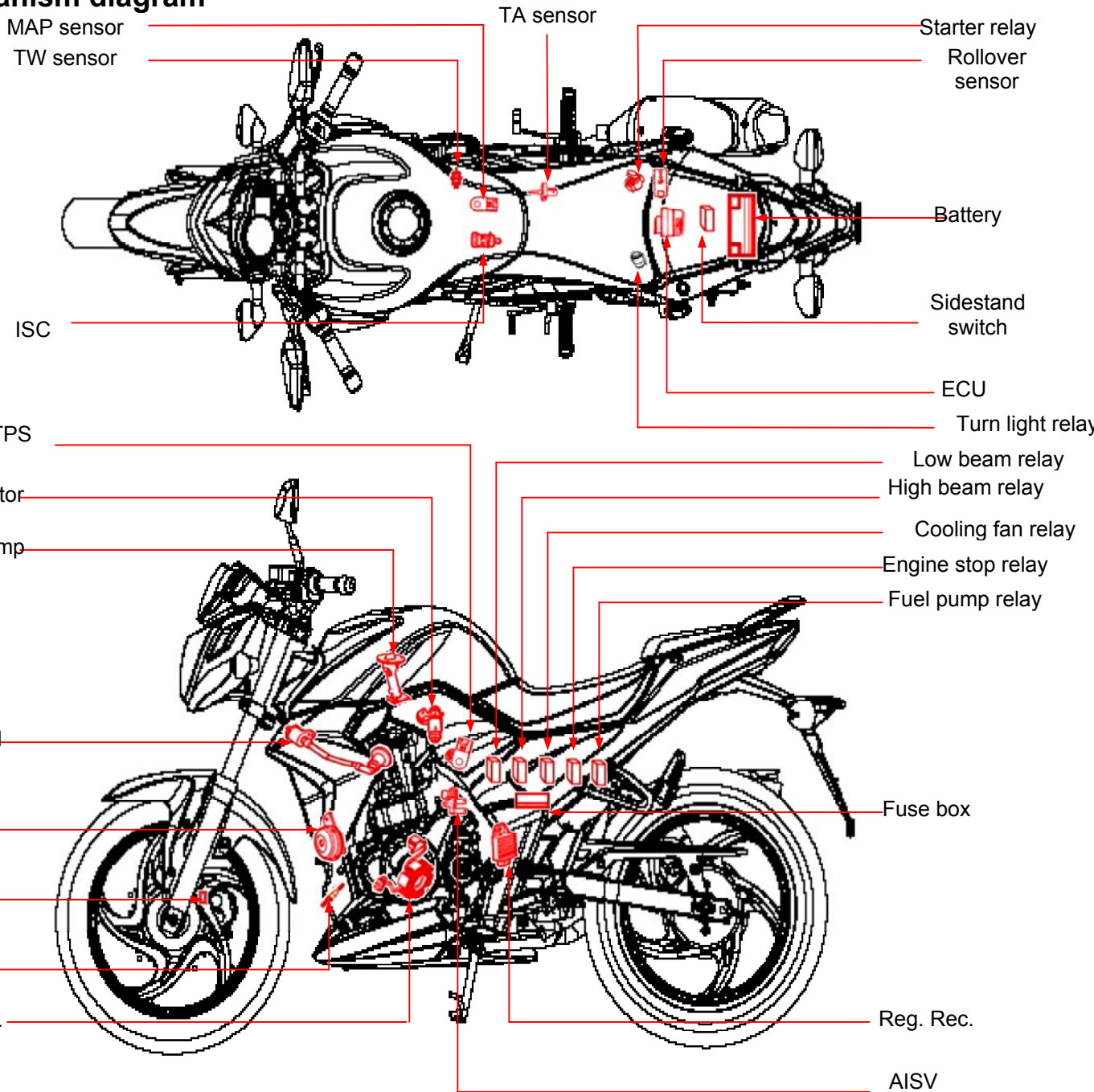

### Precautions in operation

#### Charging system

- When removing battery, first disconnect the negative cable terminal, then the positive cable terminal.
- The maintenance free battery requires no inspection of electrolyte level and refilling of distilled water.
- When charging, the battery has to be removed from the vehicle, but do not remove the sealing cap.
- Do not apply rapid recharge, unless it is an urgent situation.
- Use a digital voltmeter to check the charging voltage.
- The battery can repeatedly discharge and be recharged. After discharging, if the battery is not in use for a long time, deterioration, lowered efficiency, or shortened service life may occur to the battery. The battery efficiency will be lowered after 1~2 years in usual case. After recharging, the voltage of battery can be restored; If it connects to an additional load, the voltage will plunge then rise,
- Normal overcharging conditions can be observed from battery appearance. If battery inner circuit shorted, voltage cannot be measured at the battery terminals. If voltage regulator does not operate, the voltage will be too high and that may reduce battery's life.
- When not in use for a long time, the battery will self-discharge and the capacity decrease. Please recharge the battery around 2 months.
- After filling electrolyte, a new battery will generate a voltage of 12.5V or more after 10 minutes. If the voltage is still low, keep charging the battery. After fully charging a new battery, the service life of it will be prolonged.
- Please check electrical device according to the procedure of diagnosis chart.
- Do not disconnect and connect the connector of electrical devices when current is passing these devices because this will generate high voltage and the electrical components in the voltage-current regulator will be damaged. The ignition switch must be turned OFF before performing any work.
- Please do not replace with a traditional type battery as replacement.
- Please refer to the removal instruction when removing ACG and CPS.

#### Ignition System

- Please follow the procedure of trouble diagnosis chart to check ignition system.
- As E.C.U. transistor ignition assembly does not require an ignition timing check. In case ignition timing is incorrect, check E.C.U. and AC generator. Verify with an ignition timing light after replacement if necessary.
- E.C.U. failure reasons are most resulted from E.C.U. looseness or impact. Take special care when removing.
- Most of ignition system problems were resulted from poor connecting connector. Please check the connectors first when servicing.
- Make sure that the heat range of spark plug is suitable. Improper spark plug is the main cause of poor engine operation or combustion.
- Inspection procedures in this manual are based on Max. voltage. This manual also contains methods of how to check ignition coil resistance and component operation.
- Please follow the continuity chart to check ignition switch.

#### Starting system

- Please follow the inspection procedures of troubleshooting to check ignition system.
- Starting motor can be removed directly from engine.
- Please refer to chapter 5 for starting clutch removal procedures.

## Technical specification

### Charging system

Item		Specification
Battery	Capacity / Model	12V 10Ah GT12A-BS
	Charging rate	Standard:1.2A / 5~10hr Rapid:5A / 1hr
	Fully charged	voltage(20°C)
	Need to be charged	
ACG	Output	14.5~28A
	Charging circuit resistance (20°C)	0.42Ω±20% (Y/Y)
Leaking current		Under 10mA
Start charging R.P.M.		Under 2100 rpm
Voltage controlled by regulator		14.5±0.5 V
Fuse	Others	15A
	Battery	20A
	Main switch	15A
	Injection system	10A

### Ignition system

Item		Specification
Spark plug	Model	NGK CR8E
	Gap	0.7~0.8 mm
Ignition coil resistance	Primary	2.8Ω±15%
	Secondary	Without plug cap: 9.0KΩ±20% With plug cap : 14.0KΩ±20%
CPS resistance		120Ω±20%

### Starting system

Item		Specification
Starting motor	Model	DC type
	Output	0.6 KW

### Troubleshooting

#### Charging system

##### No power supply

- Disconnected battery cable
- Battery over discharging
- The fuse is blown
- Improper operation of the main switch

##### Low voltage

- The battery is not fully charged
- Poor contact
- Poor charging system
- Poor regulator rectifier

##### Intermittent power supply

- Loosened charging system connector
- Poor battery cable connection
- Poor connection or short-circuit of the charging system
- Poor connection or short-circuit of the power generation system

##### Faulty charging system

- The fuse is blown
- Connector poor contact, short, or open
- Poor regulator rectifier
- Poor ACG

#### Starting system

##### Starter motor does not work

- The fuse is blown
- The battery is not fully charged
- Poor main switch
- Poor starter switch
- The front or rear brake switches do not operate correctly
- Starter relay is out of work
- The ignition coil is poorly connected, open or short-circuited
- The starter motor is out of work

#### Ignition system

##### No spark

- Poor spark plug
- The cable is poorly connected, open or short-circuited
  - Between ACG and ECU
  - Between ignition coil and ECU
  - Between main switch and ECU
- Poor main switch and relay
- Faulty ECU
- Faulty ACG

##### Engine does not crank smoothly

- Primary coil circuit
  - Poor ignition coil
  - Cables, wire, ,connector poor contact
  - Main switch poor contact
- Ignition circuit
  - Poor ignition coil
  - Poor spark plug
  - Faulty ignition coil wire
  - Current leakage in the spark plug cap
- Incorrect ignition timing
  - Faulty ACG
  - Improper installation of CPS
  - Faulty ECU

##### Weak starter motor

- Poor charging system
- The battery is not fully charged
- Poor connection in the windings
- The motor gear is jammed by foreign material

##### Starter motor is working, but engine does not crank

- Poor starter motor pinion
- Poor starter clutch
- The starter motor run in reverse direction
- Poor battery



## Fuse

### Fuse circuit

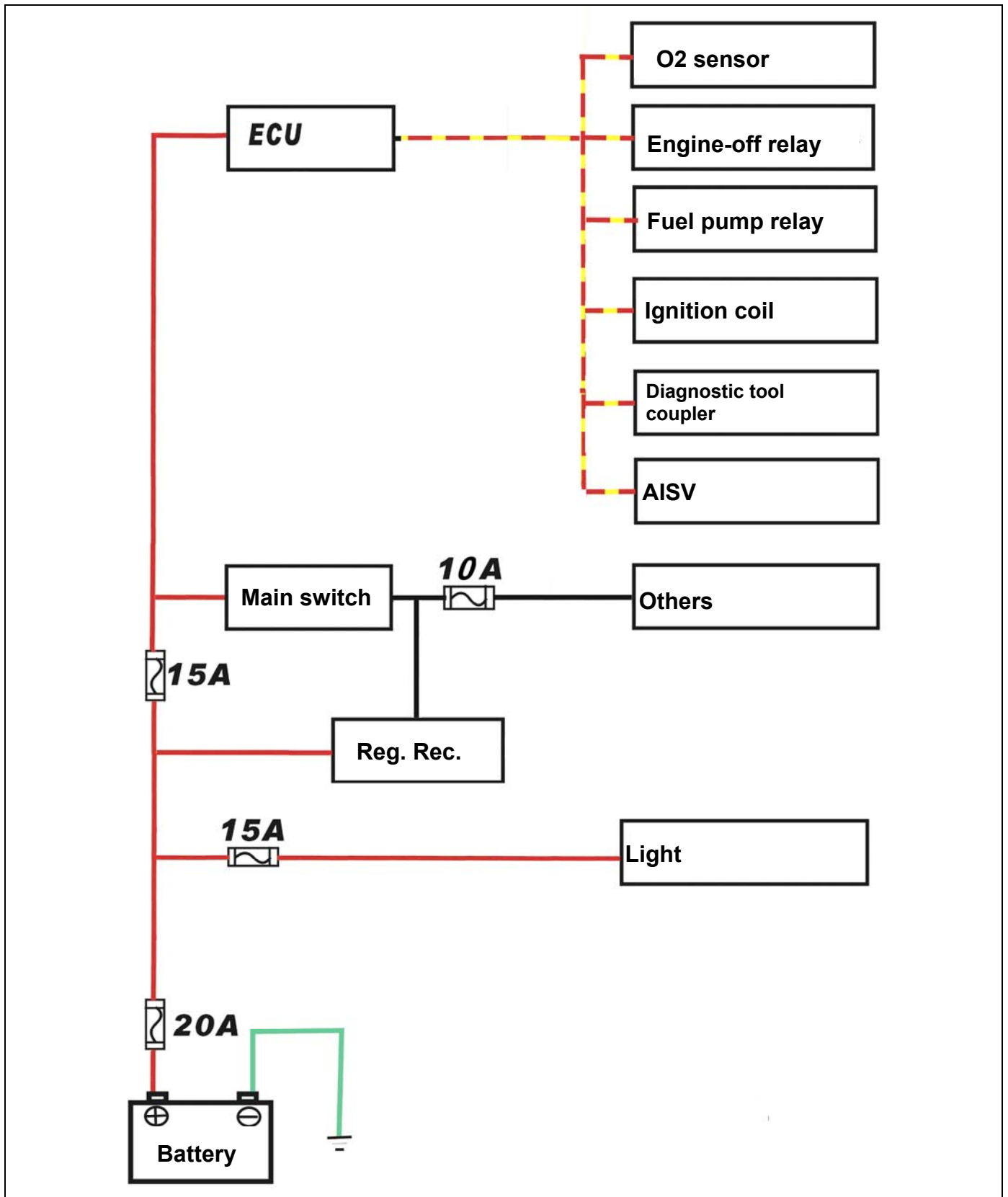

## 14. Electrical system



### Charging system

#### Battery removal

Remove the rear seat.



- Electrolyte (diluted sulfuric acid) is very toxic. Once it spread on clothes, skin, or eyes, it will cause burn. In case of being spread, flush with great quantity of water immediately, and then send to hospital.
- Once clothes are spread by electrolyte, it will contact with skin. Immediately take off the clothes and flush with great quantity of water.

Disconnect the negative terminal wire first and then the positive terminal.

Remove the battery.

#### Battery installation

Install in the reverse order of removal.



- To prevent short circuit, the positive terminal wire should be connected before the negative terminal being connected.

#### Current leakage inspection

Key off and disconnect the ground cable (negative) from the battery.

Connect the ammeter (+) probe to the ground cable and the ammeter (-) probe to the negative terminal of the battery.



#### Caution

- When measuring the current, set the ammeter to a higher range and then set the range down to the appropriate level. Current flow higher than the selected range may blow out the fuse in the ammeter.
- While measuring the current, do not key on or a sudden surge of current may blow out the fuse in the ammeter.

If the current leakage exceeds the specified value, a shorted circuit may occur.

#### Current leakage : below 10mA

Locate the shorted circuit by disconnecting the connections one by one and measuring the current.

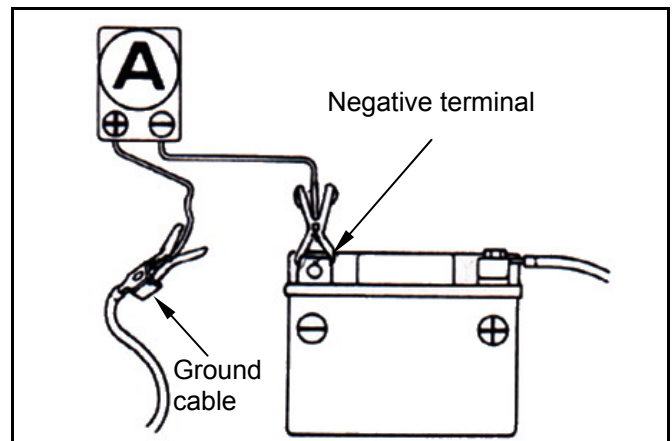
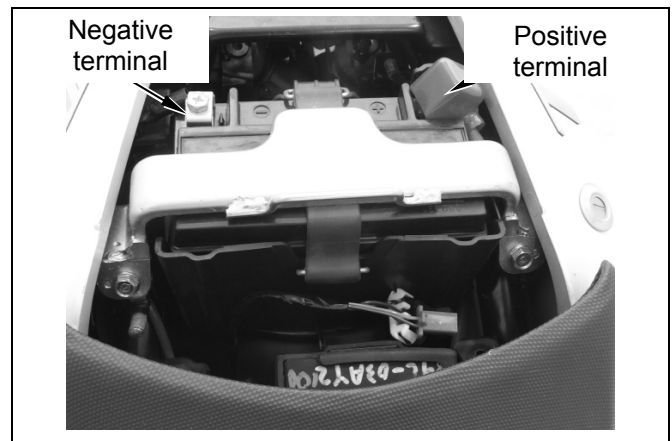
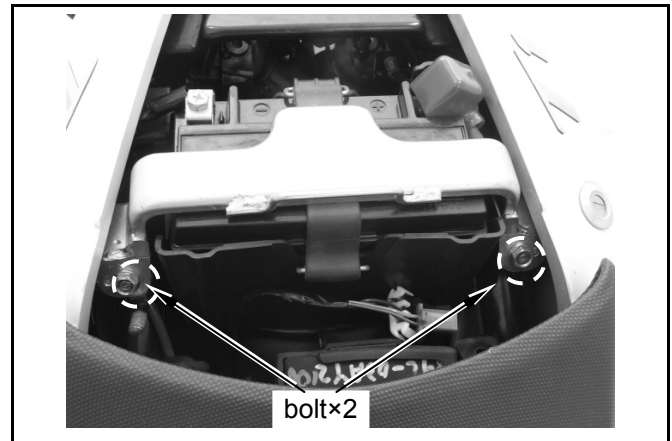

### Voltage inspection

Measure the battery voltage by using a digital multimeter.

### Voltage

Fully charged: 14.0~15.0V (20°C)

Insufficiently charged: 12.3V (20°C)

### Charging

Remove the battery cell caps.

Connect the charger positive (+) cable to the battery positive (+) terminal.

Connect the charger negative (-) cable to the battery negative (-) terminal.

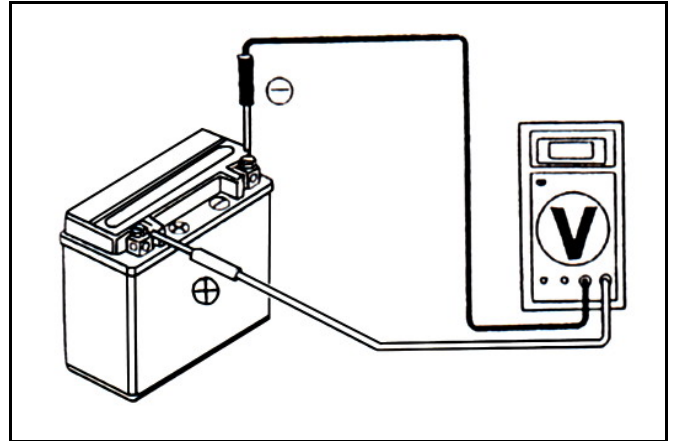

### ⚠ Warning

- Avoid any fire near the battery during charging.
- Control the charging from ON/OFF on the charger, do not disconnect the cables.
- Before or after charging, always turn off the charging machine to avoid explosion caused by sparks.
- Follow the regulated charging current and time shown on the battery.

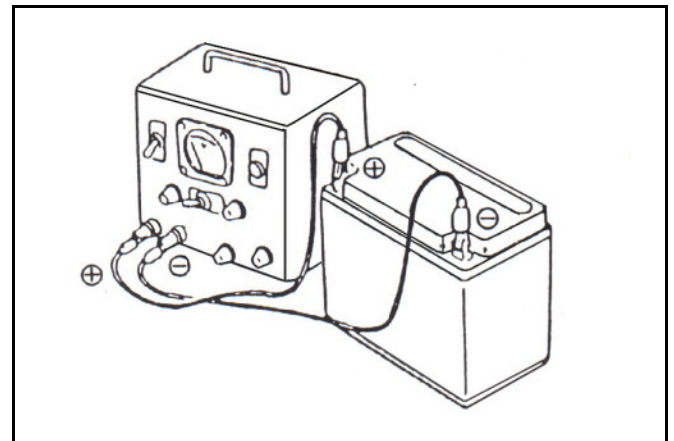

### ⚠ Caution

- Do not charge the battery quickly except for emergency situation.
- Confirm the charging current and time before charging the battery.
- Excessive charging current or time will damage the battery.
- After charging the battery, wait for 30 minutes and then measure the battery voltage.

After installing the battery, coat the terminal with grease to avoid oxidation.

## Inspection on Charging Voltage / Current

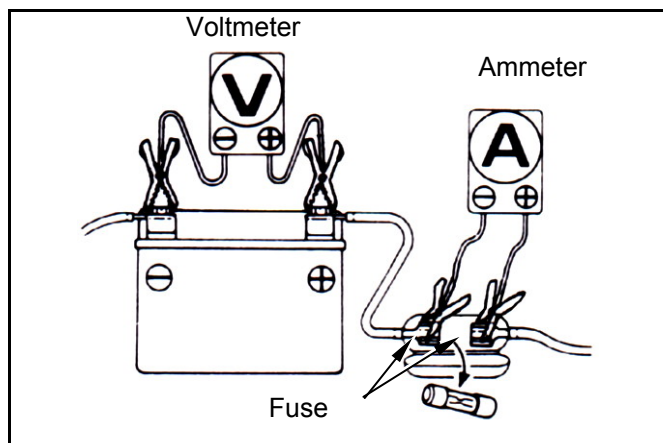

### ⚠ Caution

- Before conducting the inspection, be sure that the battery is fully charged with a voltage larger than 13.0 V. If undercharged, the current changes dramatically.
- While starting the engine, the starter motor draws large amount of current from the battery.

After the engine is warmed up, replace original battery with a fully charged battery.

Connect a digital voltmeter to the battery terminals.

Connect an ammeter between both ends of the main fuse.

### ⚠ Caution

- When the probe is reversibly connected, use a voltmeter having an indication that the current flows from the positive or the negative direction and the measurement should be at zero, ammeter at one direction only.

### ⚠ Caution

- Do not use a short-circuit cable.
- It is possible to measure the current by connecting an ammeter between the battery positive terminal and the cable position terminal, however, while the starter motor is activated, the surge current the motor draws from the battery may damage the ammeter. Use the kick starter to start the engine.
- The main switch shall be turned to OFF position during the process of inspection. Never tamper with the ammeter and the cable while there is current flowing through. It may damage the ammeter.

Connect a tachometer.

Turn on the headlight to high beam and start the engine.

Accelerate the engine to the specified revolution per minute and measure the charging voltage.

**Charging Current: 0.6A / 2100rpm (headlight off)  
1.2A / 6000rpm**

**Control Charging Voltage: 14.5±0.5V/2100rpm**

### ⚠ Caution

- To replace the old battery, use a new battery with the same current and voltage.

The following problems are related to the charging system; follow the instructions provided in the checking list to correct it if any of the problems takes place.

- ①. The charging voltage can not exceed the voltage between two battery terminals and the charging current is in the discharging direction.
- ②. The charging voltage and current are much higher than the standard values.

The following problems are not related to the charging system; correct it if any by following steps indicate in the checking list.

- ①. The standard charging voltage and current can only reach when the revolution of the engine exceeds the specified rpm.
  - Bulbs used exceed their rate and consume too much power.
  - The replacement battery is aged and does not have enough capacity.
- ②. The charging voltage is normal, but the current is not.
  - The replacement battery is aged and does not have enough capacity.
  - Battery used does not have enough electricity or is over charged.
  - The fuse of the ammeter is blown.
  - The ammeter is improperly connected.
- ③. The charging current is normal, but the voltage is not.
  - The fuse of the voltmeter is blown.

## Charging circuit

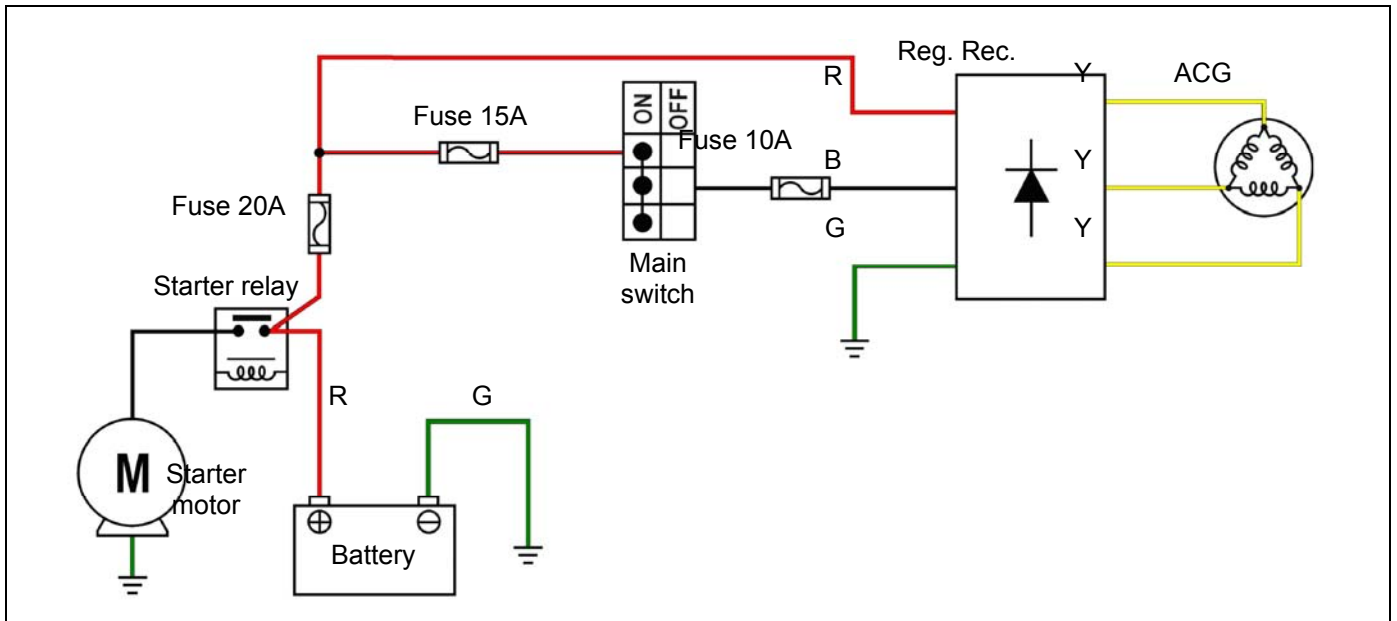

## Regulator/ rectifier inspection

(KΩ)

	+	Y1	Y2	Y3	R	B	G
-							
Y1			∞	∞	∞	∞	∞
Y2		∞		∞	∞	∞	∞
Y3		∞	∞		∞	∞	∞
R		∞	∞	∞		∞	∞
B		5~30	5~30	5~30	∞		1~10
G		2~20	2~20	2~20	∞	1~10	

## AC Generator

Remove wire strap right-up side cover.  
Disconnect the ACG coupler 3P coupler.

Disconnect the regulator rectifier 6 pin coupler and inspect the wire circuit.

Item	Wire color	Judgment
Main switch	R- B	Battery voltage (ON)
Battery	R- G	Battery voltage
Charge coil	Y- Y	$0.42\Omega \pm 20\%$

If the readings measured are not normal, check parts in the circuit.

If the parts are normal, then trouble is in the wiring.

If there is nothing wrong with parts and wiring, replace the regulator rectifier.

## ACG coil inspection

Disconnect 3 pin couplers of the generator coil. Connect an ohmmeter to the each terminal end.

Check the continuity of the each terminal end, and engine ground with short circuit?

If there is no continuity or short circuit, replace the AC. Generator.

	V	$\Omega$
Y1	70~80	$0.42\Omega \pm 20\%$
Y2	70~80	$0.42\Omega \pm 20\%$
Y3	70~80	$0.42\Omega \pm 20\%$

Without disconnecting the coupler, voltage generated can also be checked by voltmeter while the engine is running.

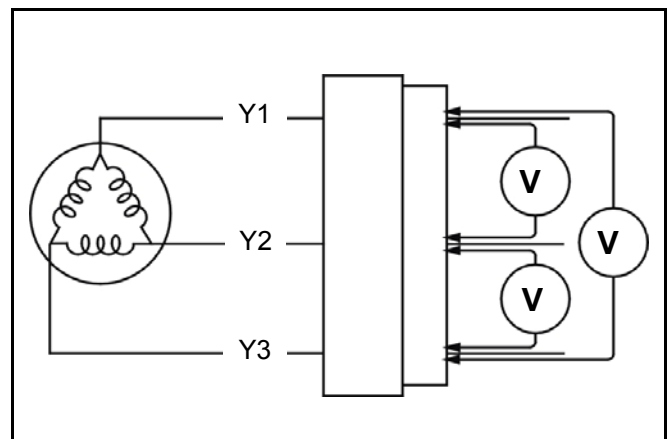
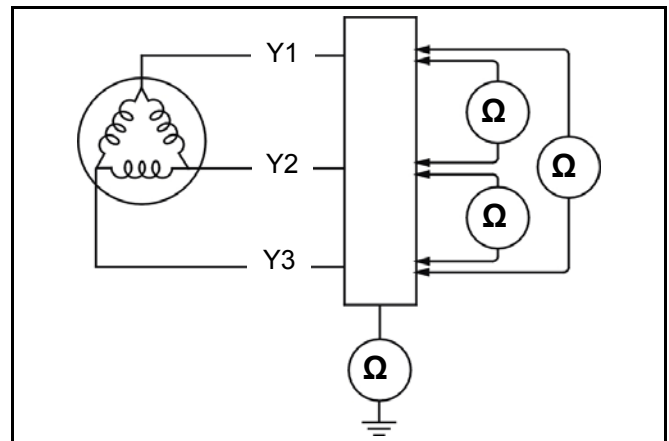
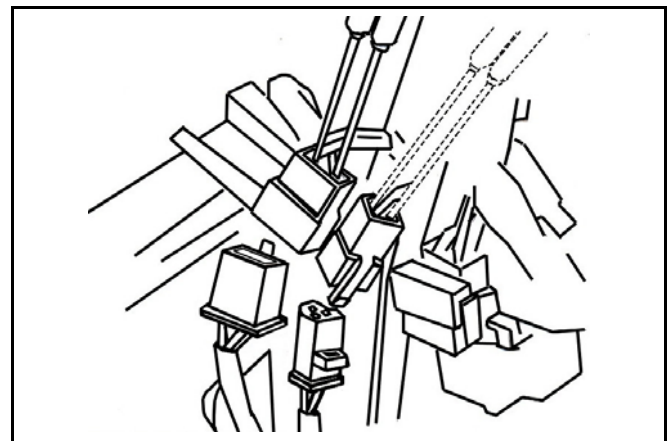
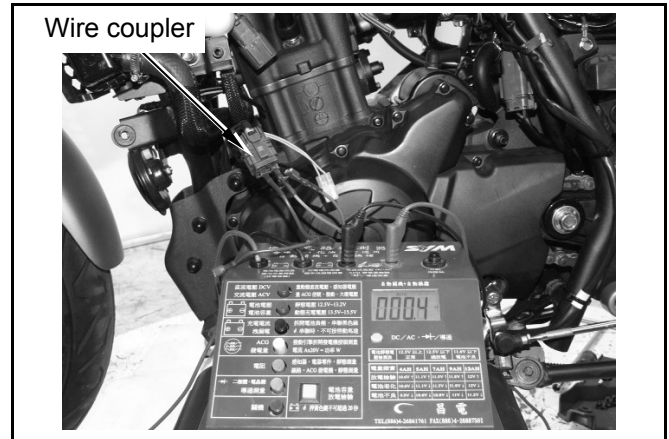

### Ignition coil

#### Removal

Remove side cover and seat.  
Remove spark plug cap.  
Remove ignition coil wire.  
Remove bolts and ignition coil.  
Install in the reverse order of removal.

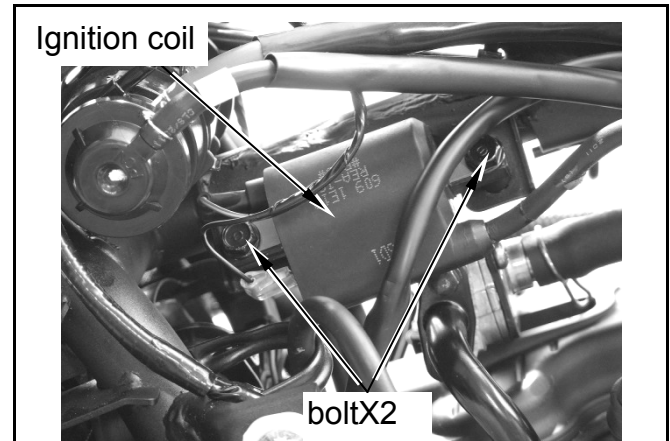

### Spark plug confirmation

Remove the spark plug and install a good plug into plug cap, and then ground it to engine ground. Check its spark condition. If it is in not good or burnt spark plug, replace the spark plug with a new one.



- Make sure each wire connection is correct, and test as required. Even the wire connection is correct; sometimes the test may not be carried out successfully.

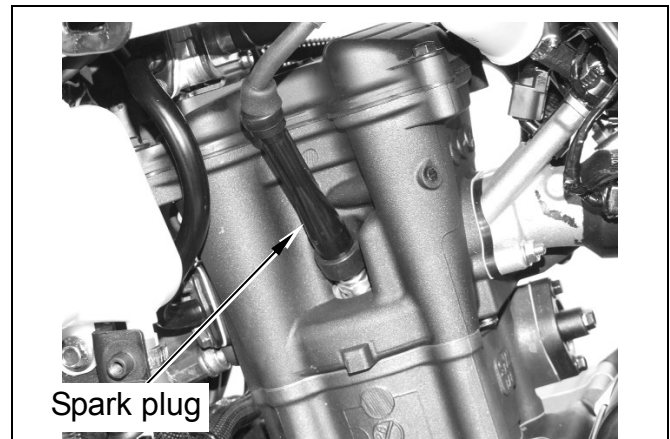

Connect the high voltage shunt with a multi-meter or input a resistor in the 10M 10CV of voltage meter.

Measure voltage and resistance.

#### Voltage: battery voltage



- Do not touch metal parts on the test probe with fingers to avoid electric shock.

注意

## Ignition circuit

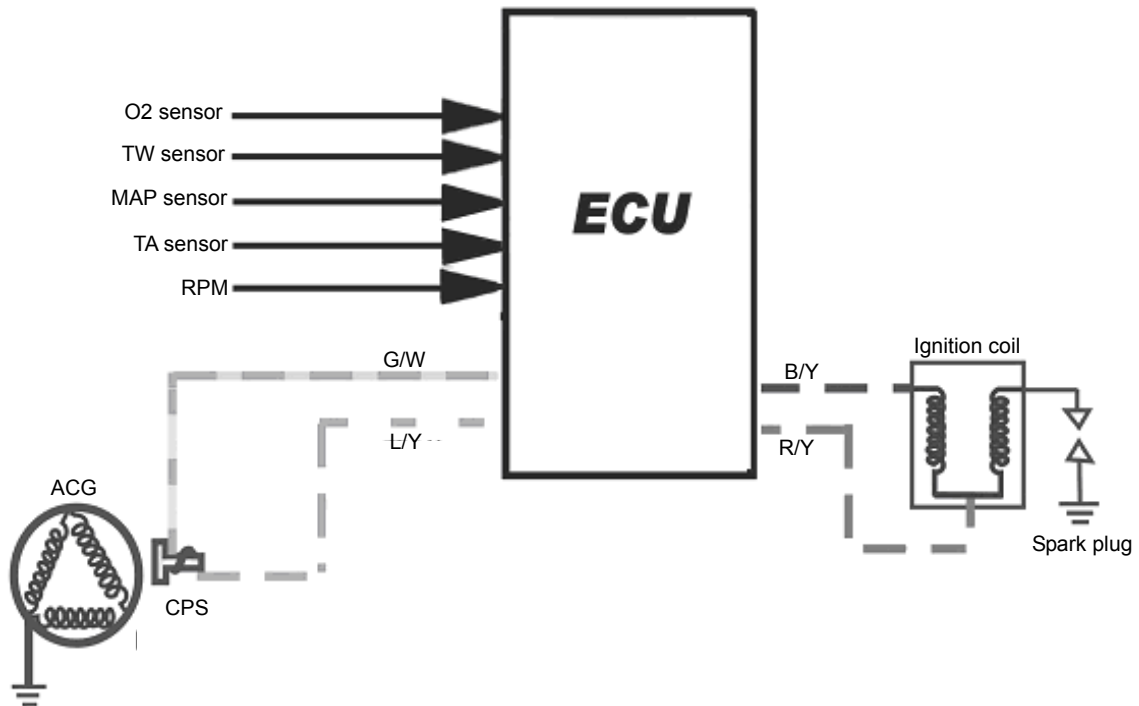

## Ignition coil inspection

Remove ignition coil connector.  
Measure the resistance of ignition coil.

**Standard value:**

Primary:  $2.8\Omega \pm 15\%$

Secondary: Without plug cap:  $9.0K\Omega \pm 20\%$

With plug cap:  $14.0K\Omega \pm 20\%$

## CP Sensor inspection

Remove wire strap.

Disconnect CP Sensor 2P coupler, measure the resistance between the terminals of green/white and blue/yellow.

**Standard value:**  $120\Omega \pm 20\%$

**⚠ Caution**

- No need to remove circuit from the engine to carry out this test.

Please refer to ch. 5 if the circuit needs to be replaced.

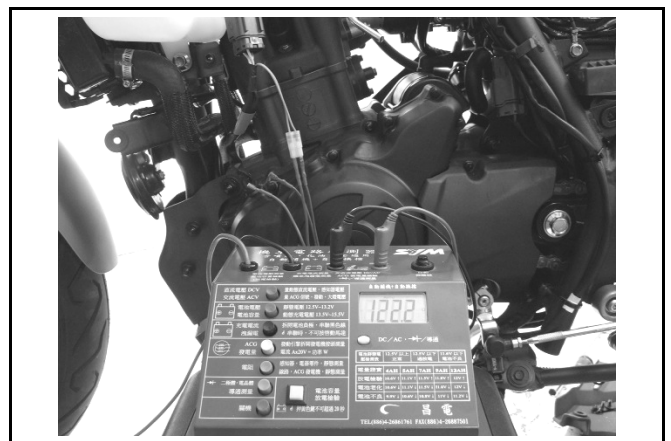
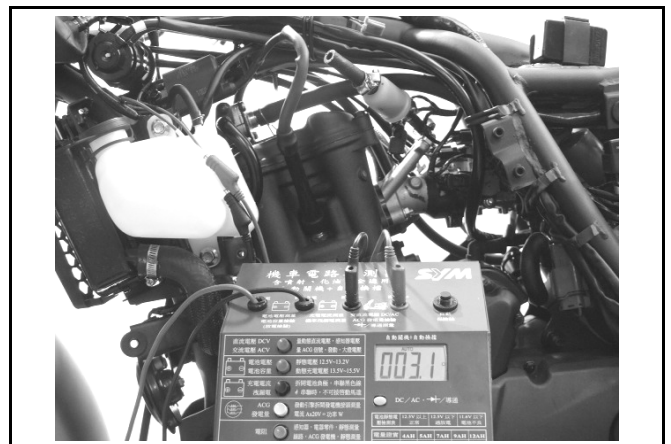



## Starting system

### Starting circuit diagram

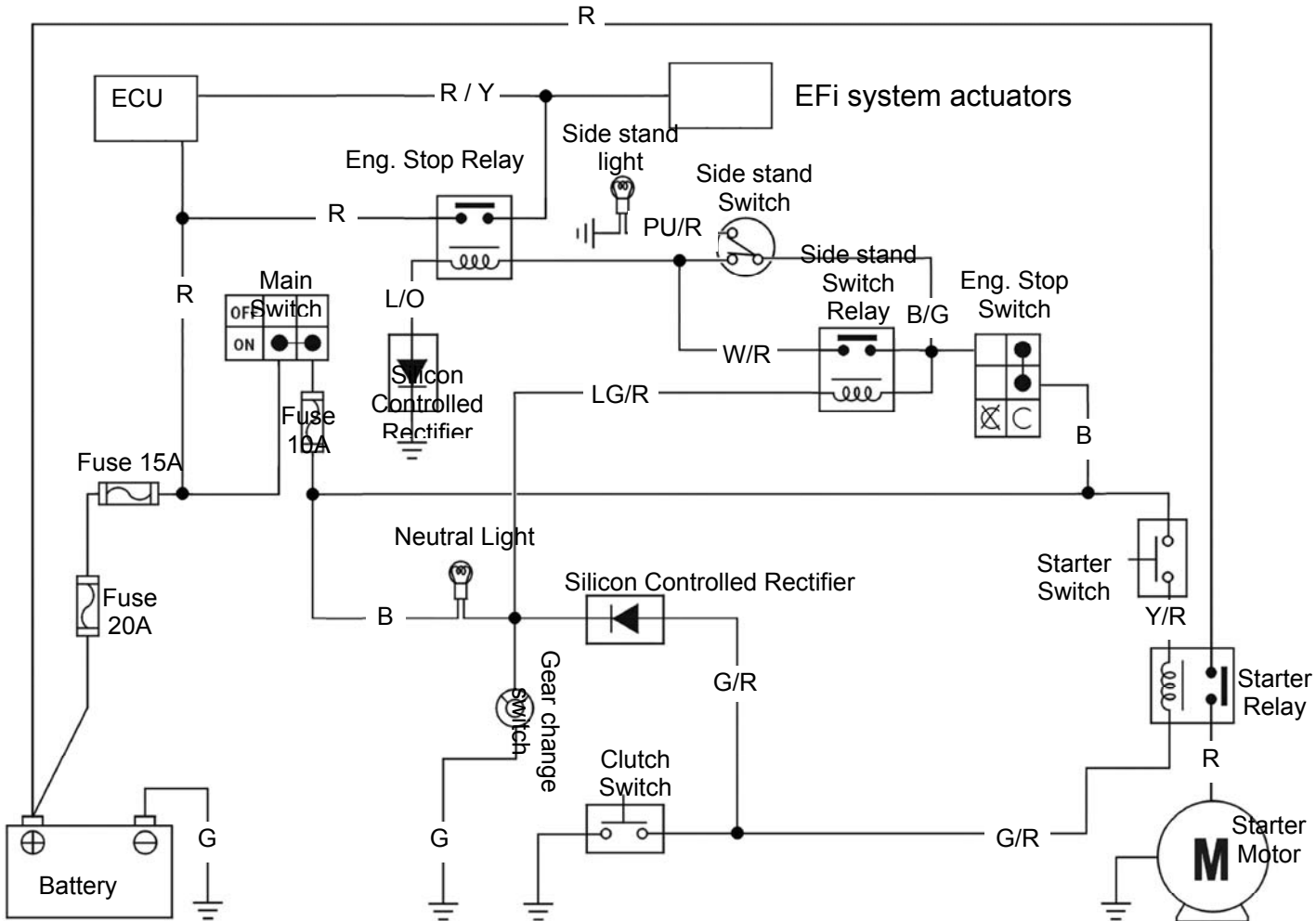

### Starter relay inspection

Key on and pull the brake lever and press the starter switch.  
If a sound of “Looh Looh” is heard, it indicates the relay function normally.

Disconnect the negative terminal wire.  
Disconnect the starter relay coupler.  
Connect an ohmmeter to the starter relay terminal.  
Connect the green / yellow wire to the battery positive terminal and the yellow / red wire to the battery negative terminal.  
Check the continuity of the starter relay terminal.  
If there is no continuity, replace the relay.

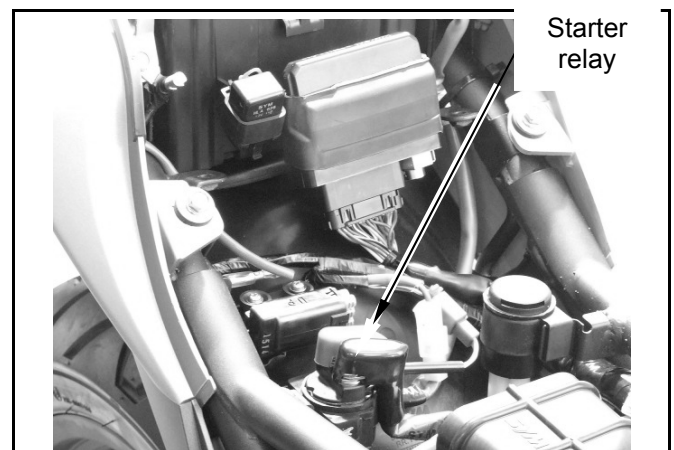

## 14. Electrical system



### Starter motor removal

Remove the starter motor wire. (nut×1)  
Remove the starter motor. (bolt×2)

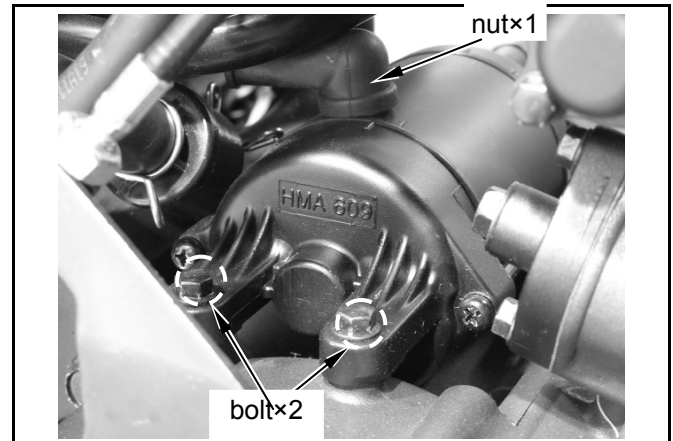

### Starter motor inspection

Connect the battery positive terminal and starter motor power terminal.  
Put up iron between the battery negative terminal and starter motor case.  
Check the starter motor rotating condition.  
Replace the starter motor if the rotating speed is too slow.

### Starter motor installation

Install in the reverse order of removal.



- Make sure the O ring is ok and coat it with motor oil before installation.

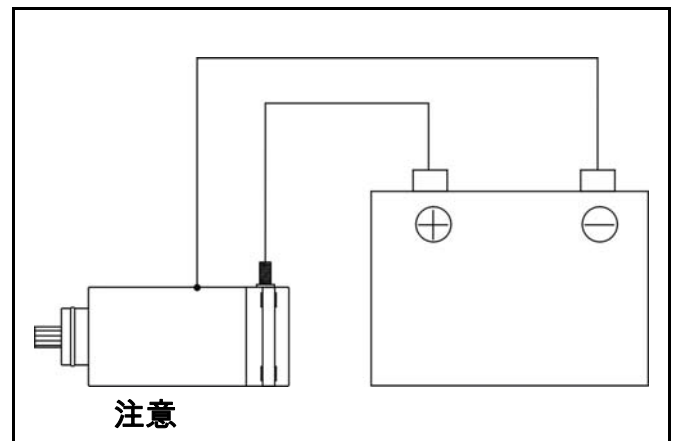

## Light system Light circuit

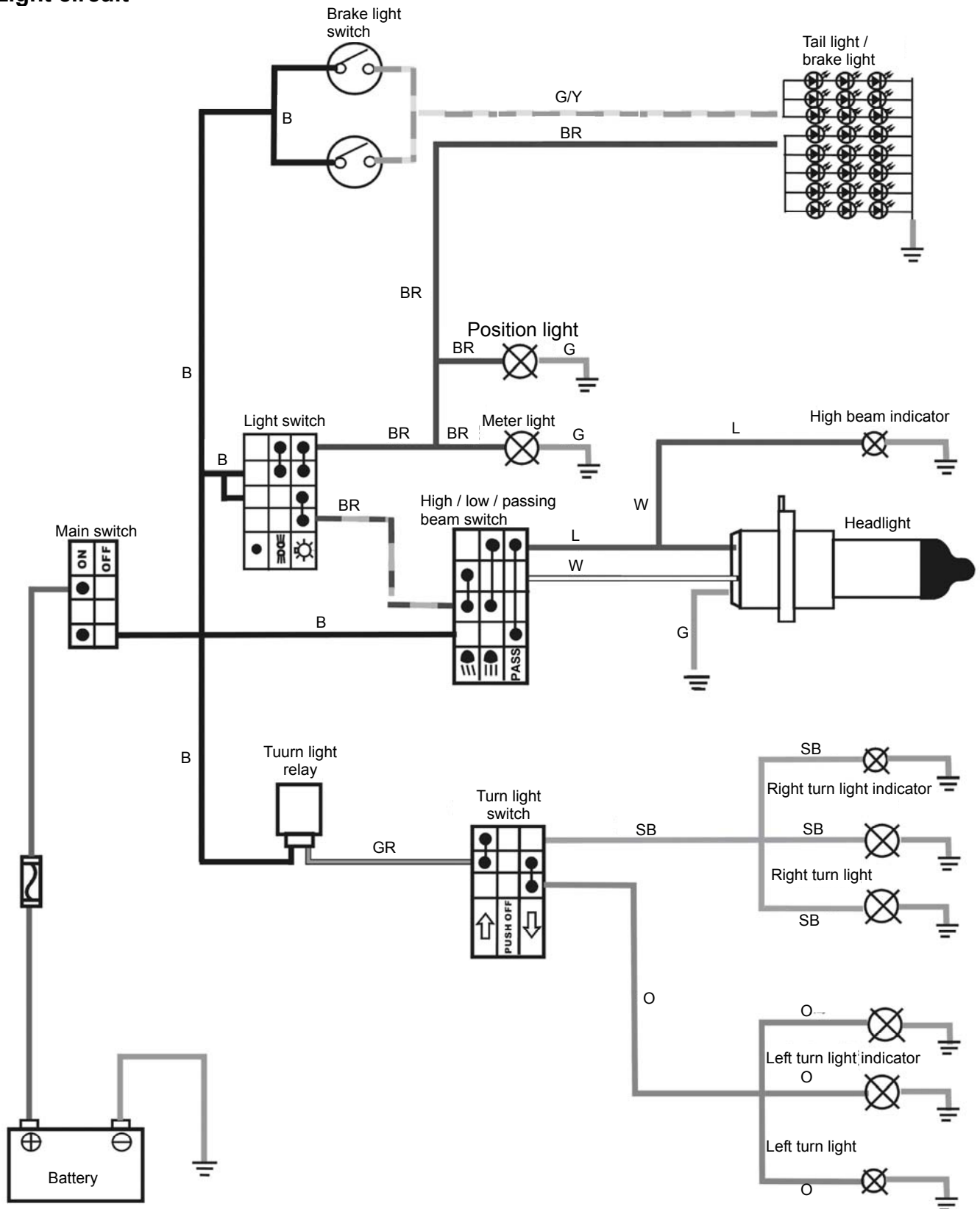

## 14. Electrical system



### Meter

#### Removal

Remove the headlight / meter (bolt x2).

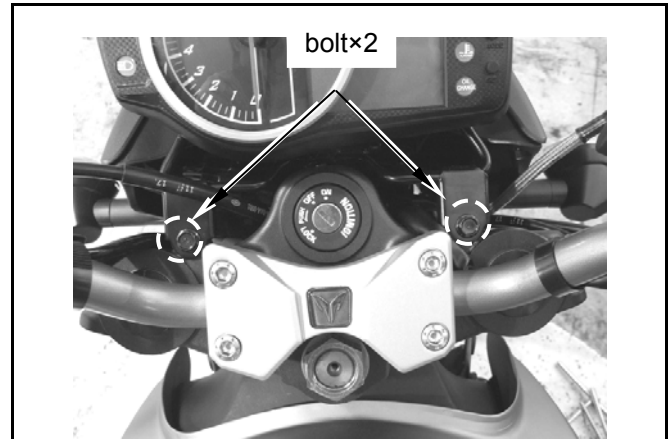

Disconnect the headlight / meter coupler.

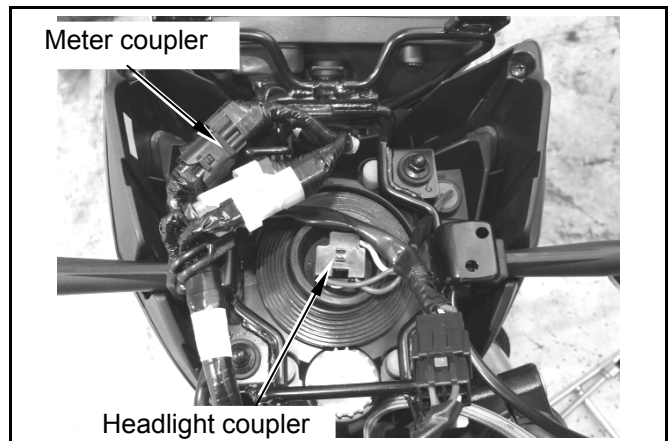

Remove the headlight locknuts. (nut x4)

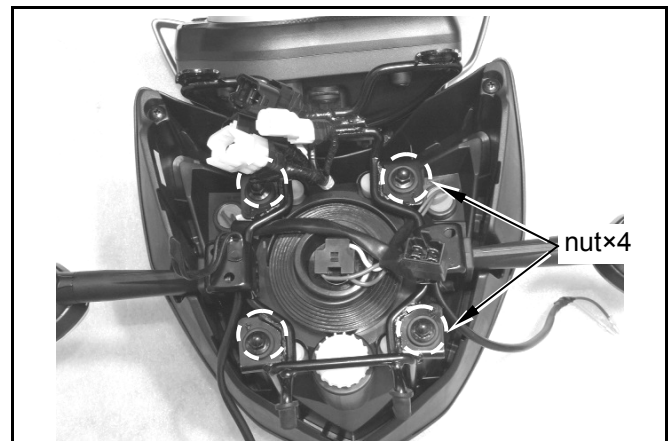

Remove the meter locknuts. (nut x3)  
Remove the meter.

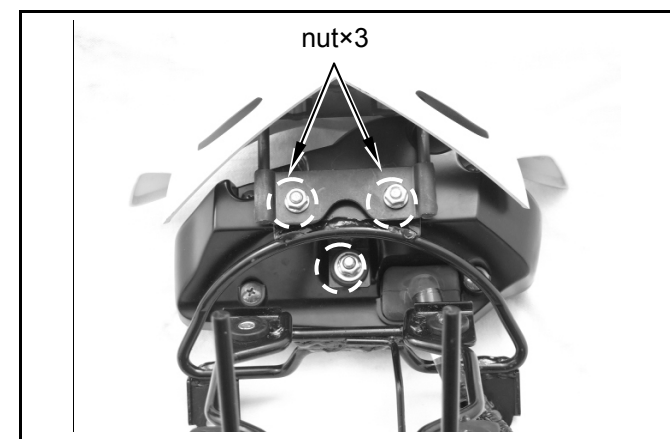

#### Installation

Install in the reverse order of removal.

## Light / Bulb

### Headlight bulb replacement

Remove the headlight / meter. (boltX2)

Disconnect the headlight coupler.  
 Remove the rubber protector.  
 Push down the bulb fixing spring and remove the bulb.  
 Replace with a new bulb if necessary (12V 55W/60W)。

#### Caution

- Never touch the bulb with bare fingers, which may create a heat point and lead to premature bulb failure. Wear gloves or cover with cloth.
- Clean the fingerprint left on the bulb with alcohol.

Install in the reverse order of removal.  
 After installation, make sure the headlight work properly.  
 Adjust the headlight beam.

### Headlight beam adjustment

Key on and turn on the headlight.  
 Turn the headlight beam adjuster to adjust headlight beam height.

#### Caution

- Do not adjust the headlight beam except for necessity.
- Improper headlight beam adjustment dazzles the coming driver / rider or results in insufficient illumination.

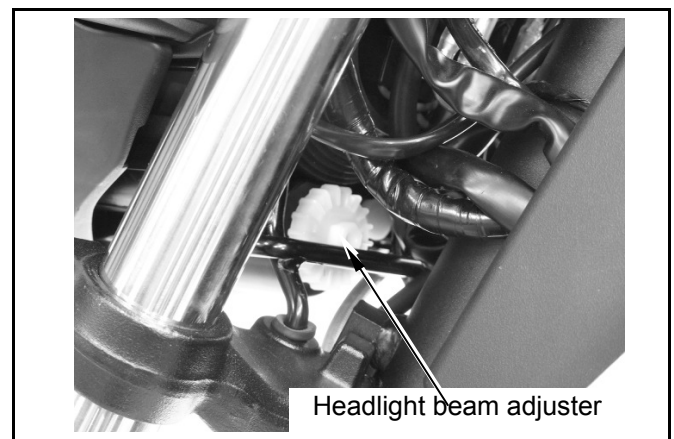
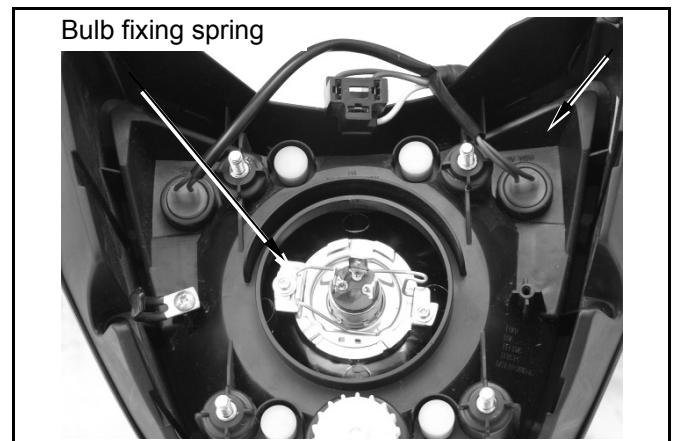
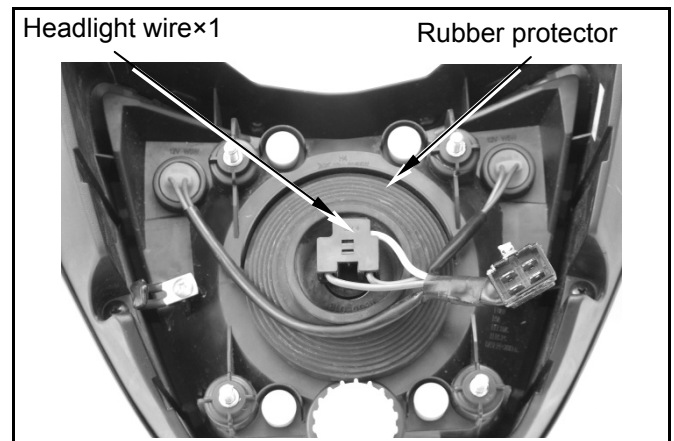
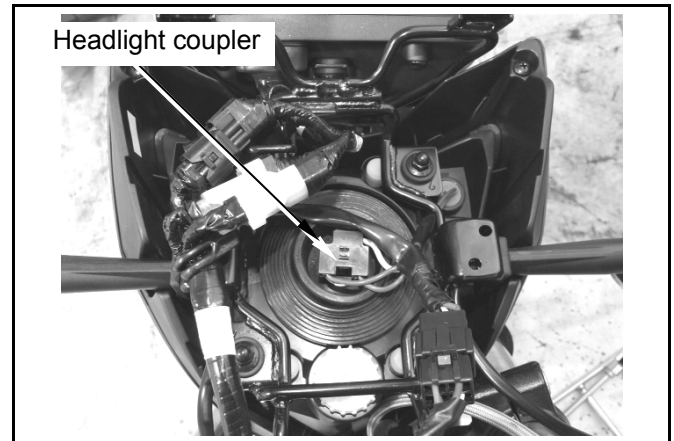

## 14. Electrical system



### Front turn light bulb replacement

Remove the front turn light lens screw.  
(screw×1)

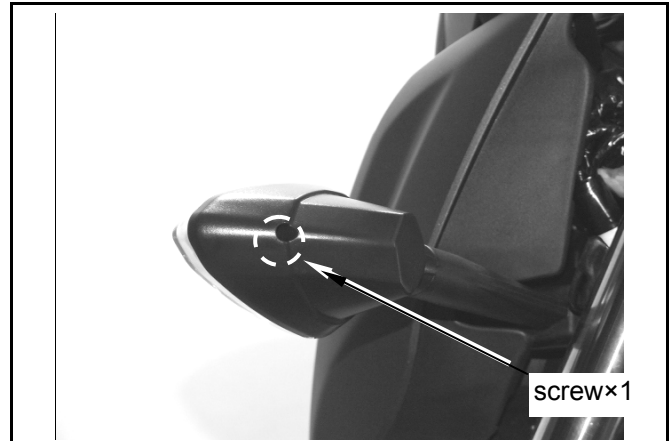

Remove the front turn light bulb socket screws.

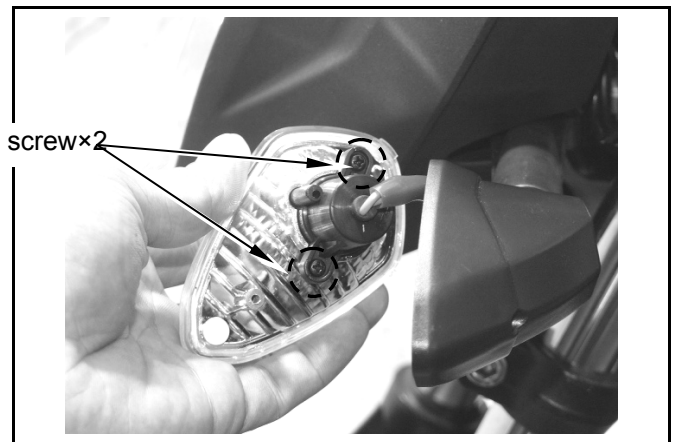

Replace the bulb. (12V 10W)  
Replace turn light socket if necessary.

### Caution

- Make sure turn light lens, case, and gasket properly sealed up during assembly.

### Installation

Install in the reverse order of removal.



### Rear turn light bulb replacement

Remove the rear turn light lens (screw x1).

 **Caution**

- Do not damage the lens when removing.

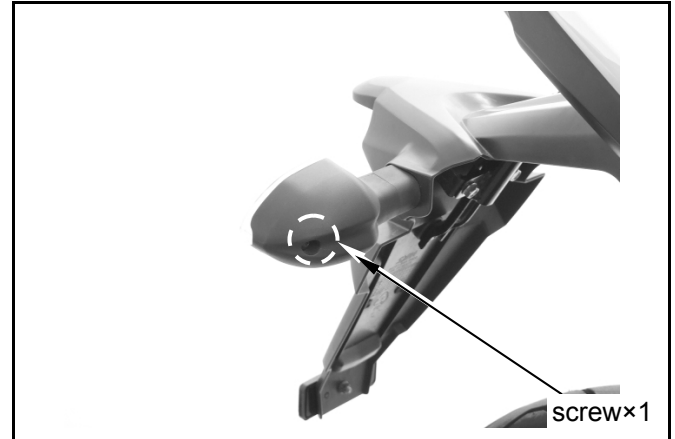

Rotate the turn light bulb socket counterclockwise and pull it out from the lens.



Replace the bulb. (12V 10W)  
Replace turn light socket if necessary.

 **Caution**

- Make sure turn light lens, case, and gasket properly sealed up during assembly.



### Installation

Install in the reverse order of removal.

## 14. Electrical system



Remove the front / rear seat and right / left body cover.

Remove the rear carrier bolts (boltX4) and rear body cover upper bolt. (boltX1)

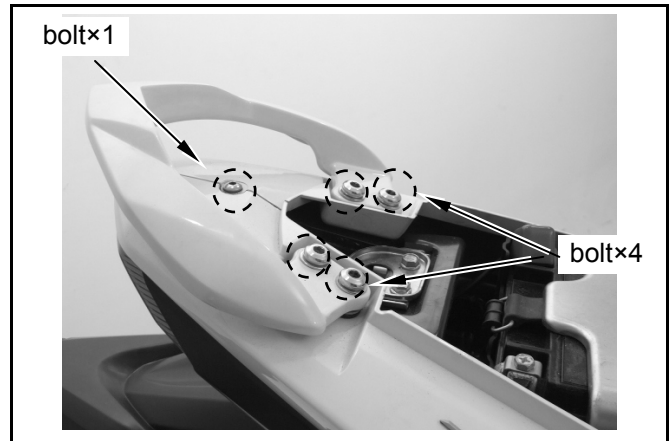

Remove the rear body cover bolts. (4 bolts for both sides)

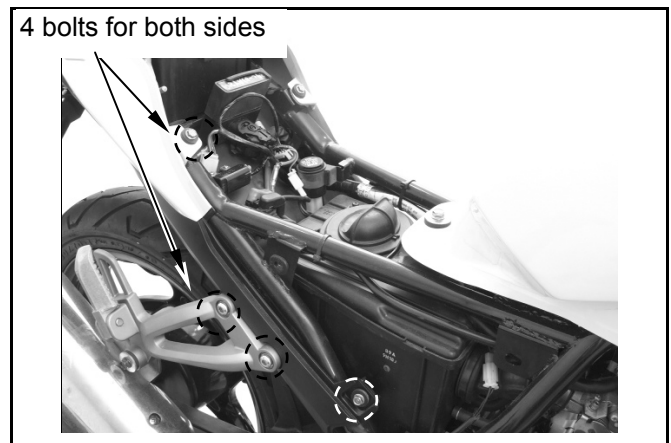

Remove the rear body cover lower bolts and screws.

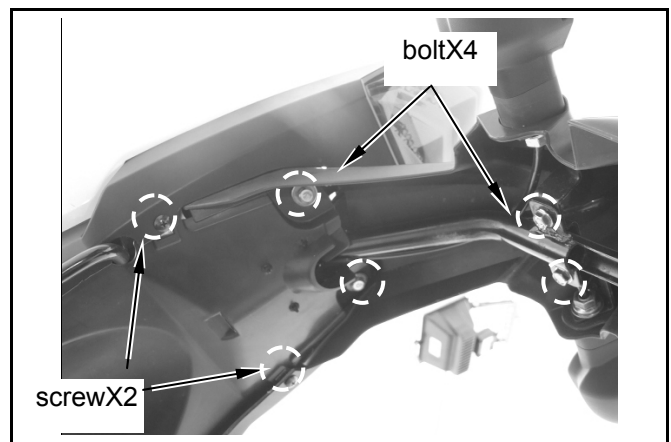

Remove the rear fender bolt.

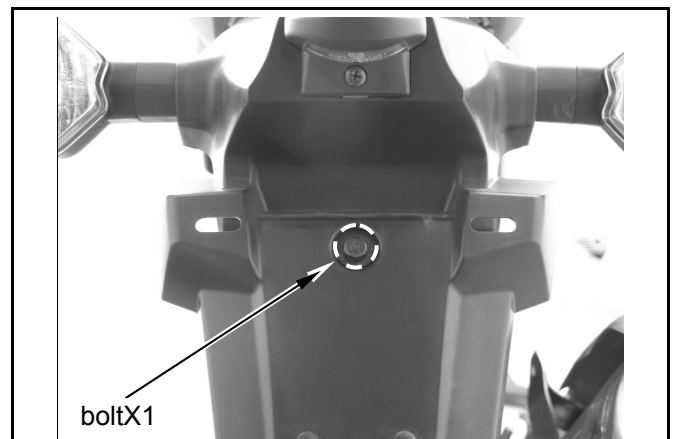



Disconnect the taillight / brake light coupler.

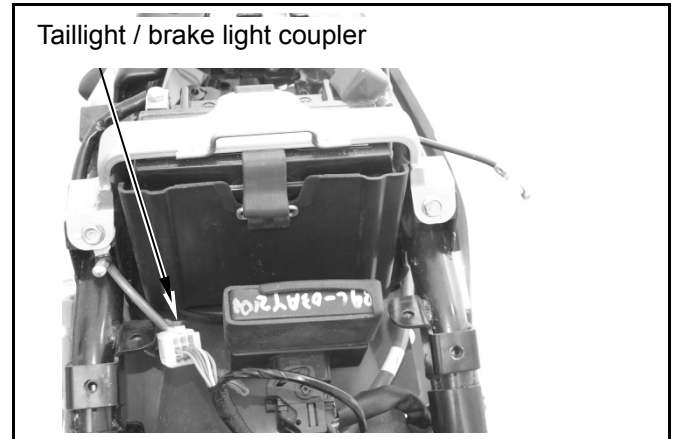

Remove the rear fender fixing screws.  
(screwX4).

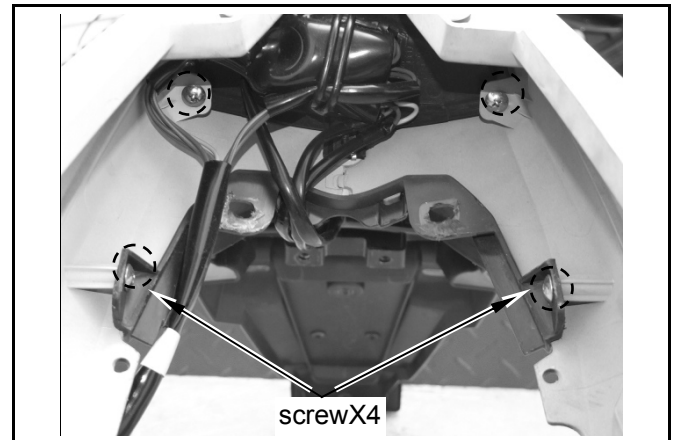

Remove the taillight screw.



Remove the taillight assembly.  
Replace the taillight as an assembly if the led  
is burned out.

Specification: taillight / brake light LED

### Installation

Install in the reverse order of removal.



## 14. Electrical system



### Switch / horn

#### Main switch

##### Inspection

Remove the headlight. (bolt×2)

Disconnect the main switch coupler.

Check the continuity between two points as indicated below

position \ pin	BAT1	BAT2	IG
LOCK			
OFF			
ON	●	●	
color	B	R	G

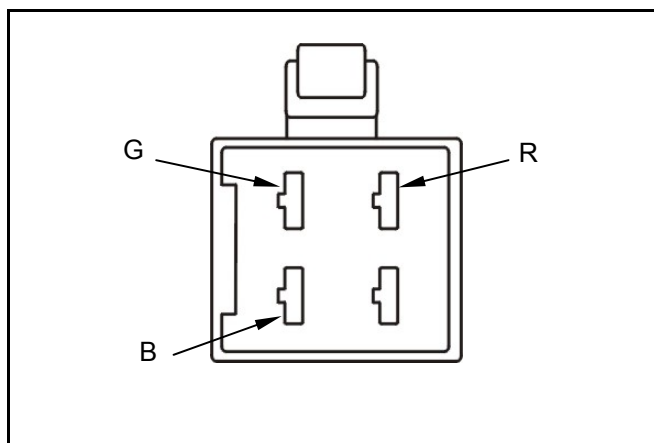
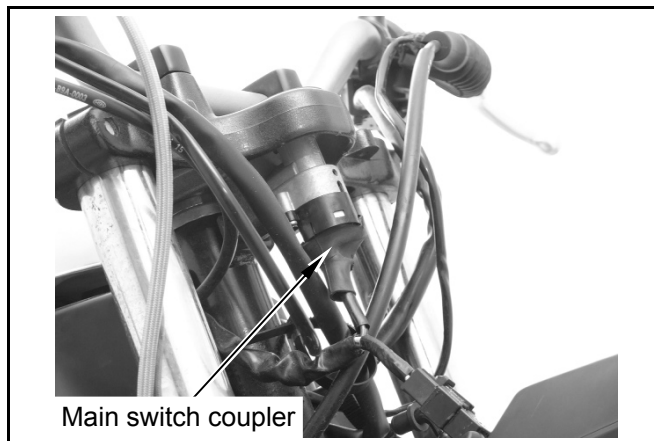

##### Replacement

Remove the headlight assembly (bolt ×2).

Disconnect the main switch coupler.

Remove the main switch. (bolt x 2)

##### Installation

Install in the reverse order of removal.

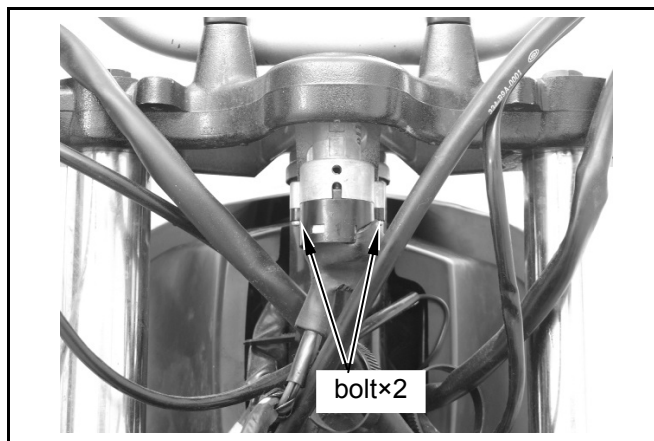

## Right handle switch

Remove the right handlebar switch coupler.

Check the following switch circuit.

### Headlight switch

position \ pin	BAT	TL	HL
•			
	●	●	
	●	●	●
color	B	BR	L/W

### Start switch

position \ pin	BAT	ST
FREE		
	●	●
color	B	Y/R

### Engine stop switch

position \ pin	ST	BAT
	●	●
color	B/G	B

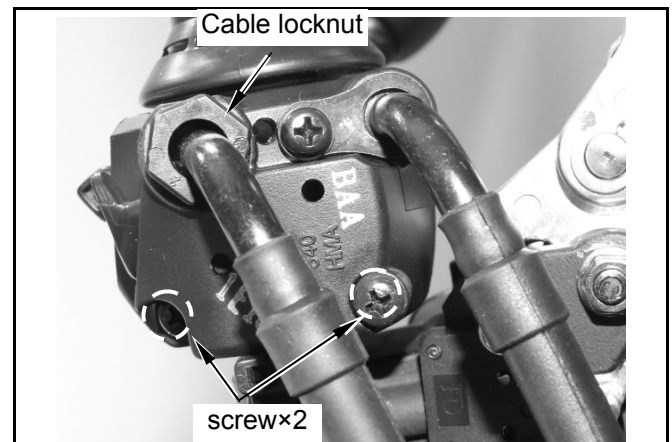
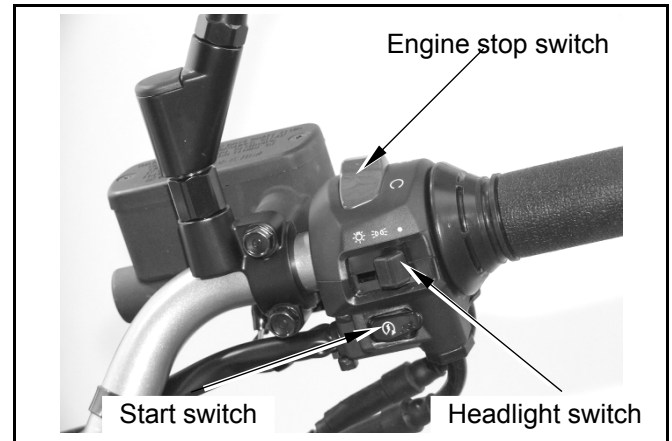

## Removal

Loosen the throttle cable locknut and remove the right handle switch screws. (screw×2)

Remove the throttle cable.

Remove the throttle grip and right handle switch.

## Installation

Install in the reverse order of removal.

Check if switch operation is normal after installation.

# 14. Electrical system



## Left handle switch

Disconnect the left handle switch wire coupler.

Check the following coupler circuit.

### Dimmer switch

pin position	HI	LO	HL	BAT
		●	●	
	●	●	●	
<b>PASS</b>	●			●
<b>color</b>	L	W	L/W	B

### Turn light switch

pin position	L	W	R
		●	●
	●	●	
<b>color</b>	O	GR	SB

### Horn switch

pin position	HO	BAT
<b>FREE</b>		
	●	●
<b>color</b>	LG	B

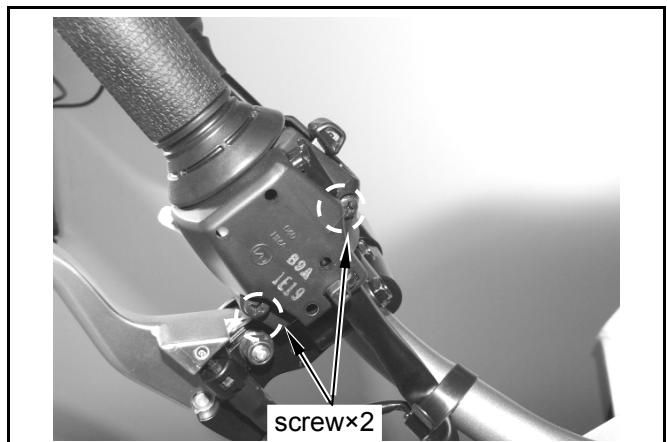
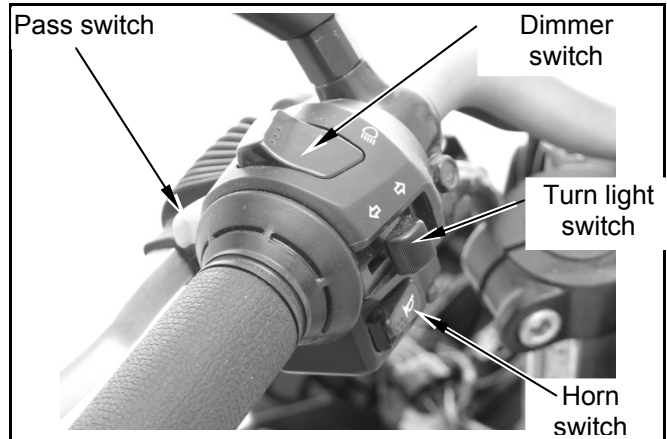

## Removal

Remove the left handle switch screws, (screw×2) remove the left handle switch.

## Installation

Install in the reverse order of removal. Check if switch operation is normal after installation.

### Brake light switch

While pulling the brake lever or stepping the rear brake pedal, the terminals of black and green/yellow of the brake should have continuity.

Replace the switch if damaged.

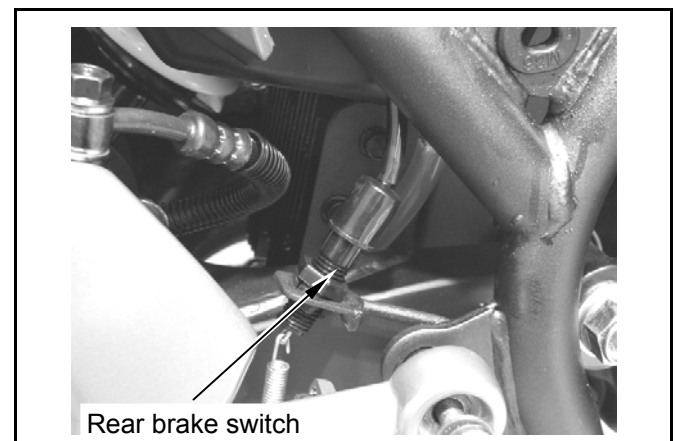
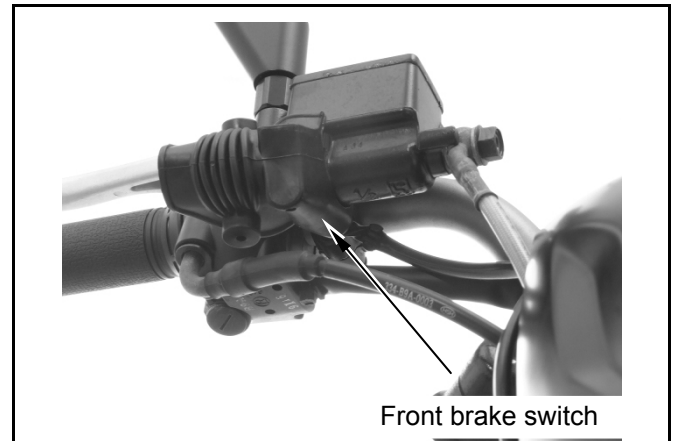

### Horn

Disconnect the horn coupler and remove the horn. (bolt x 1)

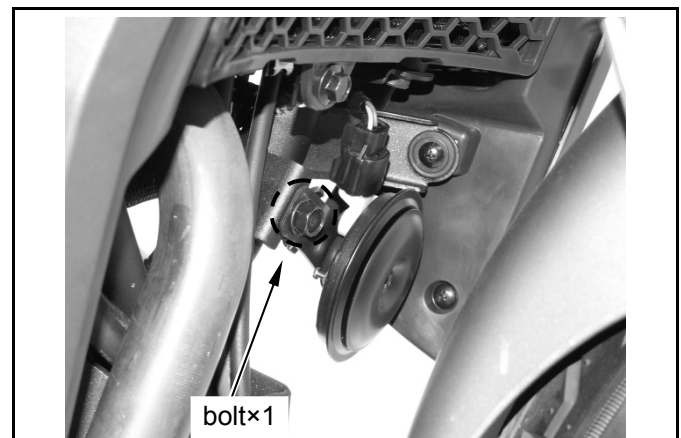

Apply 12 V power source to two terminals of the horn, the horn should sound.  
Replace the horn if necessary.

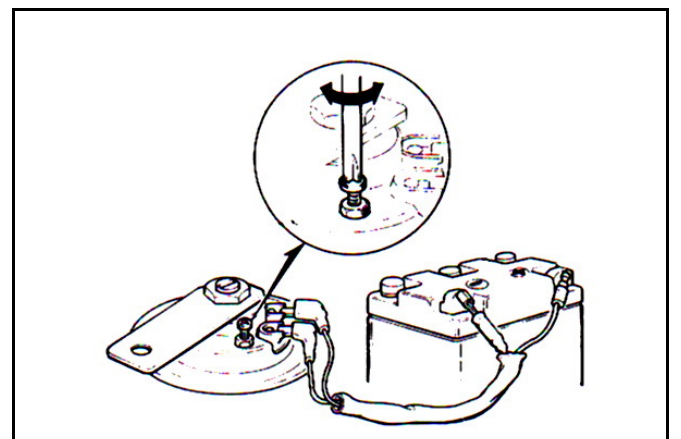

## Fuel unit

Remove the fuel tank. (Please refer to ch.3)

Disconnect the fuel unit wire coupler.  
Remove the fuel unit. (bolt×4)



- Do not bend or damage the float arm.

Connect the fuel unit coupler to the wire harness.

Turn on the main switch.

Move the float arm to verify the proper position the fuel gauge needle indicates.

Arm position	Needle position
Up (full)	F (full)
Down (empty)	E (empty)



- While conducting the test, turn on the turn light to make sure that the battery is in serviceable condition.

When the float arm shifts to the F position or the E position, the resistance measured shall be as follows:

Arm position	Resistance
Up (full)	100±5Ω
Down (empty)	600±15Ω

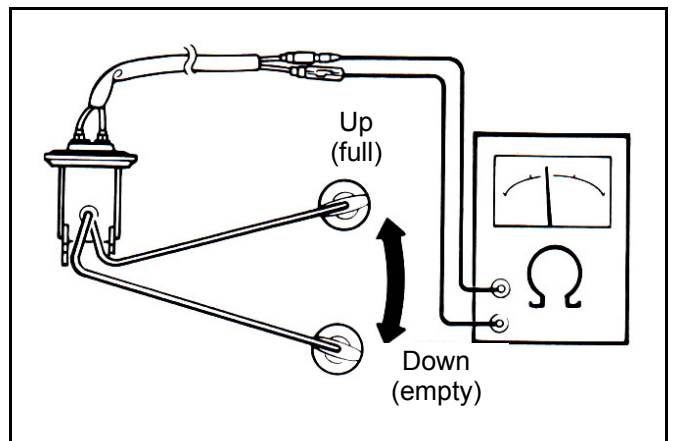
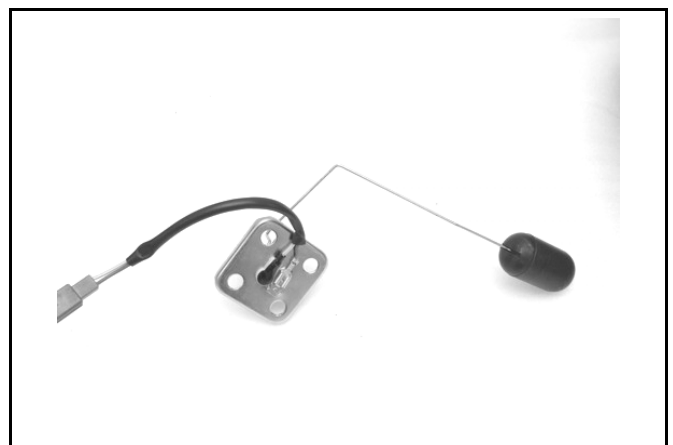
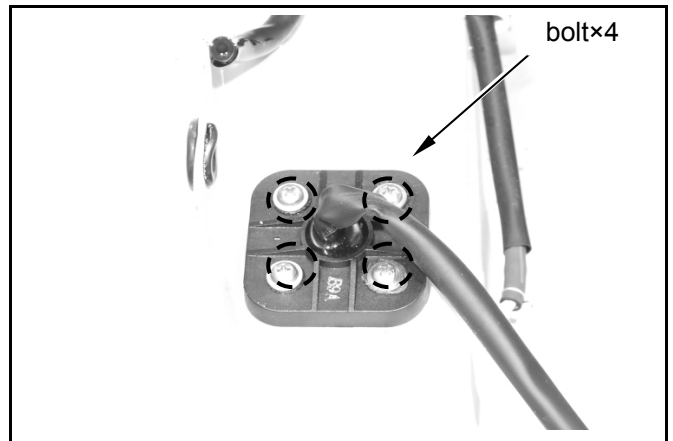

Emission Control System Mechanism..... 15-1	Positive crankcase ventilation system (P.C.V.) ..... 15-4
Function of mechanism in the emission control system ..... 15-1	Air injection solenoid valve (AISV)..... 15-5
Fuel Evaporative Emission Control system (E.E.C.) ..... 15-2	Ignition system..... 15-6
E.E.C. inspection..... 15-3	Inspection Items..... 15-7
Catalytic Converting System (C.A.T.A) .. 15-3	Countermeasure for Abnormal Emission Pollutants ..... 15-8

**Emission control system mechanism**

**Four-stroke engine model**

1. Catalyst Converter (C.A.T.A.)
2. Evaporative Emission Control System (E.E.C.)
3. Air Injection System (A.I.)
4. Positive Crankcase Ventilation System (P.C.V.)

**Function of mechanism in the emission control system**

**General**

The emission control strategy of this model was formulated basing on a four-stroke single cylinder engine. It adopts secondary air introducing device to purify the exhaust, in addition, it also adopts a charcoal canister to absorb the fuel vapor generated through evaporation in the fuel system.

**Engine refinements**

Optimum compression ratio, ignition timing, intake and exhaust timing have all contributed to maximize the intake/exhaust efficiency and combustion efficiency.

**Secondary air introducing system**

It is used to introduce secondary air into exhaust manifold so that incomplete burned exhausts, CO & HC, may be burned again and to be harmless gases.

System	Device	Components	Purpose & function
Combustion system	Combustion chamber	4-valve combustion chamber	Four valves combustion chamber is designed to achieve the combustion stability.
Exhaust system	Post-treatment device	Catalytic converter	Installed a three-way catalytic converter in the middle of exhaust pipe to oxidize the CO, HC in the exhaust gas.
EEC system	Evaporative emission control system	Activated carbon canister Purge control valve	A canister is used to absorb vapor and to introduce it into combustion chamber at an opportune timing.
A.I. system	Secondary air-injection system	Air injection solenoid valve Secondary air filter	To introduce fresh air into exhaust manifold controlled by an air cut-valve to burn the exhaust again.
PCV system	Crankcase blow-by introducing device	Vapor separator	To introduce blow-by into combustion chamber via a vapor separator for burning then discharging.

### Fuel evaporative emission control system (E.E.C.)

#### 1. Construction:

1. Reduce air-polluting HC.
2. To absorb fuel vapor and saving fuel consumption.

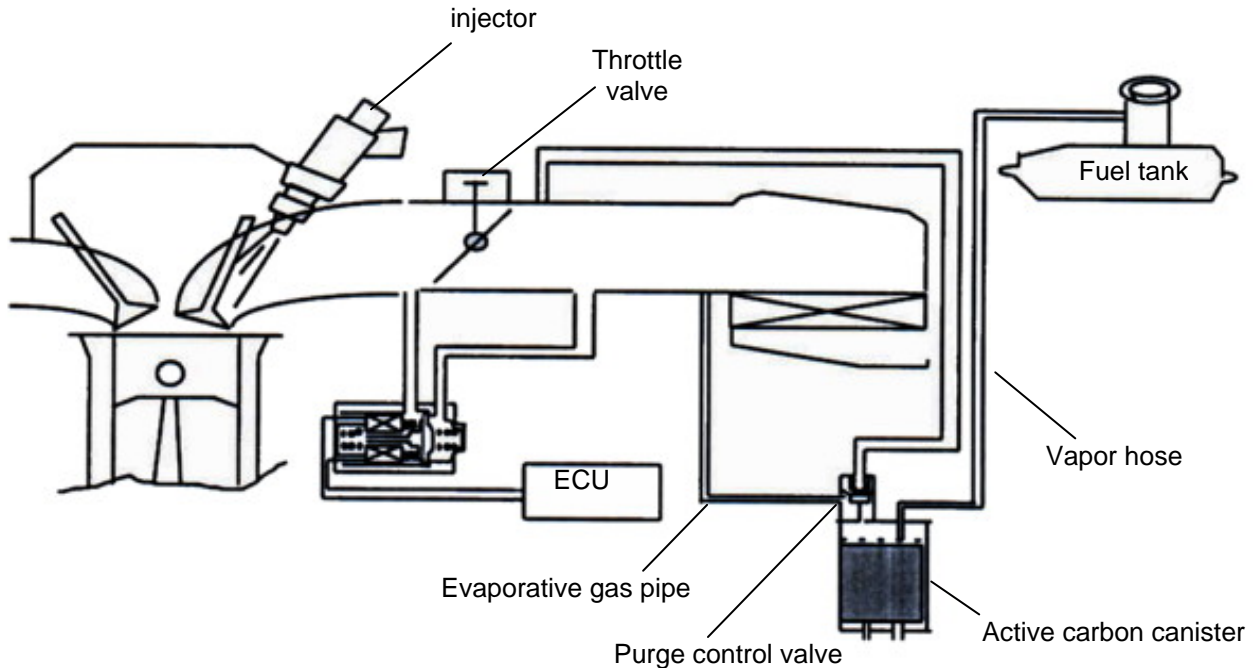

#### 2. Principle of operation

1. Vapor generated from the fuel tank and fuel system through evaporation is contained in the confined system to prevent it from escaping into the atmosphere, at the same time, the vapor will be introduced into an activated carbon canister where the hydrocarbon in the vapor will be absorbed by active carbon.
2. When the engine is running, the negative pressure of the intake manifold opens the purge line, release HC from the activated carbon and then sucks it into the engine together with air from the bottom of the canister.
3. The canister can be used repeatedly without reducing its performance because of the system's purge function.

#### 3. Troubleshooting:

- Fuel can not flow to the fuel injector
- No fuel in the fuel tank
  - Manifold vacuum hose loosened.
  - Clogged fuel system

#### 4. Cautions:

1. Do not exceed the reed valve of the fuel filler when filling fuel.
2. Do not accelerate forcefully or ride on high speed when applying the spare fuel.



## Evaporative Emission Control System (E.E.C.) Inspection

### 1. Visual check

Check all hoses for breakage.

### 2. Purge Control Valve (P.C.V.) function test:

Disconnect the hose of connection to the active carbon canister, and then connect a T-type hose connector to pressure source as shown below:

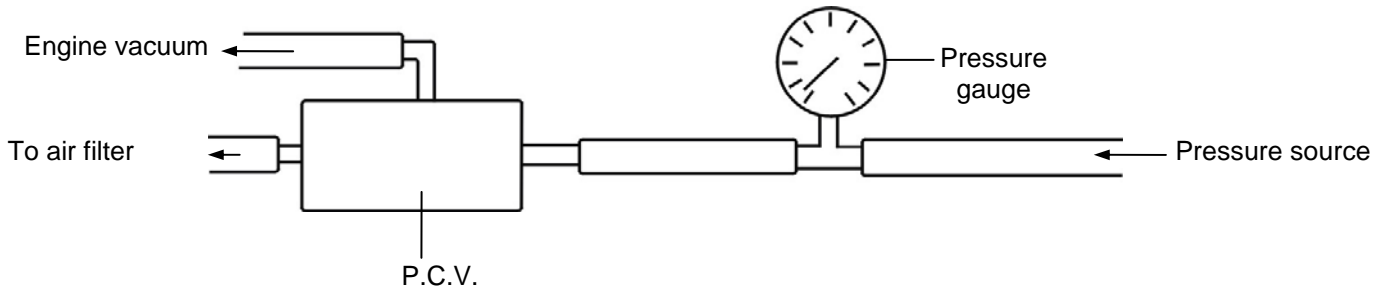

Apply 100mmAq into pressure source inlet as engine stopped then plug it. The pressure at the gauge should not drop to below 10mmAq within 10 seconds.

## Catalytic converter (C.A.T.A.) :

### 1. Construction:

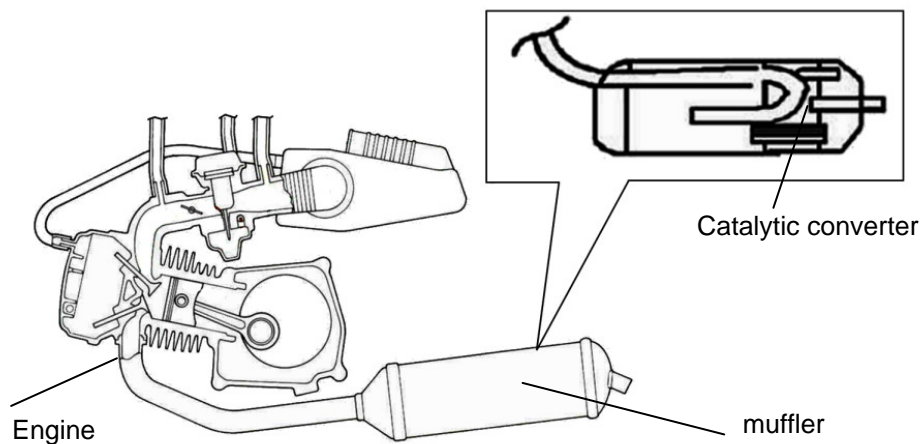

### 2. Description:

1. The function of the catalytic converter is to transfer unburned CO, HC, and NOx to harmless CO<sub>2</sub>, H<sub>2</sub>O, N<sub>2</sub> gases.
2. Catalytic converter contains rare metals such as Pt, Pd, Rh. Use only unleaded gasoline to prevent the catalytic converter from malfunction.

### Positive Crankcase Ventilation System (P.C.V.)

#### 1. Construction

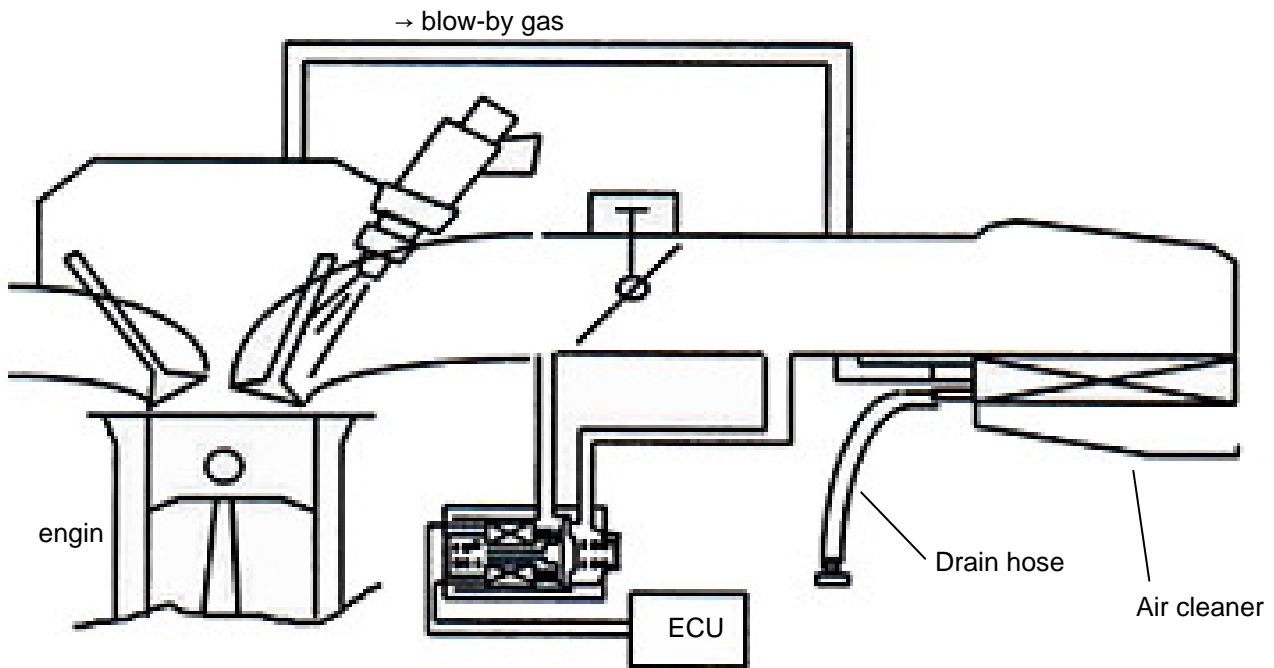

#### 2. Principle of operation

1. Install a separated chamber on cylinder head, and suck the blow-by gas to the fuel vapor separator by engine vacuum.
2. Drill a hole in the air cleaner and install a vapor separator, so that blow-by from crankcase will flow through a cylinder check valve and then separated by the separator.
3. The separated vapor will be sucked into combustion chamber by engine negative pressure to be burned again instead of discharging into atmosphere. Drain liquidized fuel in the drain pipe periodically.

#### 3. Service method

##### Visual check

- Drain the fuel when the level reaches 80% in the drain pipe.
- Check if hose damaged or loosened.

## Air injection solenoid valve(AISV)

### Description

To promote stable combustion and idle speed, an open loop is applied to maintain air / fuel ratio on 13 : 1, AISV is used to neutralize pollutants like CO and HC.

ECU can accurately control AISV according to RPM and engine vacuum to avoid the backfiring situation of traditional carburetor-type bikes.

AISV consumes higher current; to save power in idle speed, AISV is designed normal open, which means that air inlet and outlet holes are unobstructed while no power supply, and can introduce secondary air into exhaust gas.

### Act condition

1. AISV act: in idle speed and low speed (under 15km/h), ECU do not let AISV earth, thus valve is open and secondary air can be introduced into exhaust gas. Generally speaking, AISV can neutralize 50% CO. (Ex: The original CO is 4%, after secondary air introduced, CO could be lowered to 2%). To prevent backfiring, secondary air will be introduced while RPM is under 3000.

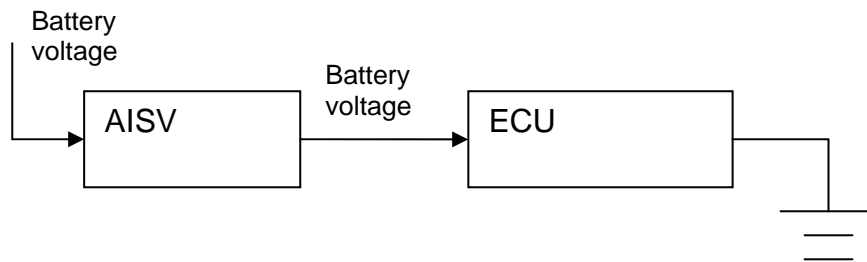

1. AISV no act: While speed is over 15km/h, ECU will let AISV earth, after AISV is off, secondary air introduced to exhaust gas will be cut off.

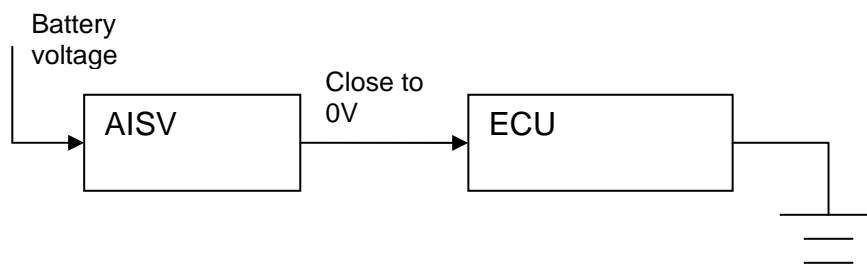

## Ignition system Ignition circuit

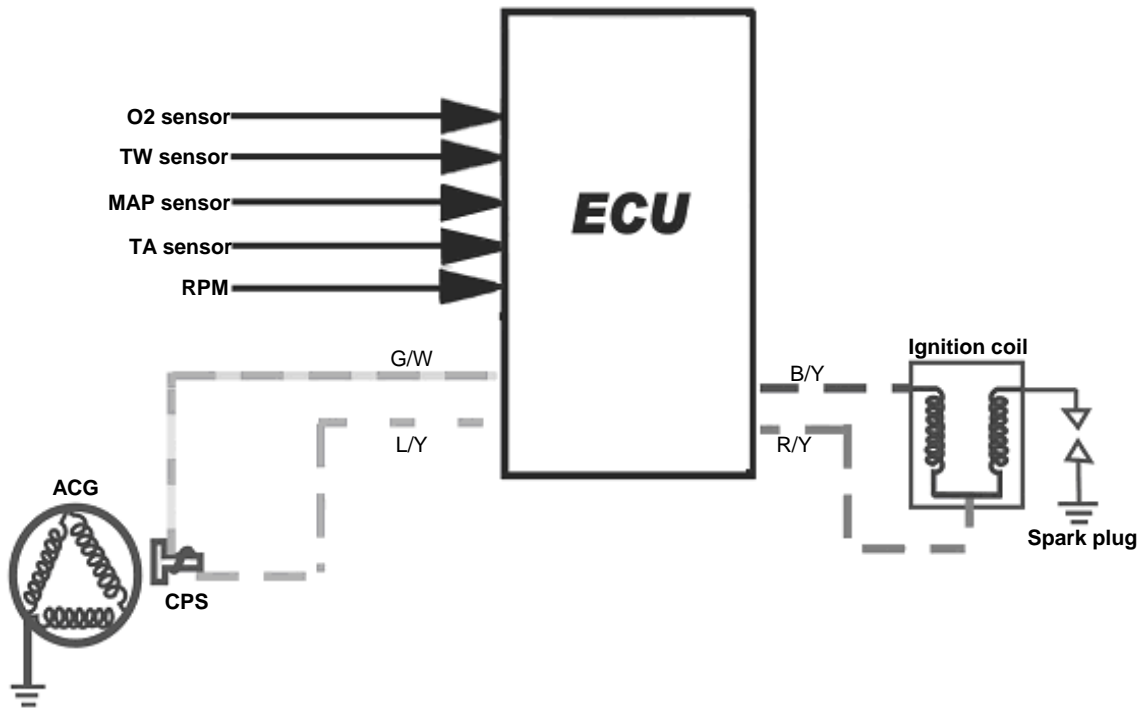

### Principle

The computer programmed ignition system receives the signals from the Crankshaft position sensor, Throttle position sensor, O<sub>2</sub> Sensor, MAP sensor, Intake air temperature sensor, Engine coolant temperature sensor. Calculating the engine RPM, the 16-bit microcomputer determines the appropriate ignition timing, controls the ignition coil and triggers the spark plug. This way can not only make the engine achieve the maximum power output, but also help improve fuel consumption rate.

### Inspection items

#### Evaporative emission control system:

- Visual check if charcoal canister and hose damaged.
- Check if any leakage.
- Check purge control valve.

#### Catalytic converter:

- Remove and shake exhaust pipe to check if any abnormal noise.
- Check if emission within standard.

#### Fuel system

- Clean air filter.
- Check fuel filter.
- Clean injector and fuel hose by compressed air or specified solvent.
- Adjust idle speed CO/HC value. (RPM within standard)

#### Ignition System:

- Check or replace spark plug.
- Check or replace ignition coil.

## Countermeasure for abnormal emission pollutants

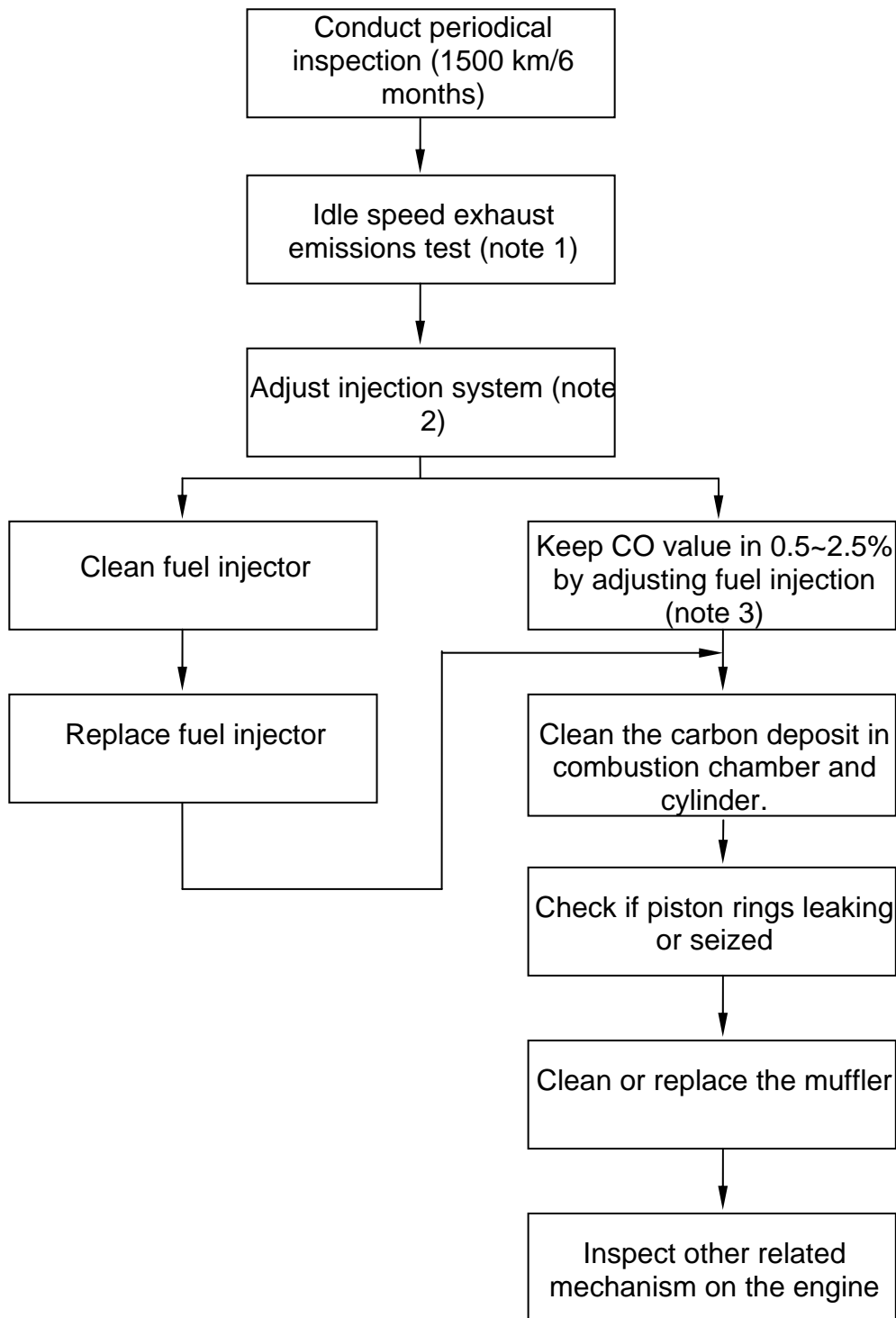

Note 1. Test in accordance with the idling test procedure.

Note 2. Adjust CO with diagnostic tool, set idle speed within standard, measure CO and HC on idle speed, and adjust CO set value in injection system , adjust CO emission value around 0.5~2.5 %.

Note 3. If CO value can not be adjusted to the default value by adjusting ECU, follow the procedures to check or replace components.

NOTE:

---

**NOTE:**



T2 電路圖

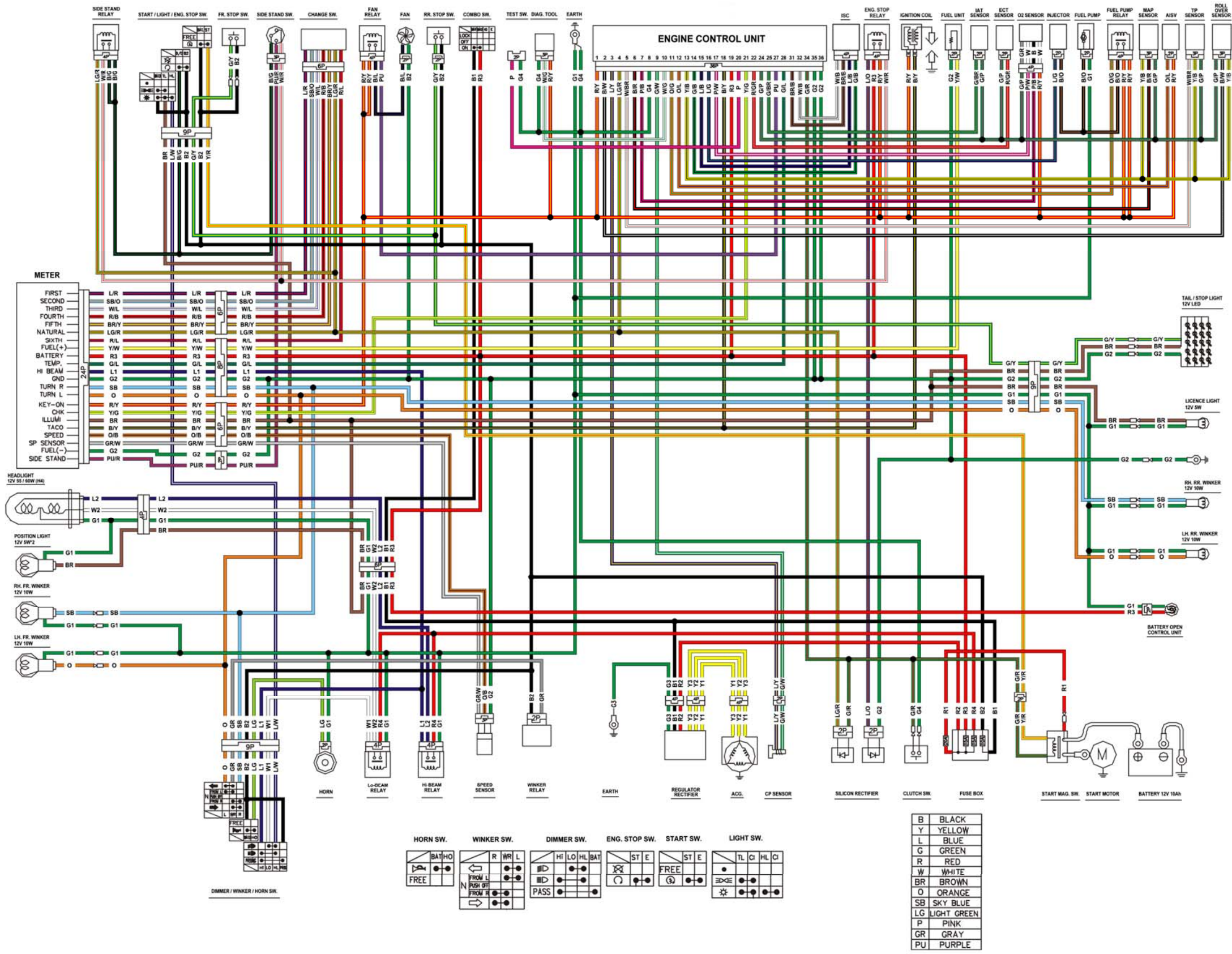

NOTE: