















SYMBOLS AND MARKS 1-1	TORQUE VALUES (ENGINE)..... 1-10
GENERAL SAFETY..... 1-2	TORQUE VALUES (FRAME)..... 1-11
SERVICE PRECAUTIONS..... 1-3	TROUBLES DIAGNOSIS 1-12
SPECIFICATIONS..... 1-9	LUBRICATION POINTS..... 1-16

SYMBOLS AND MARKS

Symbols and marks are used in this manual to indicate what and where the special service are needed, in case supplemental information is procedures needed for these symbols and marks, explanations will be added to the text instead of using the symbols or marks.

 Warning	Means that serious injury or even death may result if procedures are not followed.
 Caution	Means that equipment damages may result if procedures are not followed.
 Engine oil	Limits to use SAE 10W-30 API SH/CD class oil. Warranty will not cover the damage that caused by not apply with the limited engine oil.
 Gear oil	Limits to use SAE 85W-140 class oil. Warranty will not cover the damage that caused by not apply with the limited gear oil.
 Grease	King Mate G-3 is recommended.
 Locking sealant	Apply sealant, medium strength sealant should be used unless otherwise specified.
 Oil seal	Apply with lubricant.
 Renew	Replace with a new part before installation.
 Brake fluid	Use recommended brake fluid DOT3 or WELLRUN brake fluid.
 Special tools	Special service tools.
 Correct	Meaning correct installation.
 Wrong	Meaning wrong installation.
 Indication	Indication of components.
 Directions	Indicates position and operation directions.
	Components assembly directions each other.
	Indicates where the bolt installation direction, --- means that bolt cross through the component (invisibility).

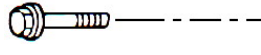
GENERAL SAFETY

Carbon monoxide

If you must run your engine, ensure the place is well ventilated. Never run your engine in a closed area. Run your engine in an open area, if you have to run your engine in a closed area, be sure to use an extractor.

Caution

Exhaust contains toxic gas which may cause one to lose consciousness and even result in death.

Gasoline

Gasoline is a low ignition point and explosive material. Work in a well-ventilated place, no flame or spark should be allowed in the work place or where gasoline is being stored.

Caution

Gasoline is highly flammable, and may explode under some conditions, keep it away from children.

Used engine oil

Caution

Prolonged contact with used engine oil (or transmission oil) may cause skin cancer although it might not be verdict.

Hot components

Caution

Components of the engine and exhaust system can become extremely hot after engine running. They remain very hot even after the engine has been stopped for some time. When performing service work on these parts, wear insulated gloves and wait until cooling off.

Battery

Caution

- Battery emits explosive gases; flame is strictly prohibited. Keep the place well ventilated when charging the battery.
- Battery contains sulfuric acid (electrolyte) which can cause serious burns so be careful do not be spray on your eyes or skin. If you get battery acid on your skin, flush it off immediately with water. If you get battery acid in your eyes, flush it off immediately with water, then go to hospital to see an ophthalmologist.
- If you swallow it by mistake, drink a lot of water or milk, and take some laxative such as castor oil or vegetable oil, and then go to see a doctor.
- Keep electrolyte beyond reach of children.

Brake shoe

Do not use an compressed air or a dry brush to clean components of the brake system, use a vacuum cleaner or the equivalent to avoid asbestos dust flying.

Caution

Inhaling asbestos dust may cause disorders and cancer of the breathing system.

Brake fluid

Caution

Spilling brake fluid on painted, plastic, or rubber parts may cause damage to the parts. Place a clean towel on the above-mentioned parts for protection when servicing the brake system. Keep brake fluid beyond reach of children.

SERVICE PRECAUTIONS

- Always use with SANYANG genuine parts and recommended oils. Using non-designed parts for SANYANG motorcycle may damage the motorcycle.

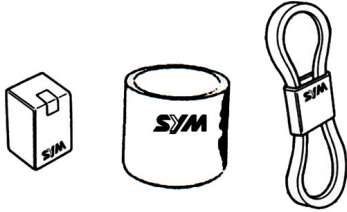

- Special tools are designed for remove and install of components without damaging the parts being worked on. Using wrong tools may result in parts damaged.

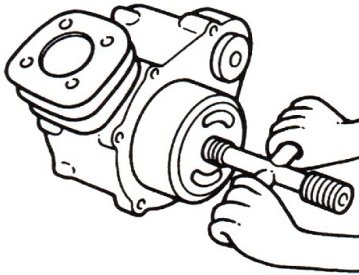

- When servicing this motorcycle, use only metric tools. Metric bolts, nuts, and screws are not interchangeable with the English system, using wrong tools and fasteners may damage this vehicle.
- Clean the outside of the parts or the cover before removing it from the motorcycle. Otherwise, dirt and deposit accumulated on the part's surface may fall into the engine, chassis, or brake system to cause a damage.
- Wash and clean parts with high ignition point solvent, and blow dry with compressed air. Pay special attention to O-rings or oil seals because most cleaning agents have an adverse effect on them.

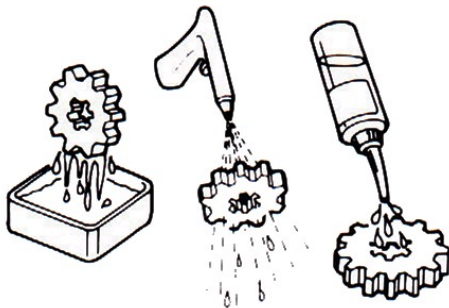

- Never bend or twist a control cable to prevent stiff control and premature worn out.



- Rubber parts may become deteriorated when old, and prone to be damaged by solvent and oil. Check these parts before installation to make sure that they are in good condition, replace if necessary.
- When loosening a component which has different sized fasteners, operate with a diagonal pattern and work from inside out. Loosen the small fasteners first. If the bigger ones are loosen first, small fasteners may receive too much stress.
- Store complex components such as transmission parts in the proper assemble order and tie them together with a wire for ease of installation later.

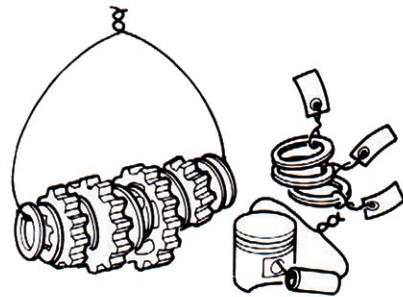

- Note the reassemble position of the important components before disassembling them to ensure they will be reassembled in correct dimensions (depth, distance or position).
- Components not to be reused should be replaced when disassembled including gaskets metal seal rings, O-rings, oil seals, snap rings, and split pins.



- The length of bolts and screws for assemblies, cover plates or boxes is different from one another, be sure they are correctly installed. In case of confusion, Insert the bolt into the hole to compare its length with other bolts, if its length out side the hole is the same with other bolts, it is a correct bolt. Bolts for the same assembly should have the same length.

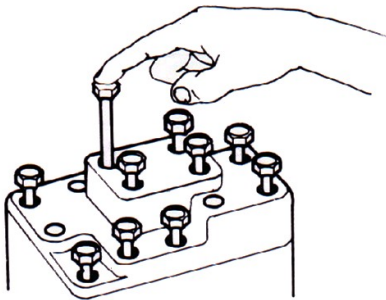

- Tighten assemblies with different dimension fasteners as follows:
- Tighten all the fasteners with fingers, then tighten the big ones with special tool first diagonally from inside toward outside, important components should be tightened 2 to 3 times with appropriate increments to avoid warp unless otherwise indicated. Bolts and fasteners should be kept clean and dry. Do not apply oil to the threads.

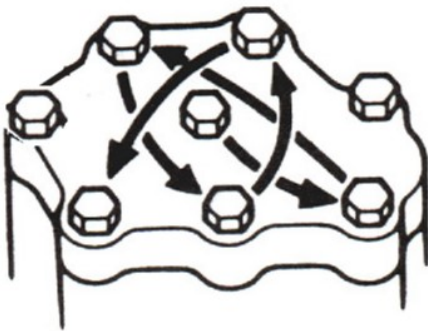

- When oil seal is installed, fill the groove with grease, install the oil seal with the name of the manufacturer facing outside, check the shaft on which the oil seal is to be installed for smoothness and for burrs that may damage the oil seal.

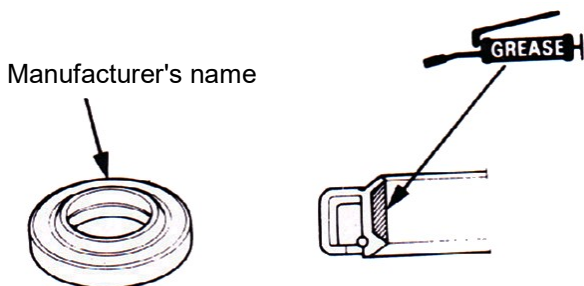

- Remove residues of the old gasket or sealant before reinstallation, grind with a grindstone if the contact surface has any damage.

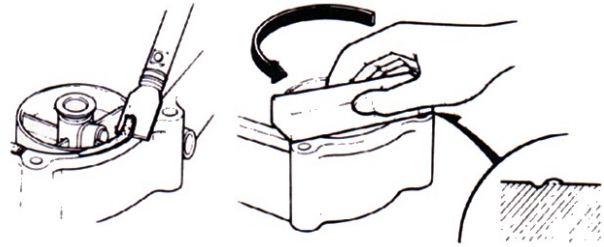

- The ends of rubber hoses (for fuel, vacuum, or coolant) should be pushed as far as they can go to their connections so that there is enough room below the enlarged ends for tightening the clamps.

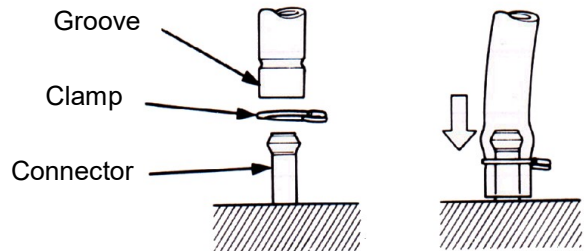

- Rubber and plastic boots should be properly reinstalled to the original correct positions as designed.

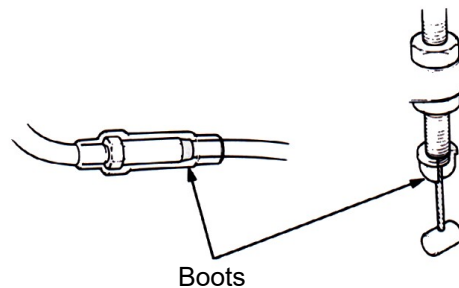

- The tool should be pressed against two (inner and outer) bearing races when removing a ball bearing. Damage may result if the tool is pressed against only one race (either inner race or outer race). In this case, the bearing should be replaced. To avoid damaging the bearing, use equal force on both races.

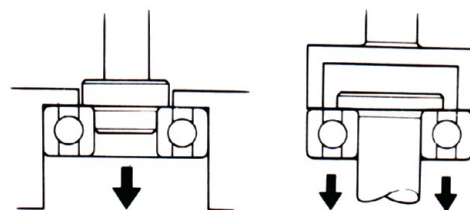

Both of these examples can result in bearing damage.

- Lubricate the rotation face with specified lubricant on the lubrication points before assembling.

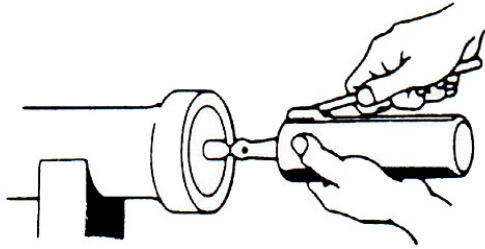

- Check if positions and operation for installed parts is in correct and properly.

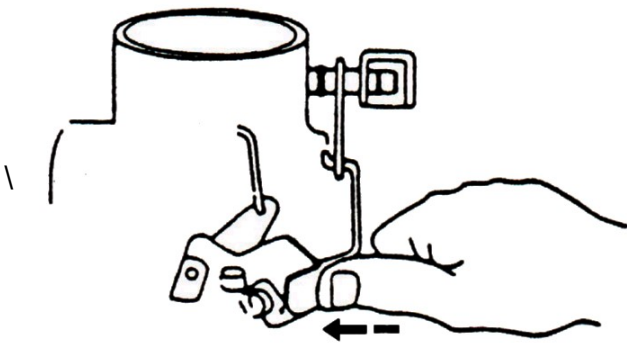

- Make sure service safety each other when conducting by two persons.

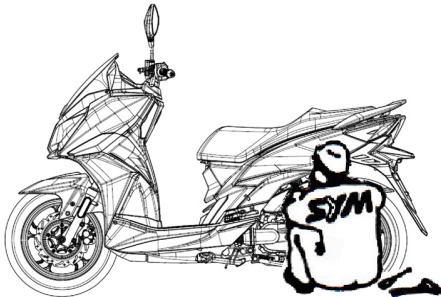

- Note that do not let parts fall down



- Before battery removal operation, it has to remove the battery negative (-) cable firstly. Notre tools like open-end wrench do not contact with body to prevent from circuit short and create spark.

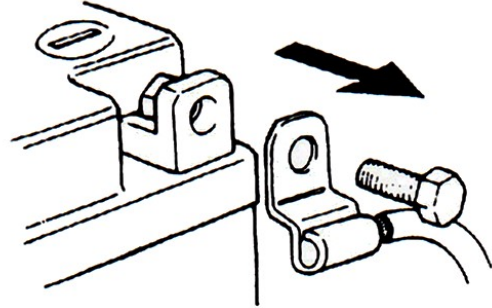

- After service completed, make sure all connection points is secured. Battery positive (+) cable should be connected firstly. And the two posts of battery have to be greased after connected the cables.

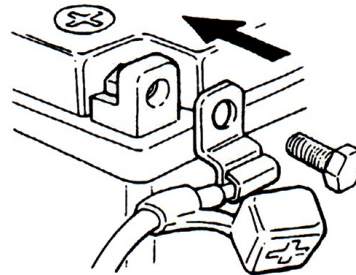

- Make sure that the battery post caps are located in properly after the battery posts had been serviced.

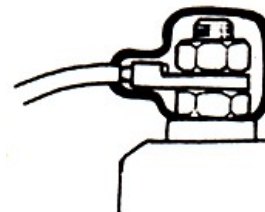

- If fuse burned, it has to find out the cause and solved it. And then replace with specified capacity fuse.

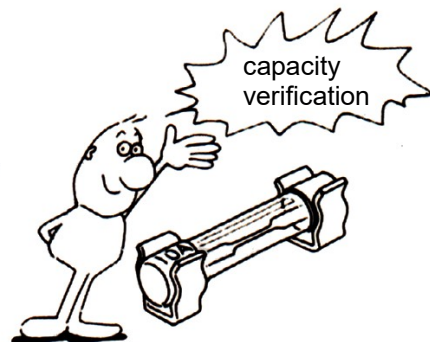

- When separating a connector, it locker has to be unlocked firstly. Then, conduct the service operation.

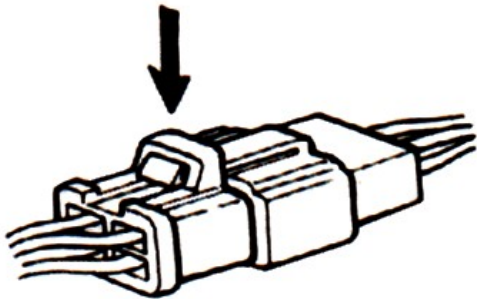

- Do not pull the wires as removing a connector or wires. Hold the connector body.

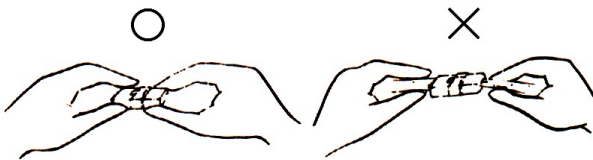

- Make sure if the connector pins are bent, extruded or loosen.

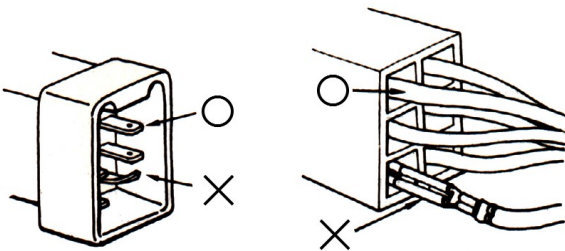

- Insert the connector completely. If there are two lockers on two connector sides, make sure the lockers are locked in properly. Check if any wire loose.

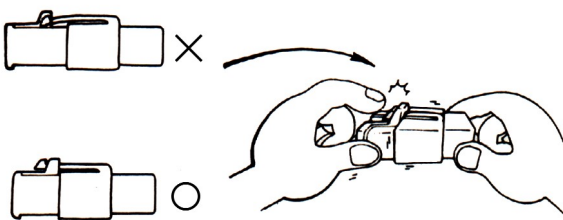

- Check if the connector is covered by the twin connector boot completely and secured properly.

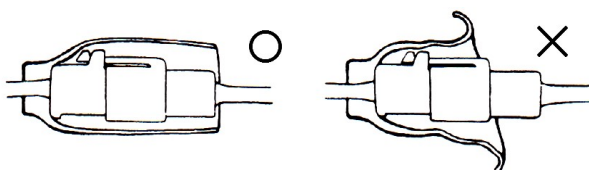

- Before terminal connection, check if the boot is crack or the terminal is loose.

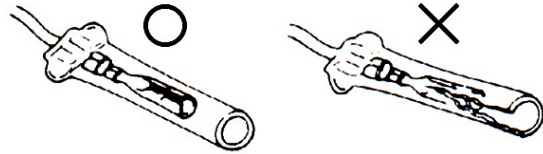

- Insert the terminal completely. Check if the terminal is covered by the boot. Do not let boot open facing up.

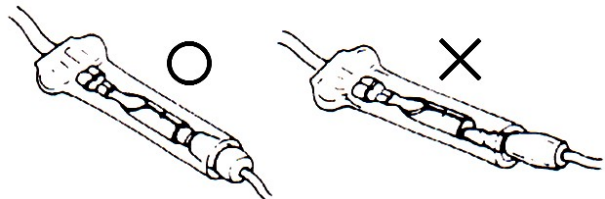

- Secure wires and wire harnesses to the frame with respective wire bands at the designated locations. Tighten the bands so that only the insulated surfaces contact the wires or wire harnesses.

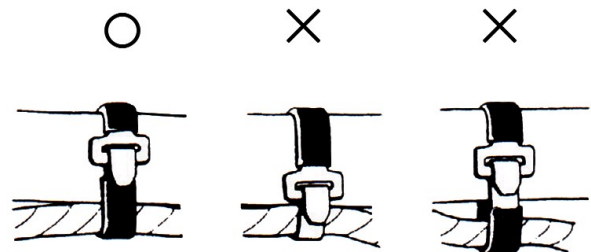

- Wire band and wire harness have to be clamped secured properly.

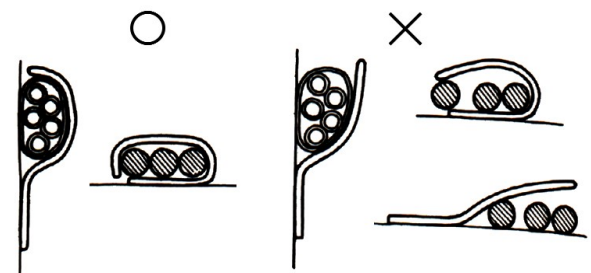

- Do not squeeze wires against the weld or its clamp.



- Do not let the wire harness contact with rotating, moving or vibrating components as routing the harness.

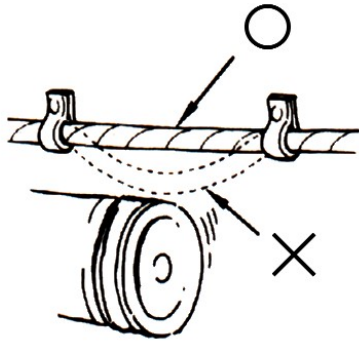

- Keep wire harnesses far away from the hot parts.

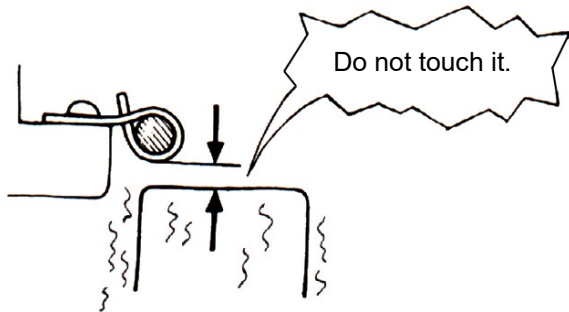

- Route wire harness to avoid sharp edges or corners and also avoid the projected ends of bolts and screws.

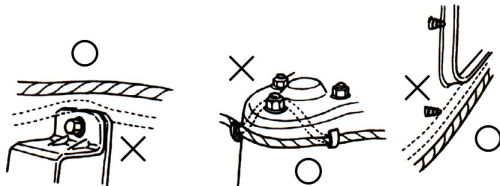

- Route harnesses so that they neither pull too tight nor have excessive slack.

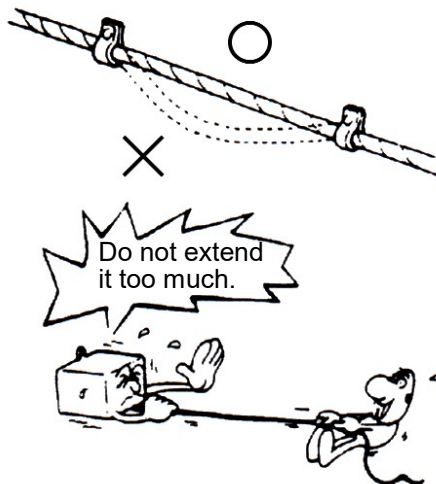

- Protect wires or wire harnesses with electrical tape or tube if they contact a sharp edge or corner. Thoroughly clean the surface where tape is to be applied.

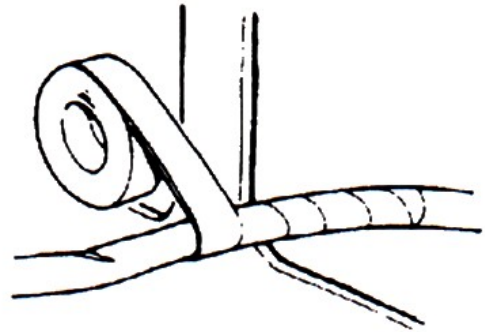

- Secure the rubber boot firmly as applying it on wire harness.

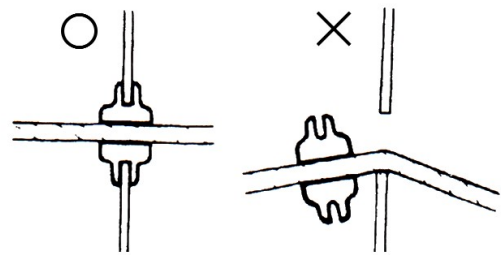

- Never use wires or harnesses which insulation has been broken. Wrap electrical tape around the damaged parts or replace them.

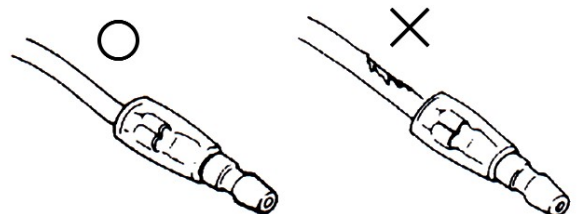

- Never clamp or squeeze the wire harness as installing other components.

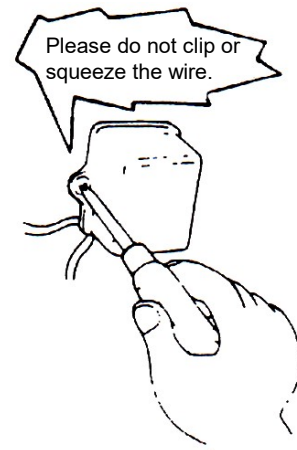

- Do not let the wire harness been twisted as installation.

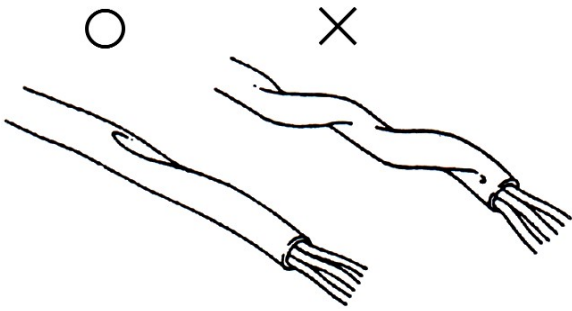

- With sand paper to clean rust on connector pins/terminals if found. And then conduct connection operation later.



- Wire harnesses routed along the handlebar should not be pulled too tight or have excessive slack, be rubbed against or interfere with adjacent or surrounding parts in all steering positions.

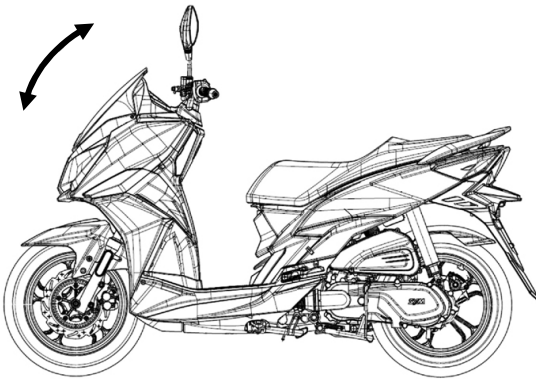

- Before operating a test instrument, operator should read the operation manual of the instrument. And then, conduct test in accordance with the instruction.

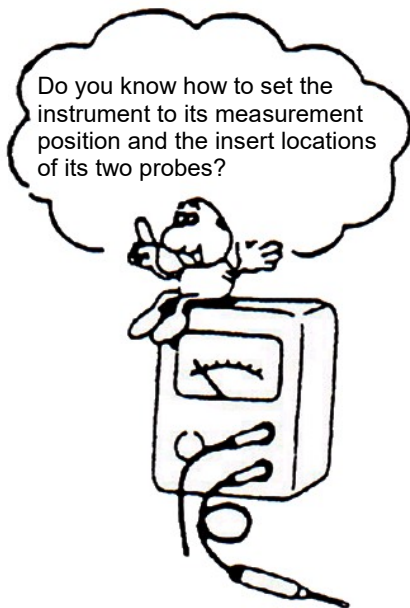

SPECIFICATIONS

MAKER		SANYANG		MODEL		XC20W2-EU		
DIMENSION	Overall Length	1990±20mm		Suspension System	Front	TELESCOPIC FORK		
	Overall Width	730±10mm			Rear	DOUBLE SWING ARM		
	Overall Height	1115±20mm		Tire Specifications	Front	100/90-14		
	Wheel Base	1350±20mm			Rear	110/80-14		
WEIGHT	Curb Weight	Front	53±2 kg		Brake System	Front	DISK (ø 260 mm)	
		Rear	81±3 kg					
		Total	134±6kg			Rear	DISK (ø 220 mm)	
	Passengers/Weight		Two men/184 kg		Performance	Max. Speed		95 km/hr Above
	Total Weight	Front	89±3kg			Climb Ability		32.5 %% slope
		Rear	195±3 kg		Deceleration equipment	Primary Reduction		C.V.T.
		Total	284±6kg			Secondary Reduction		belt, 2.604~ 0.717
ENGINE	Type		4-STROKE ENGINE		Deceleration equipment	Clutch		Centrifugal, dry type
	Installation and arrangement		Vertical, below center, incline 80°			Transmission		V-belt
	Fuel Used		unlead gasoline			Speedometer		0 ~ 140 km/hr
	Cycle/Cooling		4-stroke/forced air cooled		Horn		87~112 dB/A	
	Cylinder	Bore	61 mm		Muffler		Expansion & Pulse Type	
		Stroke	57.8 mm		Exhaust Pipe Position and Direction		Right side, and Backward	
		Number/Arrangement	Single Cylinder		Lubrication System		forced circulation & splashing	
	Displacement		169cc		Exhaust Emission (IDLE)	CO%	<1.14 g/km	
	Compression Ratio		10.3±0.2 : 1			HC%	<0.38 g/km	
	Idle speed		1800±100 rpm		Fuel tank capacity		7.5L	
	Max. HP		9KW / 7500 rpm		Air Filtration		Paper filter	
	Max. Torque		12.5N.m /6000 rpm		Noise Emission		< 74dB	
	ECU		M4B		Fuse		25A*1&15A*2 &20A*1&10A*1	
	Starting System		Electrical starter					

TORQUE VALUES (ENGINE)

ITEM	Q'TY	THREAD DIA (mm)	TORQUE VALUE(Kg-m)	REMARKS
A.C. generator flange bolts	2	6	0.8~1.2	
L side cover plate pan screws	7	5	0.5~0.7	
Engine oil filter screen cover	1	30	1.0~2.0	
Crankcase bolts	2	6	0.8~1.2	
Oil pump flat screws	2	6	0.8~1.2	
Cylinder/cylinder head two-ends bolts	4	8	0.7~1.1	Tighten to crankcase
Cylinder head left side bolts	2	6	0.7~1.1	
Camshaft sprocket bolts	2	6	1.0~1.5	
Valve adjustment fixing nuts	2	5	0.7~1.1	Apply oil to thread
Camshaft chain Tensioner bolts	2	6	0.8~1.2	
A/I fixing flange bolts	4	6	0.8~1.2	
Oil pump separator bolts	2	6	0.8~1.2	
One-way clutch lock nut	1	22	9.0~10.0	Apply oil to thread
Right crankcase cover bolts	10	6	0.7~1.1	
Pulse generator bolts	2	5	0.4~0.6	
A.C. generator flange bolts	2	5	0.8~1.2	
Flywheel nut	1	12	5.0~6.0	
Cooling fan flange bolts	4	6	0.8~1.2	
Shroud A/B	2	6	0.7~1.1	
Engine oil draining plug bolt	1	12	3.5~4.5	
Start motor bolts	2	6	0.7~1.1	
Transmission bolts	7	8	2.6~3.0	
Gear oil draining plug	1	8	1.0~1.5	
Gear oil filling bolt	1	8	1.0~1.5	
Driven pulley nut	1	12	5.5~6.0	
Driving face nut	1	12	5.0~6.0	
Left crankcase cover bolts	8	6	0.8~1.2	
Cylinder head holder nuts	4	8	1.8~2.2	
Cylinder head cover bolts	4	6	0.8~1.2	
Spark plug	1	10	1.0~1.2	
Carburetor heat protector connecting nuts	2	6	0.7~1.1	
Exhaust pipe bolts	3	8	3.0~3.6	
Exhaust pipe connecting nuts	2	6	1.0~1.4	

TORQUE VALUES (FRAME)

ITEM	Q'TY	THREAD DIA (mm)	TORQUE VALUE(Kg-m)	REMARKS
Mounting nut for steering rod	1	25.4	1.0~2.0	
Cone seat for steering rod	1	25.4	0.2~0.3	
Front wheel shaft nut	1	12	5.0~7.0	
Rear wheel shaft nut	1	16	11.0~13.0	
Speedometer cable locking screw	1	5	0.15~0.3	
Front shock absorber mounting bolts	4	8	2.4~3.0	
Rear shock absorber upper connection bolt	1	10	3.5~4.5	
Rear shock absorber lower connection bolt	1	8	2.4~3.0	
Brake lever bolts	2	6	0.8~1.2	
Front brake hose bolts	4	10	3.3~3.7	
Front brake air-bleeding valve	1	6	0.8~1.0	
Front brake disc mounting bolts	5	8	2.8~3.2	
Front brake clipper mounting bolts	2	10	3.1~3.5	
RR.brake disc mounting bolts	5	8	2.8~3.2	
RR.caliper flange bolts	2	10	3.1~3.5	
RR.brake hose bolts	4	10	3.3~3.7	
CBS control valve mounting bolts	2	6	1.0~1.4	
Engine suspension bracket bolts	2	10	4.5~5.5	On frame side
Engine connection bolt	1	10	4.5~5.5	On engine side
Main standard nut	1	10	3.5~4.5	
Foot-starting lever bolt	1	6	1.6~1.8	
Air cleaner bolts	2	6	1.0~1.4	

The torque values listed in above table are for more important tighten torque values. Please see standard values for not listed in the table.

Standard Torque Values for Reference

TYPE	TIGHTEN TORQUE	TYPE	TIGHTEN TORQUE
5mm bolt 、nut	0.45~0.60kgf-m	3mm screw	0.05~0.08kgf-m
6mm bolt 、nut	0.80~1.20kgf-m	4mm screw	0.10~0.15kgf-m
8mm bolt 、nut	1.80~2.50kgf-m	5mm screw	0.35~0.50kgf-m
10mm bolt 、nut	3.00~4.00kgf-m	6mm screw 、SH nut	0.70~1.10kgf-m
12mm bolt 、nut	5.00~6.00kgf-m	6mm bolt 、nut	1.00~1.40kgf-m
		8mm bolt 、nut	2.40~3.00kgf-m
		10mm bolt 、nut	3.50~4.50kgf-m

Troubleshooting-EFi model

A. Engine cannot be started or difficult to be started

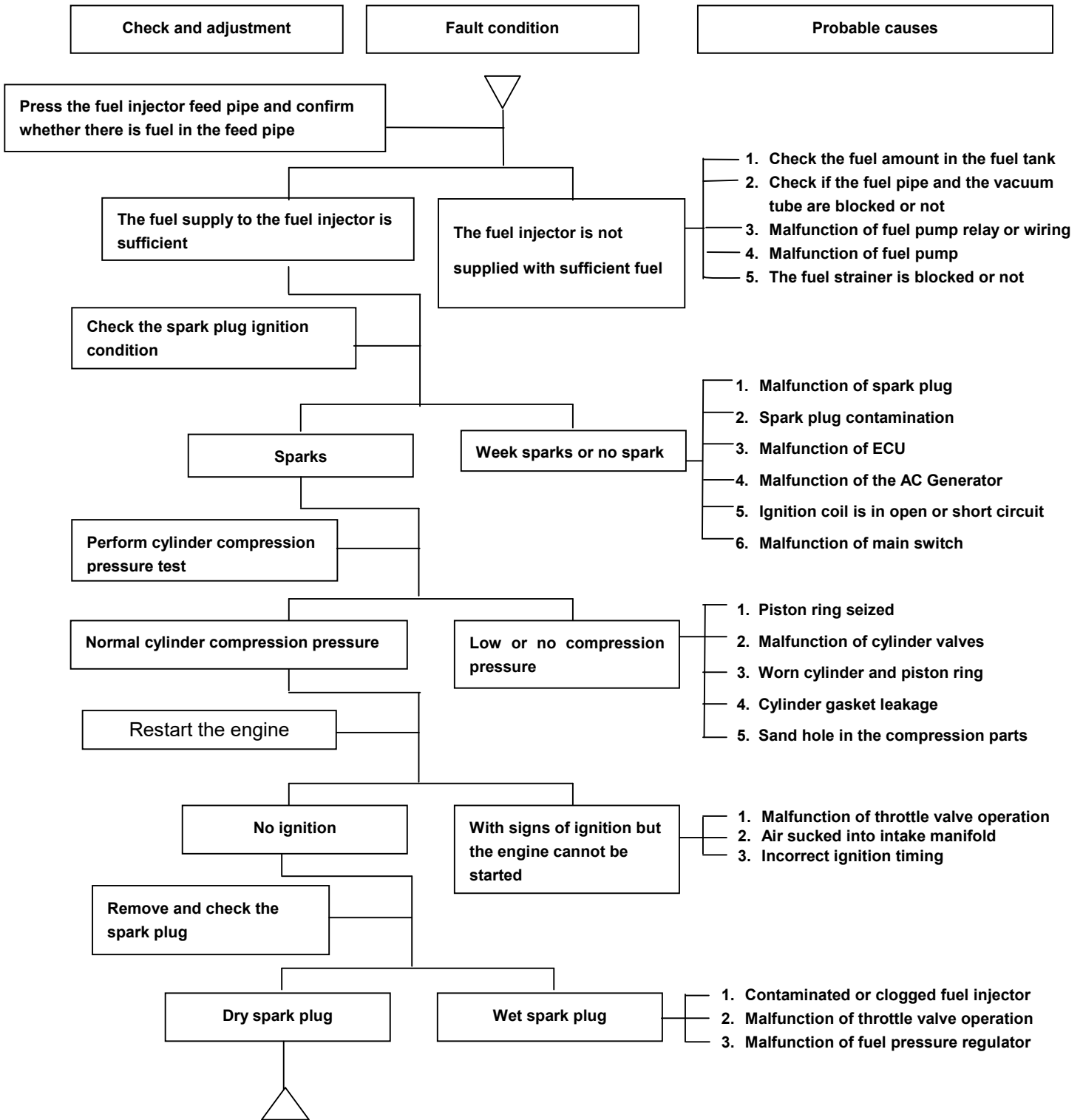

B. Engine runs sluggish (Speed does not pick up, lack of power)

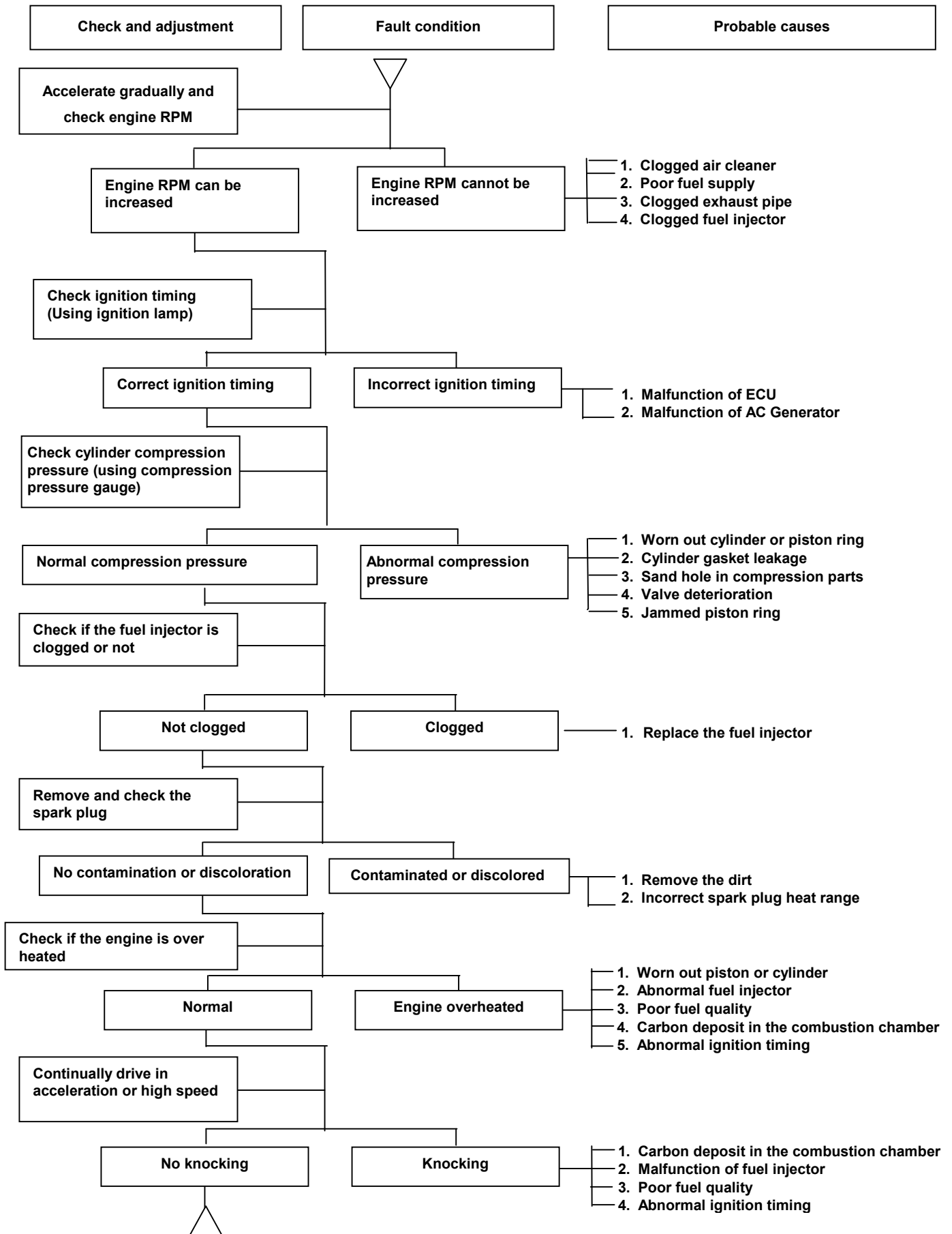

C. Engine runs sluggish (especially in low speed and idling)

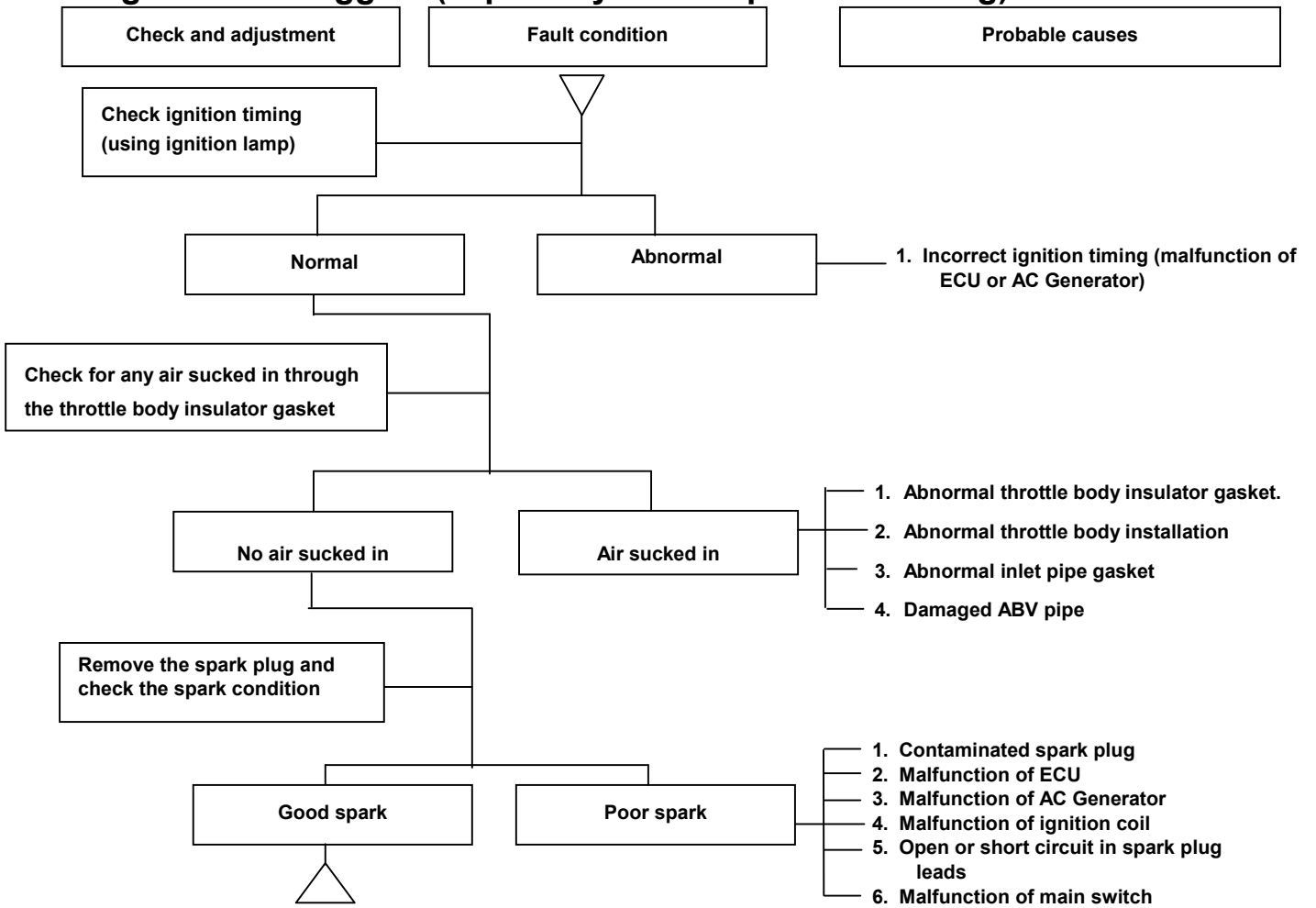

D. Engine runs sluggish (High speed)

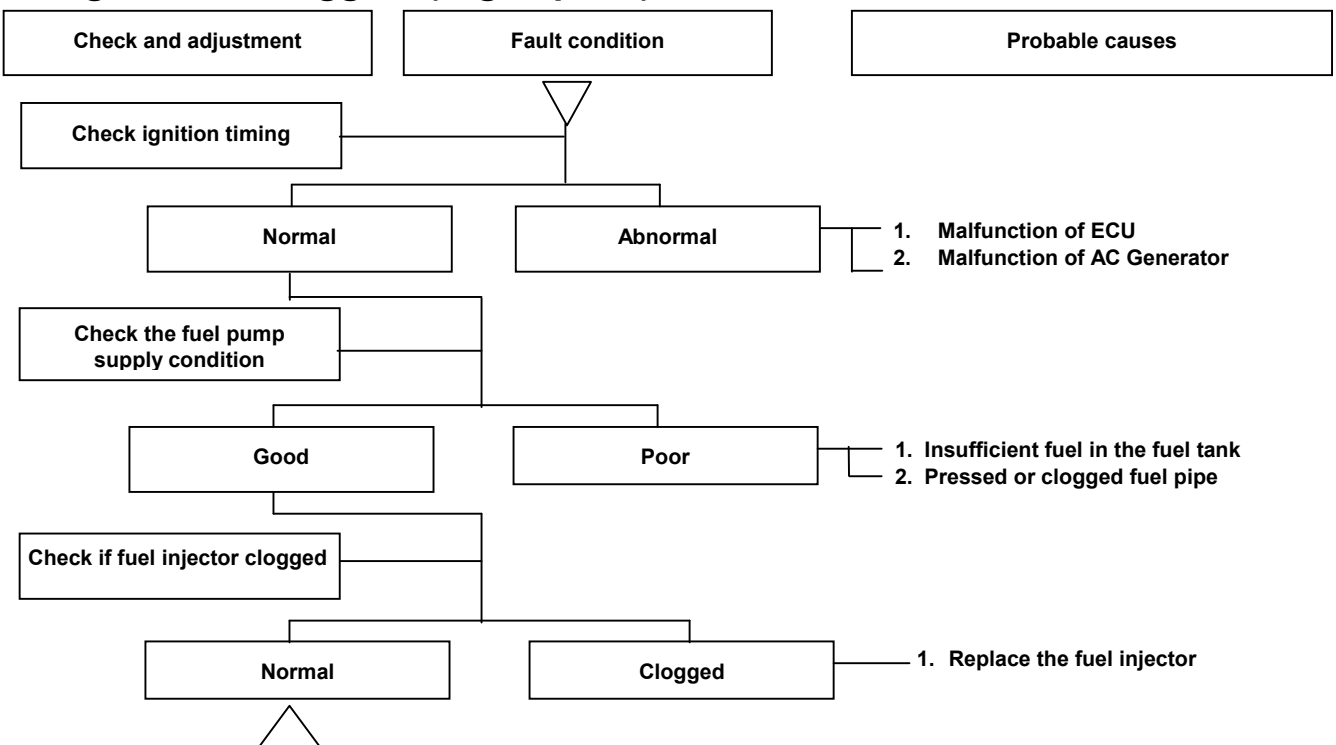

E. CLUTCH, DRIVING AND DRIVING PULLEY

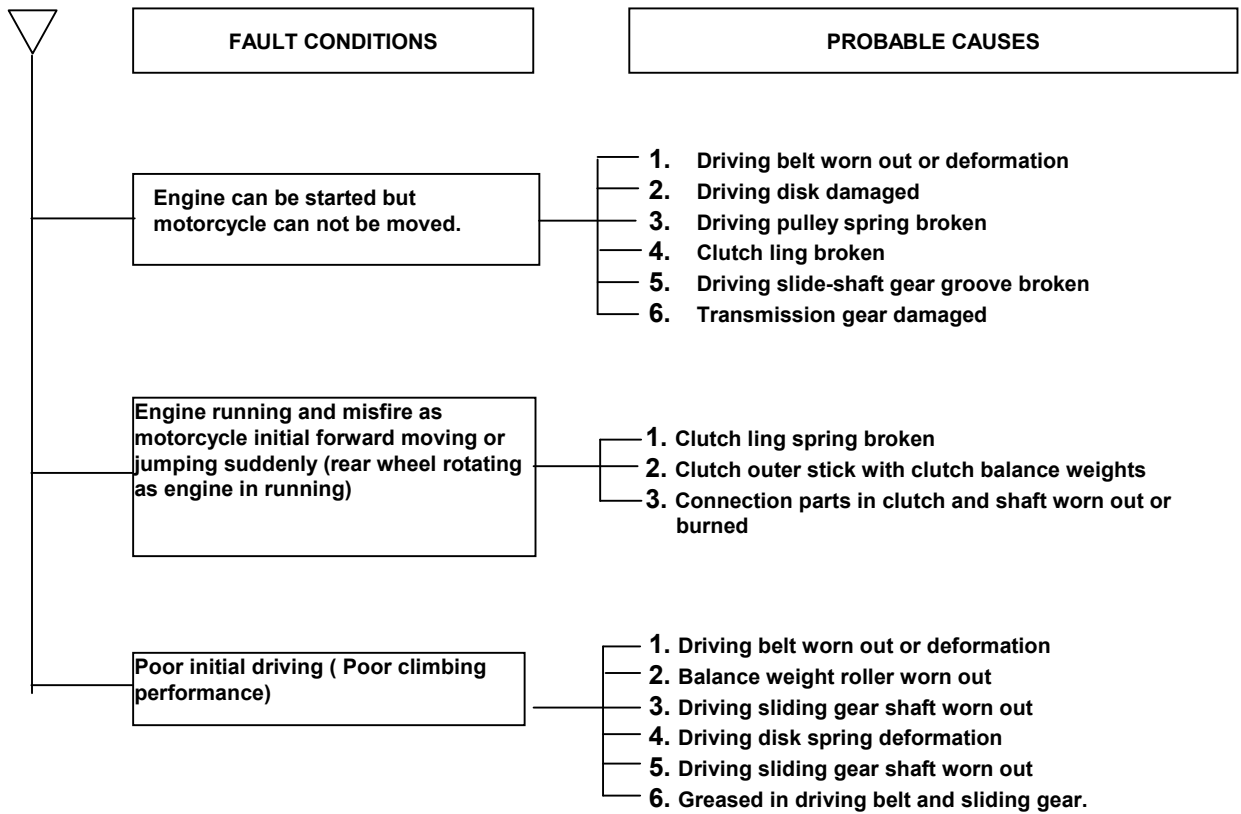

LUBRICATION POINTS

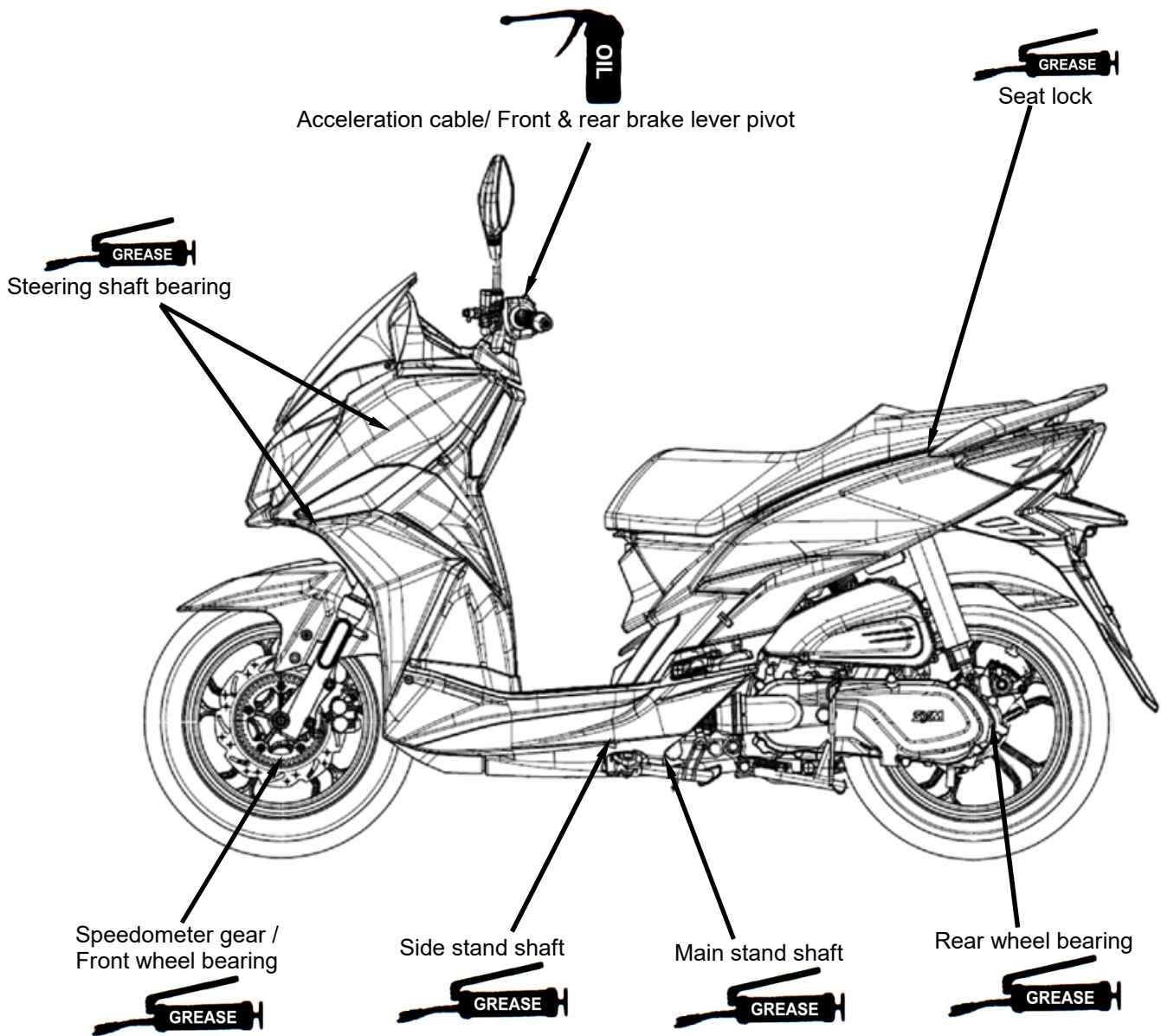

PRECAUTIONS IN OPERATION2-1	IGNITION SYSTEM/SPARK PLUG ..2-8
PERIODICAL MAINTENANCE	CYLINDER COMPRESSION
SCHEDULE2-2	PRESSURE.....2-9
LUBRICATION SYSTEM.....2-3	DRIVING SYSTEM.....2-9
FUEL SYSTEM.....2-4	STEERING SYSTEM2-10
AIR CLEANER.....2-5	SUSPENSION SYSTEM2-10
THROTTLE VALVE OPERATION2-5	FRONT DISK BRAKE SYSTEM.....2-11
CRANKCASE BLOW-BY SYSTEM2-6	DRUM BRAKE SYSTEM.....2-13
VALVE CLEARANCE INSPECTION & ADJUSTMENT2-6	WHEEL/TIRE2-14
CARBURETOR IDLING SPEED	BATTERY.....2-15
ADJUSTMENT2-7	HEADLIGHT ADJUSTMENT2-15
	NUTS、BOLTS TIGHTEN2-15

PRECAUTIONS IN OPERATION

Specification

Fuel Tank Capacity	7.50L	
Engine Oil	capacity	950 c.c.
	change	700 c.c.
Transmission Gear oil	capacity	180 c.c.
	change	170 c.c.
Clearance of throttle valve	2~6 mm	
Spark plug	CR7HSA	
“F” Mark in idling speed	Before TDC 13° / 1700 rpm	
Full timing advanced	Before TDC 27° / 8000 rpm	
Idling speed	1800±100 rpm	
Cylinder compression pressure	10.3±0.2:1 kg/cm ²	
Valve clearance: IN/EX	0.12±0.02 mm	
Tire dimension	front / rear	100/90-14 / 110/80-14
Tire pressure (cold)	single	Front: 2.00 kg/cm ² rear: 2.00 kg/cm ²
	Two persons	Front: 2.00 kg/cm ² rear: 2.25 kg/cm ²
battery	12V6Ah	

PERIODICAL MAINTENANCE SCHEDULE

Maintenance Code	Item	Initial 300KM	1 Month Every1000KM	3 month Every3000KM	6 month Every6000KM	1 year Every12000KM
1	☆Air cleaner	I		C	C	R
2	☆Fuel filter	I			I	R
3	☆Oil filter	C			C	C
4	☆Engine oil change	R	I	Replacement for every 3000km		
5	Tire pressure	I	I			
6	Battery inspection	I	I			
7	Brake & free play check	I	I			
8	Steering handle check	I	I			
9	Cushion operation check	I	I			
10	Every screw tightening check	I	I			
11	Gear oil check for leaking	I	I			
12	☆Spark plug check or change	I		I	R	
13	☆Gear oil change	R	Replacement for every 5000km			
14	Frame lubrication				L	
15	Exhaust pipe	I	I			
16	☆Ignition timing	I	I			
17	☆Emission check in Idling	A	I			
18	☆Throttle operation	I		I		
19	☆Engine bolt tightening	I		I		
20	☆CVT driving device (belt)				I	R
21	☆CVT driving device (roller)				C	
22	Lights/electrical equipment/multi-meters	I	I			
23	Main/side stands & springs	I			I	
24	Fuel pipes	I		I		
25	Cam chain	I		I		
26	☆Valve clearance	I		A		
27	☆Crankcase blow-by over-flow pipe	I	Replacement for every 2000km			

Code: I ~ Inspection, cleaning, and adjustment R ~ Replacement C ~ Cleaning (replaced if necessary) L ~ Lubrication

Have your motorcycle checked, adjusted, and recorded maintenance data periodically by your SYM Authorized Dealer to maintain the motorcycle at the optimum condition

The above maintenance schedule is established by taking the monthly 1000 kilometers as a reference which ever comes first.

Remarks:

1. These marks “☆” in the schedule are emission control items. According to EPA regulations, these items must be perform normally periodical maintenance following the use r manual instructions. They are prohibited to be adjusted or repaired by unauthorized people. Otherwise, SYM is no responsible for the charge.
2. Clean or replace the air cleaner element more often when the motorcycle is operated on dusty roads or in the Heavily- polluted environment.
3. Maintenance should be performed more often if the motorcycle is frequently operated in high speed and after the motorcycle has accumulated a higher mileage.
4. Preventive maintenance
 - a. Ignition system - Perform maintenance and check when continuous abnormal ignition, misfire, after-burn, overheating occur.
 - b. Carbon deposit removal - Remove carbon deposits in cylinder head, piston heads, exhaust system when power is obvious lower than ever.
 - c. Replace worn out pistons, cylinder head.

LUBRICATION SYSTEM

Engine Oil Capacity

⚠ Caution

- The vehicle must be parked on a level ground when checking oil capacity.
- Run the engine for 2-3 minutes then stop, wait about 2-3 more minutes allowing engine oil to settle before checking the oil level.

Remove dipstick to check the oil level. If oil level is below the lower limit mark, add oil to the specified upper limit mark.

Oil change

Shut off the engine and remove dipstick. Remove the oil drain plug on the bottom-left of crankcase to drain oil. After draining out oil, clean oil plug and its gasket and reinstall. Replace the gasket if it is damaged.

Torque value: 3.5~4.5 kgf-m

⚠ Caution

Warm up the engine. This will make the oil flow out easily.

Add oil to the specified capacity.

Oil Viscosity: SAE 10W-30, recommended using King-Mate serial oil.

Engine oil capacity:

Disassembly: 950cc

Change: 700cc

When checking for oil leak, run the engine at idle speed for a few minutes, then check oil capacity with dipstick.

Cleaning the oil strainer

Drain oil from engine, remove the strainer cover, spring and strainer. If there is an accumulation on the screen, wash it off with suitable solvent (recommended using compressed air). Check O-ring for damage, replace if necessary. Reinstall strainer, spring, O-ring and strainer cover.

Torque value: 1.3~1.7 kgf-m

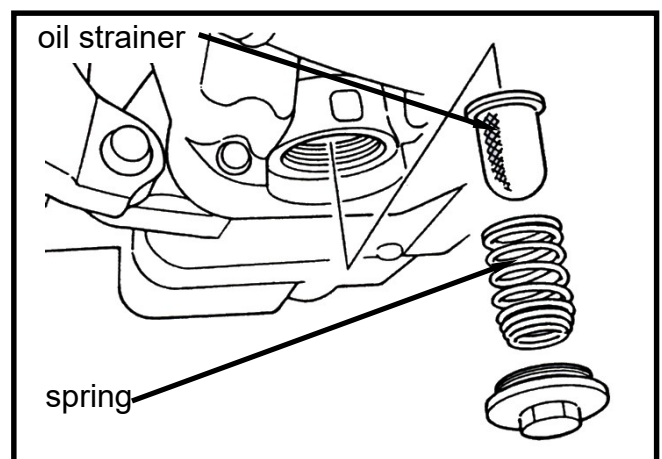
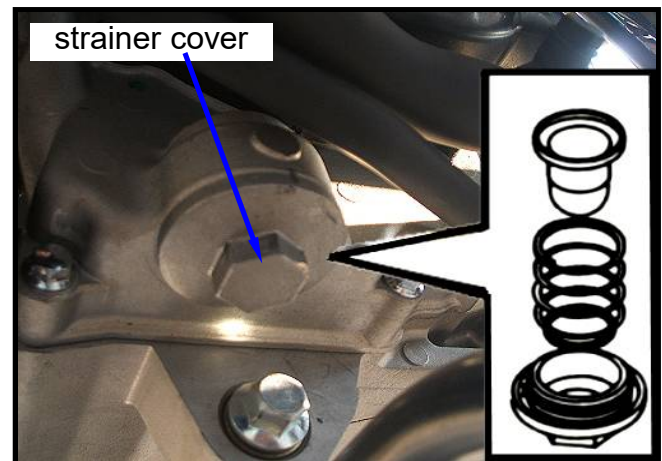
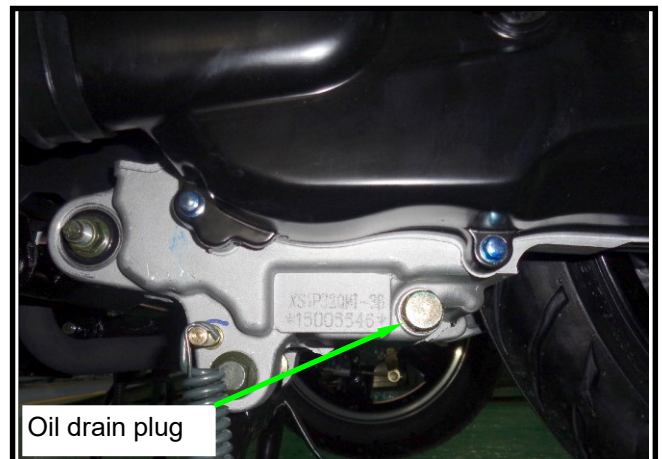
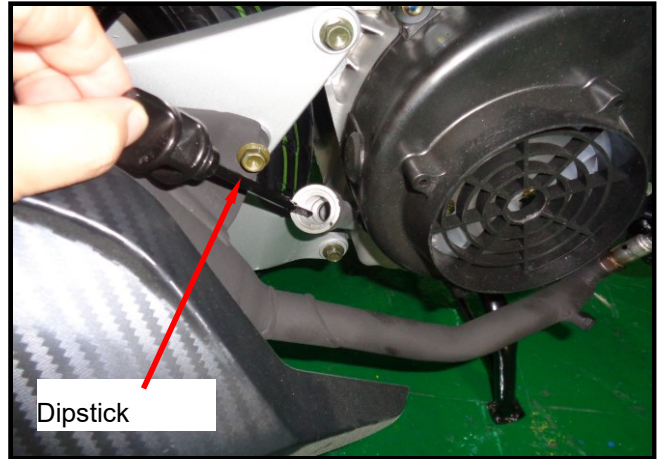

Gear Oil

Inspection

Check gear oil if leaking.
Park the motorcycle with main stand on flat level place.
Turn off engine and remove the gear oil draining plug.
Place a measurement cup under the draining hole.
Remove the oil drain plug and drain gear oil into a measurement cup.
Check gear oil if enough.

Replacement

At first, remove the gear oil refilling bolt, and then remove the draining plug.
Install the draining plug after drained oil out.

Torque value: 0.8~1.2 kgf-m

Caution

Inspect if washer is in good condition.
Replace it with new one if it was deformed or damaged.

Fill out gear oil to specified quantity from the engine oil filling hole.
Install the oil filling bolt.

Torque value: 0.8~1.2 kgf-m

Transmission oil capacity: 180 c.c.(170 c.c. for change)

Recommended: genuine SYM HYPOID gear oil (SAE 85W-140).

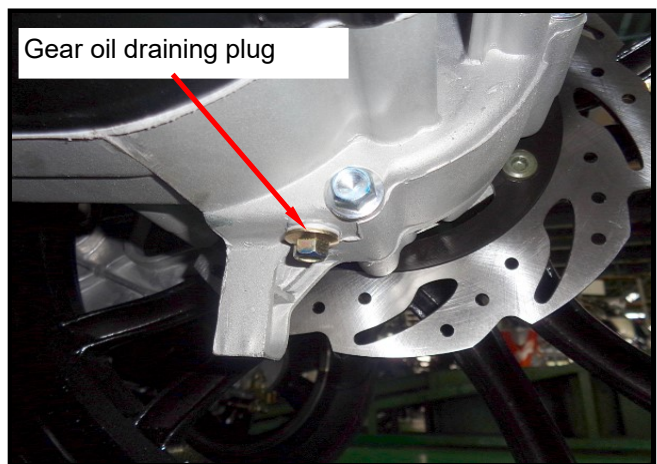
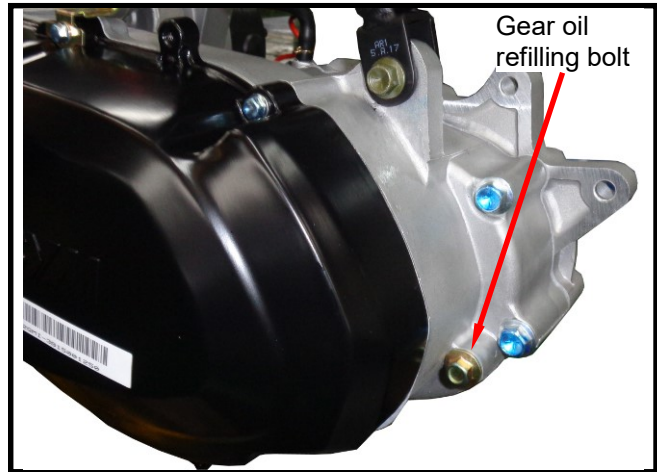

Fuel System

Fuel Pipe

Remove luggage box, side cover, center cover, body frame cover, and pedal, as well as front inner box.
Check all pipes, and replace it when they are deterioration, damage or leaking.

Warning

Gasoline is a low ignition material so any kind of fire is strictly prohibited as dealing it.

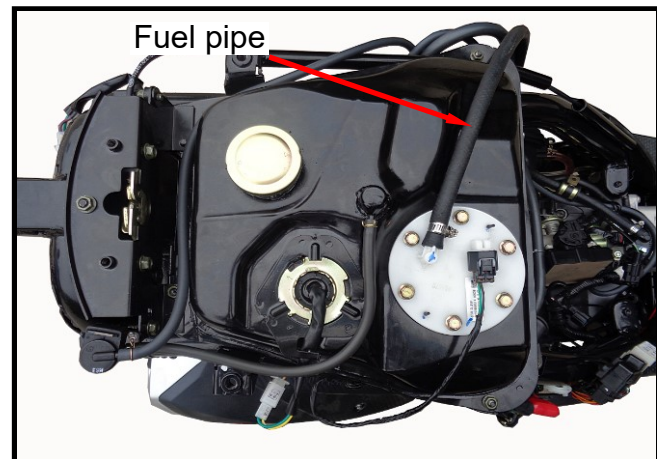

AIR CLEANER

Element

Remove left side cover.
 Remove 9 screws from the air cleaner cover.
 Remove element of air cleaner (2 bolts).
 Check the element if dirt or damaged.
 Replace it with new one if dirt or damaged.

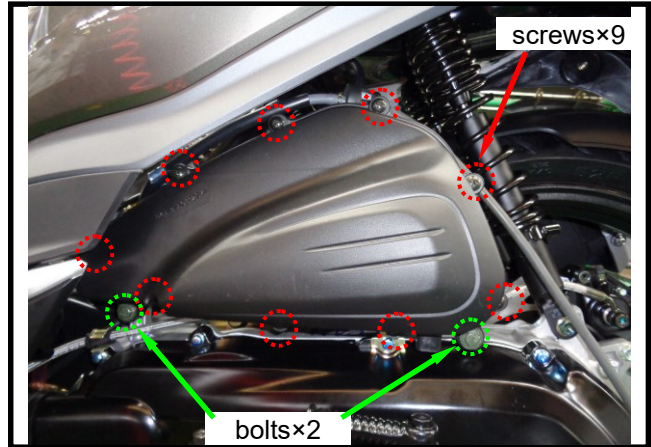

⚠ Caution

- Air cleaner element contains a paper made filter so do not try to clean it.
- Make sure that the air cleaner cover had been installed properly after installation.



THROTTLE VALVE OPERATION

Have a wide open of throttle valve as handle bar in any position and release it to let back original (full closed) position.
 Check handle bar if its operation is smooth.
 Check throttle valve cable and replace it if deteriorated, twisted or damaged.
 Lubricate the cable if operation is not smooth.

Measure handle bar free play in its flange part.

Free play : 2~6 mm

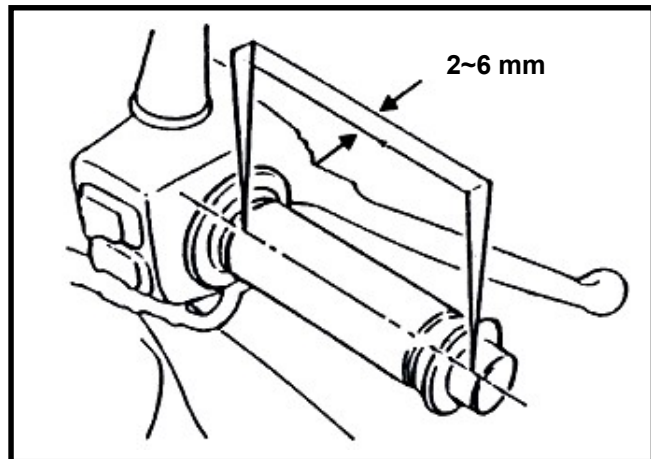

Adjustment can be done in either ends.
 Secondary adjustment is conducted from top side.

Remove rubber boot, loosen fixing nut, and then adjust it by turning the adjustment nut.

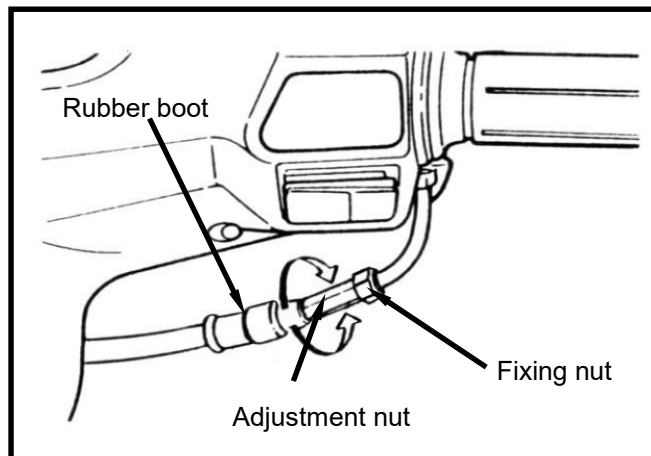

Primary adjustment is conducted from button side.

Loosen fixing nut, and adjust by turning the adjustment nut.

Tighten the fixing nut, and check acceleration operation condition.

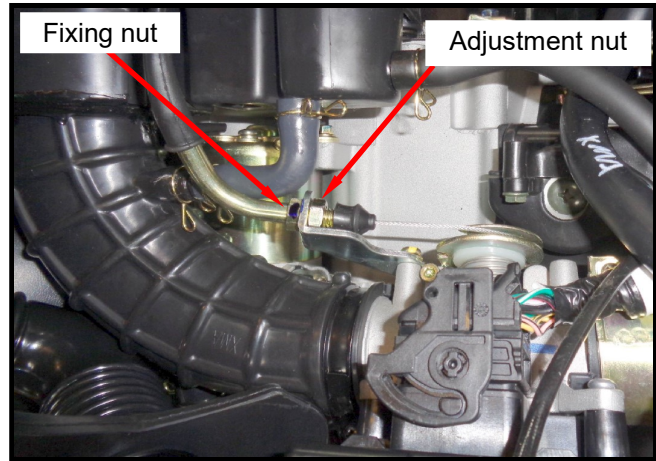

CRANKCASE VENTILATION

Pull out the plug from draining hose to clean deposits

Caution

When always riding in rainy area or full throttle position, maintenance period must be shortened. The deposits can be seen in the transparent section of draining hose.

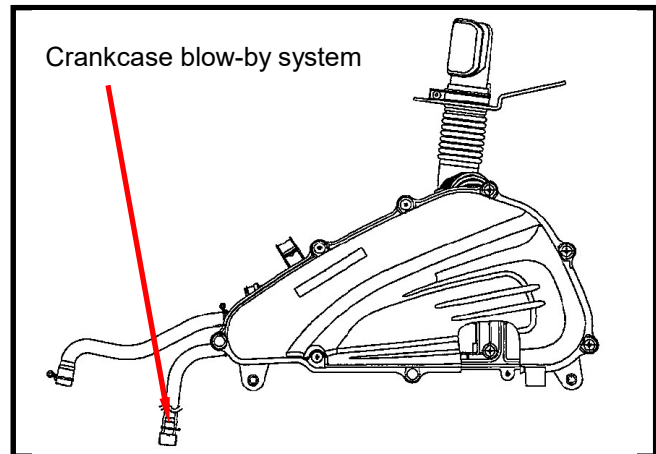

VALVE CLEARANCE INSPECTION AND ADJUSTMENT

⚠ Caution

Checks and adjustment must be performed when engine is cold (below 35°C).

Remove luggage box and front center cover.
Remove the left body cover & left side cover.
Remove cylinder head cap.

Remove the ignition timing check hole on the cooling fan cover.

With "T" type wrench, turn crankshaft in clockwise motion so that mark ("T") on the generator flywheel aligns with the mark on the crankshaft, and camshaft is at TDC position also as same as level of cylinder head top-end. A single hole on camshaft sprocket is forward to up. (Piston is at TDC position in the compression stroke.)

⚠ Caution

The crankshaft can not be rotated in counter-clockwise to prevent from damage so that valve clearance can not be measured.

Check & adjust valve clearance with feeler gauge.

Valve clearance (IN/EX):
0.12±0.02 mm/0.12±0.02 mm

Loosen fixing nut and turn the adjustment nut for adjustment.

⚠ Caution

It has to make sure that valve-rocker arm is be adjusted to standard level when adjusting it, and re-check the valve clearance after tightened the fixing nut.

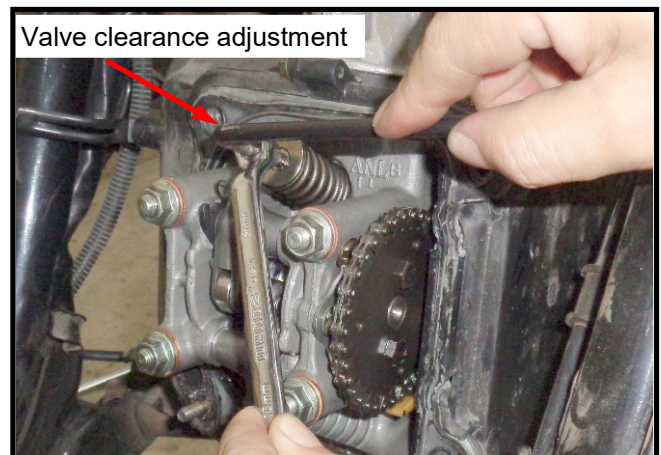
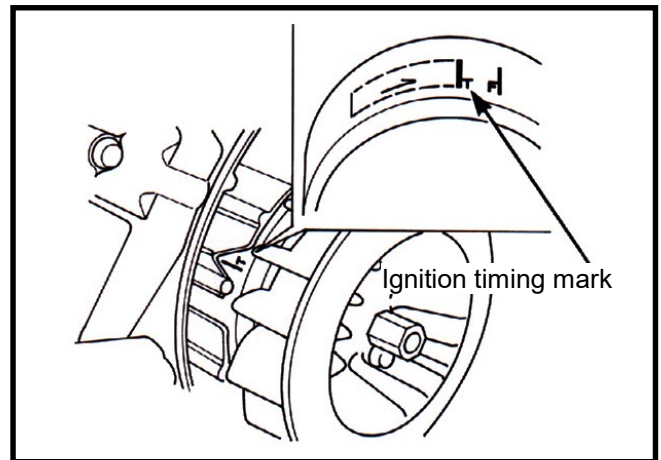
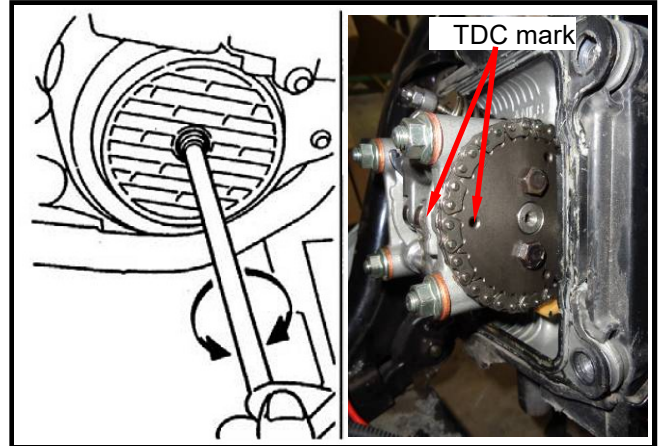

SPARK PLUG

Appointed spark plug: CR7HSA

Remove luggage box.

Remove body side cover.

Remove front center cover.

Remove spark plug cap.

Clean dirt around the spark plug hole.

Remove spark plug.

Measure spark plug gap.

Spark plug gap: 0.6~0.7 mm

Carefully bend ground electrode of the plug to adjust the gap if necessary.

Screw the park plug into the plug hole with hands, then tighten the plug with a wrench to prevent from damaging the spark plug's thread.

Torque value: 1.0~1.2 kgf-m

Connect spark plug cap.

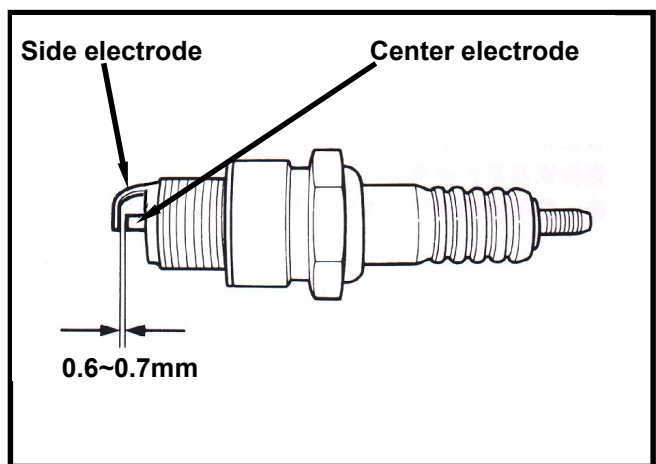
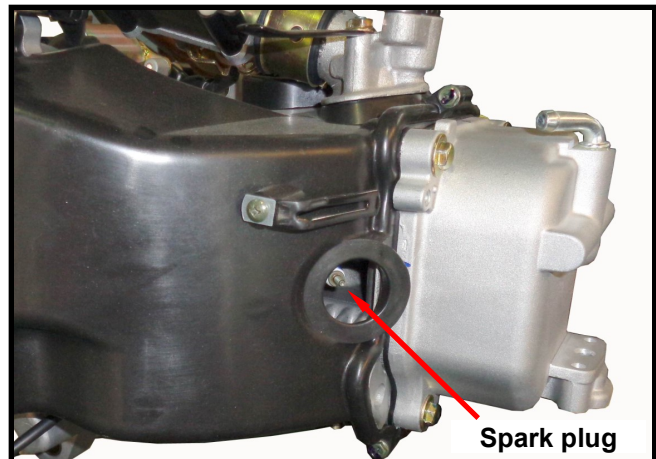

CYLINDER COPMRESSION PRESSURE

Warm up engine and then turnoff the engine.
 Open the seat. Remove the luggage box.
 Remove spark plug cap and spark plug.
 Install compression gauge.
 Full open the throttle valve, and rotate the engine by means of stepping the kick-starting lever.

⚠ Caution

Rotate the engine until the reading in the gauge no more increasing.
 Usually, the highest pressure reading will be obtained in 4~7 seconds by electric start engine.

Compression pressure: 10.3±0.2:1 Kg/cm²

Check following items if the pressure is too low:

- Incorrect valve clearance
- Valve leaking
- Cylinder head leaking, piston, piston ring and cylinder worn out

If the pressure is too high, it means carbon deposits in combustion chamber or piston head.

DRIVING SYSTEM

DRIVING BELT

Remove left side cover.
 Remove mounting bolt located under air cleaner.
 Remove 9 bolts of the engine left crankcase.
 Remove the left crankcase cover.
 Check if the belt is crack or worn out.
 Replace the belt if necessary or in accord with the periodical maintenance schedule to replace it.

Width limit: above 17.5 mm

Clutch pad

Start the motorcycle and gradually increase throttle valve openness to check clutch pad operation.
 If the motorcycle moves with shaking, then check its clutch pad for wearing. Replace it if necessary.

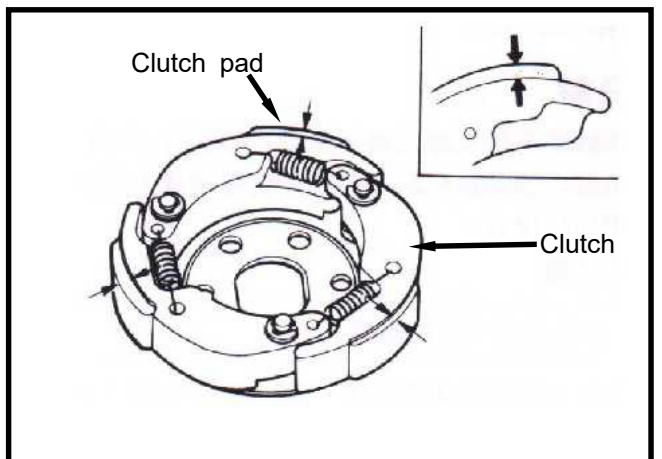
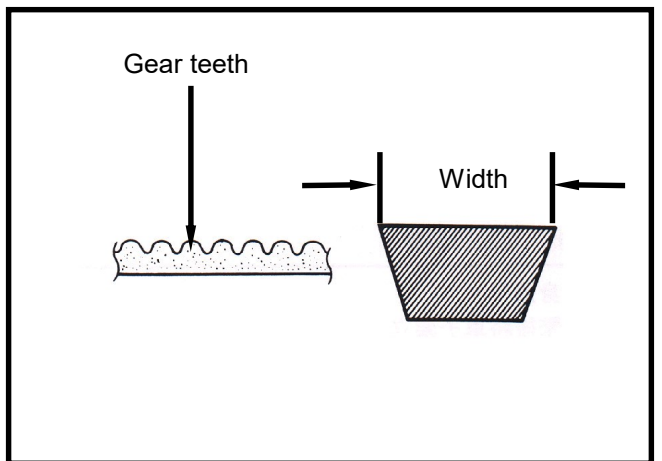
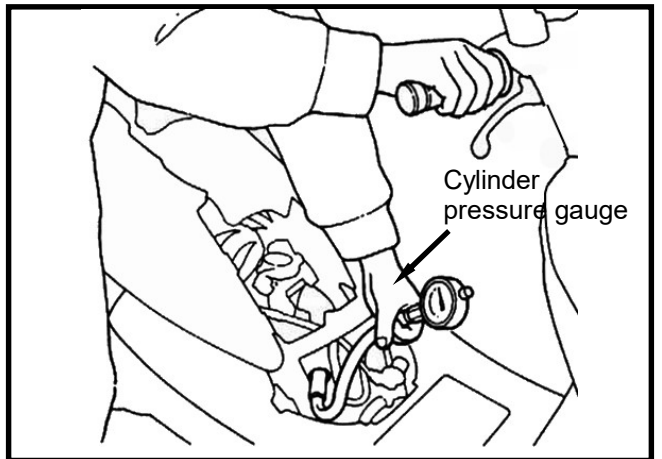
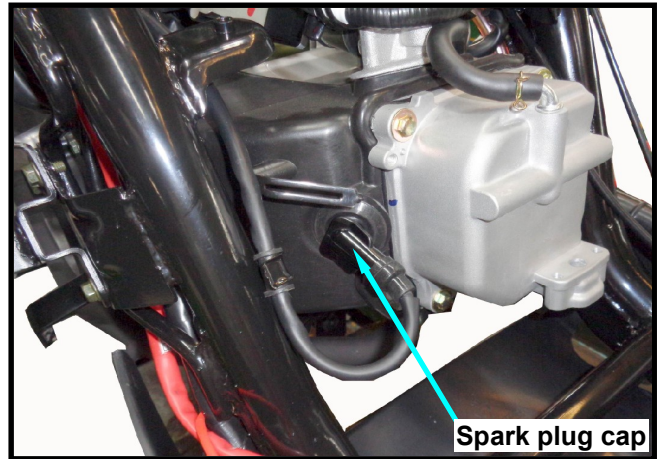

STEERING SYSTEM

⚠ Caution

Check all wires and cables if they are interfered with the rotation of steering handle bar.

Lift the front wheel out of ground.
Turn handle from right to left and check if turning is smoothly.
If handle turning is uneven and bending, or the handle can be operated in vertical direction, then adjust the handle top bearing.

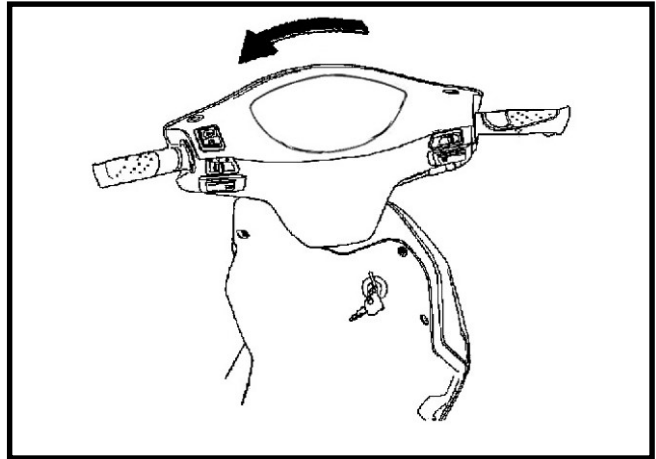

SUSPENSION SYSTEM

⚠ Warning

- Do not ride the motorcycle with poor shock absorber.
- Looseness, wear or damage shock absorber will make poor stability and drivability.

Front shock absorber

Hold front brake lever and press down the front shock absorber for several times to check its operation.
Hold front brake lever and push forward the front shock absorber for several times to check its locking status.
Check if it is scratched or leaking.
Replace damaged and non-repairable components.
Tighten all nuts and bolts.

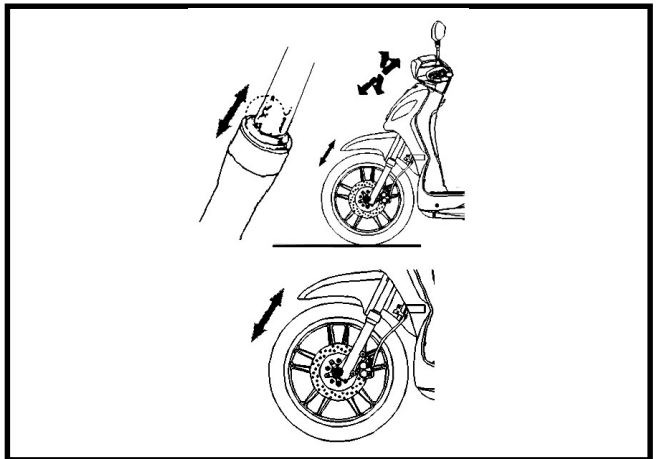

Rear Shock absorber

Press down the rear shock absorber for several times to check its operation.
Check if it is scratched or leaking.
Replace damaged and non-repairable components.
Park the motorcycle with main stand.
Start engine and let the rear wheel rotate after increased engine rpm. Check engine for any parts loose or shaking. Also check the engine suspension bushing for wear out.
Replace the bushing if worn out.
Tighten all nuts and bolts.



FRONT DISK BRAKE SYSTEM

BRAKE SYSTEM HOSE

Make sure the brake hoses for corrosion or leaking oil, and also check brake system for leaking.

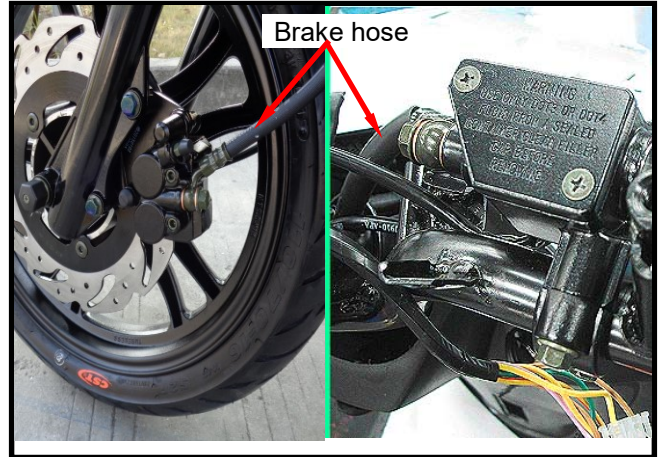

BRAKE FLUID

Check brake fluid level in the brake fluid reservoir. If the level is lower than the LOWER limit, add brake fluid to UPPER limit. Also check brake system for leaking if low brake level found.

⚠ Caution

- In order to maintain brake fluid in the reservoir in horizontal position, do not remove the cap until handle bar stop.
- Do not operate the brake lever after the cap had been removed. Otherwise, the brake fluid will spread out if operated the lever.
- Do not mix non-compatible brake fluid together.

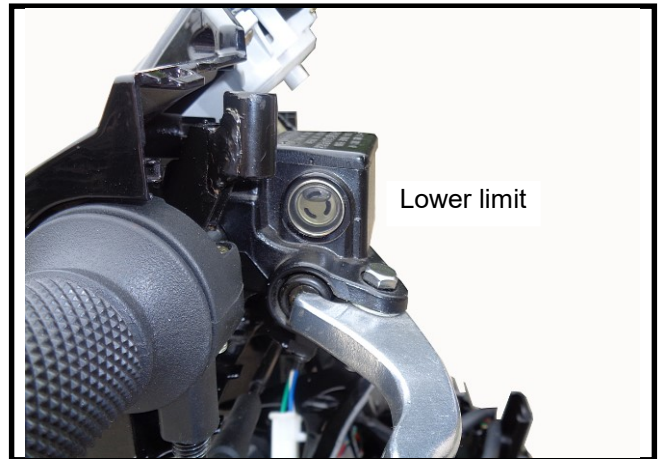

FILLING OUT BRAKE FLUID

Tighten the drain valve, and add brake fluid. Place the diaphragm in. Operate the brake lever so that brake fluid contents inside the brake system hoses.

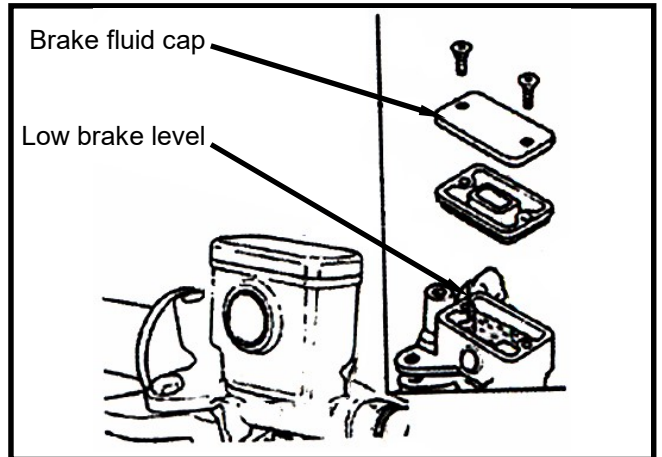

AIR BLEED OPERATION

Connect a transparent hose to draining valve. Hold the brake lever and open air bleeding valve. Perform this operation alternative until there is no air inside the brake system hoses.

⚠ Caution

Before closing the air bleed valve, do not release the brake lever.

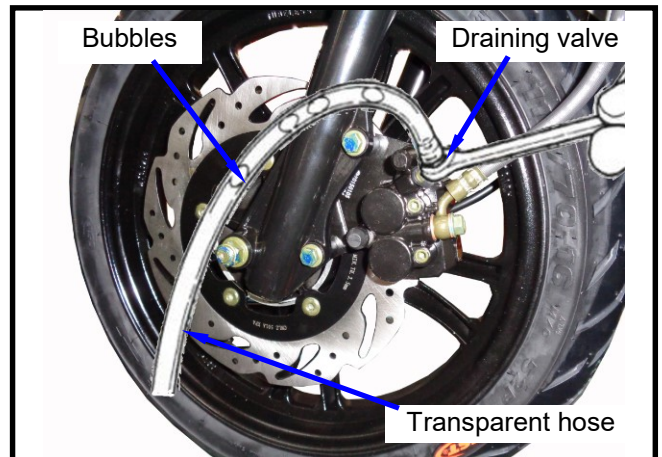

ADDED BRAKE FLUID

Add brake fluid to UPPER limit lever.
Recommended brake fluid: DOT3 or DOT4
WELL RUN brake fluid.

⚠ Caution

Never mix or use dirty brake fluid to prevent from damage brake system or reducing brake performance.

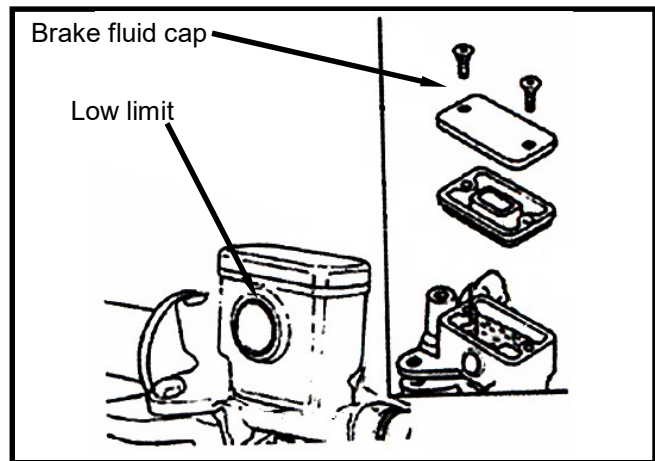

BRAKE LINING WEAR

The indent mark on brake lining is the wear limitation.
Replace the brake lining if the wear limit mark closed to the edge of brake disc.

⚠ Caution

It is not necessary to remove brake hose when replacing the brake lining.

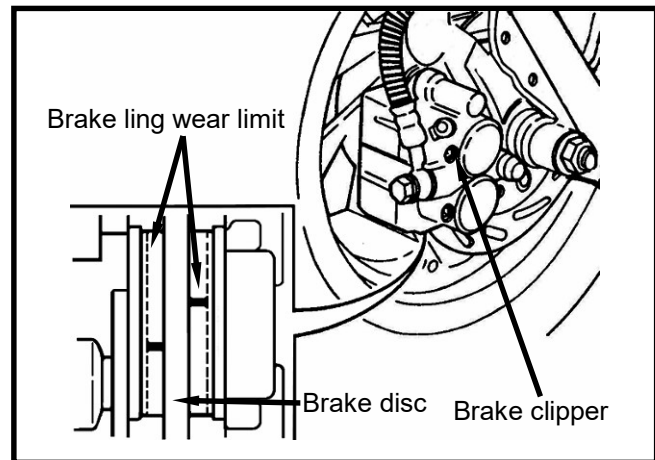

Remove the brake clipper bolt, and take out the clipper.

⚠ Caution

Do not operate the brake lever after the clipper removed to avoid clipping the brake lining.



Pry out the brake lining with a flat driver if lining be clipped.

Remove brake lining bolt.
Take out the lining.

⚠ Caution

In order to maintain brake power balance, the brake lining must be replaced with one set.

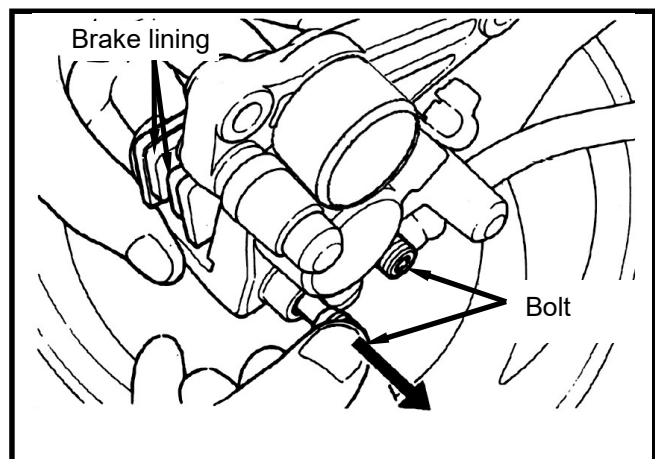

ABS (Anti-lock Brake System)

ABS is designed to help prevent the wheel from locking up when hard brakes are applied while running straight. The ABS automatically regulates the brake force. Intermittently gaining gripping force and braking force helps prevent wheel lock-up and allows stable steering control while stopping. Brake control function is identical to that of a conventional scooter. The right brake lever is used for the front brake and the left brake lever for the rear brake.

Use of non-recommended tires may cause malfunctioning of ABS and can lead to extended braking distance. The rider could have an accident as a result. Always use recommended standard tires for this scooter.

When the ABS is functioning, rider may feel a pulsing in the brake lever. This is normal. ABS does not function at the speed of approx. 5 km/h or below. ABS does not function if the battery is discharged.

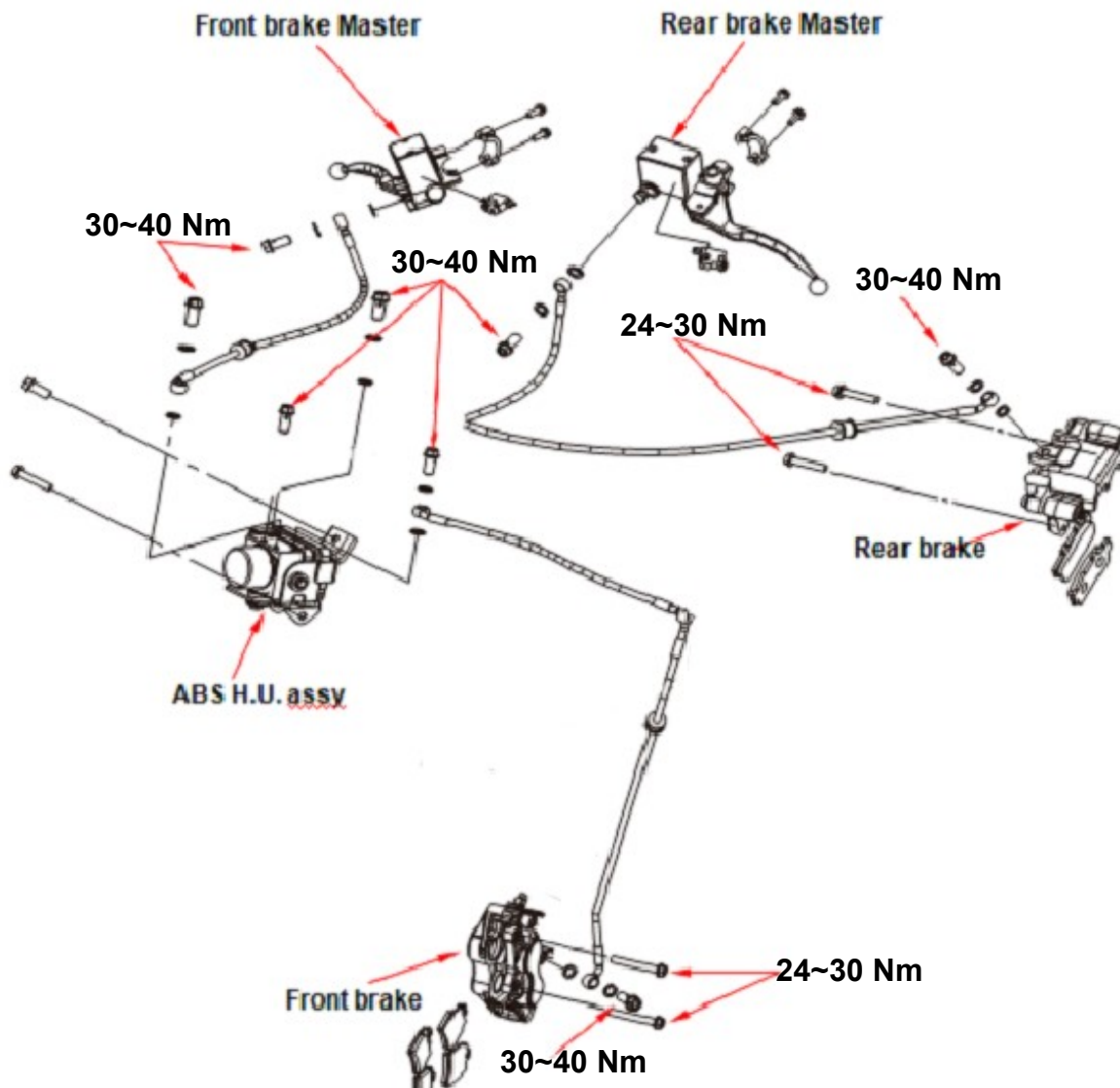

BRAKE LIGHT SWITCH

The brake light switch is to lit up brake light as brake applied.

Make sure that electrical starter can be operated only under brake applying.

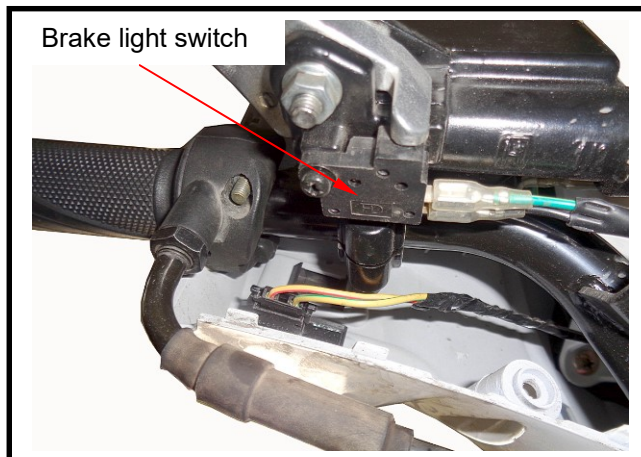

WHEEL/TIRE

Check if both front and rear tire pressure are within specification.

Caution

Tire pressure check should be done as cold tire.

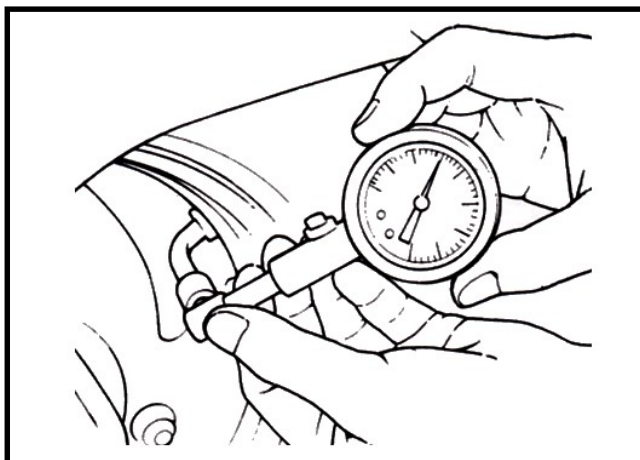

Appointed tire pressure

Tire size		Front tire	Rear tire
Tire pressure as cold (Kg/cm ²)	Load for single	2.00	2.00
	Load for two persons	2.00	2.25

Appointed Tire

Front wheel: 100/90-14

Rear wheel: 110/80-14

Check if tire surface is ticked with nails, stones or other materials.

Check if tire surface or wall for crack or damaged, and replace it if necessary.

The tire tread depth can be checked by visual inspection or depth gauge.

- Replace the tire if tire tread dent or unusual wearing out.
- The tire should be replaced if the wear limit mark (Δ) is in visible.

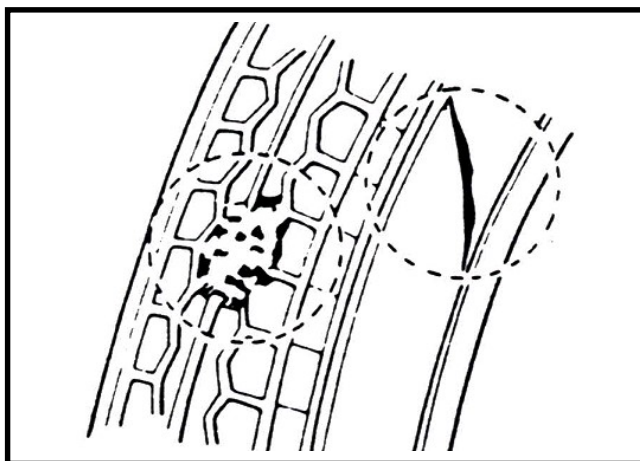

Measure tire thread depth from tire center surface.

Replace the tire if the depth is not come with following specification:

Front tire: 1.5 mm

Rear tire: 2.0 mm

Caution

The wear limit marks (Δ) are located around the tire wall even for inspection.

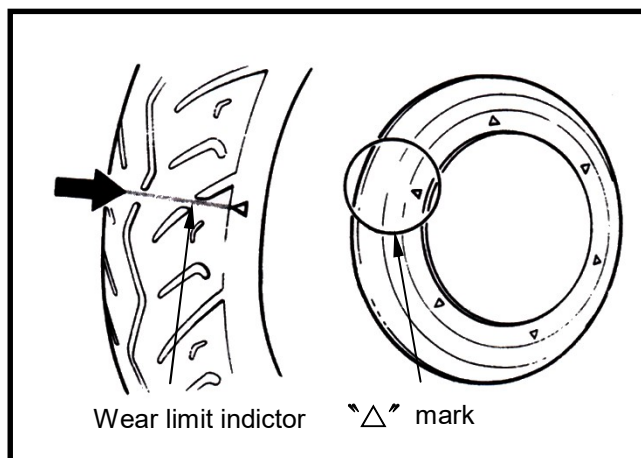

BATTERY

Battery Removal

Remove the 2 screws on the floor panel.
Remove battery cap. (2 nuts)

Battery cables removal:

1. At first, remove the negative “-” cable.
2. Then, remove the positive “+” cable.
3. Remove the battery.

If there is some rust on battery posts, clean it with steel brush.

Install the battery in the reverse procedures of removal.

⚠ Caution

- If there is rust on the posts very serious, spray some hot water on the posts. Then, clean it with steel brush so that can remove rust for more easily.
- Apply some grease on the posts after rust removed to prevent from rust again.

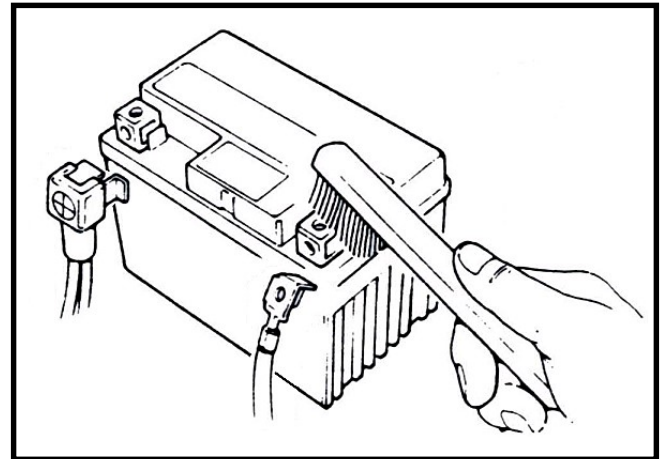
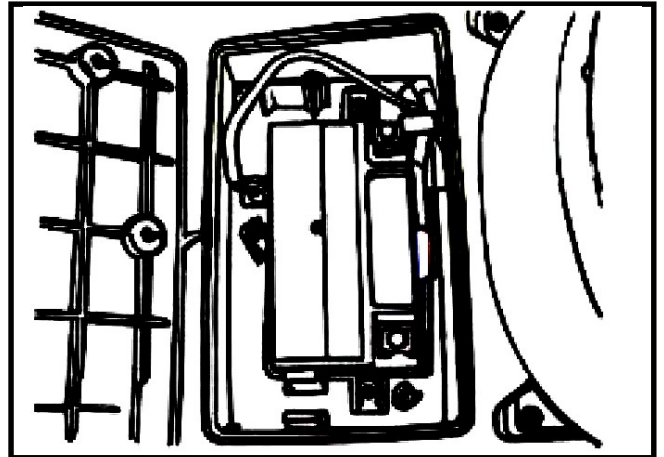

HEADLIGHT ADJUSTMENT

Park the motorcycle with the main stand.

Remove the front cover.

Turn on the main switch.

Turn the headlight adjustment screw. And adjust the headlight beam height.

Then, tighten the adjustment screw after the beam height in proper position.

⚠ Caution

- To adjust the headlight beam follows related regulations.
- Improper headlight beam adjustment will make in coming driver dazzled or insufficient lighting.

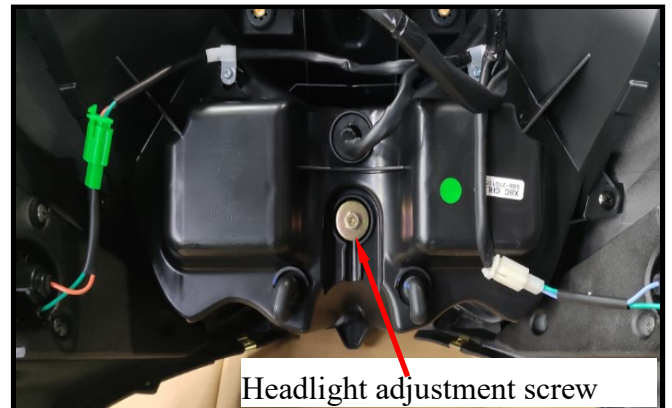

NUTS, BOLTS TIGHTENESS

Perform periodical maintenance in accord with the Periodical Maintenance Schedule.
Check if all bolts and nuts on the frame are tightened securely.

Check all fixing pins, snap rings, hose (pipe) clamps, and wire holders for security.

MECHANISM DIAGRAM3-1	CLEANING ENGINE OIL STRAINER...3-3
OPERATIONAL PRECAUTIONS3-2	OIL PUMP3-4
TROUBLE DIAGNOSIS.....3-2	GEAR OIL3-6
ENGINE OIL3-3	

MECHANISM DIAGRAM

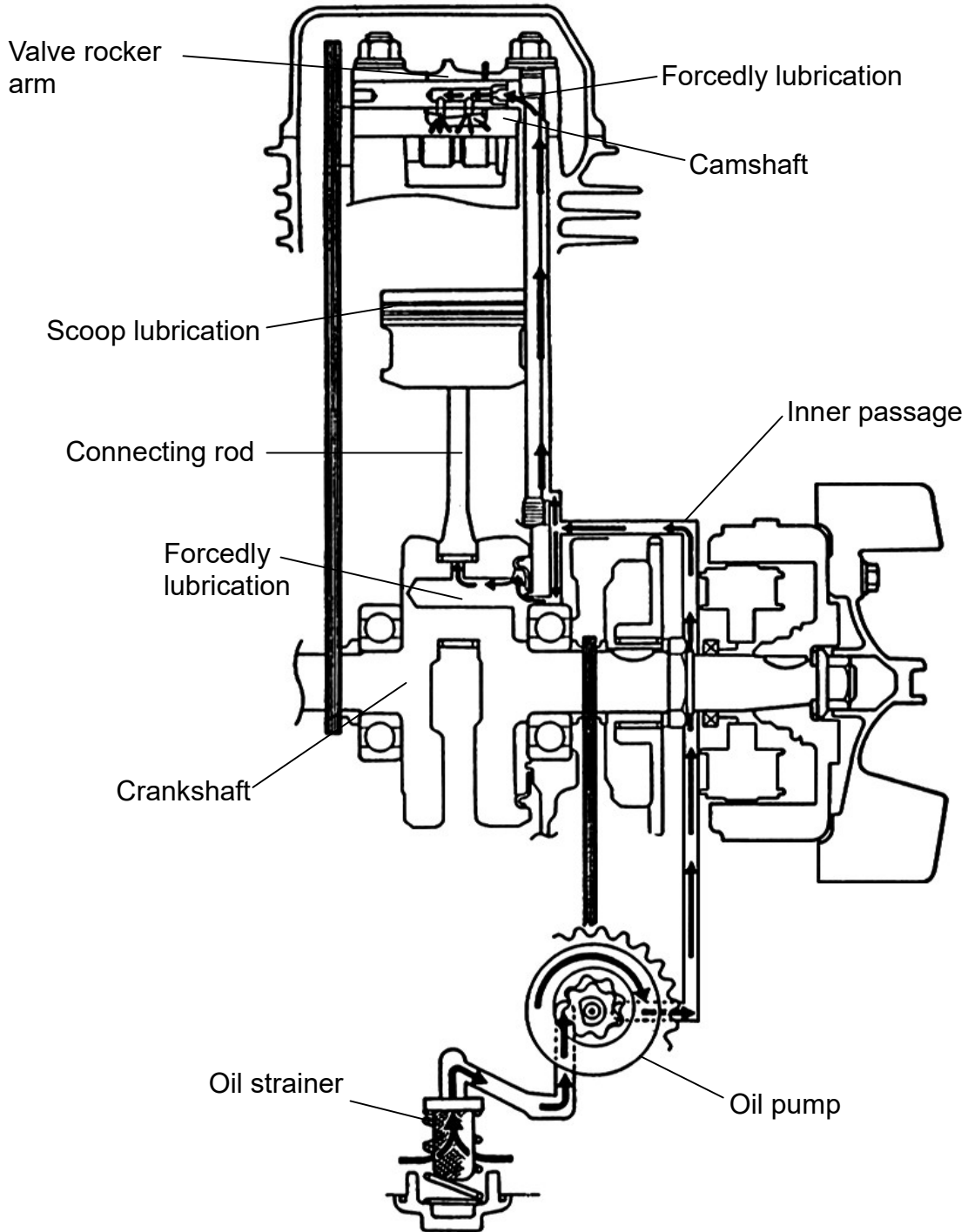

OPERATIONAL PRECAUTIONS

General Information

- This chapter contains maintenance operations for the engine oil pump, engine oil and gear oil.

Specifications

Engine oil quantity	Disassembly 950 c.c. Replacement 700 c.c.
Oil viscosity	SAE 10W-30 or equivalent
Gear Oil Capacity	Disassembly 180 c.c. Replacement 170 c.c.
Oil viscosity of gear oil	SAE 85W-140

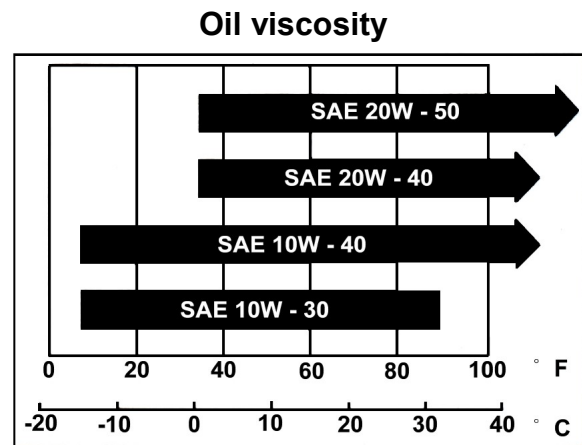

unit : mm

Items		Standard	Limit
Oil pump	Inner rotor clearance	-	0.12
	Clearance between outer rotor and body	-	0.12
	Clearance between rotor side and body	0.05~0.10	0.20

Torque value

Engine oil drain plug	3.5~4.5kgf-m
Engine oil screen cover	1.0~2.0kgf-m
Gear oil drain bolt	1.0~1.5kgf-m
Gear oil filling bolt	1.0~1.5kgf-m
Oil pump drive sprocket nut	0.8~1.2kgf-m

TROUBLE DIAGNOSIS

Low engine oil level

- Oil leaking
- Valve guide or seat worn out
- Piston ring worn out

Low Oil Pressure

- Low engine oil level
- Clogged in oil strainer, circuits or pipes
- Oil pump damage

Dirty oil

- No oil change in periodical
- Cylinder head gasket damage
- Piston ring worn out

ENGINE OIL

Turn off engine, and park the motorcycle in flat ground with main stand.

Check oil level with oil dipstick after 3-5 minutes.

Do not rotate the dipstick into engine as checking.

If oil level is nearly low level, fill out recommended oil to upper level.

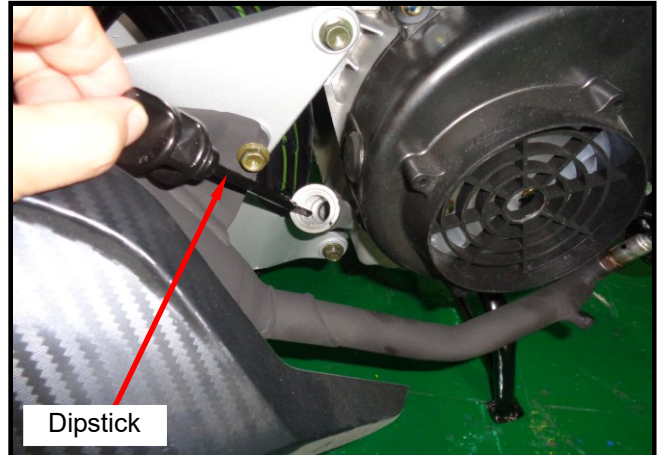

Dipstick

Oil Replacement**⚠ Caution**

Drain oil as engine warmed up so that make sure oil can be drained smoothly and completely.

Place an oil pan under the motorcycle, and remove oil strainer cap.

Make sure if the aluminum washer of the draining bolt is damaged. If so, replace it with new one.

Install the oil drain plug and tighten it.

Torque value: 3.5~4.5 kgf-m

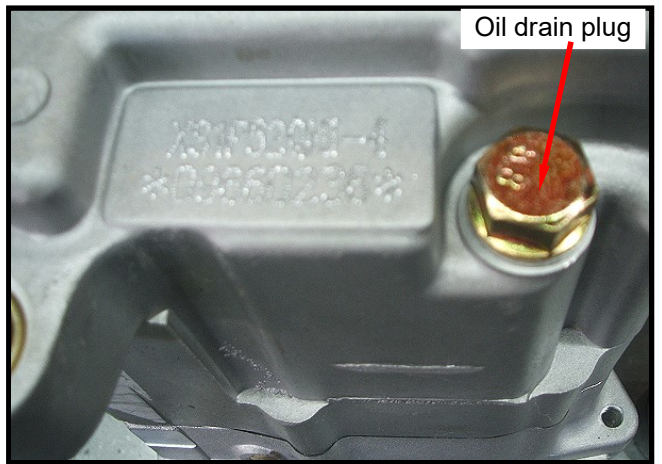

Oil drain plug

CLEANING ENGINE OIL STRAINER

Remove the oil strainer cap.

Remove oil strainer and spring.

Clean oil strainer (recommended using compressed air to clean dirty foreign).

Check if the strainer and O-ring of the oil strainer are broken. Replace with new one if found.

Install the oil strainer and spring.

Install the oil strainer cap and tighten it.

Torque value: 1.0~2.0 kgf-m

Fill out oil to the oil filler (Oil viscosity SAE 10W-30).

Engine oil quantity: Replacement 700 c.c.

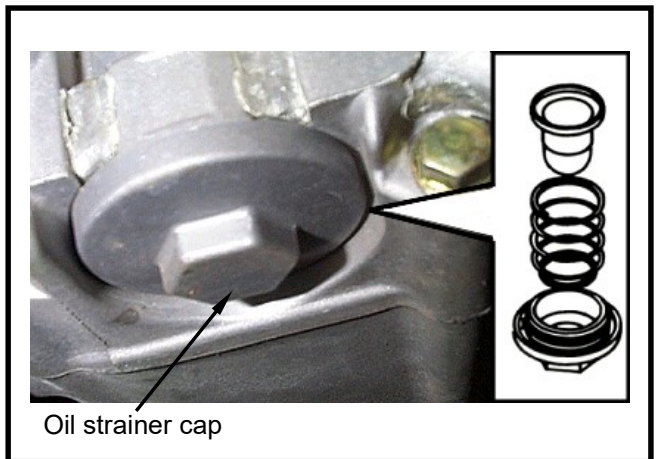

Oil strainer cap

OIL PUMP

Oil Pump Removal

Remove the alternator (refer to chapter10).
Remove the engine right crankcase cover.
Remove the one-way clutch and starting drive gear (1 nut).

Make sure that the pump axle can be rotated freely.

Remove the oil pump cover (2 bolts),
Remove the oil pump fixing flat screw .
Remove oil pump body bolts (2 bolts).

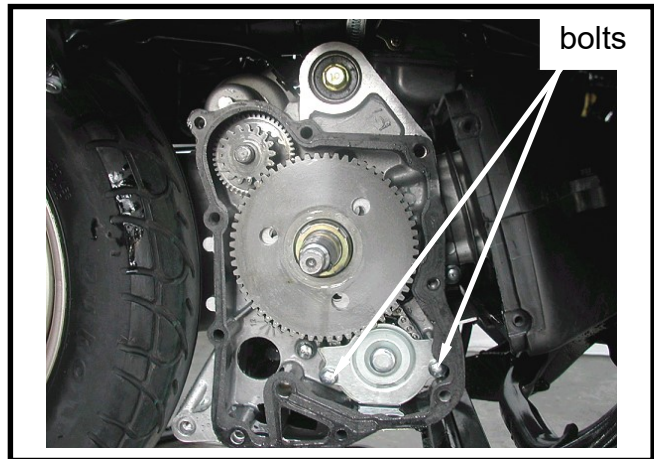

Oil Pump Disassembly

Remove the screw on oil pump cover.
Disassemble the oil pump as illustration shown.

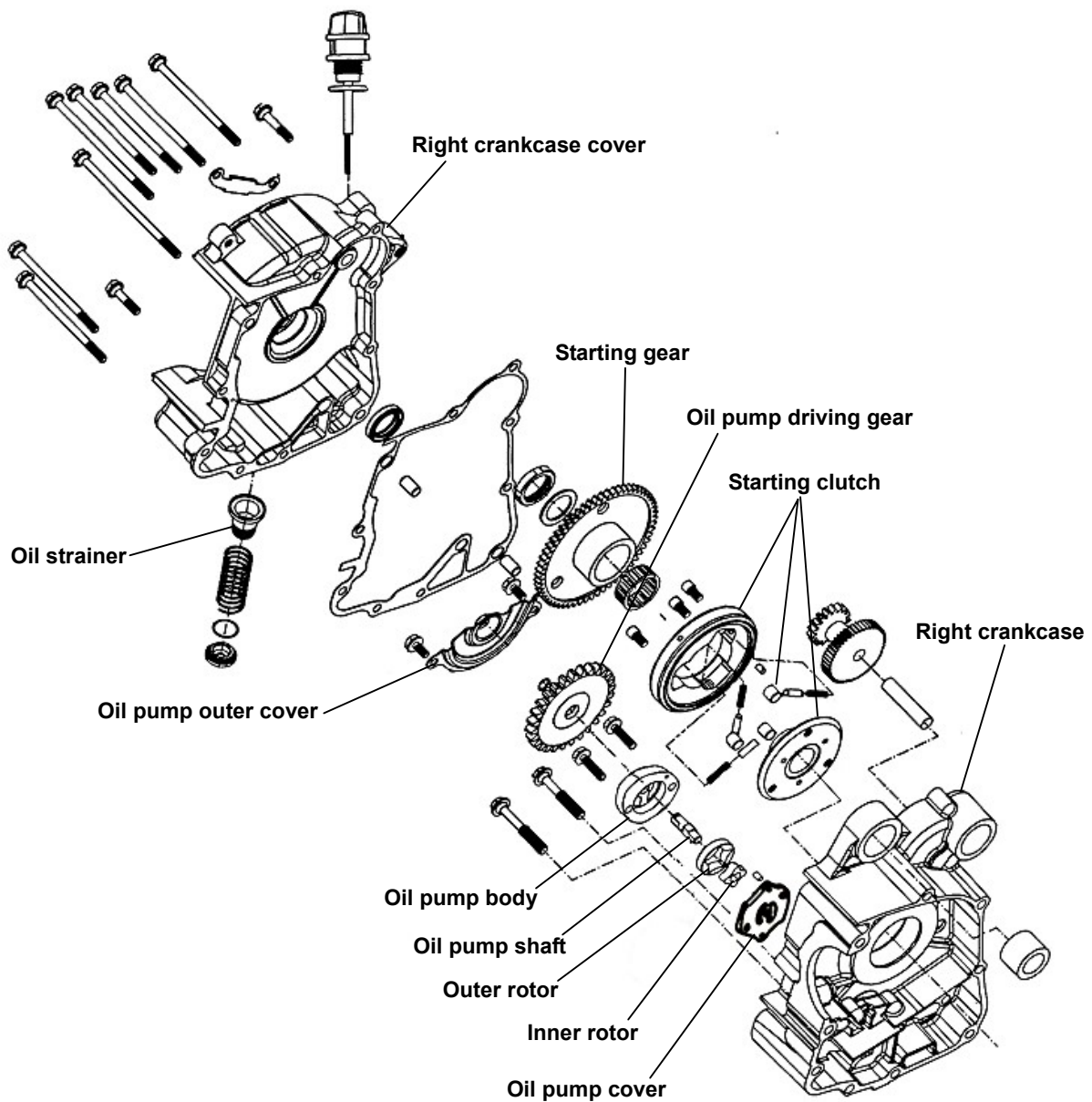

Oil Pump Inspection

Check the clearance between oil pump body and outer rotor.

Limit: below 0.12 mm



Check clearance between inner and outer rotors.

Limit: below 0.12 mm



Check clearance between rotor side face and pump body.

Limit: below 2.0 mm



Oil Pump Re-assembly

Install inner and outer rotors into the pump body.

Align the indent on driving shaft with that of inner rotor. Install the driving shaft.

Install the oil pump cover and fixing pin properly and then tighten screw. (1 screw)



Oil Pump Installation

Install the oil pump (2 bolts).

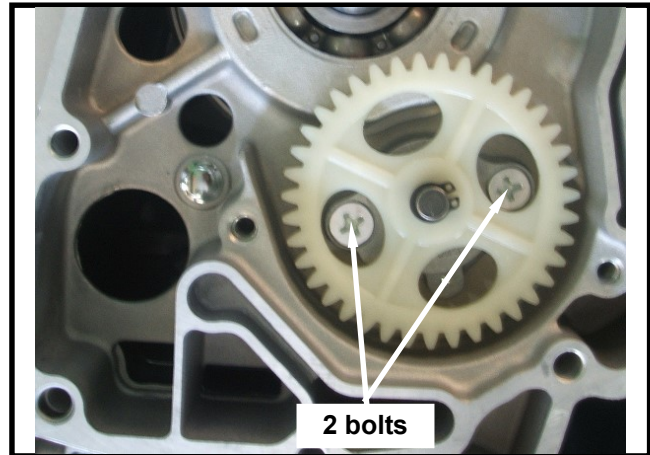

Install oil pump outer cover (2 bolts).

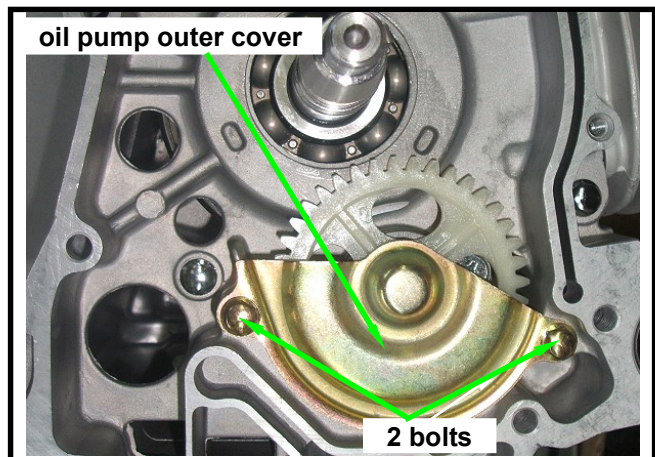

Install the starting gear and the alternator.
(Refer to chapter 10)

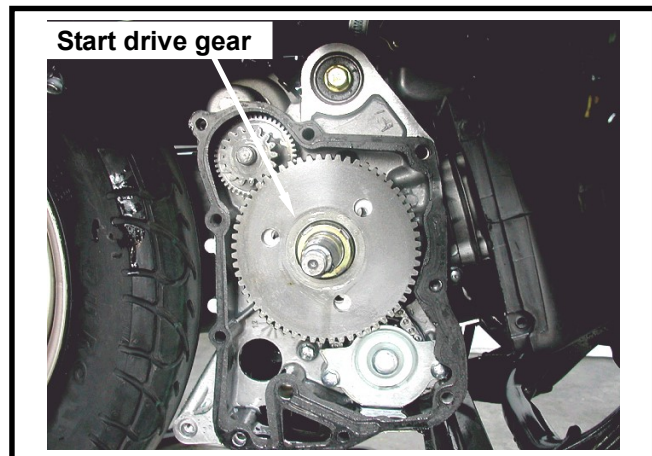

GEAR OIL

Oil Level Inspection

Park the motorcycle on flat ground with main stand.

Turn off engine and remove both engine oil filling bolt and oil draining bolt.

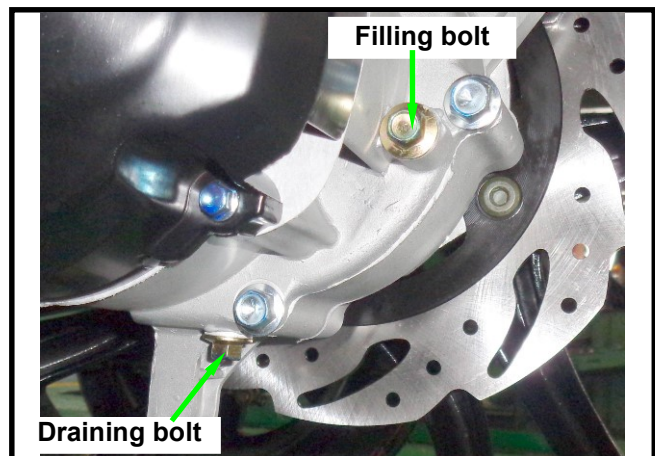

Remove gear oil filling hole bolt and place a measurement cup under the draining plug. Remove the oil draining plug and the pour gear oil into the measurement cup. Measure the gear oil quantity if within standard value. Add specified gear oil if the oil level too low. Standard quantity: 180cc. Replacement:170 cc.

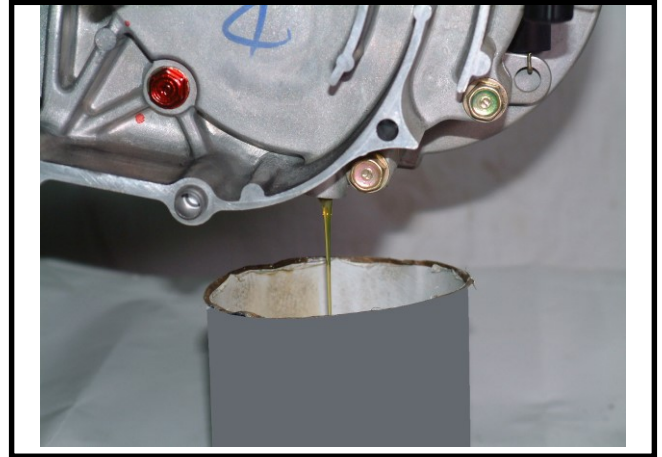

Gear Oil Replacement

Remove the gear oil filling hole bolt and its draining plug and then drain oil completely. Install the draining plug and tighten it. (Make sure if the plug washer is damaged. If so, replace it with new one.)

Torque Value : 1.0~1.5 kgf-m

Add new gear oil (170 c.c.) from the gear oil filling hole and then install the gear oil filling hole bolt after added oil. And then, tighten the bolt.

Torque Value: 1.0~1.5 kgf-m

**※Recommended to apply with SYM
HYPOID GEAR OIL (SAE 85W-140)**

Start engine and run it for 2~3 minutes. Turn off engine and check if oil leaking.

EFi System Diagram	4-1	Crankshaft Position Sensor	4-17
EFi System Introduction	4-2	Engine Temperature Sensor / T-Map Sensor	4-18
EFi System Components	4-3	Air By-pass Valve	4-19
EFi System Location	4-4	Fuel Injector	4-19
EFi System Component Description ..	4-5	Fuel Pump	4-19
EFi System Circuit	4-8	Fuel Unit	4-20
Precautions in Operation	4-9	Fuel Tank	4-23
Troubleshooting	4-10	Air Cleaner	4-24
Throttle Body & By-pass Valve Clean Procedure	4-14	EFi Troubleshooting & Solution	4-25
Fuel Lines	4-15	EFi Components Malfunction Check & Replacement Procedure	4-53
Ignition System	4-16		

EFi System Diagram

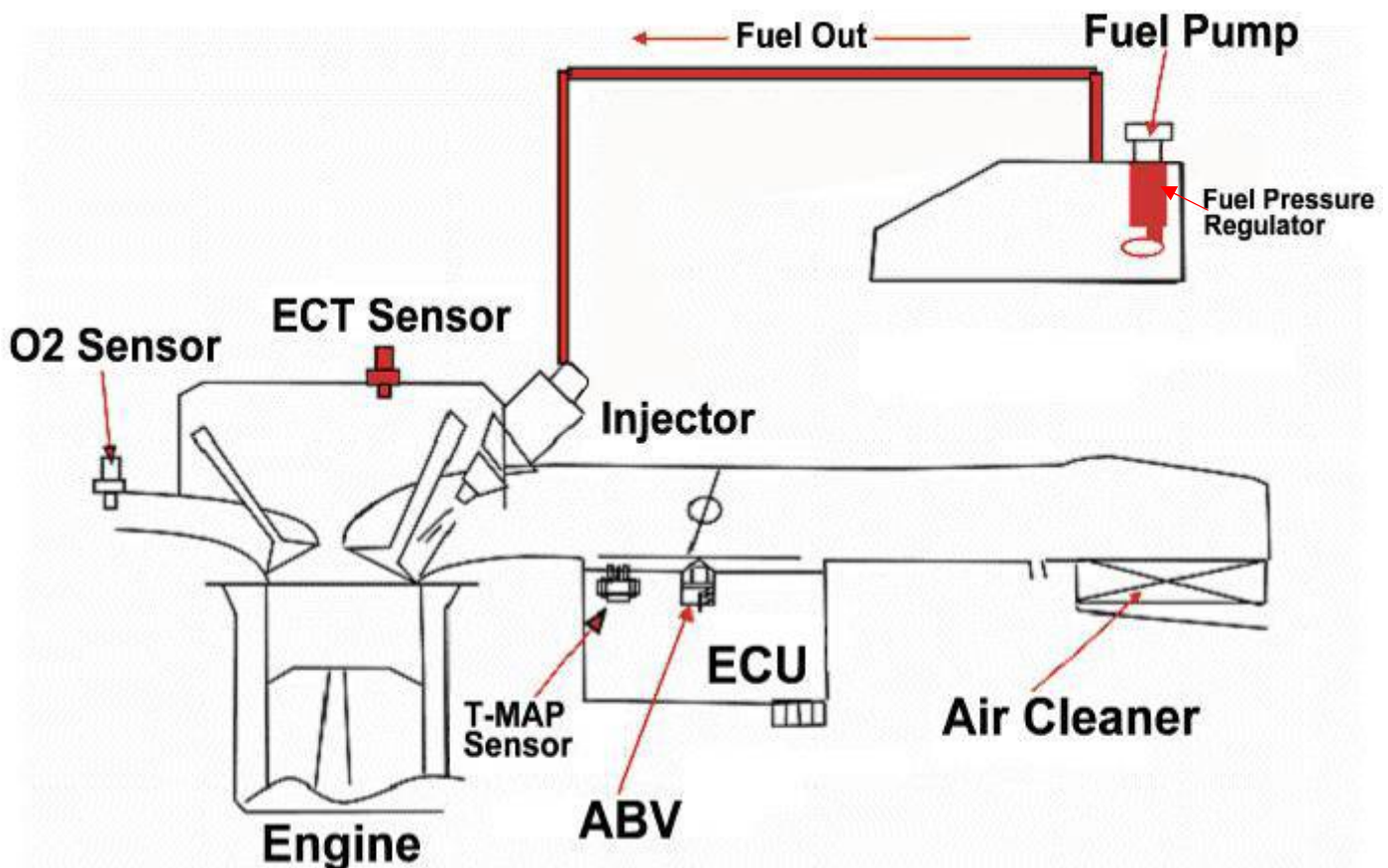

EFi System Introduction

Based on 4-stroke SOHC engine, electronically controlled fuel injection. The O₂ sensor enhances the efficiency of the catalytic converter, by dynamically controlling the Fuel/Air ratio.

Electronic Fuel Injection Device

Fuel supply devices: fuel tank, fuel pump, fuel filter, and fuel pressure regulator.

Fuel control devices: fuel injector, and ECU.

The fuel is pumped from electrical fuel pump in the fuel tank, to the injector on the inlet pipe. The fuel pressure regulator keeps the pressure around 2.5 Bar. The signals from ECU enable the injector to spray fuel into the combustion chamber once each two crankshaft-revolutions. The excessive fuel flows back to the fuel tank through the fuel pressure regulator. Fuel pump is placed inside the fuel tank to reduce the working noise, and the complicity of fuel pipes. Electrically controlled ignition and injection system effectively reduce fuel consumption rate and pollution.

In traditional gasoline engine, carburetor supplies the fuel. The process is done by the engine vacuum, and the negative pressure in the carburetor mixes fuel with air. Under this condition, three major processes are done simultaneously in the carburetor: 1. air quantity measurement, the determination of fuel quantity, the mix of fuel and air.

Electronic fuel injection system separates the three major processes into three different devices:

1. T-MAP sensor measures the air quantity and temperature and sends the signal to ECU as a reference.
2. ECU determines the amount of fuel to be injected, according to the default A/F rate.
3. ECU enables the injector to spray appropriate fuel amount. The independence of these three functions will raise the accuracy of the whole process.

EFi engine uses computer-programmed fuel injection, the main features are:

1. The quantity of fuel injected is determined according to the condition of the engine. The engine RPM, and throttle position determines the fuel quantity and injection time-length.
2. The quantity of fuel injection, and the determination of injection time length, are all controlled by 16-bit microcomputer.
3. The fuel pressure regulator maintains a 2.5 Bar pressure difference between inlet pipe and fuel pipe, raising the accuracy of fuel injection.
4. By measuring the air pressure of inlet pipe, this system gives the vehicle better accommodation to the environment.
5. Air by-pass system supplies fuel and air to stabilize the idle running, and cold starting.

EFi System Components

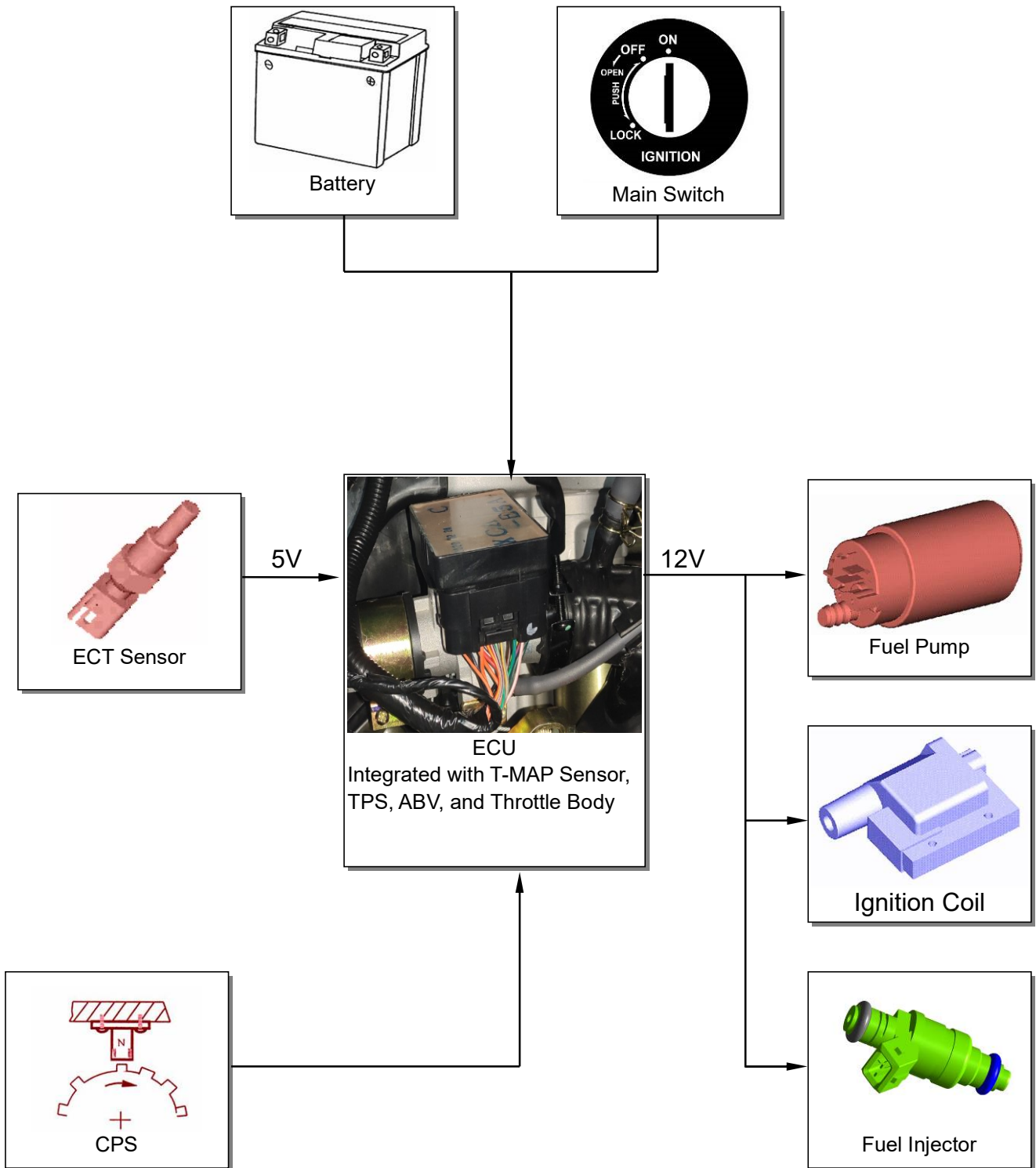

Efi System Location

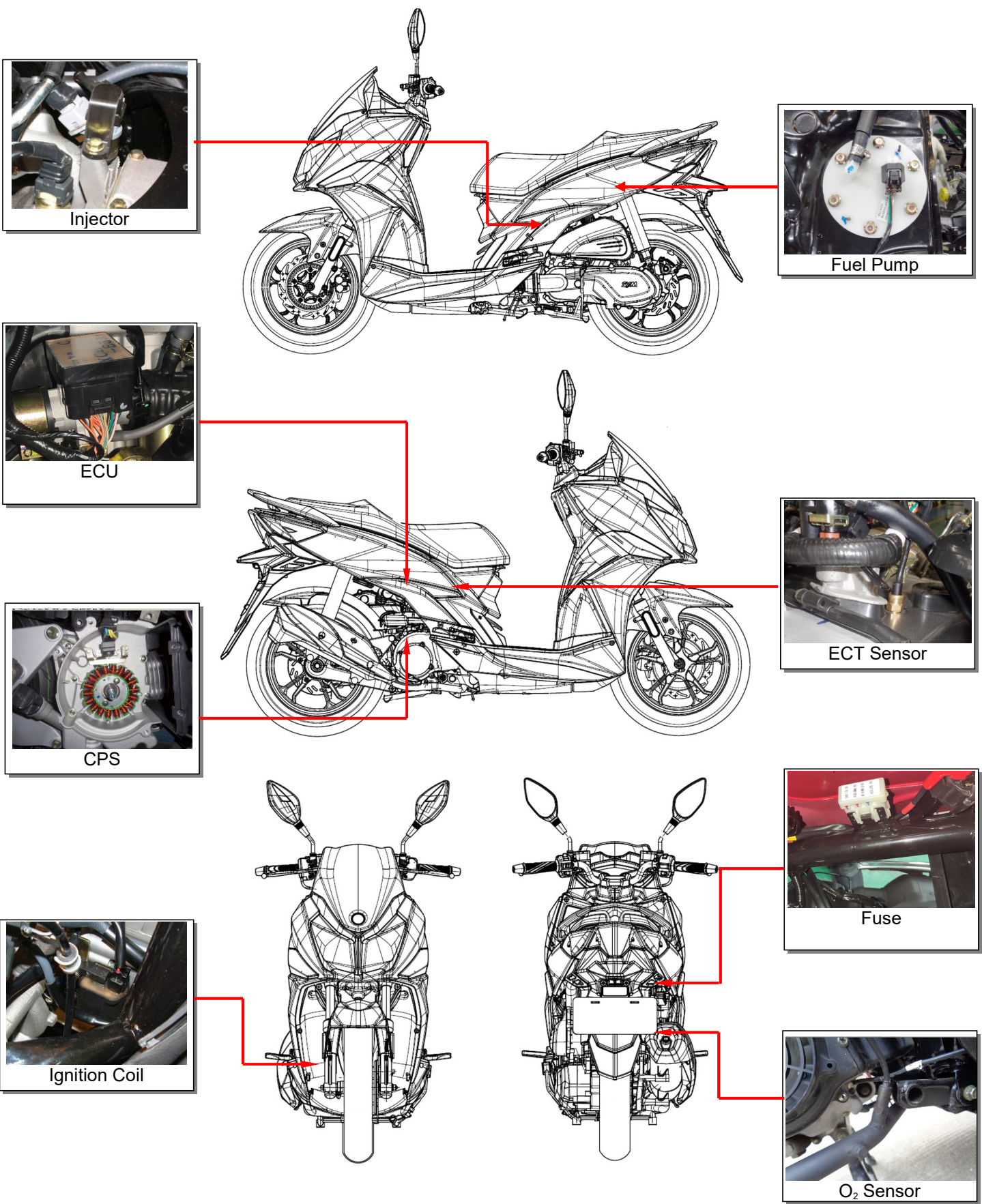

EFi System Component Description

Integrated ECU Module

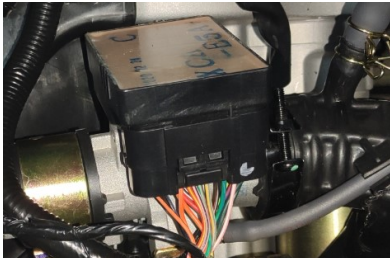

Engine Control Unit (ECU)

- Powered by DC 8~16V, and has 32 terminals connector on the unit.
- The hardware component consists of an 16-bit computer that is its control center. It contains the functional circuit interface of engine condition sensing and the driving actuator for the air by-pass valve, fuel injector, and fuel pump, as well as transistor ignition coil.
- Its major software is a monitor strategy operation program that includes with controlling strategy, microarray profile and self-diagnosis programs.

Air Bypass Valve (ABV)

- Its major component is the solenoid valve of high resistance driven by electric current.
- By means of signals from all sensors, ECU outputs a signal to control the opening angle of the valve so that can adjust air flowing to the inlet manifold through the air by-pass valve, and then correct the idle speed to have engine in normal operation.

T-MAP Sensor

- The major component of the T-MAP sensor is a variable transistor IC. Its reference voltage is DC 5V, and output voltage range is DC 0~5V.
- It is a sensor of combination by both sensing pressure and temperature, and can measure the absolute pressure and temperature in intake process. It also conducts the fuel injection quantity correction based on environmental temperature and position level.

Throttle Position Sensor (TPS)

- Its major component is a highly variable resistor. The input voltage range: 5V DC.
- Located on the side of throttle body. By means of the throttle valve rotation to cause voltage change in linear, it provides ECU with current throttle valve openness information. And also, the ECU determines the most properly fuel injection and ignition timing.

Fuel Injector



- Powered by DC 8~16V, and has 2 terminals connector on the injector.
- Its major component is the solenoid valve of high resistance driven by electronic current.
- The two terminals are connected to power source and ground respective. It is controlled by ECU to determine the injection timing, and the injector pulse width. Working with 2-valve engine, the unique 2-hole designed injector can provide each intake valve with suitable fuel quantity to reduce HC emission.

Fuel Pump

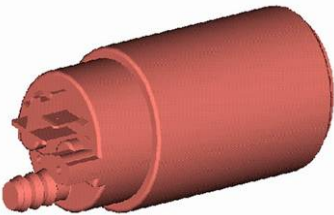

- Powered by DC 8~16V, and has 2 terminals connector on the pump.
- The two terminals are connected to power source and ground respective. The ECU is to control and manage the operation of fuel pump through electrical power.
- Its major component is a driving fan pump that equipped with a low electrical consuming DC motor. Powered by 12V voltage and keep fuel pressure inside the fuel pump in 2.5 bars, which can offer 14 liters of fuel per hour.
- The fuel pump is located inside of the fuel tank, and installed a filter in front of its inlet so that can prevent from foreign materials sucking into the fuel pump to damage it and the fuel injector.

Ignition Coil

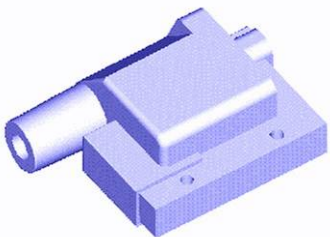

- Powered by DC 8~16V, and has 2 terminals connector on the coil.
- The two terminals are connected to power source and ground respective. Its major component is the high transferring rate transformer.
- Its ignition timing is controlled by computer program. From the signals of crankshaft position sensor, throttle position sensor, and engine temperature sensor as well as intake air temperature sensor, and correspondence with engine speed, then the ECU determines the ignition timing properly by means of controlling primary current in ON & OFF operation to create the secondary voltage of 25000~30000V. And then, the voltage triggers the spark plug ignition. Such kind of ignition system not only can enhance engine performance to maximum, but also increases fuel consumption efficiency and improves emission quality.

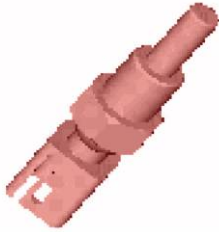
ECT Sensor

- Powered by 5V DC from ECU, and has 2 terminals connector on the sensor. One terminal is for voltage output and the other one for ground.
- Its major component is the thermo-resistance of negative temperature coefficient (temperature rises up while resistance falls down).
- Located on the cylinder head. Correspondence with engine coolant temperature change, it transferred to voltage signal and sent to ECU to calculate current temperature. Then, the ECU will correct fuel injection time and ignition timing according to engine warm up condition.

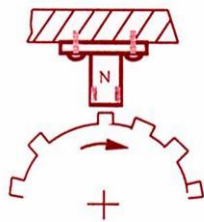
CPS

- It does not need power supply, and has 2-signal terminals connector on the sensor.
- Its major component is the magnetic pickup coil, and its output voltage range is $\pm 0.8\sim 100V$.
- The air gap between the sensor and flywheel must have 0.7~0.9mm.
- By cutting the magnetic field, the magnetic sensor sends an inductive voltage that is created with the rotation gear (24-1 tooth) on the flywheel, and the pulse will be sent to the ECU. Then, the ECU calculates current engine speed and crank position based on the voltage so that controls fuel injection quantity and ignition timing properly.

O2 Sensor

- Powered by DC 8~16V, and has 1 terminals connector on the sensor. the one is for signal output.
- The O2 sensor feeds signal to ECU, and the ECU can control the air/fuel rate around 14.6. It's a close-loop control system.
- The catalytic converter reaches the best converting rate when this 14.6 A/F ratio is maintained.
- The heating coil resistance <math>< 200\text{kohm}</math> (30—45kohm)

Precautions in Operation

General information

Warning

- Gasoline is a low ignition point and explosive materials, so always work in a well-ventilated place and strictly prohibit flame when working with gasoline.
- Release the fuel pressure before removing the fuel pipe to prevent splashing the fuel.

Caution

- Do not bend or twist throttle cable. Damaged cable will make unstable drive ability.
- When disassembling the fuel system parts, pay attention to O-ring position, replace with new one as re-assembly.

Fuel pressure release procedure:

Disconnect the fuel pump relay, switch on and press the start switch for a few seconds to crank the engine.

Specification

Item	
Idle speed	1800 rpm
Throttle grip free play	2~6 mm
Fuel pressure	2.5 bar

Torque value

Engine temperature sensor : 0.74~0.88 kgf-m

O2 sensor : 3.6~4.6 kgf-m

Troubleshooting

EFI circuit inspection

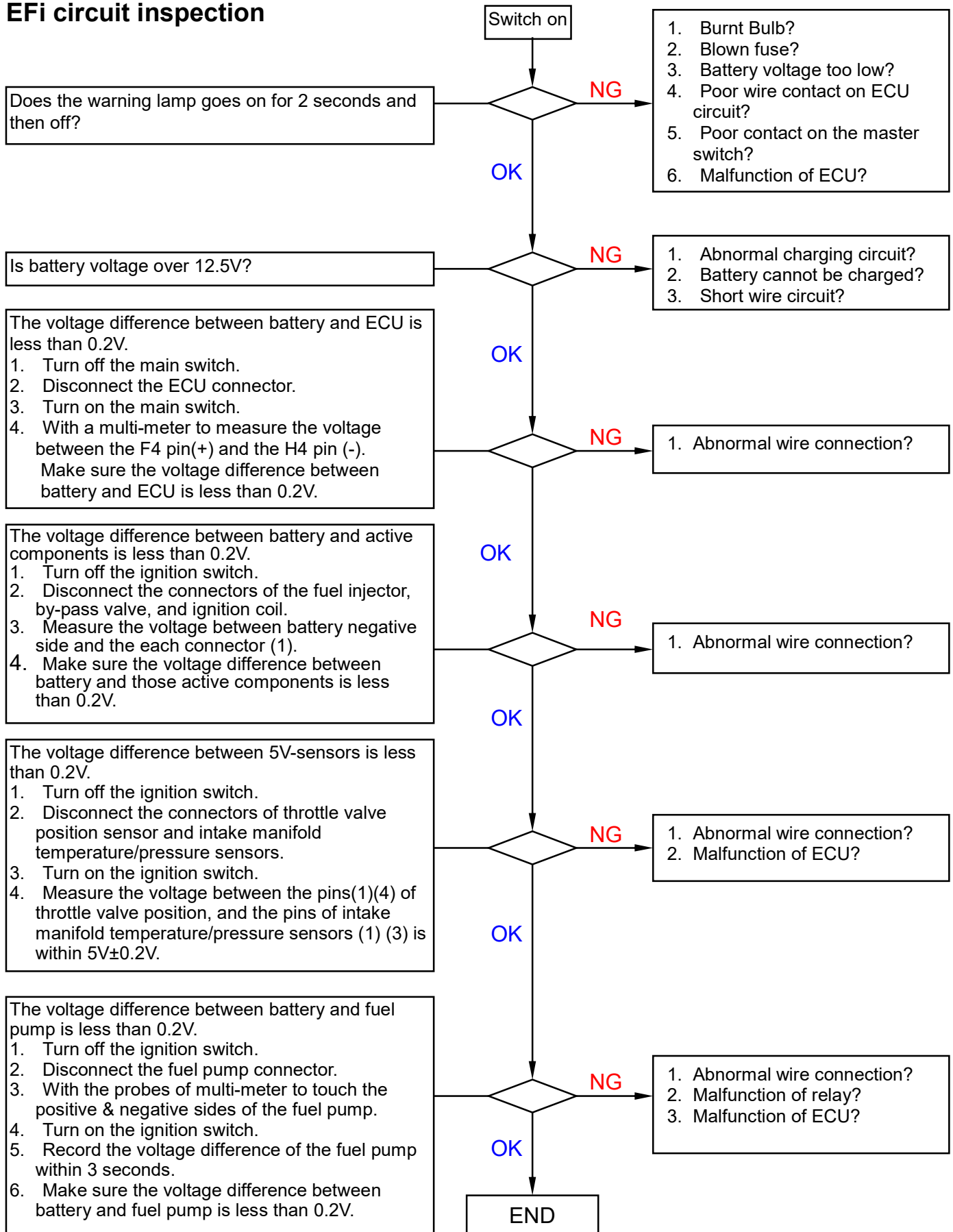

Engine cannot be started or difficult to start.

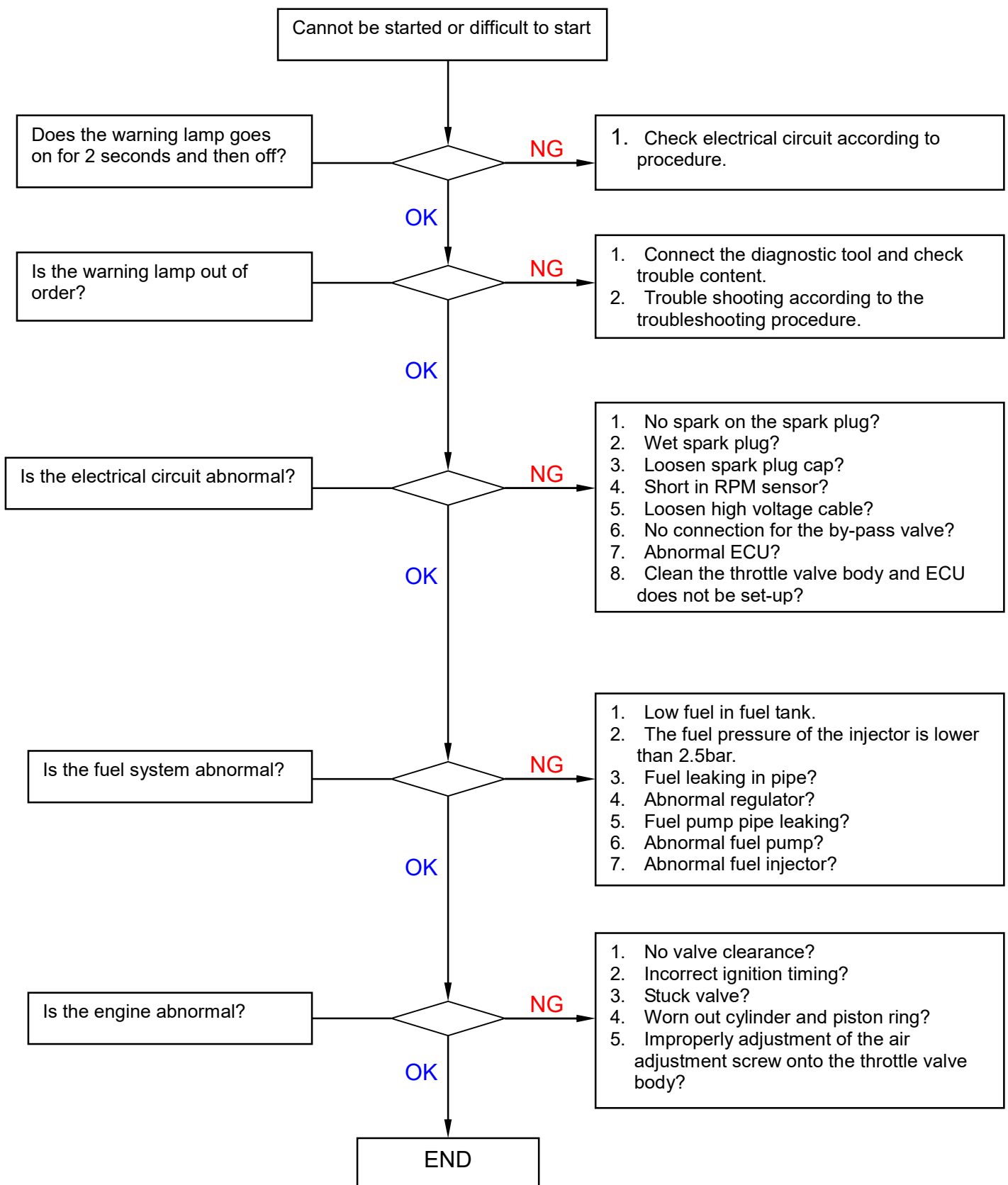

Diagnosis of Idle Speed Misfire

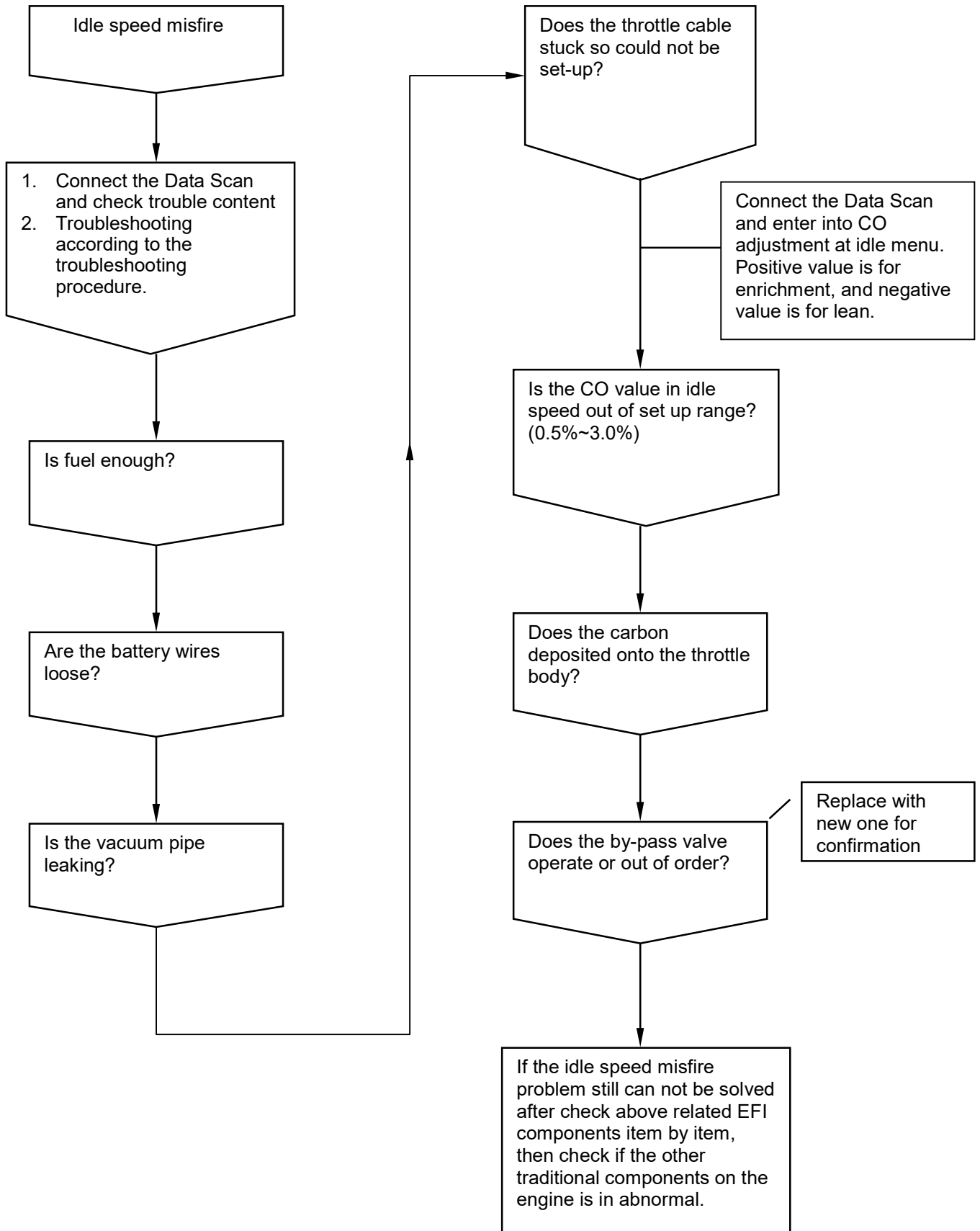

Abnormal CO value

If the system has O2 sensor, the CO value doesn't have to be adjusted. If the CO value still goes abnormal, please check O2 sensor first, to see if any malfunction occurred.

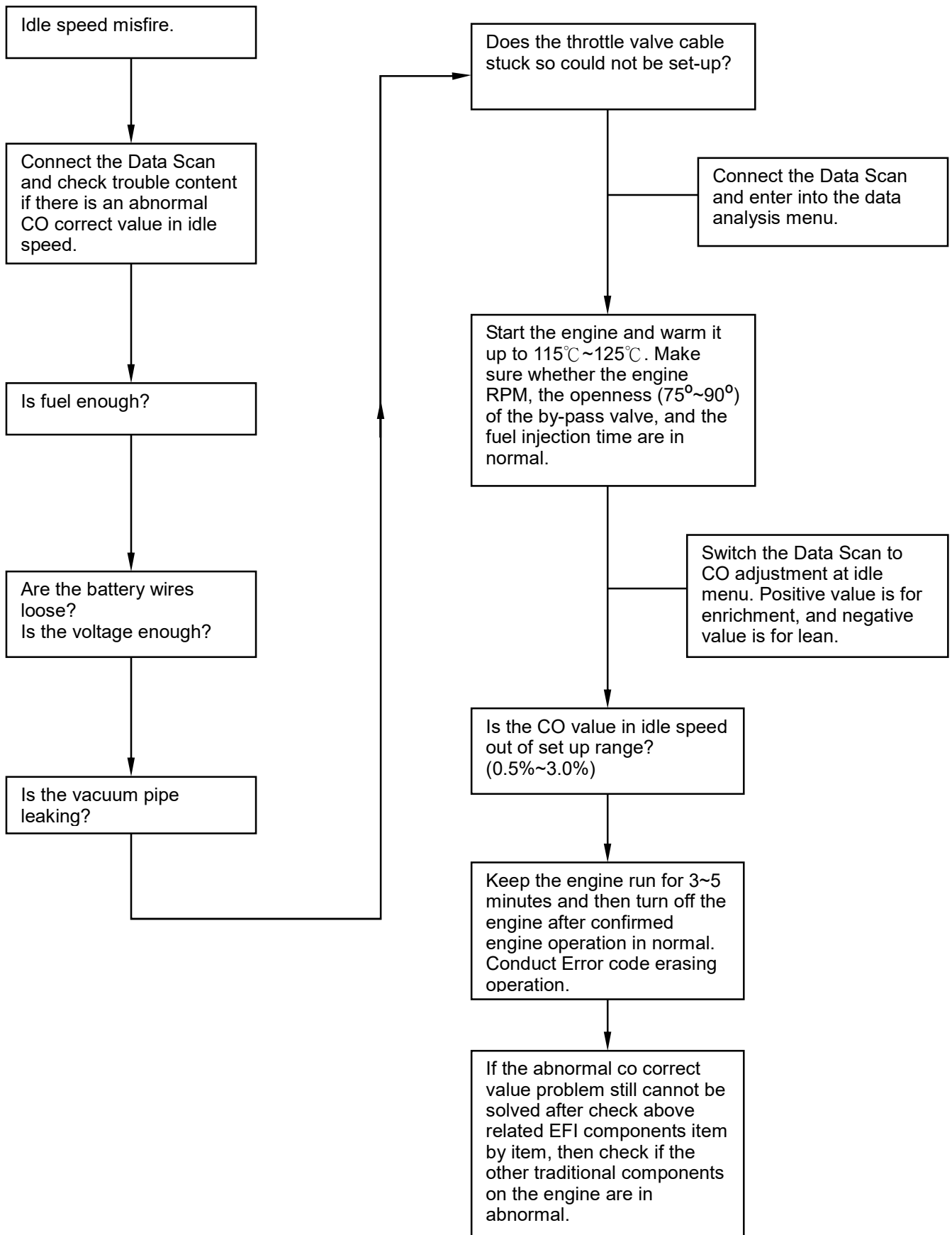

Throttle Body & By-pass Valve Clean Procedure



- It's suggested that clean the air by-pass valve before cleaning the throttle body.
- Recommended cleaning frequency: every 6000 km.

Clean procedure:

1. Air by-pass valve :

1. Switch off; disconnect the air tube between the air by-pass valve and connecting pipe.
2. Turn on the engine and keep the idle speed.
3. Spray a little carburetor cleaner into the air by-pass valve for 3~5 minutes. Do not shut down the engine during cleaning.
4. Connect the air tube.

2. Throttle body:

1. Switch off; remove the throttle body.
2. Spray a little carburetor cleaner into the throttle body.
3. Wipe off the dirty oil with clean cloth or tissue.
4. Dry the throttle body with compressed air and install the throttle body. Connect the diagnostic tool and switch on.

Idle speed learning:

After performing air by-pass valve or throttle body cleaning, idle speed learning should be carried out to let ECU know the engine condition well.

When performing the idle speed learning, run the engine at idle speed over 10 minutes after the engine temperature reaches the working temperature (around 70°C~95°C), and then ECU will get the parameters from sensors.

Fuel Lines

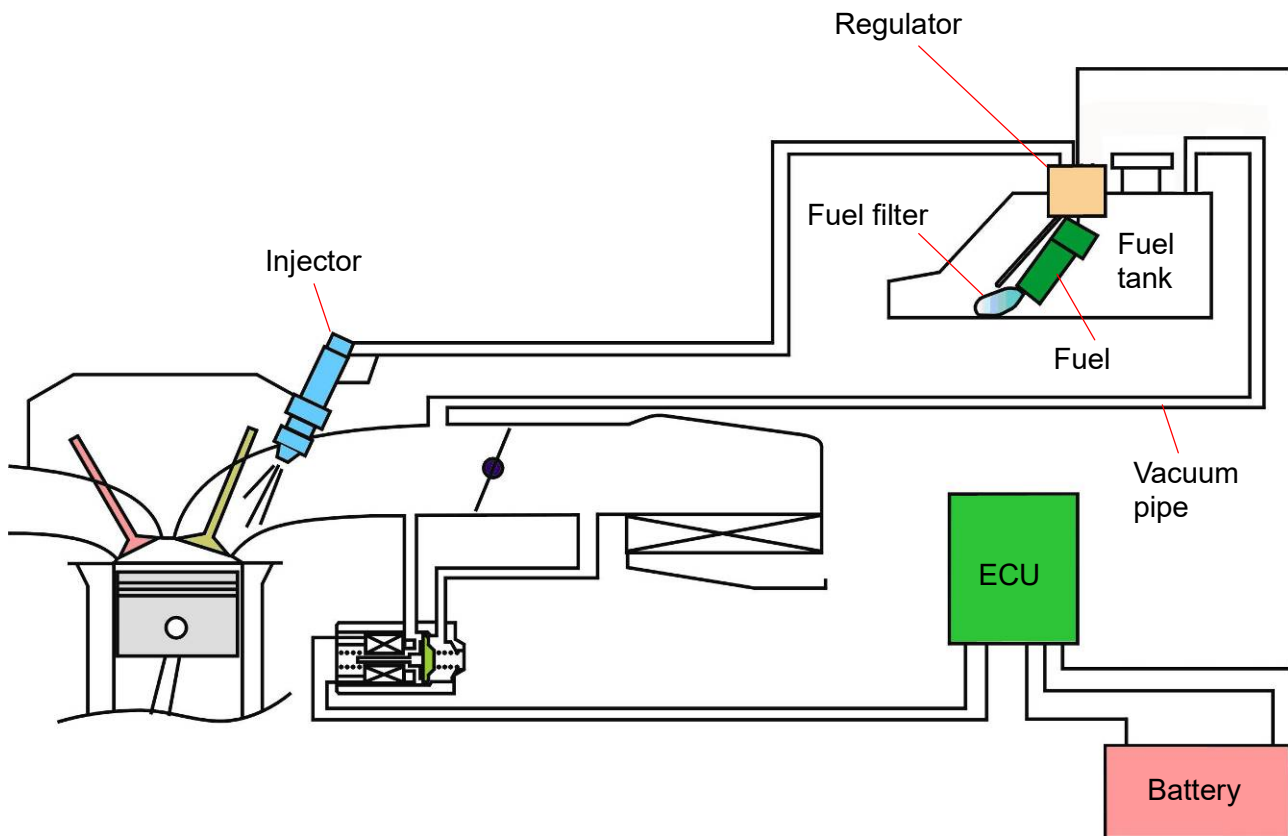
**System description:**

1. After key-on, all sensors' signals sent to the ECU first. The electrical fuel pump will be activated by ECU signal. If the engine did not start for 2~3 seconds, then the fuel pump will be turned off to save electricity. The pressure regulator maintains the fuel pressure around 2.5 Bar, and the fuel injector spray proper fuel quantity according to the conditions and environmental coefficient. When key-off or engine stopped, the fuel pumps stop operating.
2. The fuel filter is to filter alien materials so it has to be replaced regularly.
3. Do not let the starting motor keep running when the engine cannot start. It will cause battery voltage to decrease. If the voltage drops under 8V, the pump will not operate. The countermeasure will be starting the engine by connecting a new battery or with kick-starter.

Ignition System

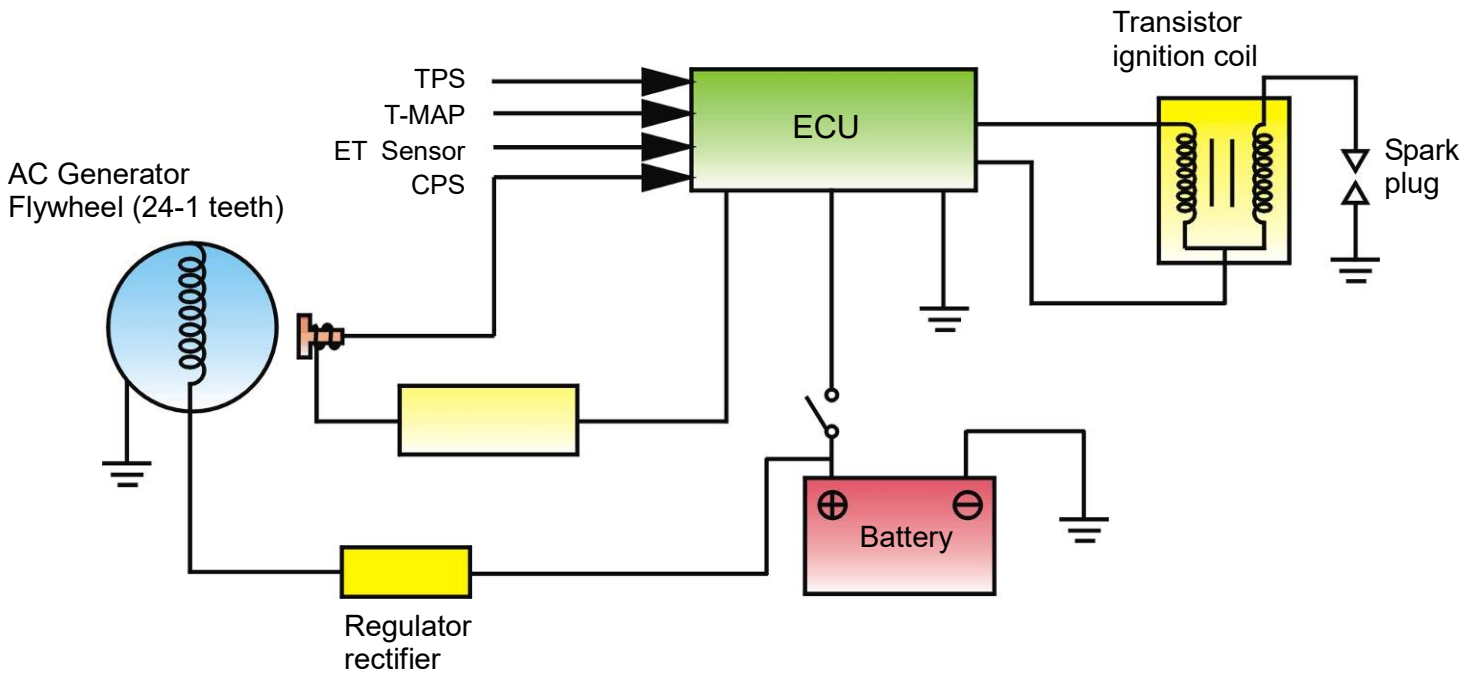

Principle of operation

The engine is equipped with a computerized ignition control system that collects signals from CPS, TPS, ET Sensor, and T-MAP Sensor. Then, correspondence with engine RPM, this 8-bit microcomputer in the system controls ignition timing properly. The secondary coil creates 25000~30000V high voltage to ignite the spark plug by means of the transistor operation of the primary current entry from the ECU. This can maximize engine performance and also decrease fuel consumption.

Specification

1. Ignition timing: **BTDC 10° / 1700RPM**
2. Spark plug: **CR7HSA**
Gap: **0.8mm**
3. CPS pulse generator coil: **80~160Ω / 20°C (G/W-LY)**
4. Ignition coil
Primary circuit : **0.63±0.03Ω (23°C)**
5. Battery Capacity: **12 V 6Ah**

Crankshaft Position Sensor

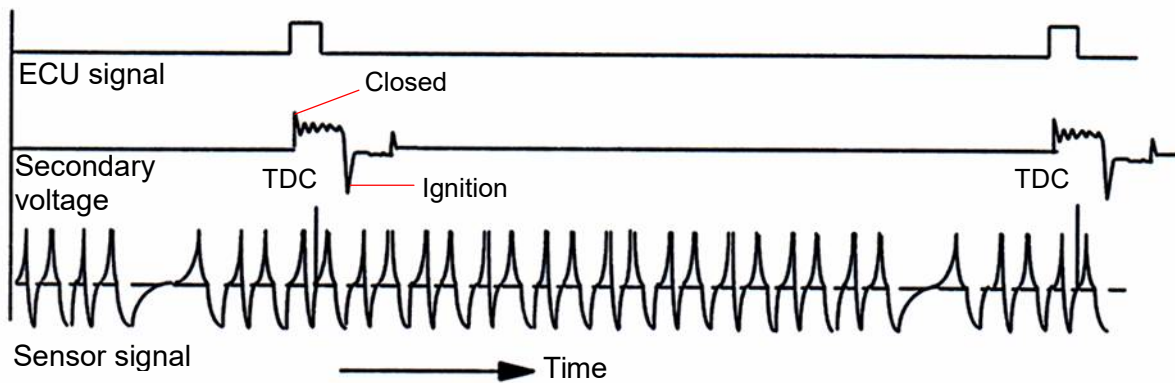
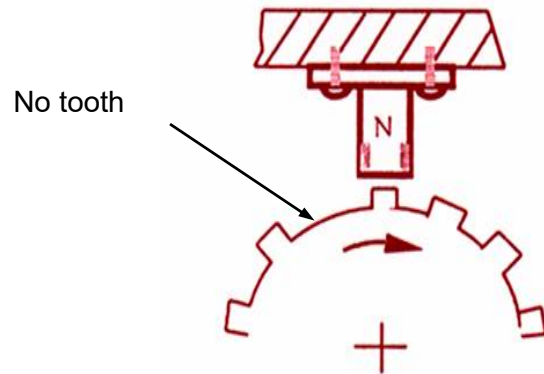

Description:

The magnetic field type sensor generates a voltage signal to calculate engine speed with ACG gear ring (24-1 tooth).

There is one tooth every 15 degree on the gear ring. But, one of the teeth is blank for the TDC calculating base.

Engine Temperature Sensor / T-Map Sensor

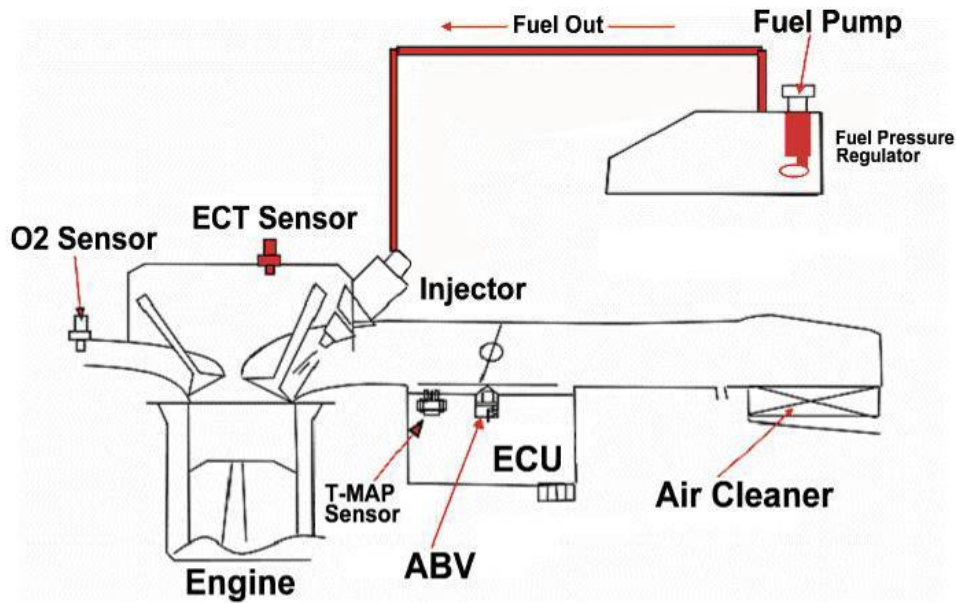

Engine temperature sensor:

According to the semiconductor's characteristic, the sensor detects the temperature of engine oil and metal parts and then sends a voltage signal to the ECU. On this base, the ECU can correct fuel injection and ignition timing.

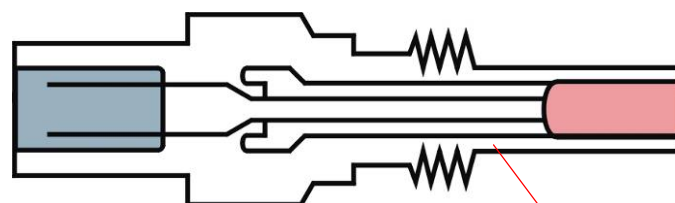

NTC- Negative Temperature Coefficient Resistor

T-MAP Sensor :

Sensor combined both pressure and NTC can detect the absolute pressure and temperature in the intake manifold, and then provides the ECU with signal for adjustment fuel injection quantity based on environmental temperature and air pressure difference from elevation level change.

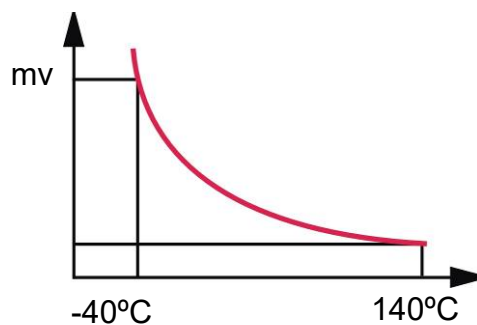

Air By-pass Valve

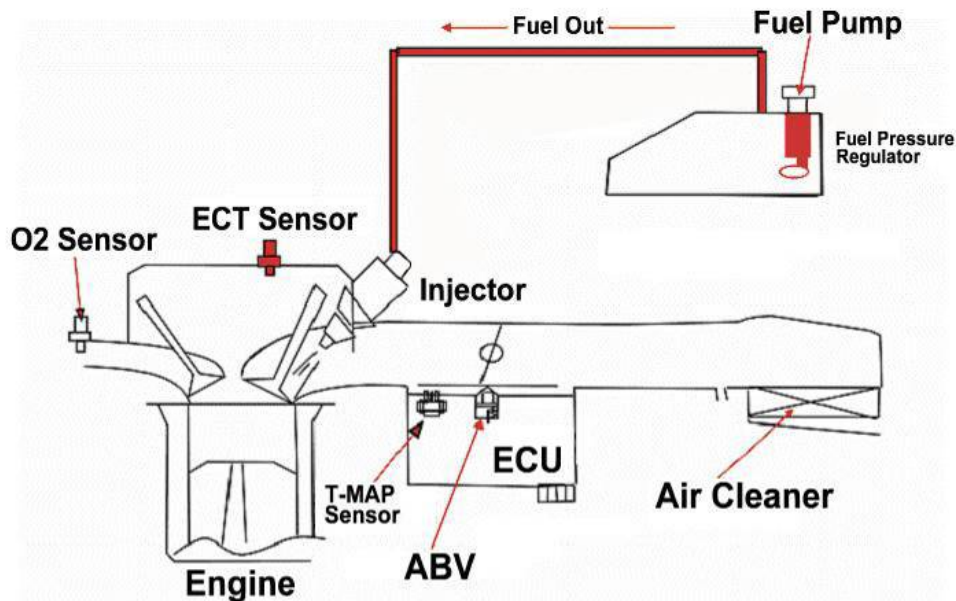

Description:

ECU receives all sensors' signals to control the throttle valve openness with PWM, and adjust airflow through the by-pass valve of the intake manifold. It can adjust idle speed for a stably running engine.

1. When engine cold starting---the by-pass valve open for a while to increase airflow and to stabilize engine idle speed within initial starting
2. Warm-up---when engine oil is in low temperature condition, the by-pass valve adjusts airflow according to engine temperature (engine oil temperature), and raises idle speed.
3. Speed decreasing--- ECU controls the by-pass valve in correspondence with throttle operation, to provide inlet pipe with proper airflow quantity. Such operation will smooth the engine rpm reduction process, preventing the engine from stalling, excessive negative pressure, and also reduce HC emission.

Fuel Injector

The injector provides intake valve a fuel jet. This can reduce the pollution of HC. The shortened version of fuel pump plate makes its size more compact, and sturdier against shocks. ECU signal controls the regulator to maintain 2.5 bars between the fuel pressure and the air pressure of inlet pipe. Through controlling the time length of injection under steady fuel pressure, the system can optimize the fuel injection quantity according to different engine workloads.

Fuel Pump

Electrical fuel pump is mounted inside the fuel tank. The power source is DC current provided and controlled by ECU; the pump can provide 14L/hour under the pressure of 2.5 bars.

Fuel Pump / Fuel Unit

Removal

Removal

Open the seat.

Remove 5 sockets in the rear carrier & fuel tank cover.

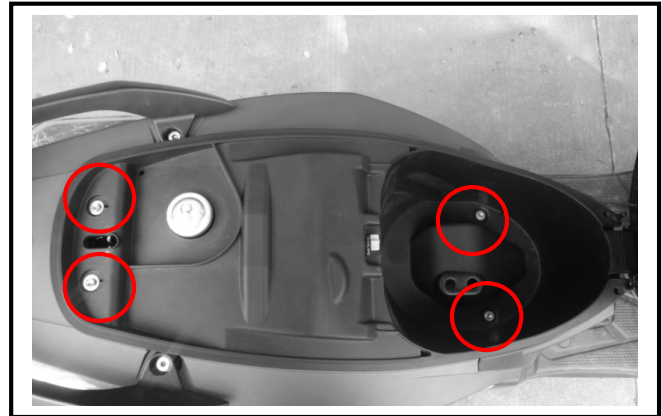

Remove the body cover.

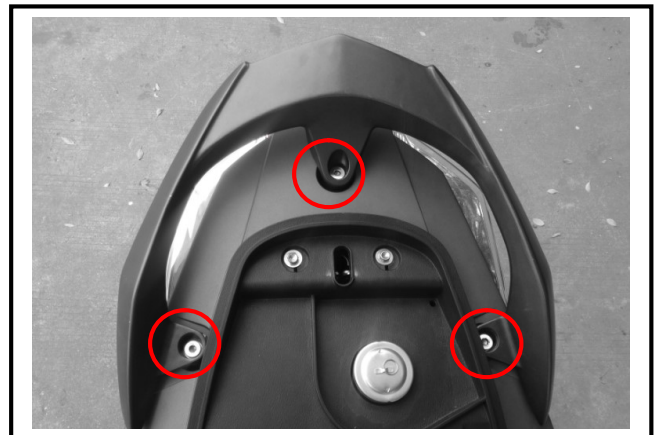

Disconnect the fuel pump couplers.
Disconnect the fuel unit couplers
Remove the fuel pipes.

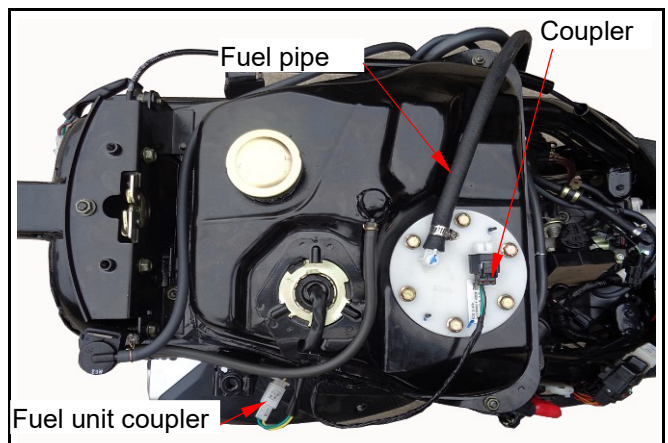

Remove the fuel pump lock bolts.

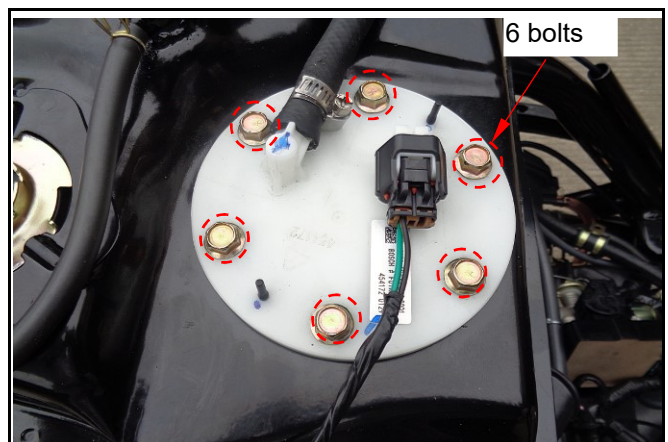

Remove the fuel pump and fuel unit.

⚠ Caution

- Check if the oil seal is deformed or damaged. Replace it with new one if necessary.

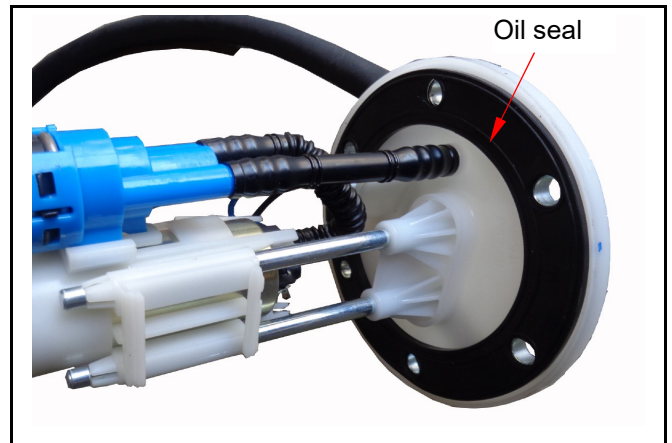

Check if the fuel filter is contaminated or clogged. Replace it with new one if necessary.

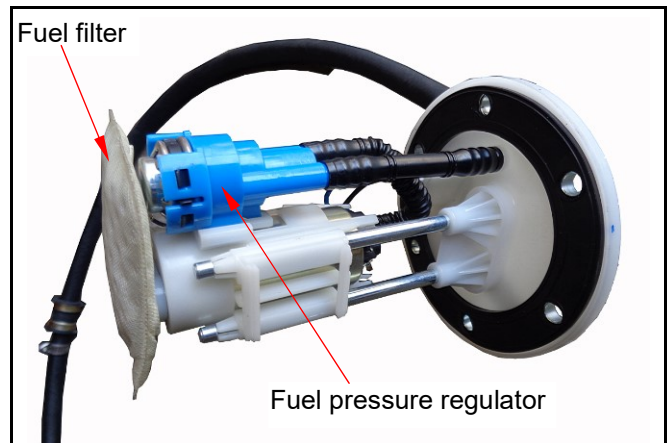

Remove the fuel unit.
Check the oil seal of fuel unit for any damage or deformation.

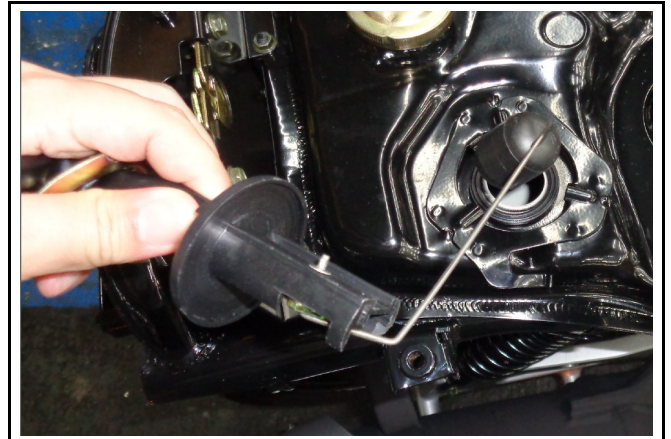

Installation

Install in the reverse order of removal.

⚠ Caution

- Do not bend the fuel unit float arm
- Do not fill out too much fuel in the tank.
- Align the assembly mark when installing the fuel pump and fuel unit.
- Replace the oil seal if any damage or deformation is found.

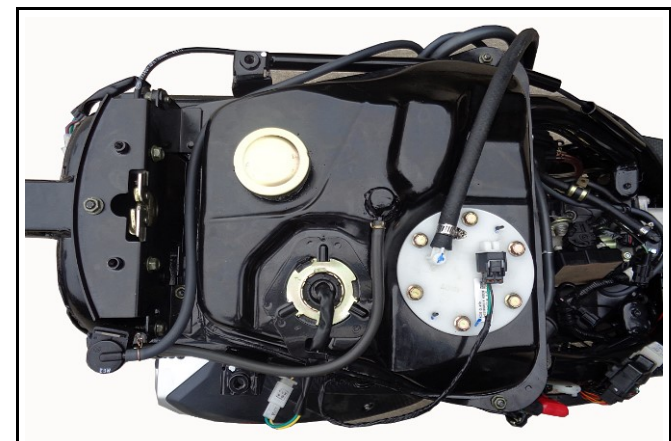

Inspection :

Disconnect the fuel pipe from the fuel injector.
Connect the fuel pressure gauge to check the fuel pressure.

⚠ Caution

- Make sure the fuel pressure is normal (2.5 bar).
- Always release the fuel pressure before removing the fuel pipe to prevent the fuel from splashing.

Special tool :**Fuel pressure gauge SYM-HT07010**

Replace the fuel pump with new one if malfunction is confirmed.

Fuel Tank**Removal**

Disconnect the fuel pump and the fuel unit coupler.

Remove fuel pipe.

Remove the fuel cut valve pipe.

Remove the fuel tank (4 lock bolts).

Installation

Install in the reverse order of removal.

⚠ Caution

- Make sure the fuel in the tank is not too much before removing the fuel tank.
- Replace the fuel tank if there is any damage or leakage.

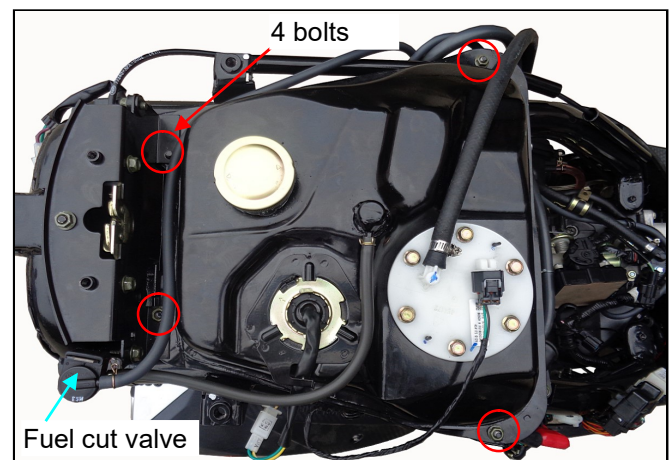
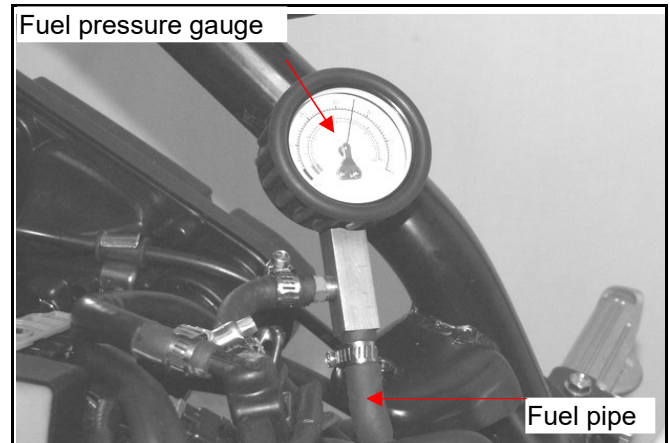

Air Cleaner

Remove the air cleaner cover (9 screws).

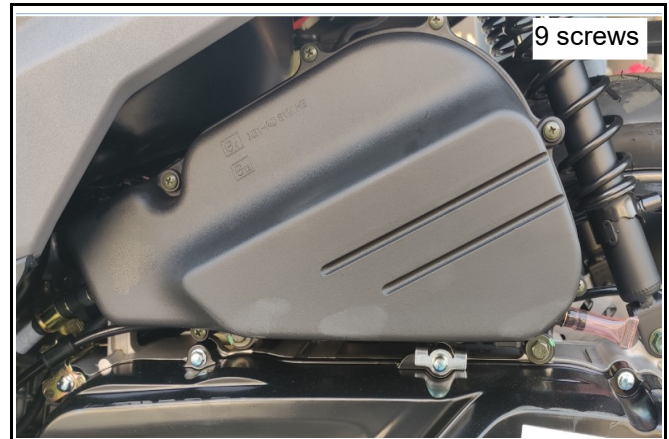

Remove the air cleaner element .



Caution

- The air cleaner is paper-base; please blow it clean with compressed air. Don't use water or other solvent
- Replace it with new one if the dirt cannot be removed.

Installation

Install in the reverse order of removal.

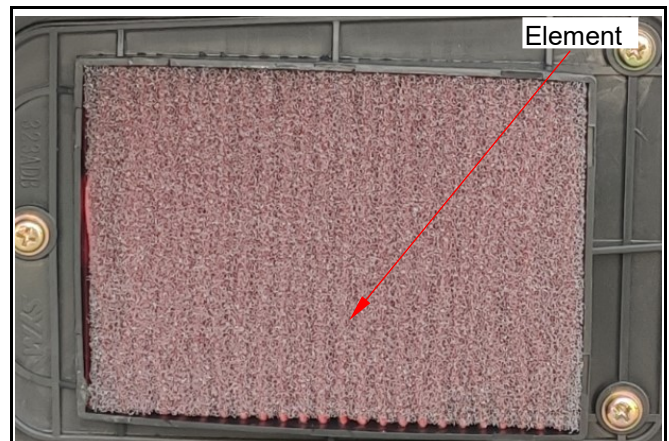

EFi Troubleshooting and Solution**•Electronic fuel injection (EFi) system fault warning light**

After the main switch is on, the EFi indicator will be light. If the vehicle existing problems, the EFi indicator will light up all the time after the electrical starter button is on. When the problem is eliminated, restart the electrical starter button, the EFi indicator will light out automatically.

Error Code Message and Solution Operation

	Component	DTC	DTC Description	Monitoring Strategie
1	Engine Coolant Temperature sensor	P0117	Engine Coolant Temperature Circuit Low Input	Signal shorted to ground
		P0118	Engine Coolant Temperature Circuit High Input	Signal shorted to Battery or circuit open
		P0116	Engine coolant temperature sensor range problem	Tco out of range
		P0116	Engine coolant temperature sensor stuck problem	Stuck Tco Signal
2	Intake Air Temperature sensor	P0112	Intake Air Temperature Circuit Low Input	Signal shorted to ground
		P0113	Intake Air Temperature Circuit High Input	Signal shorted to Battery or circuit open
		P0111	Intake air temperature sensor range problem	TIA out of range
		P0111	Intake air temperature sensor performance problem	Stuck TIA Signal
3	Manifold Absolute Pressure sensor	P0107	Manifold absolute pressure sensor Circuit Low Input	Signal shorted to ground
		P0108	Manifold absolute pressure sensor High Input	Signal shorted to Battery or open
		P0106	Manifold absolute pressure sensor range problem	MAP Signal out of range
		P0106	Manifold absolute pressure sensor stuck problem	Stuck MAP Signal
4	O2 Sensor Signals	P0131	O2 Sensor Signals circuit low Voltage	Signal shorted to ground
		P0132	O2 Sensor Signals circuit High Voltage	Signal shorted to Battery

5. Fuel Injection System

SYM

		P0134	O2 Sensor Signals circuit open	Signal open circuit
		P2A00	O2 Sensor Signals out problem	Signal out of range
		P0133	O2 Sensor Circuit Slow Response	Signal Plausibility
5	Throttle Position Sensor	P0122	Throttle position sensor circuit low or circuit open	Signal shorted to ground/ circuit open
		P0123	Throttle position sensor circuit high	Signal shorted to Battery
6	Fuel Injector	P0261	Fuel Injector circuit low	Signal shorted to battery or open
		P0262	Fuel Injector circuit High	Signal shorted to ground
7	Idle Air Control system	P0508	Step motor circuit lower or circuit open	Signal shorted to ground or open
		P0509	Step motor circuit high	Signal shorted to Battery
		P0519	Step motor circuit Plausibility problem	Signal Plausibility
8	Ignition Coil Control System	P2300	Primary coil low/ no current	Signal shorted to ground or open
		P2301	Primary coil overcurrent	Signal shorted to Battery
9	O2 Sensor Heater System	P0031	O2 sensor heater circuit lower	Signal shorted to ground
		P0032	O2 sensor heater circuit high	Signal shorted to Battery
		P0131	O2 sensor heater circuit open	Signal open circuit
		P0135	O2 Sensor Heater Circuit Malfunction	O2 sensor heater Plausibility
10	CrankShaft Position Sensor	P0335	CrankShaft Position Sensor circuit open	Present crank error
11	Fuel Pump	P0231	Signal shorted to ground or open	Signal shorted to ground or open
		P0232	Step motor circuit high	Signal shorted to Battery

12	Engine Over Temperature	P0217	Engine Overtemp Condition	None
13	Battery	P0562	System voltage low	None
		P0563	System voltage high	None
14	Mis Fire A diagnosis	P0314	Cylinder Misfire Detected	Mis fire detected
15	Mis Fire B diagnosis	P0314	Single cylinder misfire	Mis fire detected

Electronic control unit connector illustration:

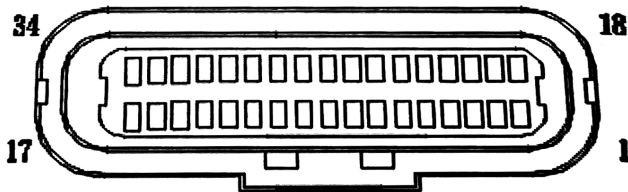

Power supplies	6
Sensors inputs	6
Logic inputs	4
Differential inputs	2
Power outputs	12
Communication	2
cConfigurable IO	2

X34	X33	X32	X31	X30	X29	X28	X27	X26
Vehicle Speed	-	SENSOR supply	Kill Sw	VBD	CAN_L	SAV	(H)EGO SENS_UP	SENSOR GROUND
FAN relay	-	RPM OUT	-	FSU/FP relay	CAN_H	VBK	(H)EGO SENS_DN	-
X17	X16	X15	X14	X13	X12	X11	X10	X9

X25	X24	X23	X22	X21	X20	X19	X18
VR-	start relay	CHTS	CPV	SSW	IGNITION COIL	MIL	PGND2
VR+	head lamp relay	START SW	Injector PI	-	HEGO HEAT_UP	-	PGND1
X8	X7	X6	X5	X4	X3	X2	X1

MECHANISM DIAGRAM	5-1	ENGINE SUSPENSION FRAME.....	5-7
OPERATIONAL PRECAUTIONS	5-2	INSTALLATION OF ENGINE	5-8
ENGINE REMOVAL	5-3		
REMOVAL OF ENGINE SUSPENSION BUSHING	5-6		

MECHANISM DIAGRAM

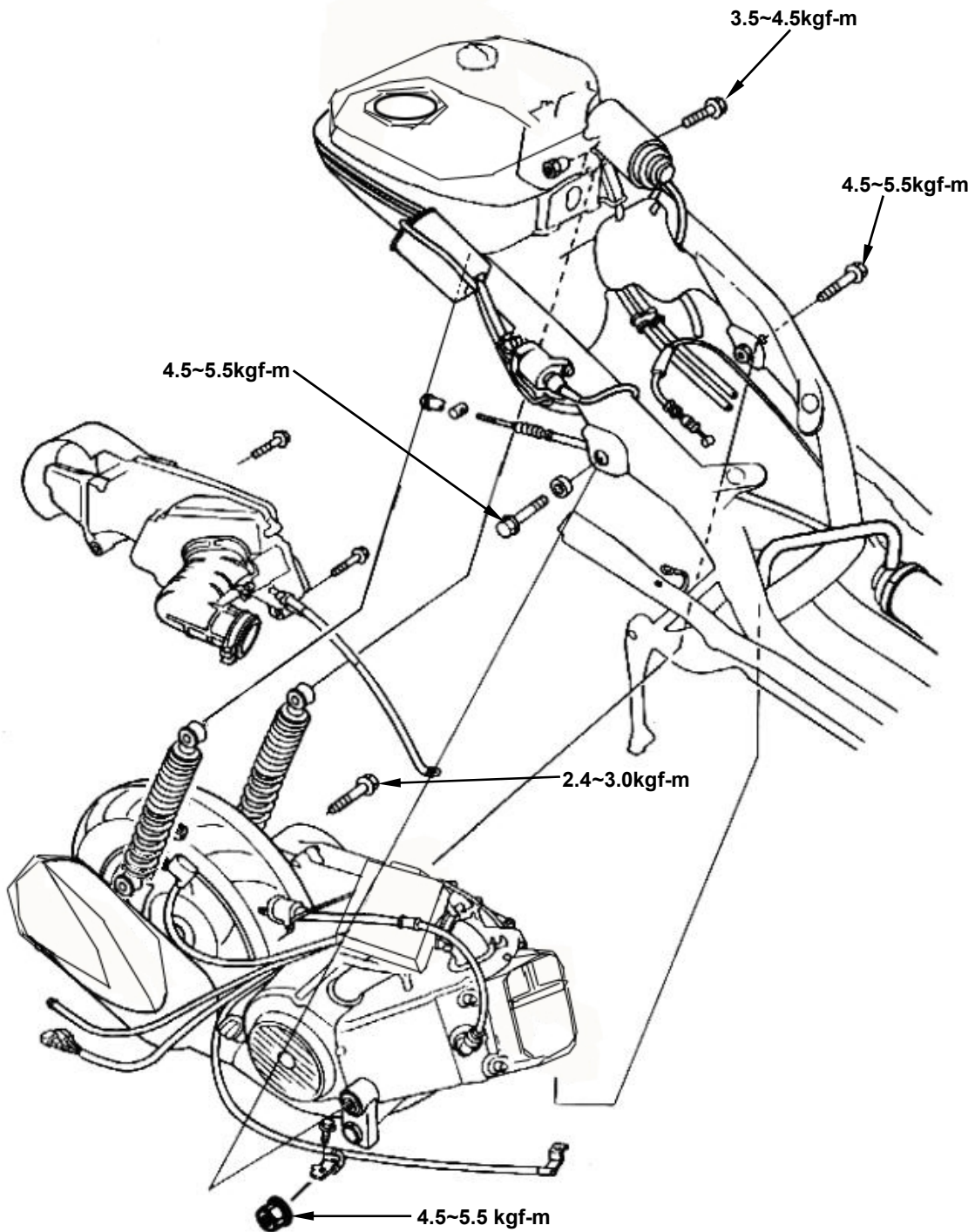

OPERATIONAL PRECAUTIONS**General Information**

- Engine must be supported by a bracket or adjustable tool in height.
- The following parts can be serviced with the engine installed on the frame.
 1. Carburetor
 2. Driving disk, driving belt, clutch, and transporting disk
 3. Final reduction gear mechanism

Specification

Item		Specification
Engine Oil Capacity	Replacement	950 c.c.
	Disassemble	700 c.c.
Gear Oil Capacity	Replacement	180 c.c.
	Disassemble	170 c.c.

Torque Values

Engine suspension bolt (frame side)	4.5~5.5kgf-m
Engine suspension nut (engine side)	4.5~5.5kgf-m
Bolt of rear shock absorber upper connection	3.5~4.5kgf-m
Bolt of rear shock absorber lower connection	2.4~3.0kgf-m

ENGINE REMOVAL

Open the seat.

Remove the rear carrier (3 bolts).

Remove the luggage box assembly (4 bolts).

Remove the body cover (4 screws, 3 bolts).

Remove the power connector of auto by-start.

Remove the generator connector and pulse generator connector.

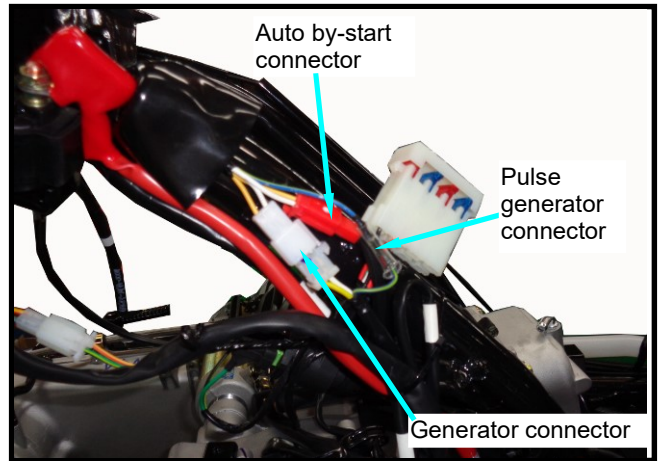

Remove the starter motor wire on the Starter magnetic switch.

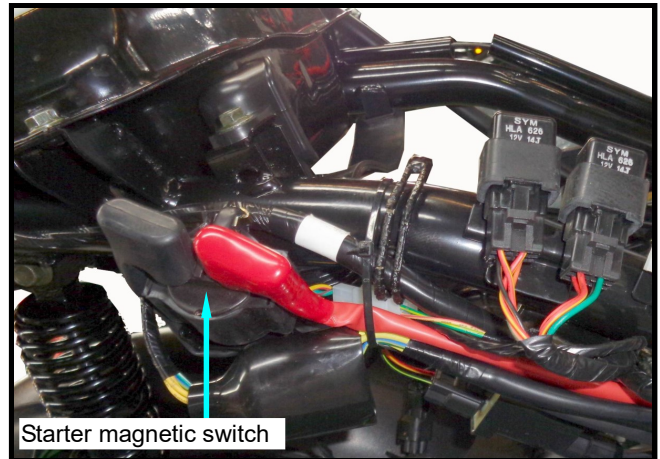

Remove the spark plug cap.

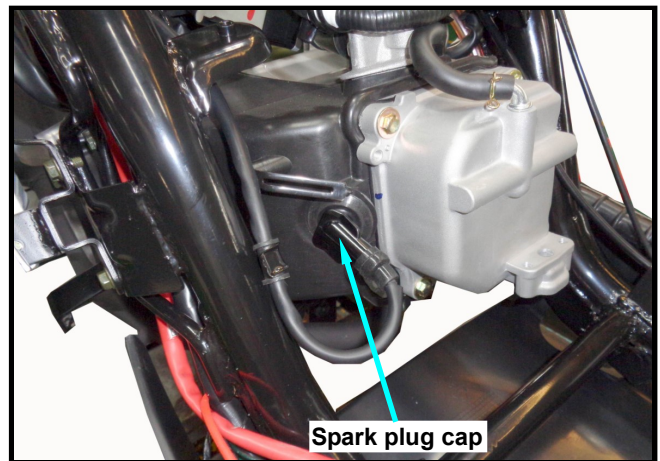

Remove the vacuum hose, and throttle valve cable from the ECU SET.

Loose the strap screw of the air cleaner guide, and remove the air cleaner guide

Remove the throttle cable

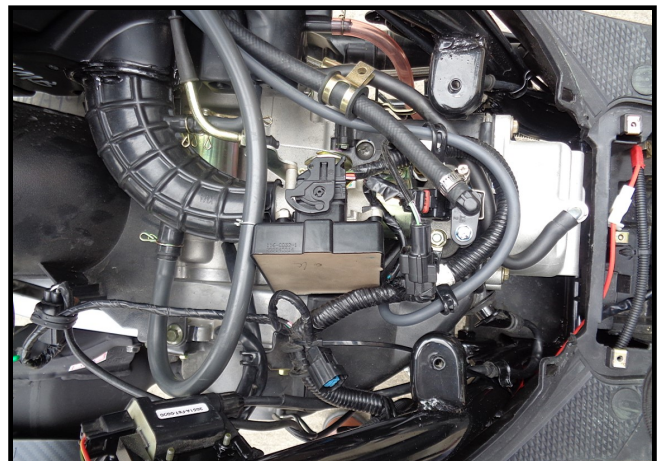

5. REMOVAL OF ENGINE

SYM

Remove the fuel tube. Remove cylinder head TEMP sensor connector.
Start engine for the pipeline to be exhausted
Within the residual pressure, the engine flameout, relaxing fuel tube folder, open for fuel tube.

Caution

- Demolition for the pipeline will be required for residual pressure in the pipeline to divest, or use the folder surrounds the tubing to prevent petrol splash.

Remove the exhaust muffler (Bolts \times 3, Cap Nuts \times 2).

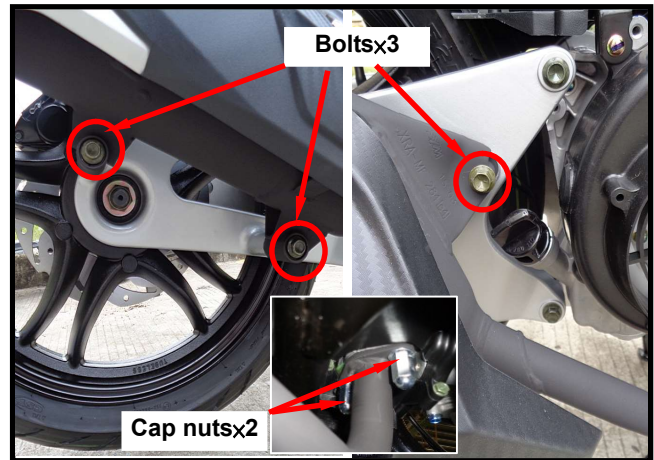
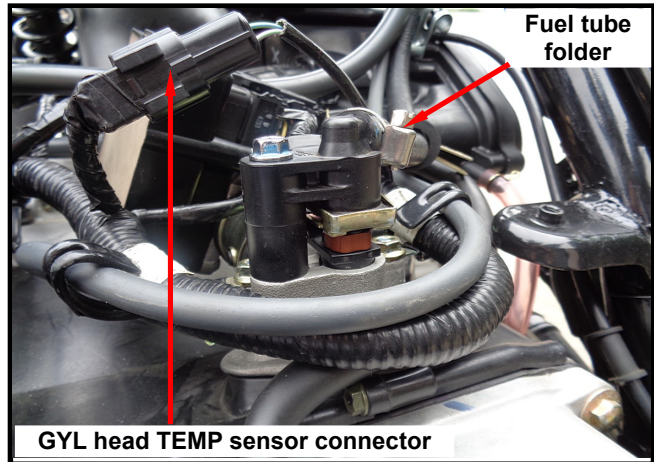

Remove the rear wheel (Nut \times 1).

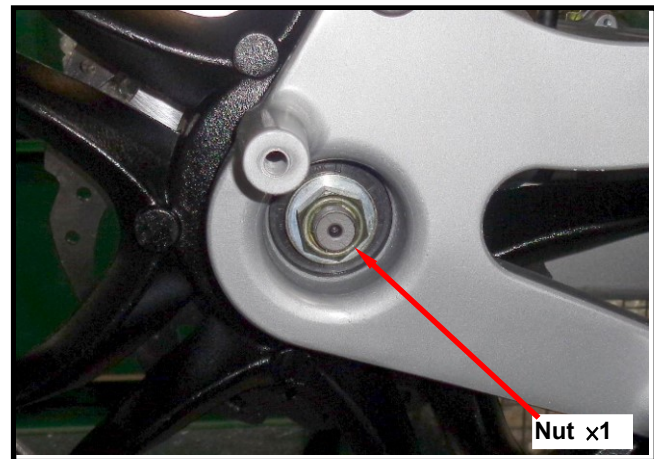

Remove the air cleaner connection bolts (2 bolts).

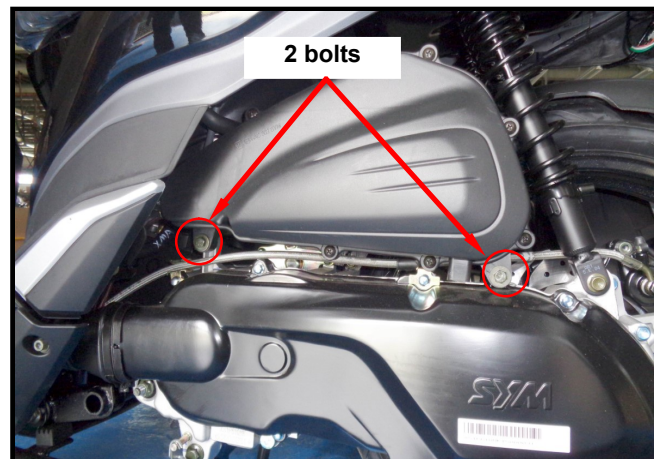

Remove the rear brake nut.
Remove the rear brake caliper
Remove the rear shock absorber lower bolt.

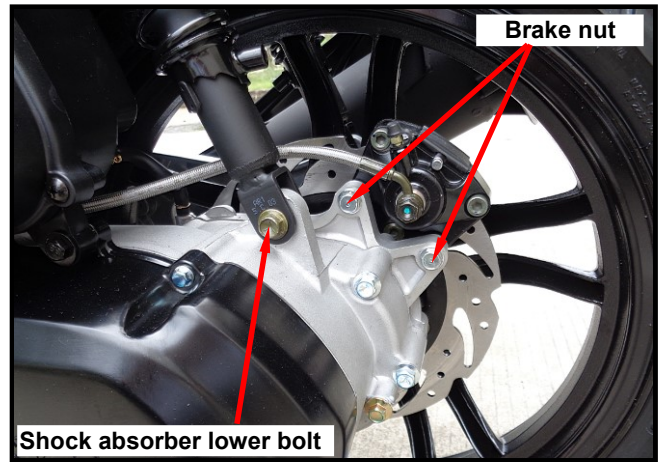

Loose the strap screw of engine left guide, and then remove the engine left guide.

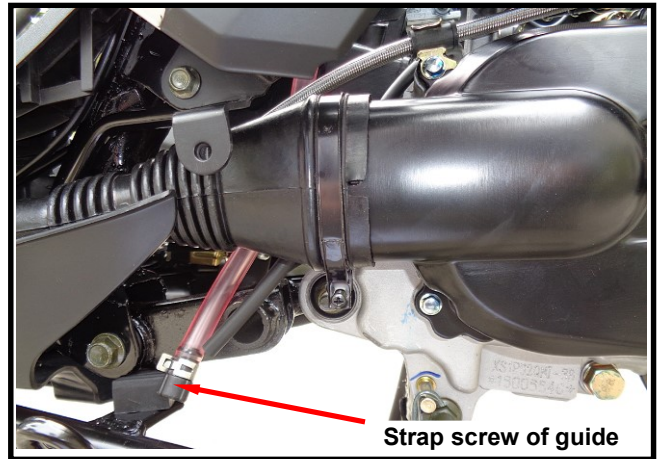

Remove the engine suspension nuts and bolts (engine side), and then remove the engine.

⚠ Caution

- With a bracket to support the engine to prevent from it damage by falling down as removing the engine.

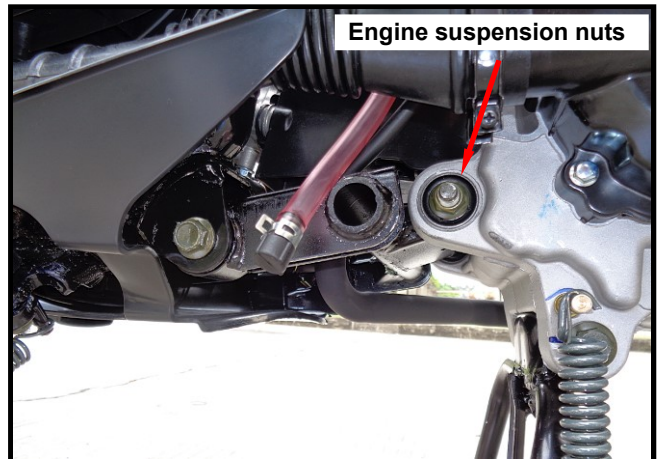

Check if the engine suspension, rear shock absorber bushing, and cushion rubber for damage. Replace them with new ones if so.

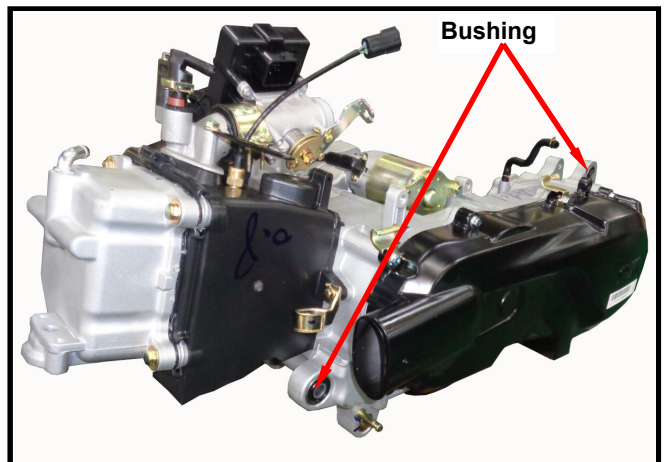

REMOVAL OF ENGINE SUSPENSION BUSHING

If engine suspension frame and the cushion rubber of rear shock absorber bushing damaged. Then, with the bushing remover / presser, $\Phi 28\text{mm}$ & $\Phi 20\text{mm}$, to press the bushing out, and replace it with new one.

Engine suspension bushing: $\Phi 28\text{mm}$

Rear shock absorber bushing: $\Phi 20\text{mm}$



Pressing out

Place the detent section of the bushing remover toward the bushing, and drive both the pressing ring and bolt in to press the bushing out.



Pressing In

Place the flat section of the remover toward the bushing, and then drive the bushing, pressing ring, and bolt in to install the bushing.

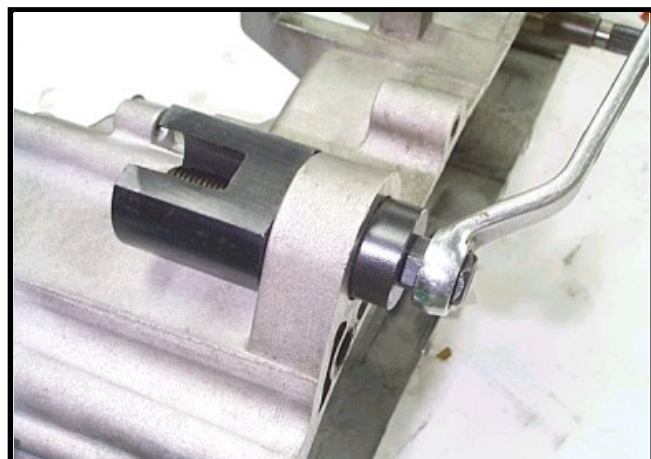
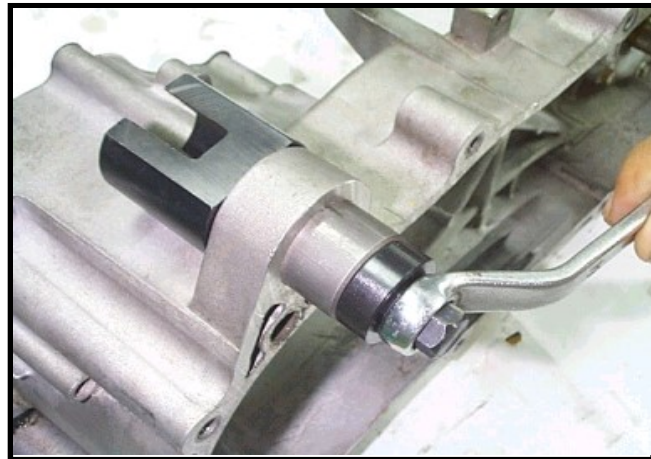

ENGINE SUSPENSION FRAME**Removal**

Remove the left side bolt of engine suspension frame.

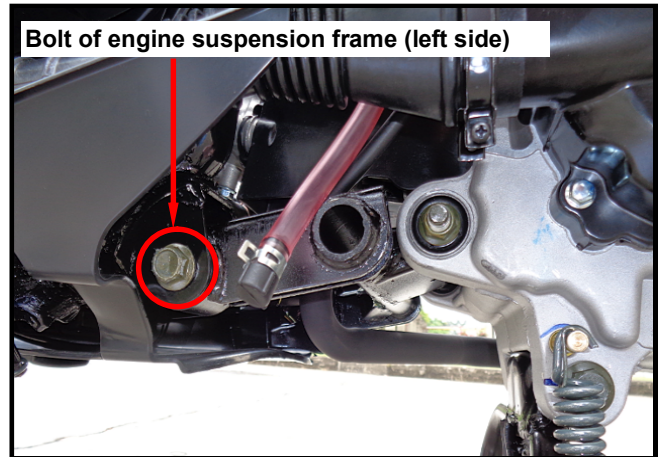

Remove the right side bolt of engine suspension frame.

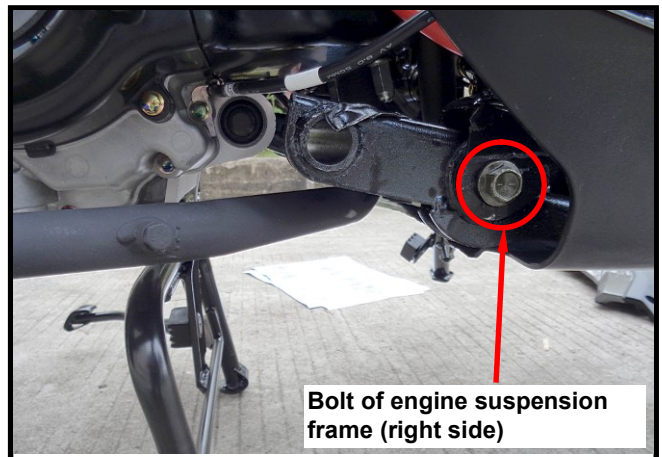

Check if the engine suspension frame bushing and cushion rubber for damage. If so, replace with new ones.

Installation

Tighten the bolts and nuts of engine suspension frame.

Engine suspension frame nut:
Torque Value: 4.5~5.5 kgf-m

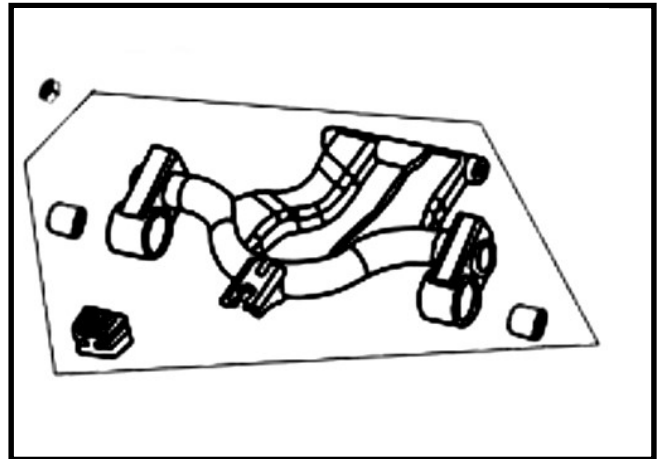

INSTALLATION OF ENGINE

Check if the bushings of engine suspension frame and shock absorber for damaged. If so, replace with new ones.

Install the engine according to the reversing order of removal.

Caution

- Notice both feet and hands safety for squeezing as engine installation.
- Do not bent or squeeze each wires or hose.
- Route all cables and wires in accordance with the routine layout.

Engine suspension nut:

Torque Value: 4.5~5.5kgf-m

Rear shock absorber bolt:

Torque Value: Top: 3.5~4.5kgf-m

lower: 2.4~3.0kgf-m

Rear wheel axle nut:

Torque Value: 11.0~13.0kgf-m

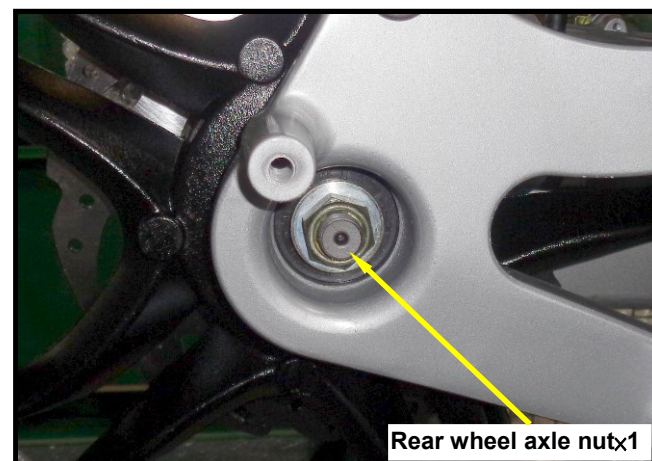
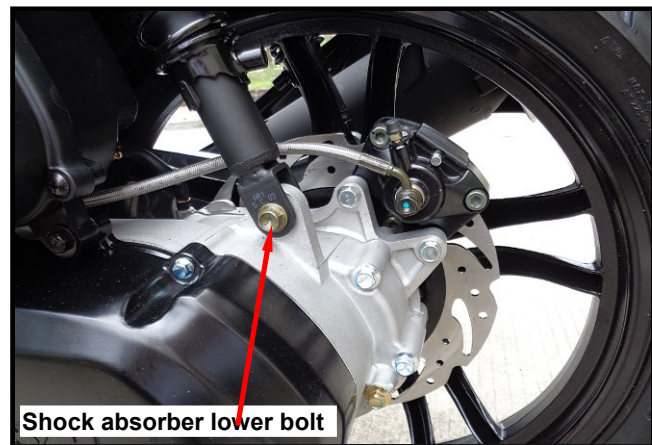
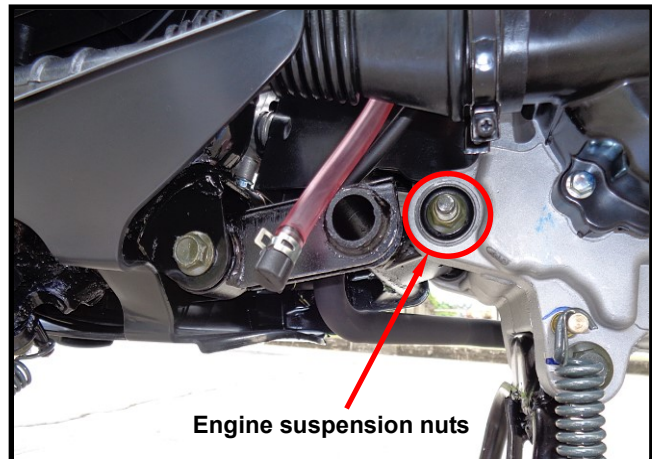

MECHANISM DIAGRAM	6-1	CYLINDER HEAD INSPECTION	6-7
PRECAUTIONS IN OPERATION	6-2	VALVE SEAT INSPECTION AND	
TROUBLE SHOOTING.....	6-3	SERVICE.....	6-9
CAMSHAFT REMOVAL	6-4	CYLINDER HEAD REASSEMBLY	6-11
CYLINDER HEAD REMOVAL	6-6	CYLINDER HEAD INSTALLATION.....	6-12
CYLINDER HEAD DISASSEMBLY	6-6	VALVE CLEARANCE ADJUSTMENT ..	6-13

MECHANISM DIAGRAM

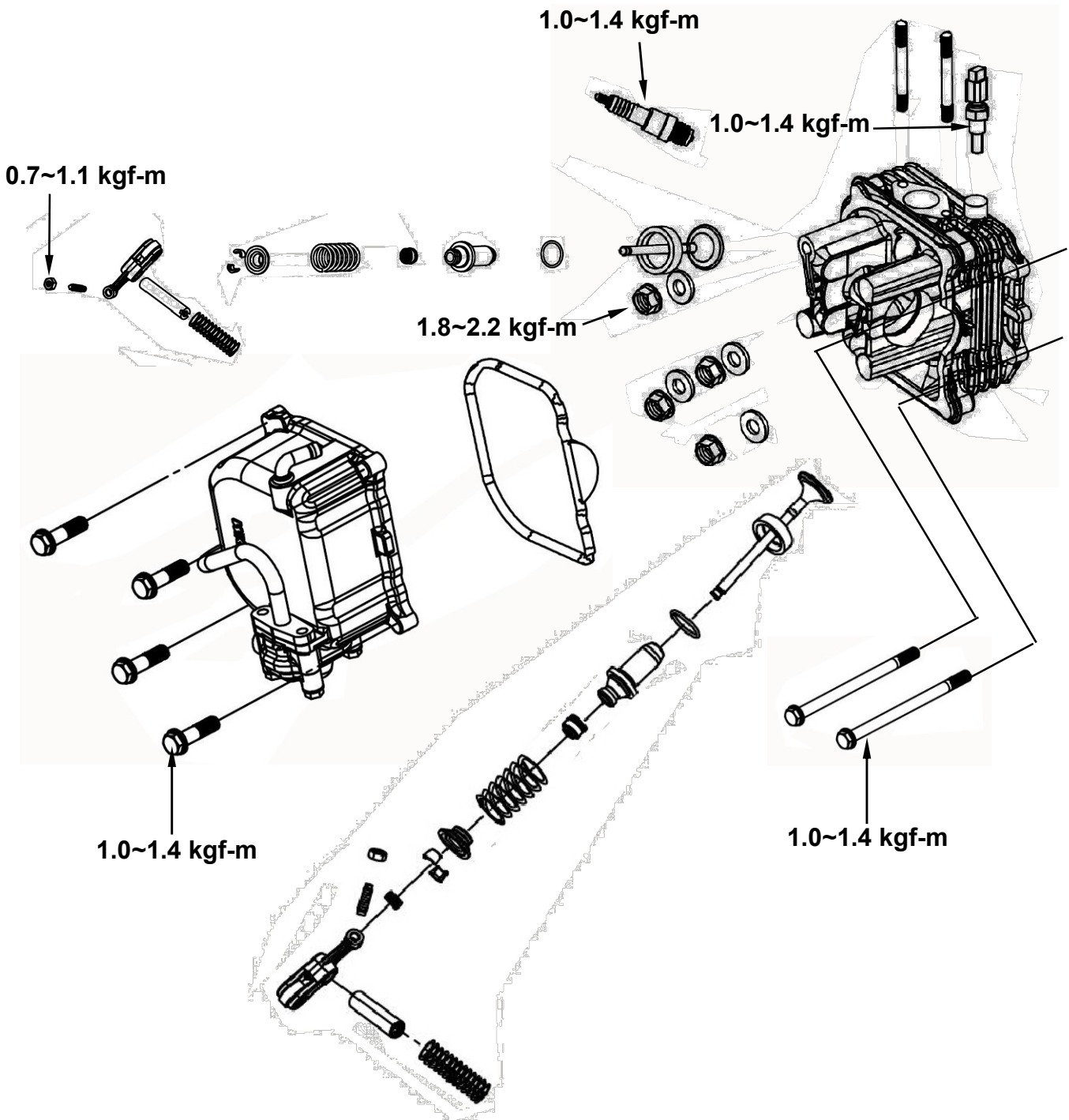

PRECAUTIONS IN OPERATION**General Information**

- This chapter is contained maintenance and service for cylinder head, valve, and camshaft as well as valve rocker arm.
- Cylinder head service cannot be carried out when engine is in frame.

Specification

unit: mm

Item		Standard	Limit
Compression pressure		10.3 ± 0.2:1 kg/cm ²	-
Camshaft	Height of cam lobe	Intake	20.231
		Exhaust	19.907
Rocker arm	ID of valve rocker arm		10.00~10.015
	OD of valve rocker arm shaft		9.972~9.987
Valve	OD of valve stem	Intake	4.970~4.980
		Exhaust	4.955~4.970
	ID of Guide		5.00~5.012
	Clearance between valve stem and guide	Intake	0.020~0.042
		Exhaust	0.030~0.057
	Free length of valve spring	Outer	35.250
		Inner	32.410
	Valve seat width		1.000

Torque Value

Cylinder head cover bolt	0.8~1.2kgf-m
Cylinder head bolt (LH)	0.7~1.1kgf-m
Sealing screw of timing chain auto-adjuster	0.8~1.2kgf-m
Bolt of timing chain auto-adjuster	1.0~1.4kgf-m
Cam sprocket bolts	0.7~1.1kgf-m (apply with oil on bolt thread & seat)
Spark plug	1.0~1.4kgf-m
Cylinder head temperature sensor	1.0~1.4kgf-m

TOOLS**Special service tools**

Valve reamer: 5.0mm
 Valve guide driver: 5.0mm
 Valve spring compressor

TROUBLE SHOOTING

Engine performance will be effected by troubles on engine top end. The troubles usually can be determinate or by performing cylinder compression test and judging the abnormal noise generated.

Rough Idle

Low compression pressure.

Low compression pressure**1. Valve**

- Improper valve adjustment.
- Burnt or bended valve.
- Improper valve timing.
- Valve spring damaged.
- Valve carbon.
- Poor sealing on valve seat.
- Improper spark plug installation.

2. Cylinder head

- Cylinder head gasket leaking or damage.
- Tilt or crack cylinder surface.

3. Piston

- Piston ring worn out.

High compression pressure

- Too much carbon deposit on combustion chamber or piston head.

Noise

- Improper valve clearance adjustment
- Burnt valve or damaged valve spring
- Camshaft wear out or damage
- Cam chain wear out or looseness
- Auto-adjuster wear out or damage of cam chain
- Camshaft sprocket wear out
- Rocker arm or rocker arm shaft wear out

White smoke

- Valve guide or valve stem wear out
- Valve stem seal wear out

CAMSHAFT REMOVAL

Remove the shroud of the engine.
 Remove the crankcase blow-by system hose from the cylinder head.
 Remove the cylinder head cover 4 bolts and then remove the cylinder head cover.

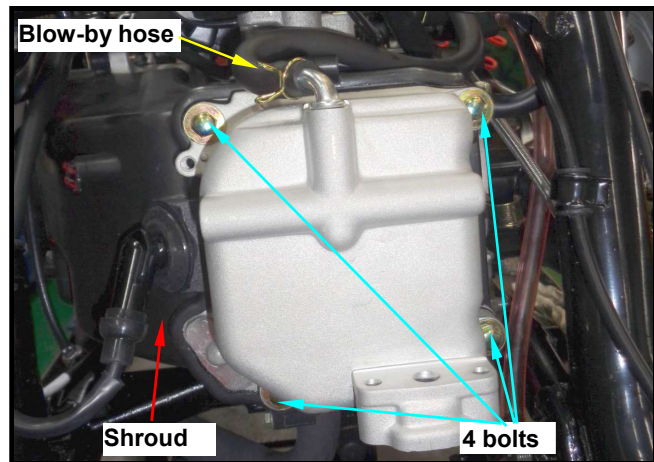

Loosen the screw of camshaft chain adjuster and remove O-ring.
 With a flat screwdriver to tighten the screw of camshaft chain adjuster in a clockwise motion for release adjuster.

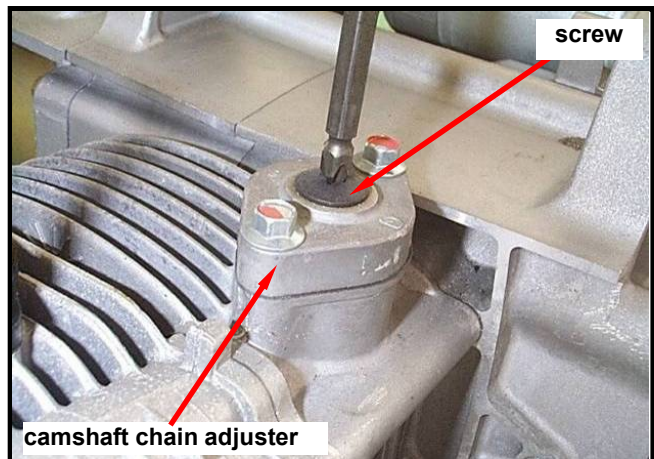

Turn the flywheel in counter-clockwise motion with T type wrench until the "T" mark on flywheel aligned with the mark on the crankcase so that the hole on the camshaft sprocket is forward up and piston is at TDC position.

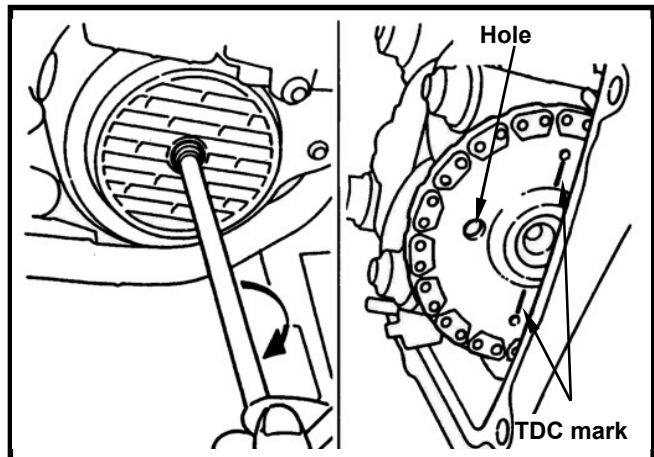

Remove camshaft holder nut and washer.

⚠ Caution

Loosen the nuts diagonally by 2-3 sequences.

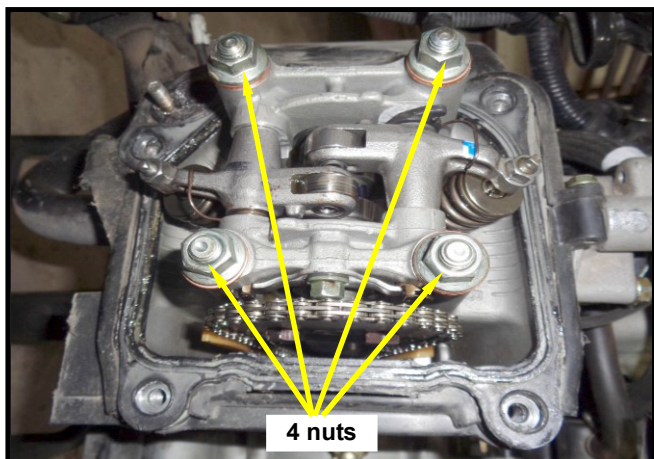

Remove the camshaft holder and rocker arm set.
 Remove the camshaft chain from the camshaft sprocket.
 Remove the cylinder head.

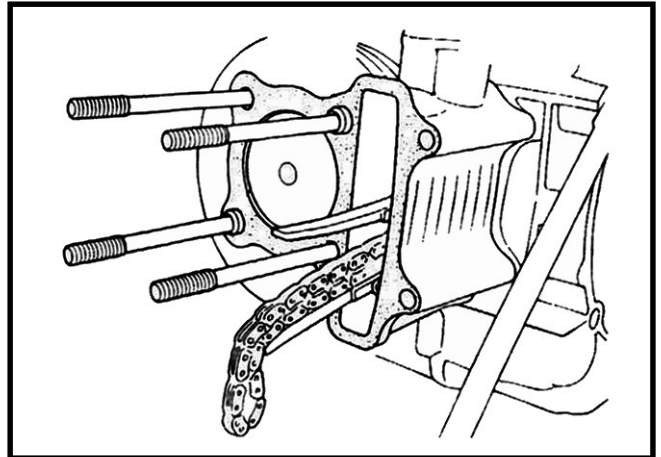

Camshaft Inspection

Inspect cam lobe height for damaged.

Service Limit

IN: Replacement when less than 20.570mm

EX: Replacement when less than 19.410 mm

Inspect the camshaft bearing for looseness or wear out. If any, replace whole set of camshaft and bearing.



Measure the valve rocker arm I.D.

Service Limit: Replace when it is above 10.100 mm

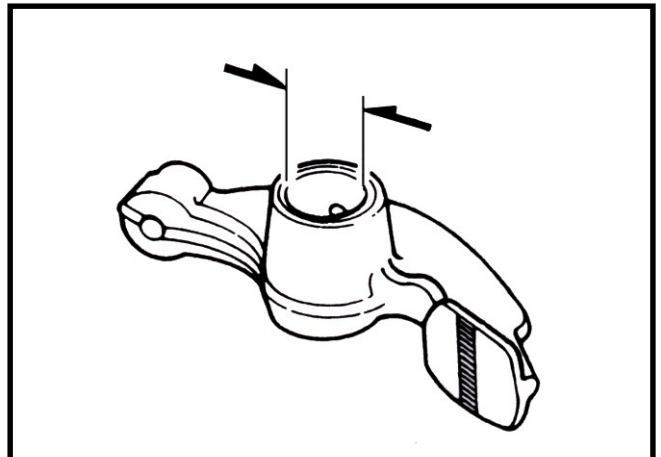

Measure the active O.D. of the valve rocker arm shaft .

Service Limit: Replace when it is above 9.910 mm

Calculate the clearance between the rocker arm shaft and the rocker arm.

Service Limit: Replace when it is above 0.10 mm

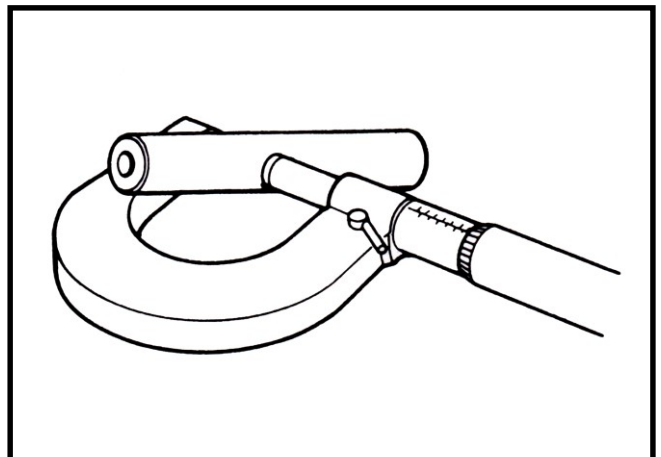

CYLINDER HEAD REMOVAL

Remove the engine (refer to Chapter 5).
 Remove the cooling fan cover.
 Remove the engine shroud .

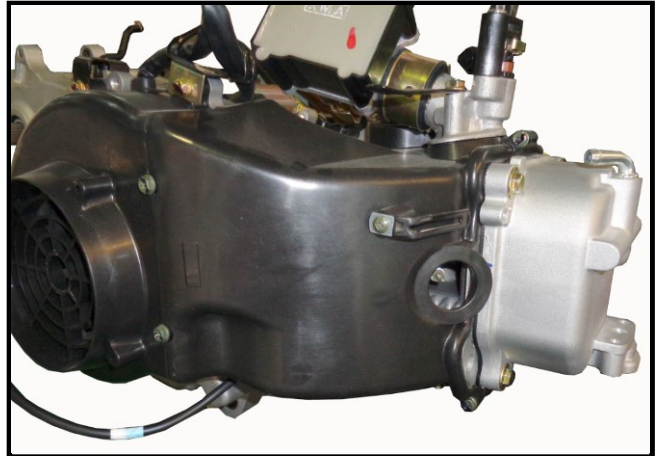

Remove the camshaft sprocket.

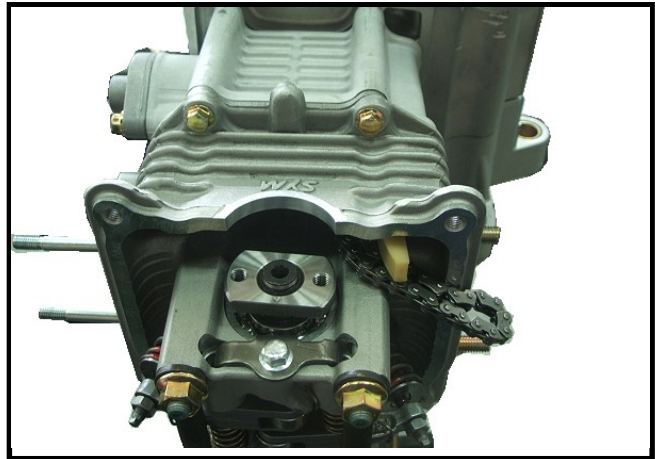

Remove the 2 cylinder head mounting bolts from cylinder head left side cover.
 Remove cylinder head gasket and 2 dowel pins.
 Remove chain plate.
 Clean up residues from the matching surfaces of cylinder and cylinder head.

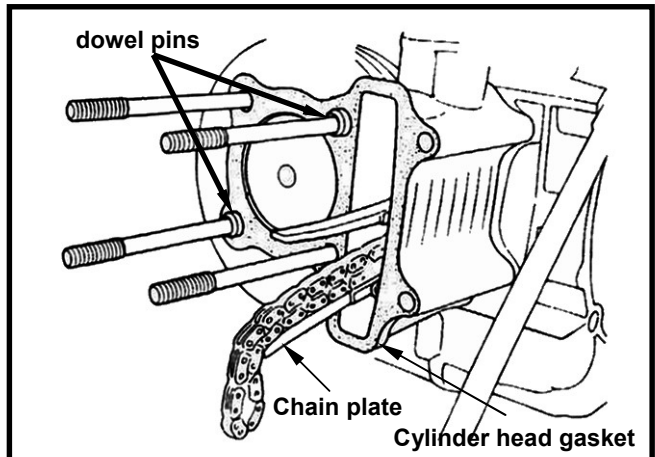

⚠ Caution

- Do not damage the matching surfaces of cylinder and cylinder head.
- Avoid residues of gasket or foreign materials falling into crankcase as cleaning.

CYLINDER HEAD DISASSEMBLY

Use a valve compressor to press the valve spring.

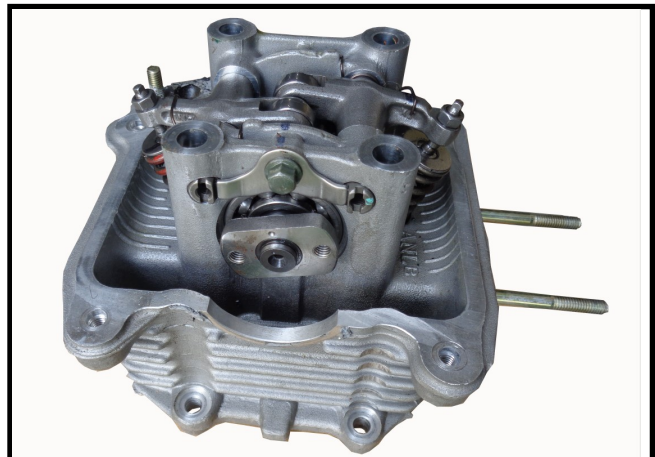

After removed valve cotters, release the compressor and then take out spring retainer, valve spring and valves.

⚠ Caution

In order to avoid to loosing spring tension, do not compress the spring too much. Its length is based on the installation of latch.

Special Service Tool: Valve spring compressor.

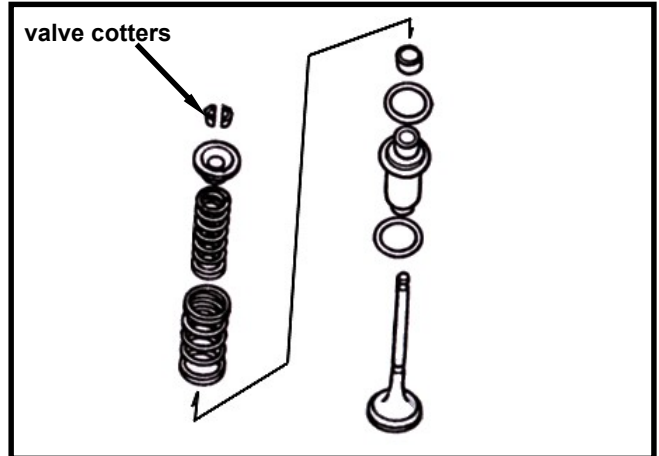

Remove valve stem guide seal.
Clean carbon deposits in combustion chamber.
Clean residues and foreign materials on cylinder head matching surface.

⚠ Caution

Do not damage the matching surface of cylinder head.

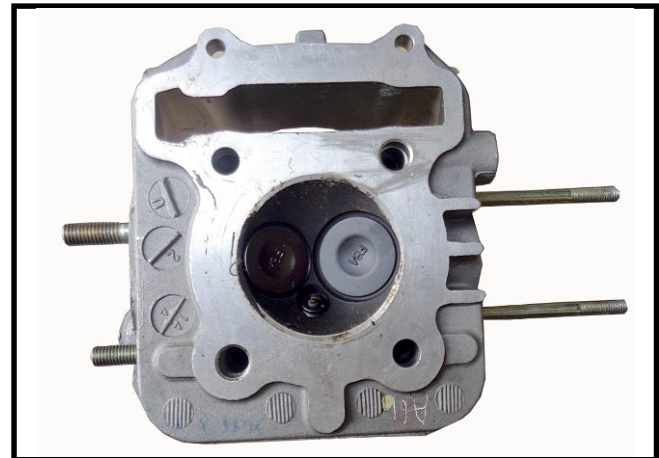

CYLINDER HEAD INSPECTION

Check if spark plug and valve holes are crack.
Measure cylinder head flat with a straightedge and flat feeler gauge.
Service limit: 0.05mm

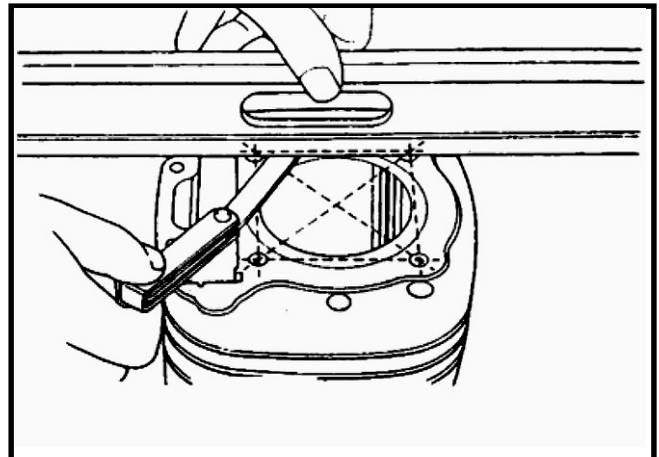

Valve spring free length

Measure the free length of intake and exhaust valve springs.

Standard

Outer : 35.250 mm

Inner : 32.410 mm

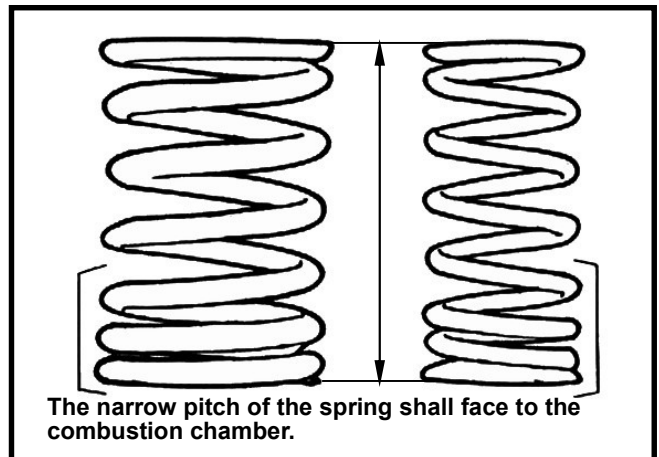

Valve stem

Check if valve stems are bend, crack or burn. Check the operation condition of valve stem in valve guide, and measure & record the valve stem outer diameter.

Service Limit: IN→ 4.900mm

EX→ 4.900mm

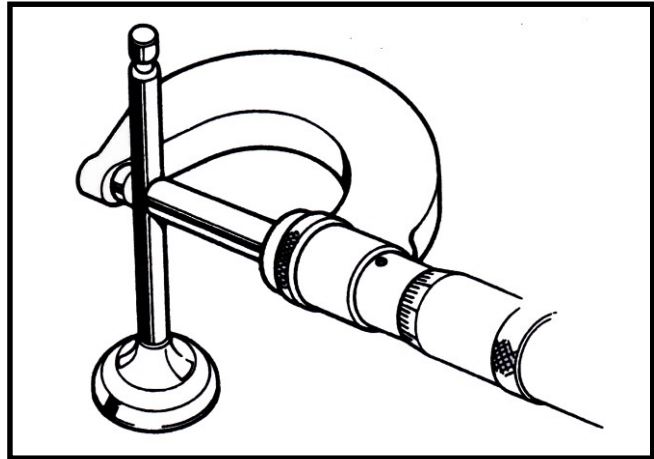

Valve guide

⚠ Caution

Before measuring the valve guide, clean carbon deposits with reamer.

Special Service Tool: 5.0mm valve guide reamer

Measure and record each valve guide inner diameters.

Service limit: 5.030mm

The difference that the inner diameter of valve guide deducts the outer diameter of valve stem is the clearance between the valve stem and valve guide.

Service Limit: IN→ 0.08mm

EX→ 0.10mm

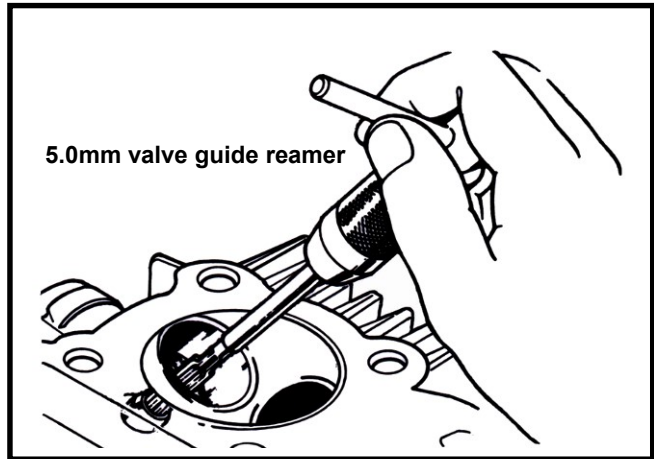

⚠ Caution

If clearance between valve stem and valve guide exceeded service limit, check whether the new clearance that only replaces new valve guide is within service limit or not. If so, replace valve guide.

Correct it with reamer after replacement. If clearance still exceeds service limit after replaced valve guide, replace valve stem too.

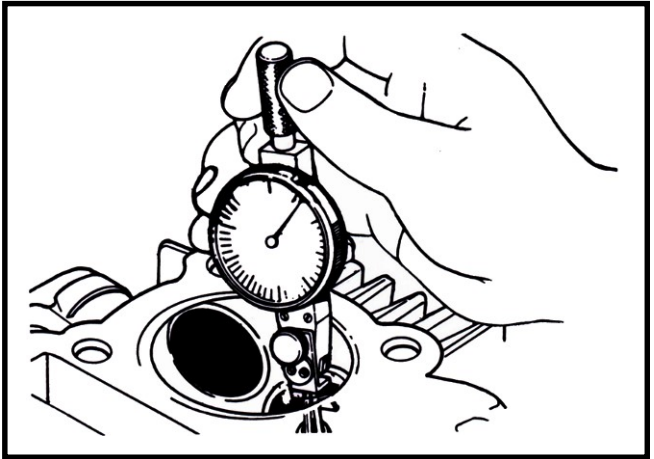

⚠ Caution

It must correct valve seat when replacing valve guide.

Valve guide replacement

Heat up cylinder head to 100~150 °C with heated plate or toaster.

⚠ Caution

- Do not let torch heat cylinder head directly. Otherwise, the cylinder head may be deformed as heating it.
- Wear on a pair of glove to protect your hands when operating.

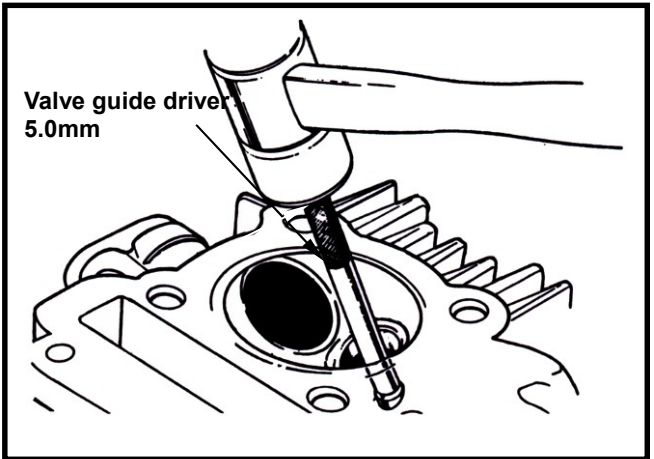

Hold the cylinder head, and then press out old valve guide from combustion chamber side.

Tool: Valve guide driver 5 mm

⚠ Caution

- Check if new valve guide is deformation after pressed it in.
- When pressing in the new valve guide, cylinder head still must be kept in 100~150 °C.

Adjust the valve guide driver and let valve guide height is in 13mm.

Press in new valve guide from rocker arm side.

Tool: Valve guide driver 5 mm

Wait for the cylinder head cooling down to room temperature, and then correct the new valve guide with reamer.

⚠ Caution

- Using cutting oil when correcting valve guide with a reamer.
- Turn the reamer in same direction when it be inserted or rotated.

Correct valve seat, and clean up all metal residues from cylinder head.

Special tool: Valve guide reamer 5 mm

VALVE SEAT INSPECTION AND SERVICE

Clean up all carbon deposits onto intake and exhaust valves.

Apply with emery slightly onto valve contact face. Grind valve seat with a rubber hose or other manual grinding tool.

⚠ Caution

- Do not let emery enter into between valve stem and valve guide.
- Clean up the emery after corrected, and apply with red paint onto contact faces of valve and valve seat.

Remove the valve and check its contact face.

⚠ Caution

Replace the valve with new one if valve seat is roughness, wear out, or incomplete contacted with valve seat. If the valve and the valve seat still can not be matched sealing after grinded, replace it with new one.

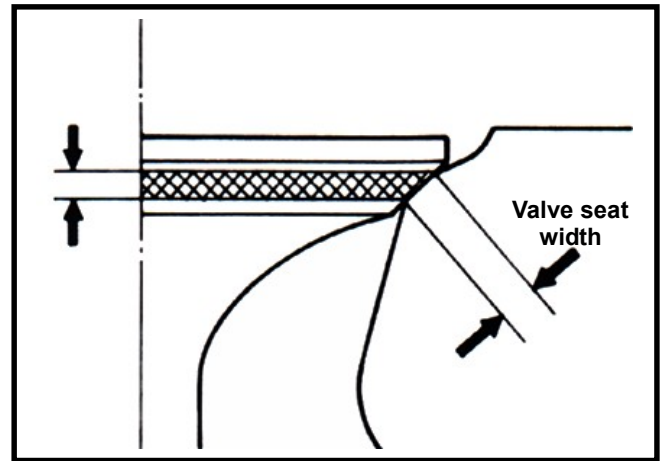
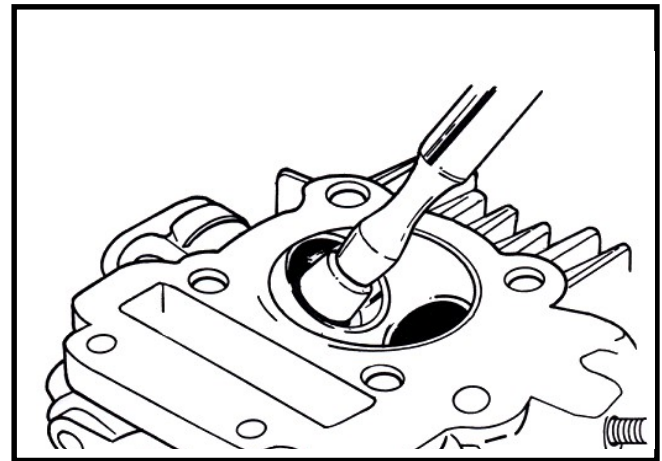
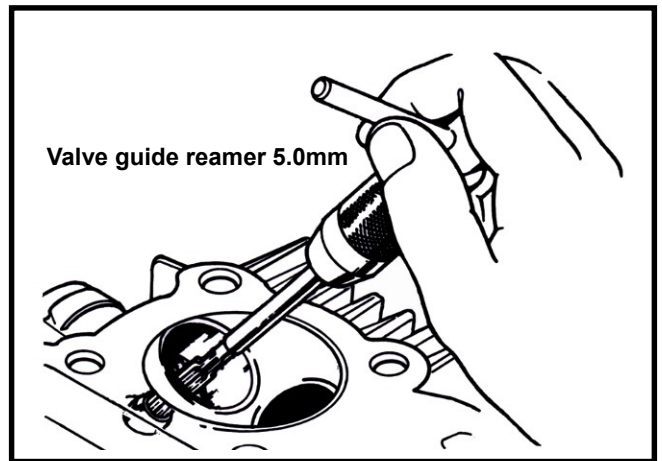
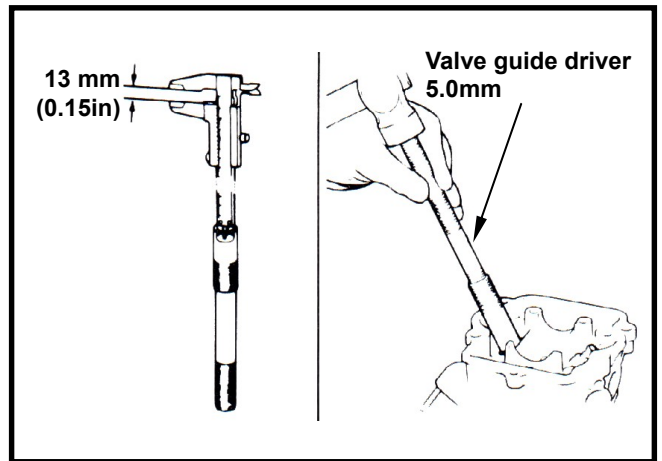

Valve seat inspection

If the valve seat is too wide, narrow or rough, correct it.

Valve seat width

Service limit: 1.6mm

Check the contact condition of valve seat.

Valve seat grinding

The worn valve seat has to be grinded with valve seat chamfer cutter.

Use 45° valve seat chamfer cutter to cut any rough or uneven surface from valve seat.

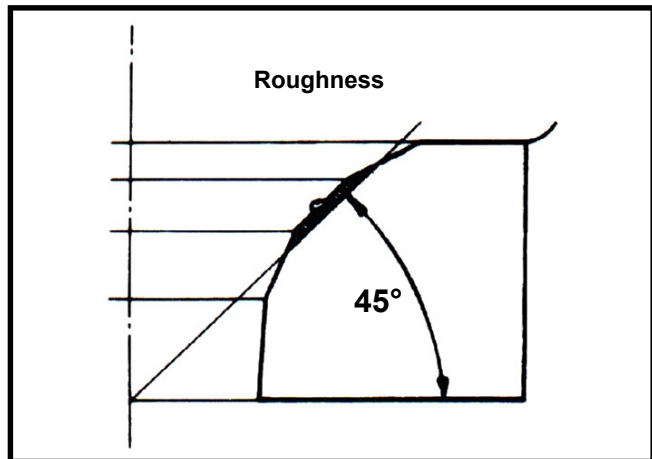

⚠ Caution

After valve guide had been replaced, it has to be grinded with 45° valve seal chamfer cutter to correct its seat face.

Use 32° cutter to cut a quarter upper part out.

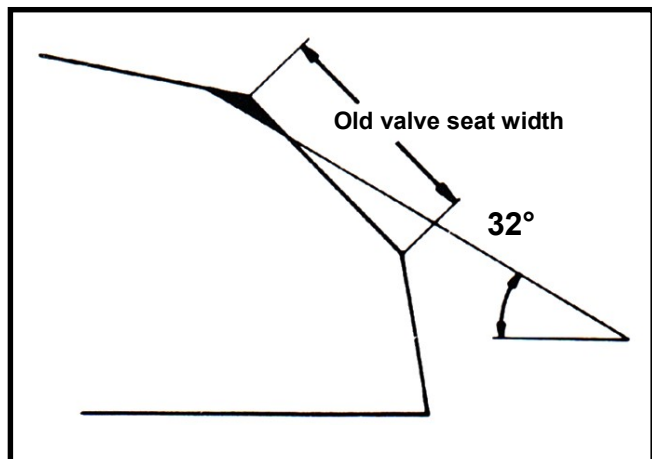

Use 60° cutter to cut a quarter lower part out. Remove the cutter and check new valve seat.

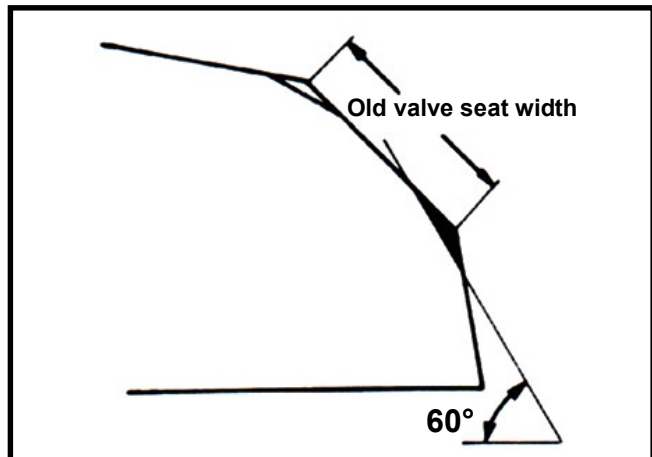

Use 45° cutter to grind the valve seat to specified width.

⚠ Caution

Make sure that all roughness and uneven faces had been grinded.

Grind valve seat again if necessary.

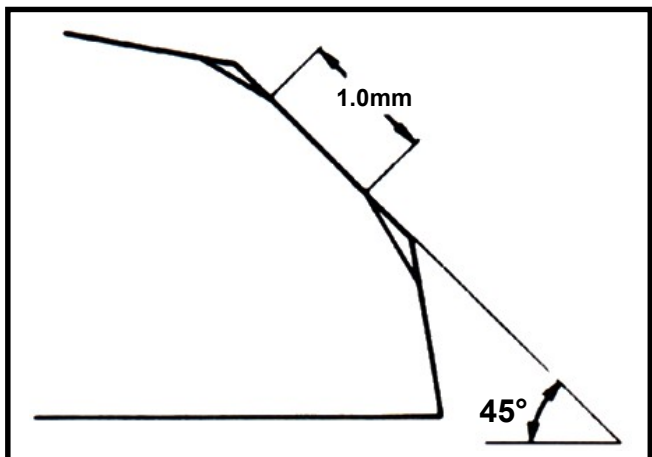

Coat the valve seat surface with red paint. Install the valve through valve guide until the valve contacting with valve seat, slightly press down the valve but do not rotate it so that a seal track will be created on contact surface.

⚠ Caution

The contact surfaces of valve and valve seat are very important to the valve sealing capacity.

If the contact surface too high, grind the valve seat with 32° cutter. Then, grind the valve seat with 45° cutter to specified width.

If the contact surface too low, grind the valve seat with 60° cutter. Then, grind the valve seat with 45° cutter to specified width.

After the valve seat grinded, coat valve seat surface with emery and then slightly press the grinded surface. Clean up all emery coated onto cylinder and valve after grinded.

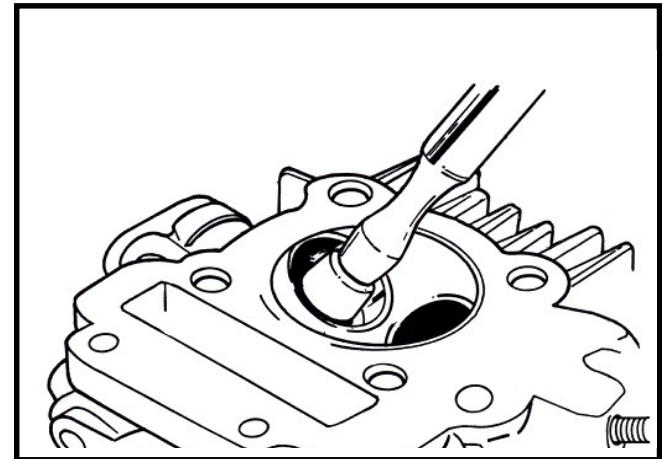
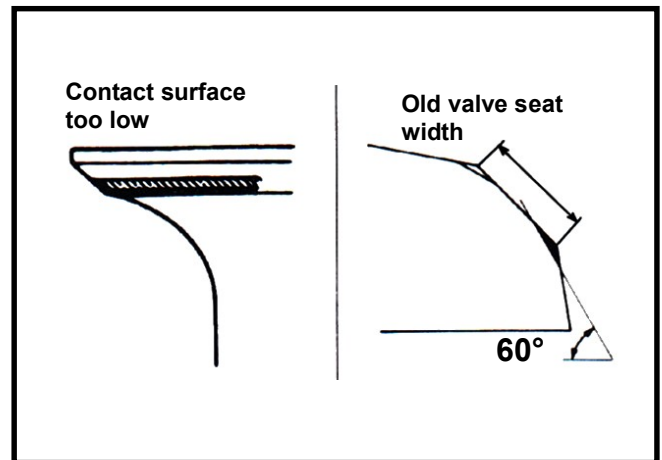
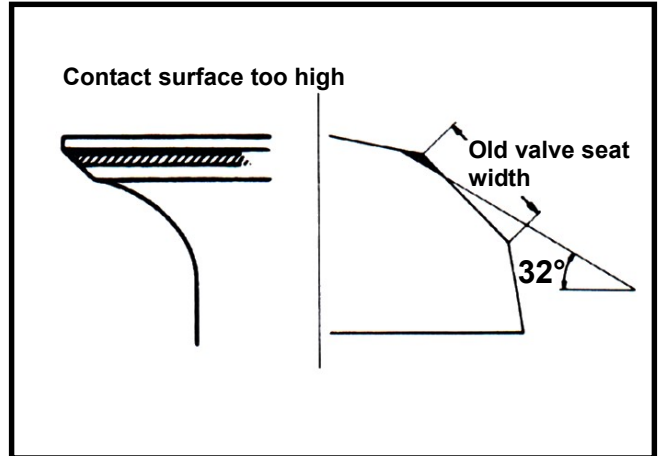

CYLINDER HEAD REASSEMBLY

Lubricate valve stem with engine oil, and then insert the valve into valve guide. Install new valve stem oil seal. Install valve springs and retainers.

⚠ Caution

The closed coils of valve spring should face down to combustion chamber.

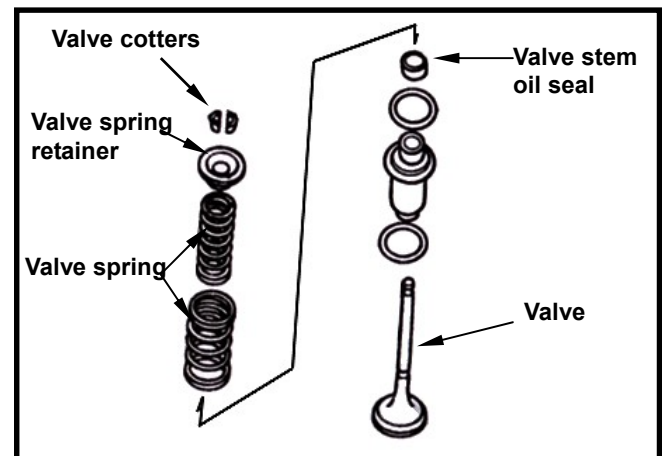

Use valve spring compressor to press valve spring.
Install valve split locks and release the valve compressor.

⚠ Caution

In order to avoid to loosing spring tension, do not compress the spring too much. Its length is based on the installation of latch.

Special tool: valve spring compressor

Tap valve stem to make valve retainer and valve stem sealing properly.

⚠ Caution

Place and hold cylinder head on to working table so that can prevent from valve damaged.

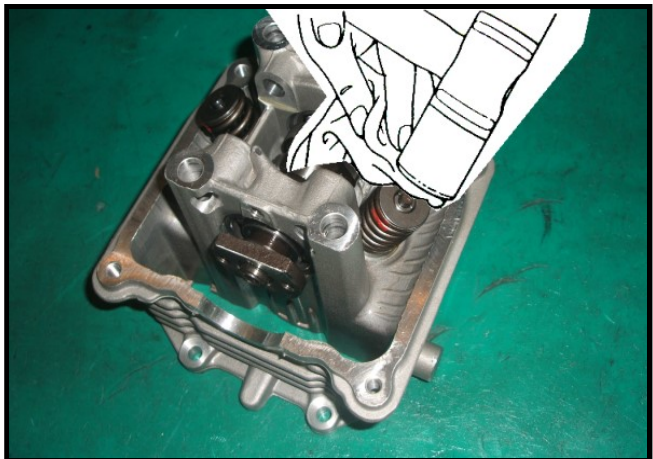
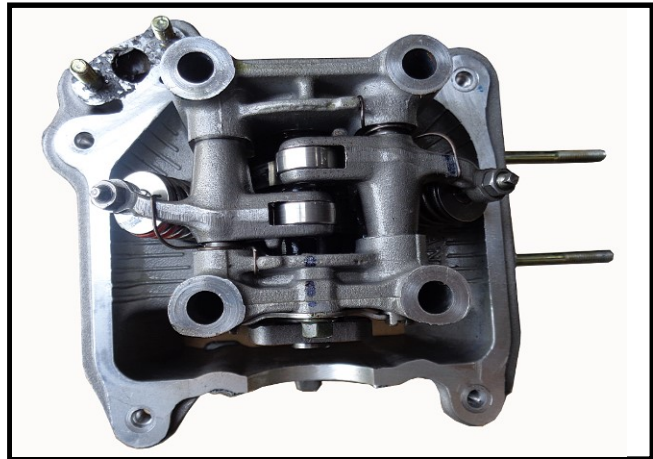

CYLINDER HEAD INSTALLATION

Install the lock pins and new cylinder head gasket onto the cylinder head.
Install the camshaft chain plate.

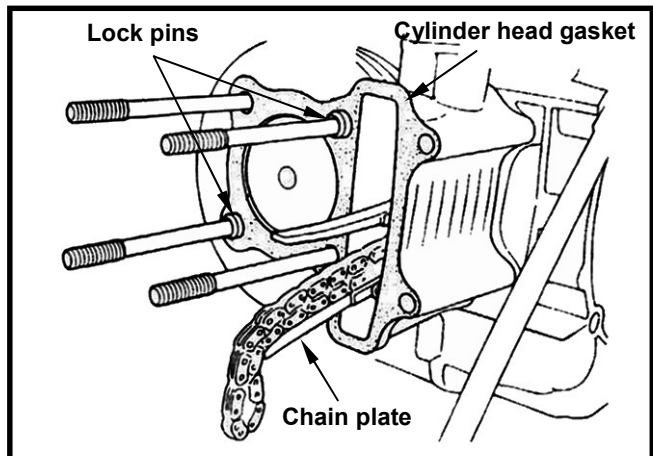

With T type wrench to turn crankshaft in a clockwise motion so that the "T" mark on the flywheel aligns with the mark on crankcase. (piston is at TDC position)
Place the TDC marks of the cam sprocket at same level of the top-end of cylinder head. The other single hole of the cam sprocket is in upward. Then, install the cam chain onto the cam sprocket.

Install the cylinder head.

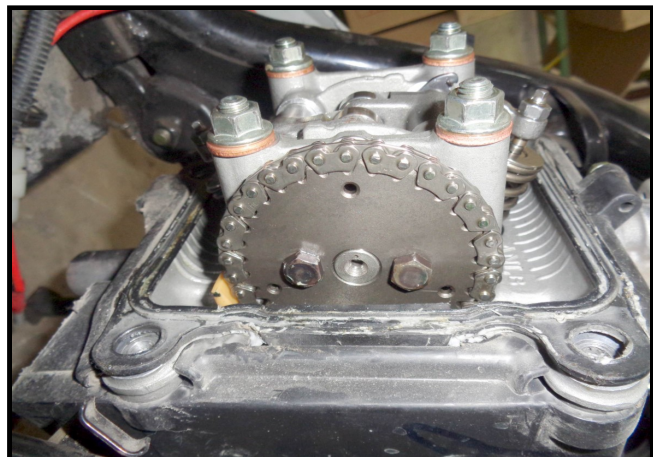

VALVE CLEARANCE ADJUSTMENT

Loosen valve clearance adjustment nuts and bolts located on valve rocker arm.

Measure and adjust valve clearance with feeler gauge.

After valve clearance had been adjusted to standard value, hold adjustment bolt and then tighten the adjustment nut.

Standard Value: $0.12 \pm 0.02\text{mm}$

With flat screwdriver, turn the cam sprocket adjuster in counter-clockwise motion so that the adjuster is pushed out to contact the cam chain plate tightly. Apply with oil onto a new O-ring and then install it onto the adjuster hole. Tighten the bolt cap of the adjuster adjustment hole.

⚠ Caution

The O-ring must be installed into glove.

Replace the O-ring of the cylinder head with new one. Install the cylinder head.

Tighten the cylinder head lock bolts.
Connect the blow-by hose onto the cylinder head.

Install the engine onto the engine frame.
(Refer to Chapter 5)

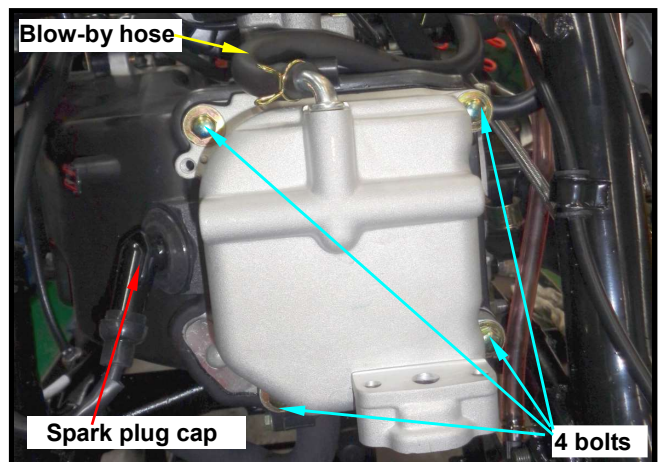
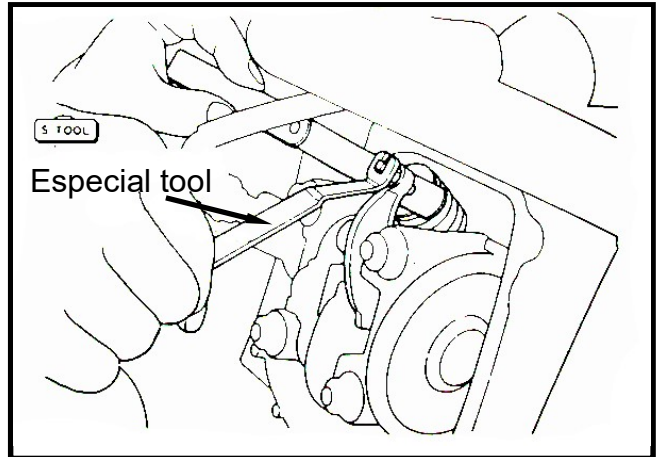

MECHANISM DIAGRAM7-1	PISTON REMOVAL.....7-5
PRECAUTIONS IN OPERATION7-2	PISTON RING INSTALLATION.....7-7
TROUBLE DIAGNOSIS.....7-2	PISTON INSTALLATION.....7-8
CYLINDER REMOVAL7-3	CYLINDER INSTALLATION..... 7-8

MECHANISM DIAGRAM

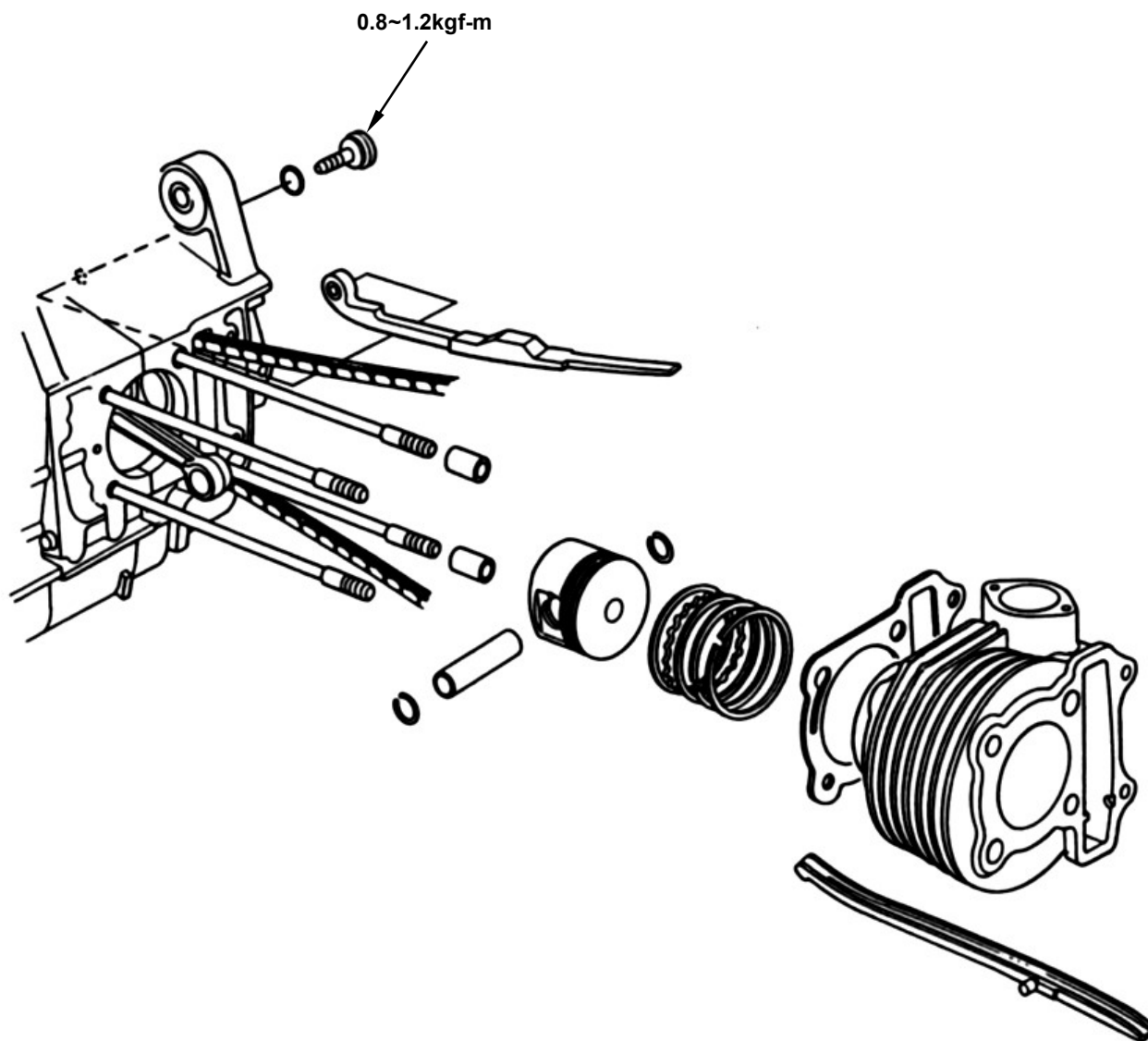

PRECAUTIONS IN OPERATION

General Information

- Both cylinder and piston service cannot be carried out when engine mounted on frame.

Specification

unit: mm

Item		Standard	Limit	
Cylinder	ID	52.395~52.415	52.50	
	Bend/wrap age	Less than 0.05	0.050	
	Roundness	Less than 0.01	0.050	
	Cylindrical	Less than 0.05	0.050	
Piston/ Piston ring	Clearance between piston and rings	Top ring	0.05~0.105	0.145
		2 nd ring	0.05~0.105	0.145
	Ring-end gap	Top ring	0.100~0.2500	0.500
		2 nd ring	0.300~0.500	0.750
		Oil ring	0.200~0.700	—
	OD of piston		52.385~52.405	52.310
	Piston OD measurement position		Lower-end up 7mm of piston skirt	—
	Clearance between piston and cylinder		0.005~0.015	0.100
	ID of piston pin hole		15.002~15.008	15.040
OD of piston pin		14.994~15.00	14.96	
Clearance between piston and piston pin		0.002~0.014	0.020	
ID of connecting rod small-end		15	15.06	

TROUBLE DIAGNOSIS

Low Or Unstable Compression Pressure

- Cylinder or piston ring worn out.
- Compress pressure to high.
- Too much carbon deposited in combustion chamber and piston.

Knock or Noise

- Cylinder or piston ring worn out.
- Carbon deposits on cylinder head top-side.

- Piston pin hole and piston pin wear out.

Smoking in Exhaust Pipe

- Piston or piston ring worn out.
- Piston ring installation improperly.
- Cylinder or piston damage.5

Engine Overheat

- Carbon deposits on cylinder head top side.

CYLINDER REMOVAL

Remove cylinder head. (refer to chapter 6)
Remove 2 bolts and then take out the cam chain auto-adjuster.

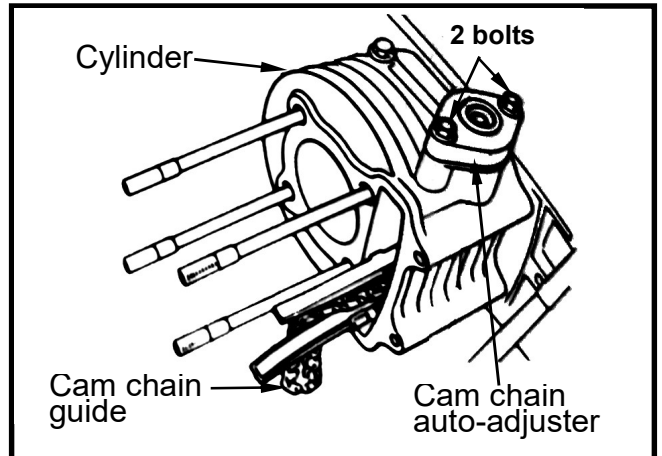

Remove cam chain plate.
Remove cylinder.

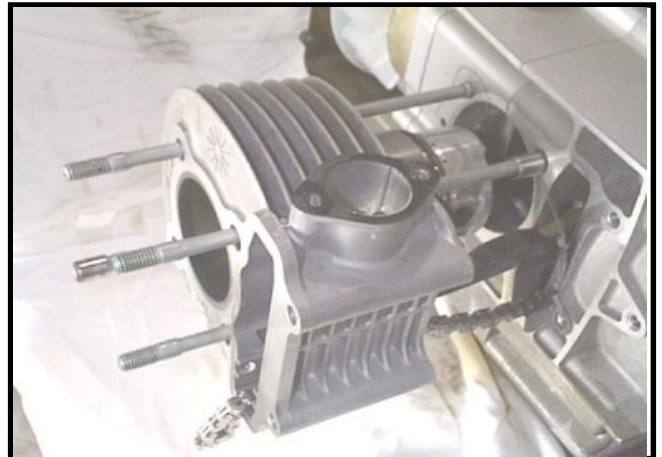

Remove cylinder gasket and lock pins

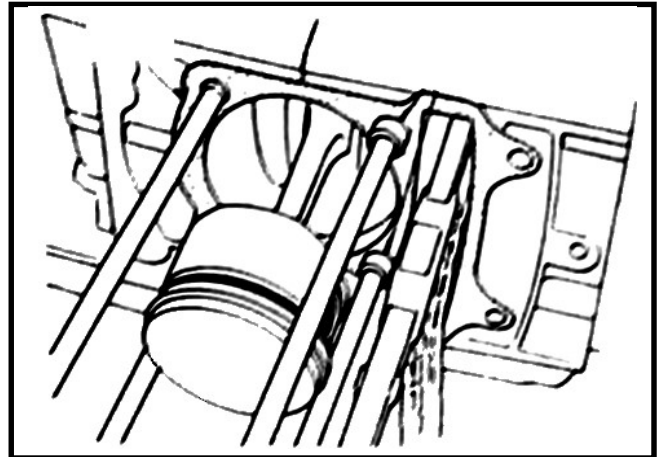

Clean the residues attached onto the matching surfaces of cylinder and crankcase.

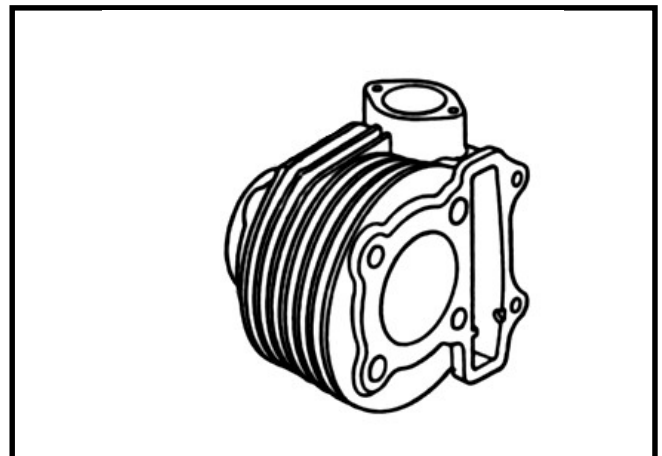

Cover the holes of crankcase and cam chain with a piece of cleaning cloth.
 Clean up all residues or foreign materials from the two matching surfaces of cylinder and crankcase.

⚠ Caution

To soap the residues into solvent so that the residues can be removed more easily.

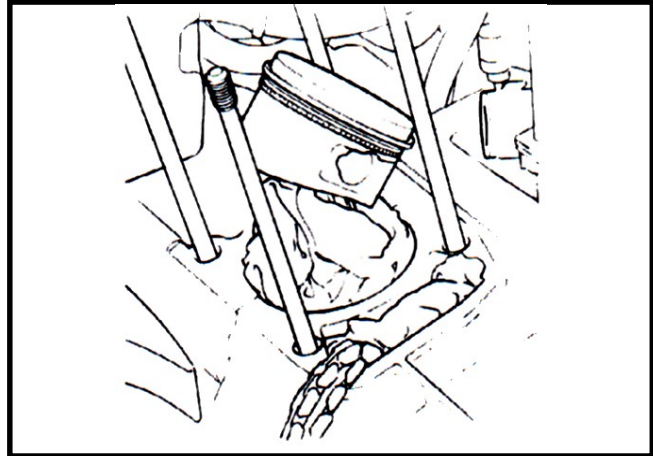

INSPECTION

Check if the inner diameter of cylinder is worn out or damaged.
 In the 3 positions (top, center and bottom) of cylinder, measure the X and Y direction values respective in the cylinder.

Service limit: 57.7mm

Calculate both the real roundness (the difference between X and Y motion values) and the cylindrical roundness (the difference in the top, center or bottom positions of X or Y motion values.). Then, determinate by the max. value.

Service limit

Real roundness: correct or replace as over 0.05 mm

Cylindrical roundness: correct or replace as over 0.05 mm

Check Cylinder flat.

Service limit: correct or replace as over 0.05 mm

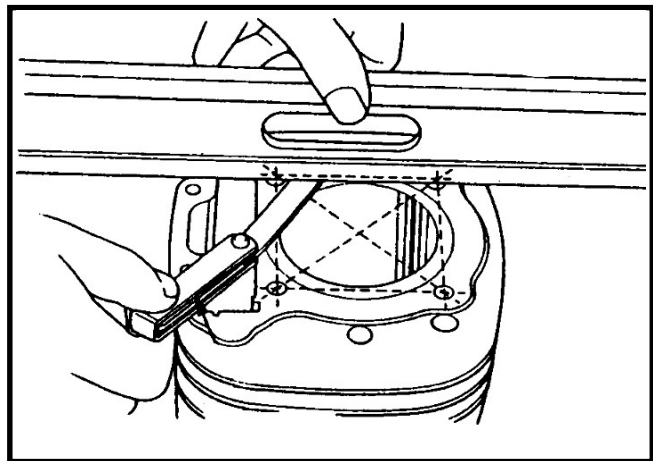
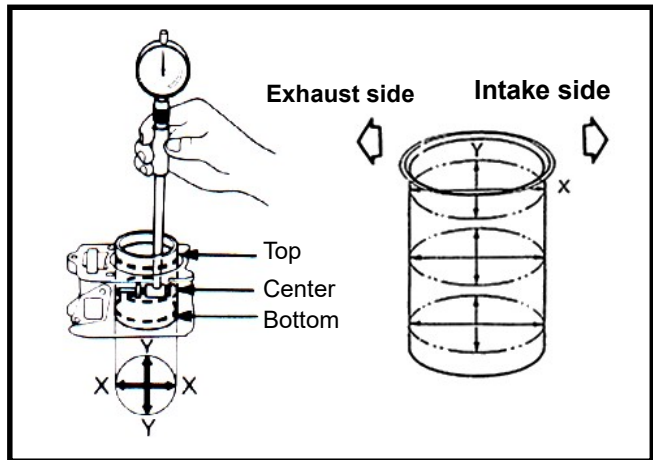

PISTON REMOVAL

Plug crankcase opening with a cleaning cloth to prevent from piston pin snap ring or other parts falling into crankcase when disassembling.

Hold another snap ring with pliers.

Push out the piston pin from the side that not removed the snap ring.

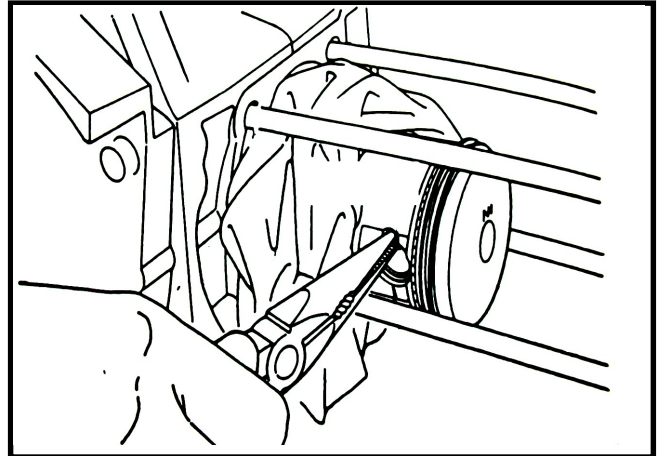

Remove piston rings.

⚠ Caution

Pay attention to remove piston rings because they are fragile.

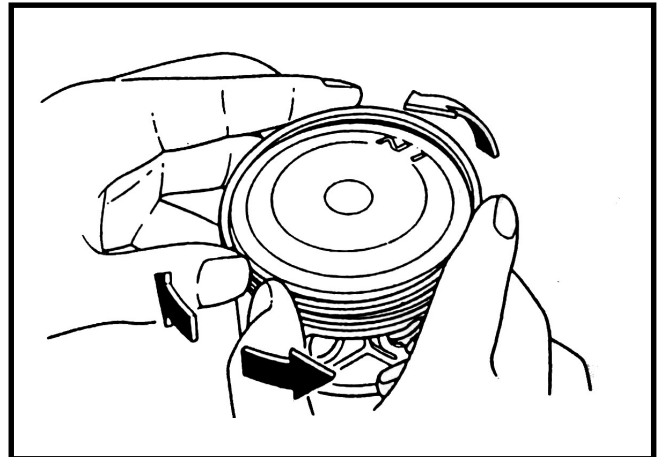

Disassemble the piston rings.
Check if the piston rings are damaged or its grooves are worn.
Cleaning the carbon in piston ring grooves.

Install the piston rings and then measure clearance between piston ring and its grooves.

Service Limit: Top ring: replace if over 0.145mm
2nd ring: replace if over 0.145mm

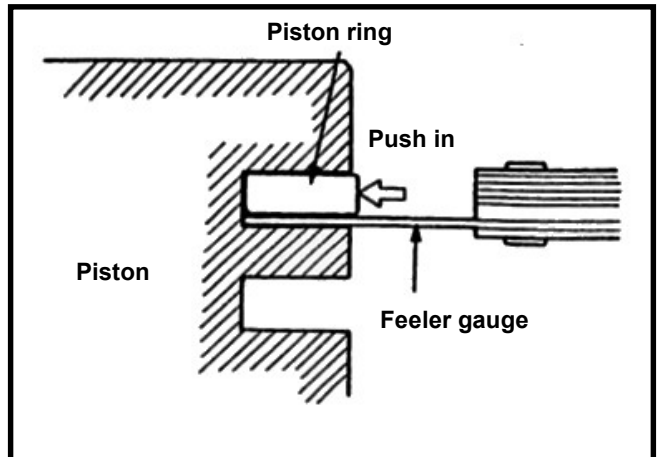

Take out the piston rings and place them respective into cylinder below 20mm of cylinder top. Measure each piston ring gaps.

⚠ Caution

Push the piston rings into cylinder with piston top-end in parallel motion.

Service Limit: Top ring: replace if over 0.50mm
2nd ring: replace if over 0.750mm

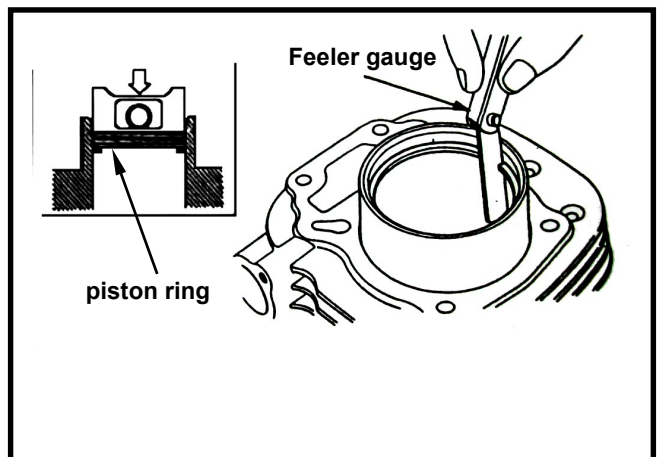

Measure the outer diameter of piston pin.
Service Limit: 14.96mm

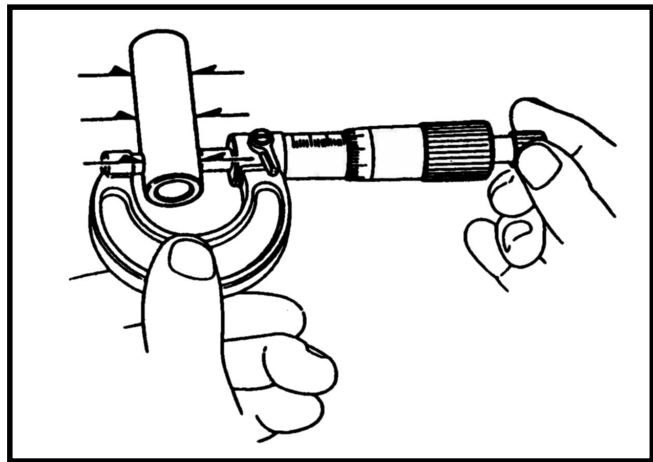

Measure the inner diameter of connecting rod small end.
Service Limit: 15.06mm

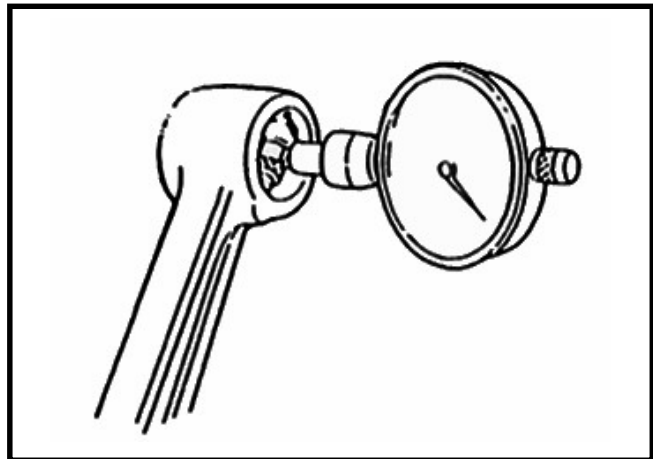

Measure the inner diameter of piston pin hole.
Service Limit: 15.04mm

Calculate clearance between piston pin and its hole.
Service Limit: 0.02mm

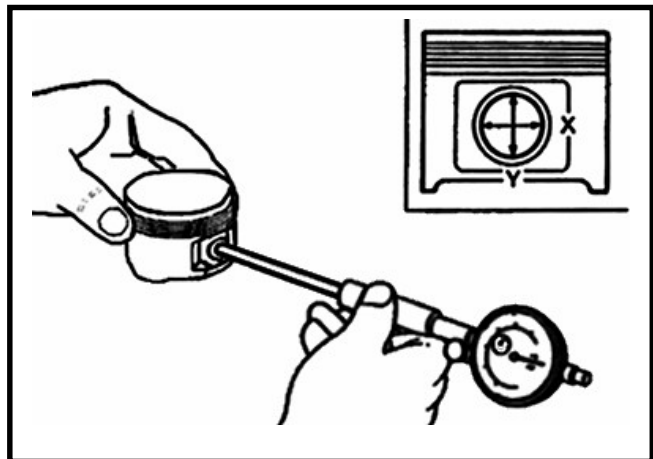

Measure piston outer diameter.

⚠ Caution

The measurement position is 10 mm distance from piston bottom side, and 90° to piston pin.

Service limit: 52.310mm

Compare measured value with service limit to calculate the clearance between piston and cylinder.

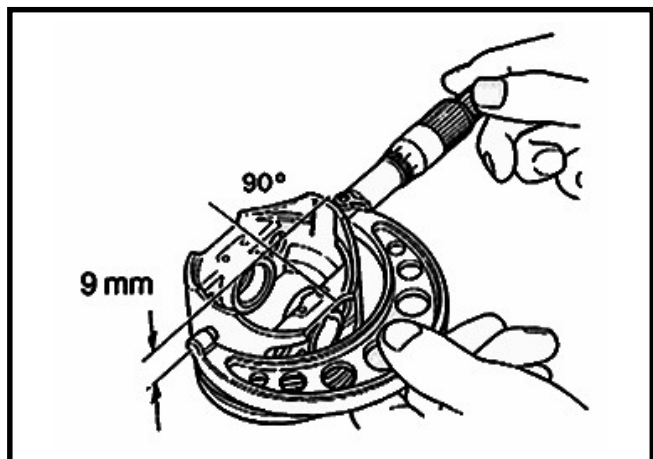

PISTON RING INSTALLATION

Clean up piston top, ring groove, and piston skirt.
 Install the piston ring onto piston carefully.
 Place the openings of piston ring as diagram shown.

⚠ Caution

- Do not damage piston and piston rings as installation.
- All marks on the piston rings must be forwarded to up side.
- Make sure that all piston rings can be rotated freely after installed.

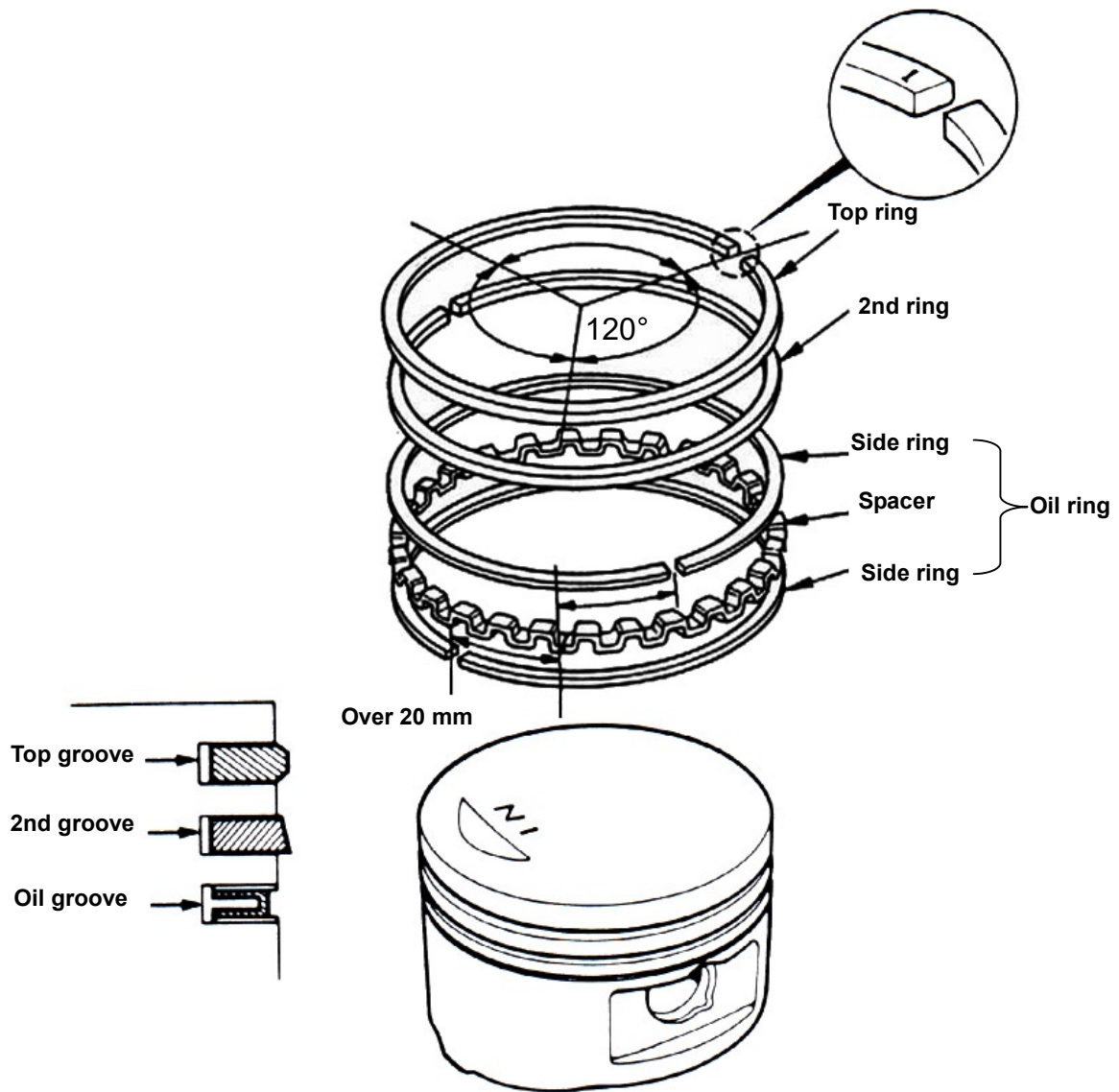

PISTON INSTALLATION

Install piston and piston pin, and place the IN mark on the piston top side forward to intake valve.

Install new piston pin snap ring.

⚠ Caution

- Do not let the opening of piston pin snap ring align with the opening piston ring.
- Place a piece of cleaning cloth between piston skirt section and crankcase in order to prevent snap ring from falling into crankcase as operation.

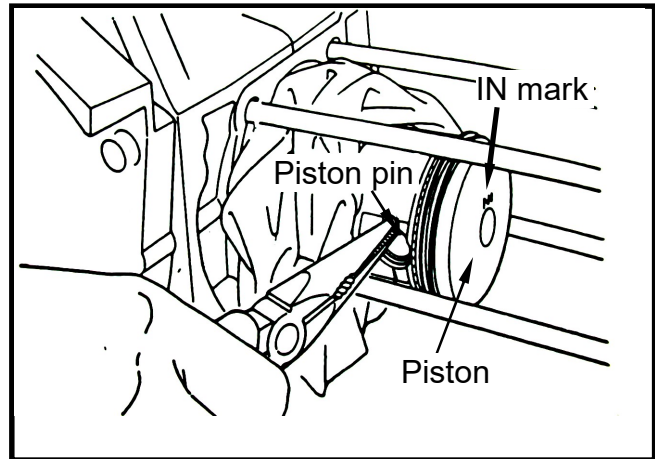

CYLINDER INSTALLATION

Clean up all residues and foreign materials on the matching surface of crankcase.

Pay attention to not let these residues and foreign materials fall into crankcase.

⚠ Caution

To soap the residues into solvent so that the residues can be removed more easily.

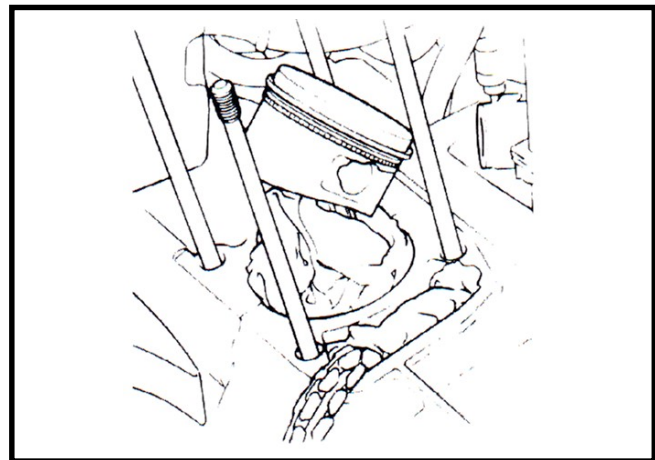

Install 2 lock pins and new gasket.

Coat engine oil to inside of cylinder, piston and piston rings.

Care to be taken when installing piston into cylinder. Press piston rings in one by one as installation.

⚠ Caution

Do not push piston into cylinder forcefully because this will cause the piston and the piston rings to be damaged.

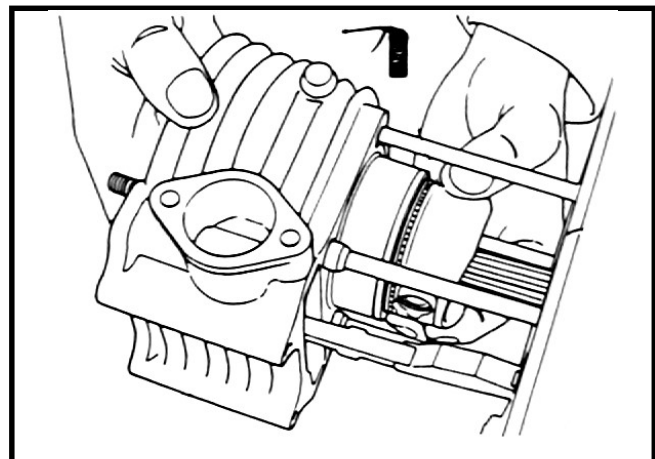

Install the cam chain plate, the cylinder head gasket and lock pins.

Install cylinder head. (refer to Chapter 6)

Install the cam chain auto-adjuster. (2 bolts)

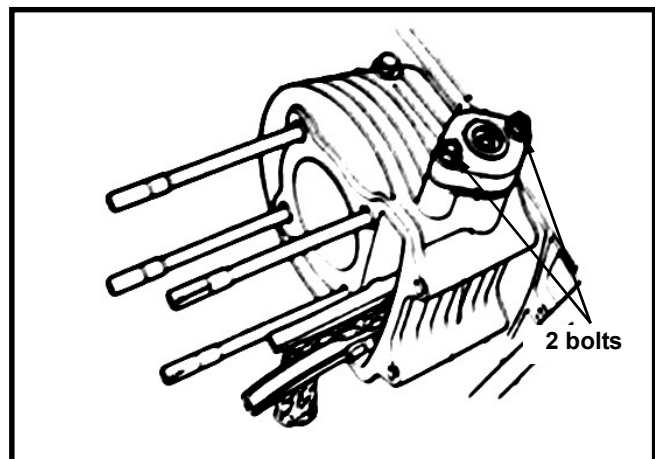

MECHANISM DIAGRAM	8-1	KICK STARTER ARM	8-3
MAINTENANCE DESCRIPTION	8-2	DRIVING BELT	8-4
TROUBLE DIAGNOSIS	8-2	SLIDING PULLEY	8-6
LEFT CRANKCASE COVER	8-3	CLUTCH/DRIVEN PULLEY	8-9

MECHANISM DIAGRAM

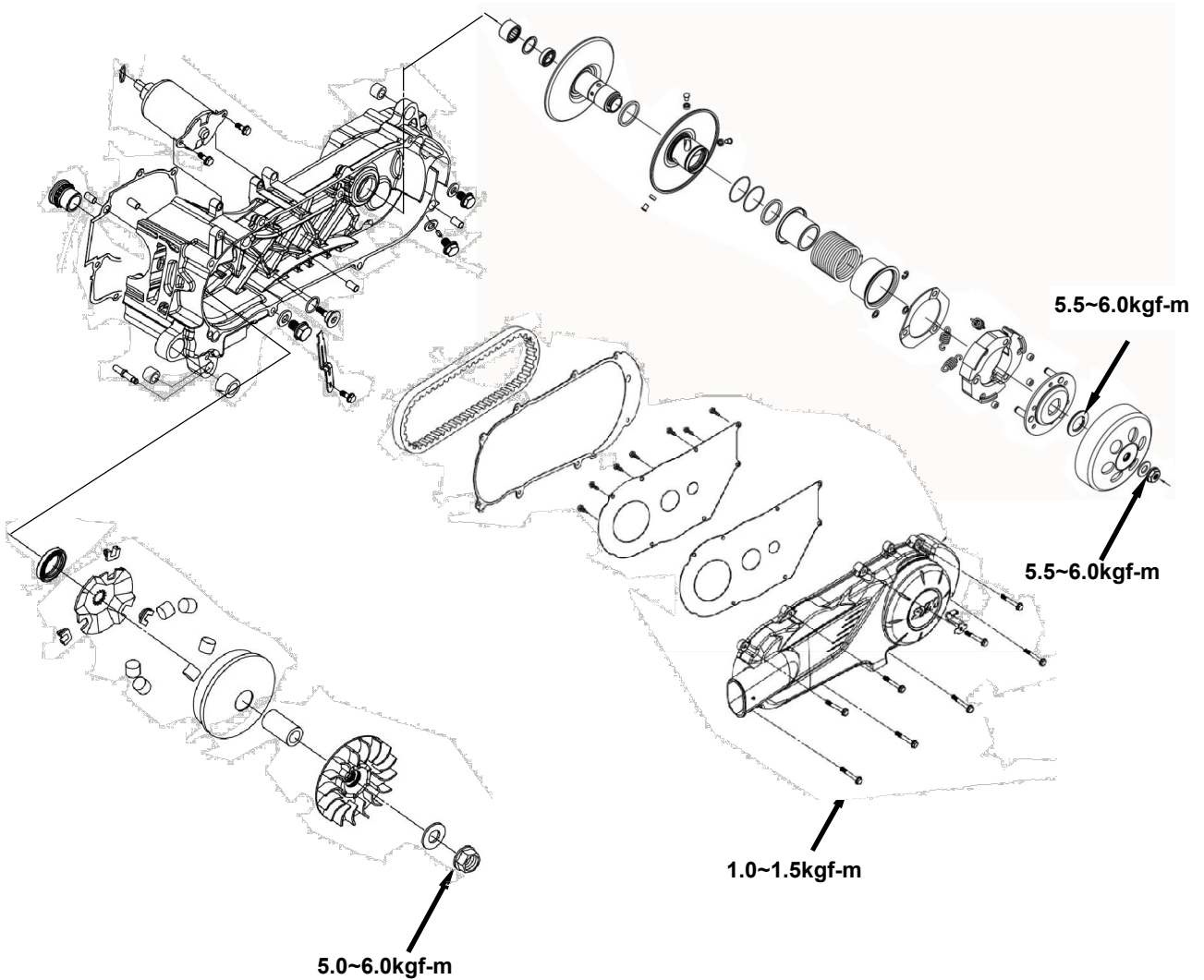

MAINTENANCE DESCRIPTION**Precautions in operation****General information**

- Driving pulley, clutch, and driven pulley can be serviced on the motorcycle.
- Driving belt and driving pulley surface must be free of grease.

Specification

Unit: mm

Item	Standard value	Limit
Driving belt width	19.50	18.50
ID of sliding pulley bush	23.989~24.052	24.060
OD of sliding pulley hub	23.960~23.974	23.940
OD of roller	15.92~16.08	15.400
ID of clutch outer	125.000~125.200	125.500
Thickness of clutch lining	3.000	2.500
Free length of driving pulley spring	168.900	163.700
OD of driven pulley	33.965~33.985	33.940
ID of sliding pulley	34.000~34.025	34.060

ID: Inner Diameter

OD: Outer diameter

Torque value

Sliding pulley nut: 5.0~6.0kgf-m

Clutch outer nut: 5.5~6.0kgf-m

driving pulley nut: 5.5~6.0kgf-m

Special Service Tools

Clutch spring compressor

Bearing puller (inner type)

Clutch mounting nut wrench

Universal fixture

TROUBLE DIAGNOSIS**Engine can be started but motorcycle can not be moved**

- Worn driving Belt
- Worn tilt plate
- Worn or damaged clutch lining
- Broken driven pulley

Shudder or misfire when driving

- Broken clutch lining
- Worn clutch lining

Insufficient horsepower or poor high speed performance

- Worn driving belt
- Insufficient spring capacity of driven pulley
- Worn roller
- Driven pulley operation un-smoothly

LEFT CRANKCASE COVER**Left crankcase cover removal**

Remove air cleaner. (2 bolts)

Loosen vent strap on the front-left side of cover, and then remove the vent.

Remove engine left-side cover (8 bolts).

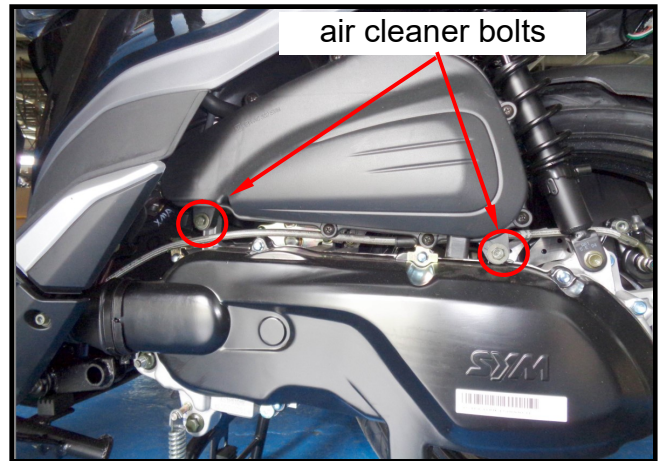
**Installation of the left crankcase cover**

Install the left crankcase cover. (8 bolts)

Install front vent tube of left cover and tighten the strap.

Tighten the air cleaner. (2 bolts)

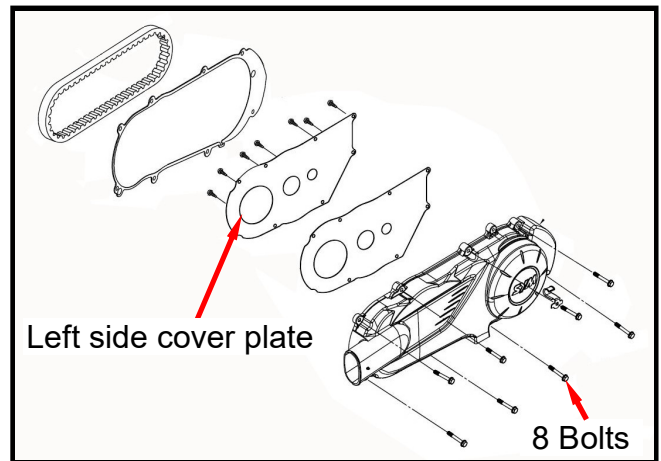

DRIVING BELT

Removal

Remove left crankcase cover.
Hold the driving pulley with a universal fixture,
and then remove the nut and driving pulley.

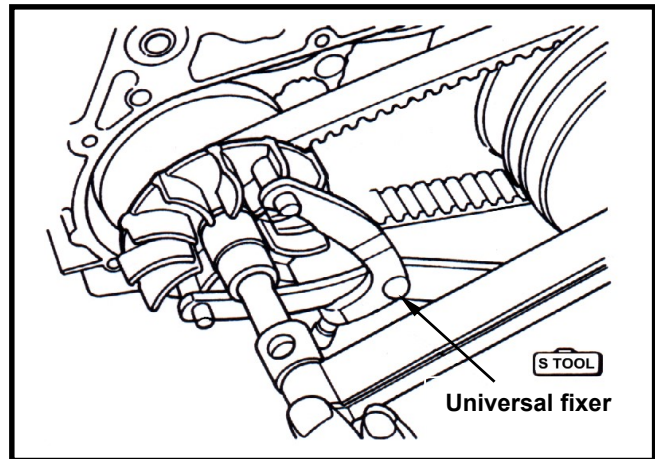

Hold driving pulley with universal fixture, and
remove nut and clutch outer.

⚠ Caution

Using special service tools for tightening or
loosening the nut. Fixed rear wheel or rear
brake only will damage reduction gear
system.

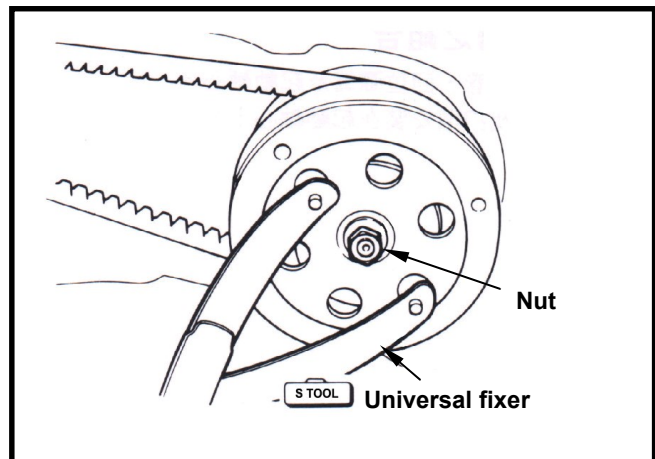

Push the driving belt into belt groove as
diagram shown so that the belt can be
loosened, and then remove driven belt and
clutch at same time.

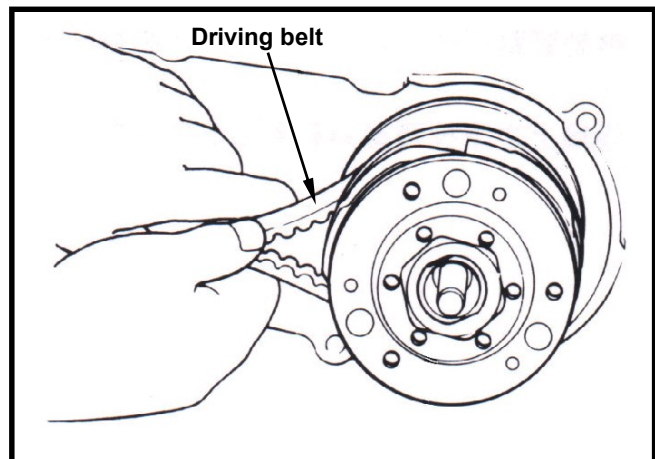

Inspection

Check the driving belt for crack or wear.
Replace it if necessary.
Measure the width of driving belt as diagram
shown. Replace the driving belt if it exceed
maintenance limited specification.

Service Limit: 18.5mm

⚠ Caution

- Using the genuine parts for replacement.
- The surfaces of driving belt or pulley must be free of grease.
- Clean up all grease or dirt before installation.

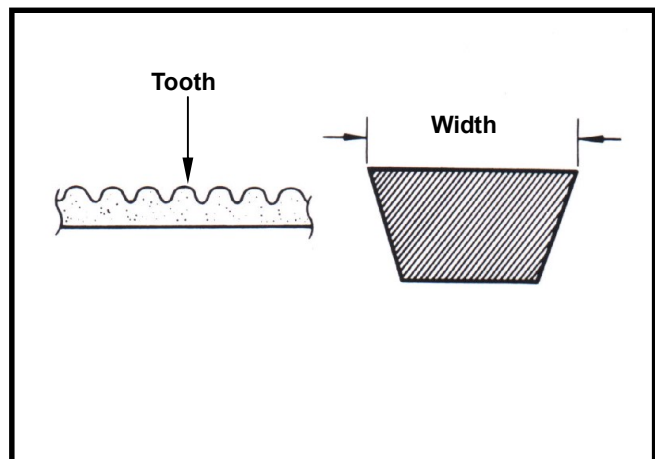

Installation

Pull out the driving pulley and then insert the driving belt into the driving pulley.

⚠ Caution

Pull out driving pulley and then insert the driving belt into the driving pulley so that the driving belt set can be installed onto sliding pulley more easily.

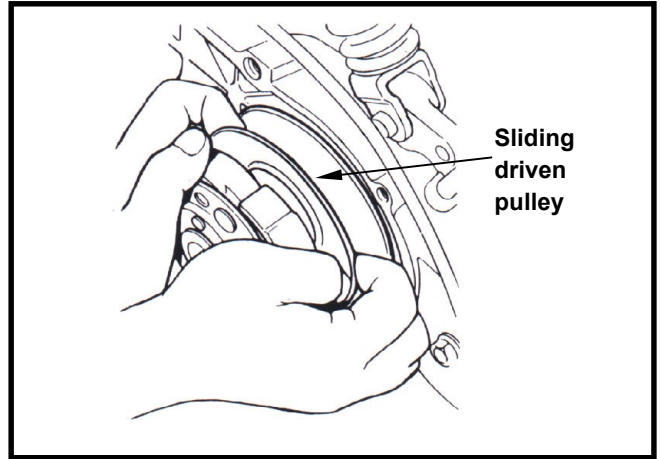

Install the clutch set with driving belt onto the driving shaft.
 Install the sliding pulley on the other end of belt.
 Install clutch outer.

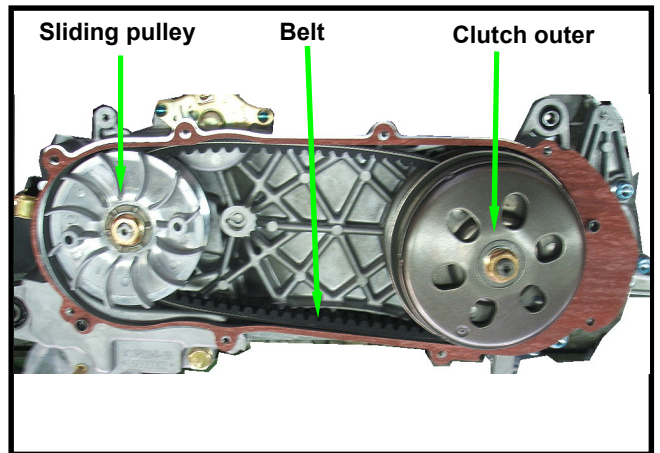

Install the clutch with universal fixture, and then tighten nut to specified torque value.
Torque value: 5.5~6.0 kgf-m

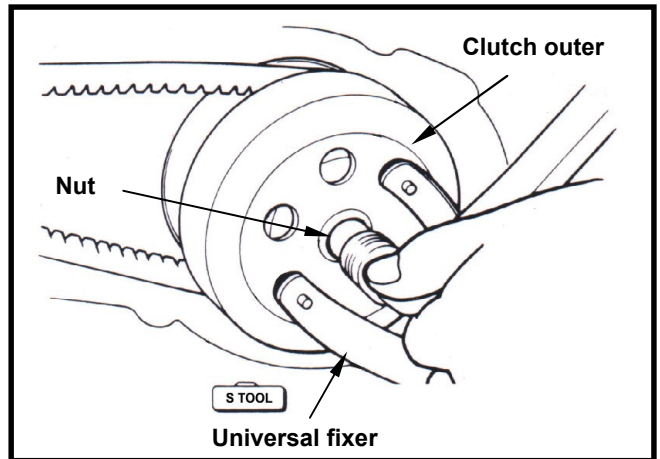

⚠ Caution

When install the driving belt, if there is a arrow mark, then the arrow mark must point to rotation motion. If not, the letters on the belt must be forwarded to assembly direction.

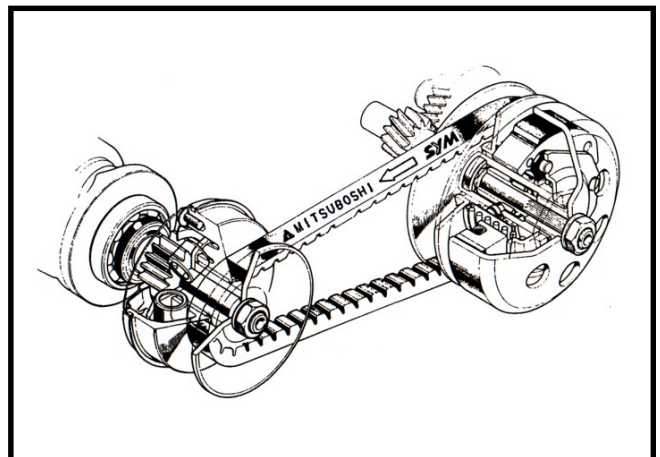

**SLIDING PULLEY
REMOVAL**

Remove left crankcase cover.
Hold driving pulley with universal fixture, and then remove driving pulley nut.
Remove driving pulley.

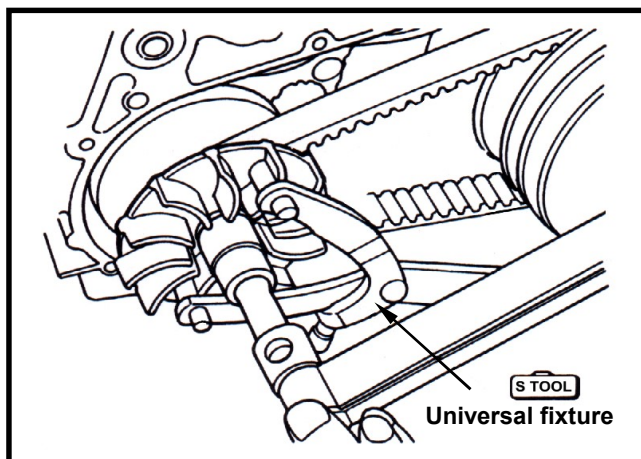

Remove the driving belt from the pulley.
Remove sliding pulley set and driving pulley hub from crankshaft.

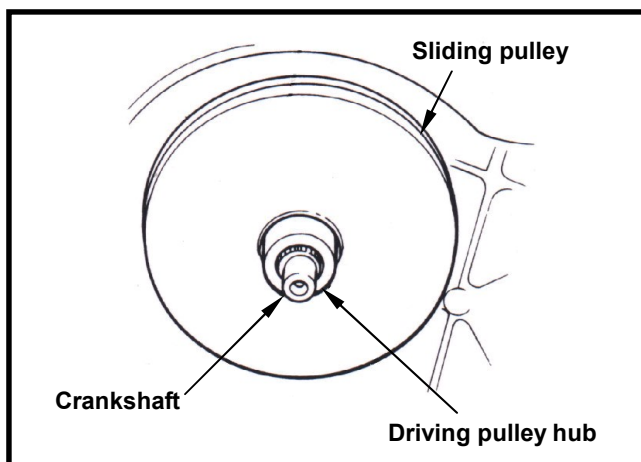

Remove tilt plate.

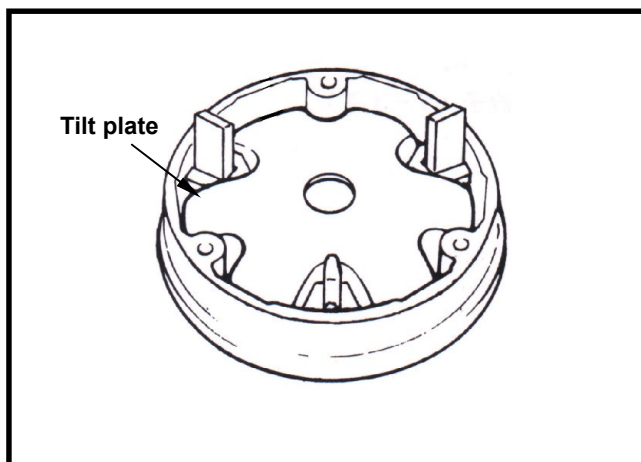

Remove weight rollers from sliding pulley.

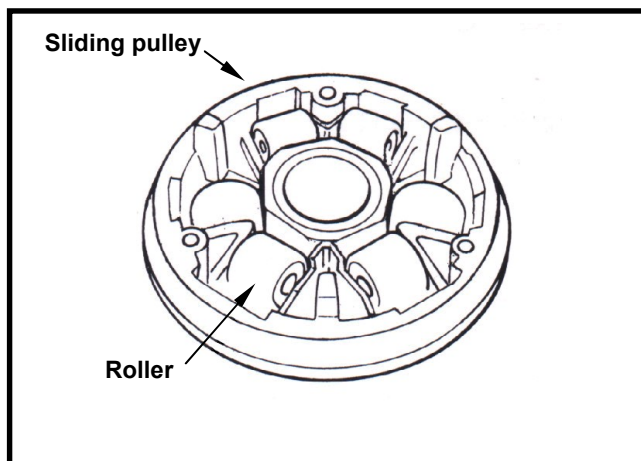

Inspection

The operation of sliding pulley is means of the weight roller to pressing on it with centrifuge force. And then the speed is changed by the title plate rotation. Thus, if weight rollers are wear out or damage, the centrifuge force will be effected.

Check if rollers are wear out or damage.

Replace it if necessary.

Measure each rollers' outer diameter.

Replace it if exceed the service limit.

Service limit: 15.40 mm

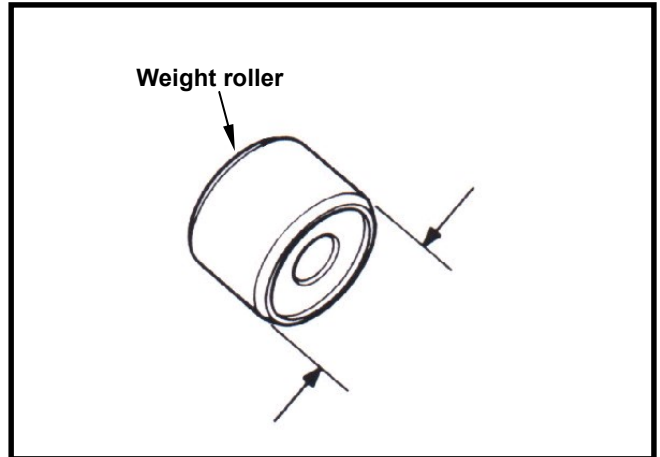

Check the pulley hub if damaged or wear out.

Replace it if necessary.

Measure the pulley hub's outer diameter.

Replace it if exceed the service limit.

Service limit: 23.94 mm

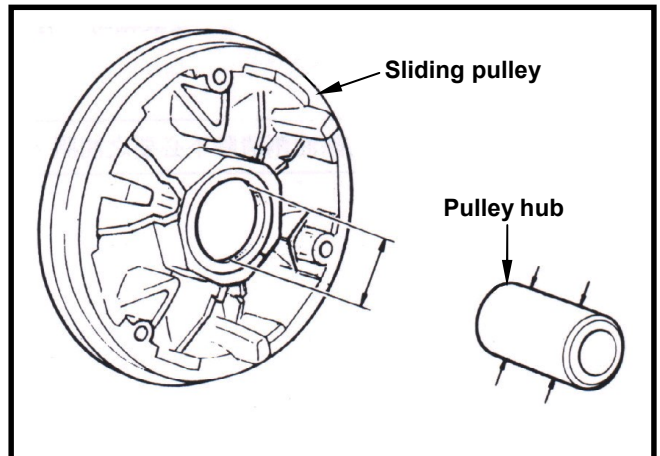

Measure the inner diameter of the pulley bush.

Replace it if exceed the service limit.

Service limit: 24.06 mm

Assembly/Installation

Install the weight rollers.

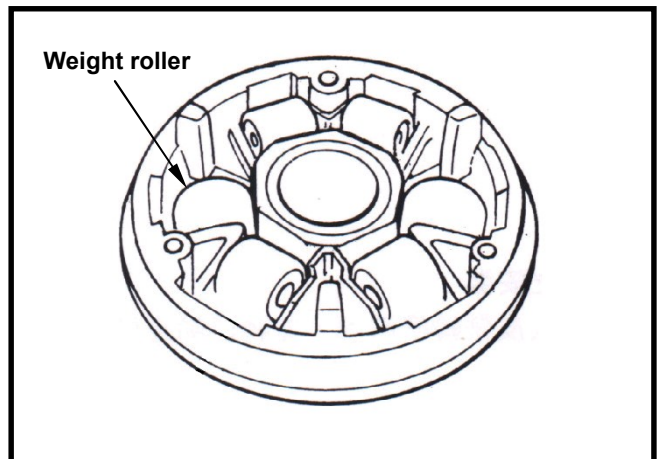

Install the title plate guide boot onto the title plate.

Install the title plate.

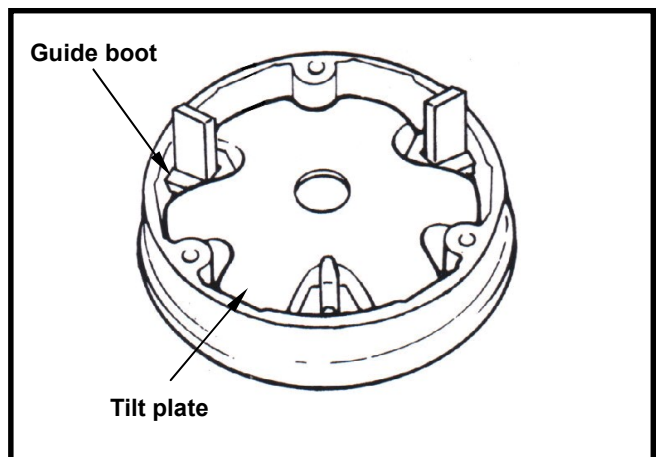

Apply with grease 4~5 g to inside of driving shaft hole, and install driving pulley hub.

⚠ Caution

The pulley surface has to be free of grease. Clean it with cleaning solvent.

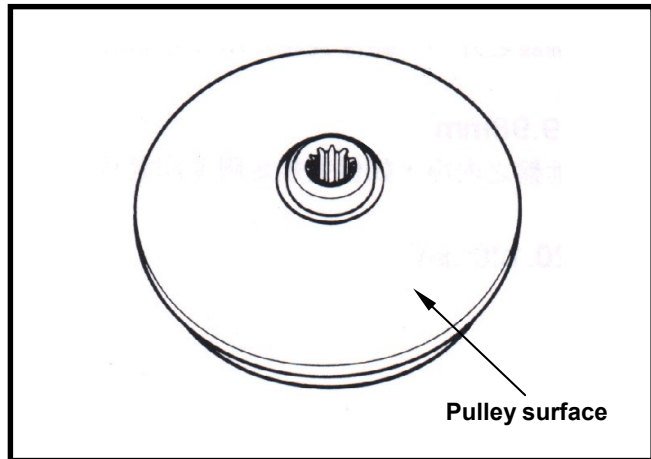

Install sliding pulley assembly onto crankshaft.

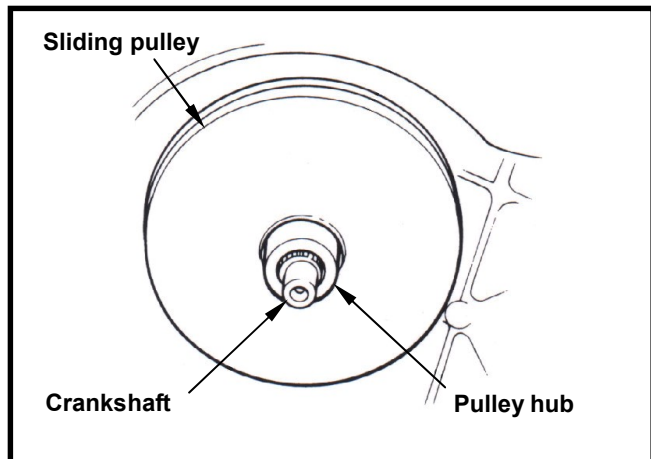

Driving pulley install

Press driving belt into pulley groove, and then press down the up & down sides of the driving belt to separate it away from the driving pulley hub.

⚠ Caution

To press down the up & down sides of the driving belt can avoid to pressing and damaging the belt when installing the driving pulley, and also can make sure that the driving pulley can be tighten.

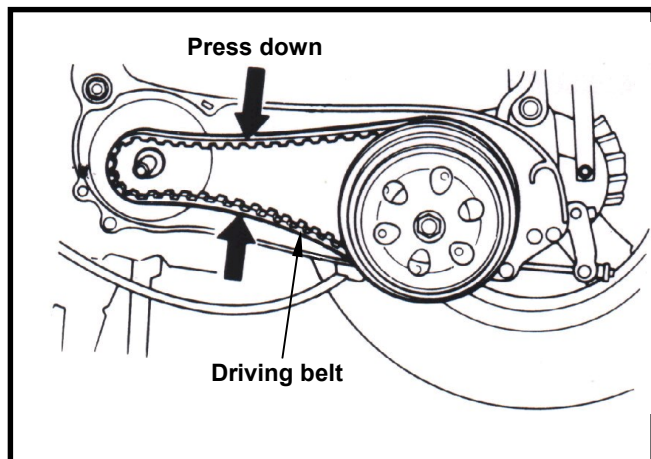

Install driving pulley, washer and nut.

⚠ Caution

Make sure that two sides of pulley surfaces have to be free of grease. Clean it with cleaning solvent.

Hold driving pulley with universal fixture. Tighten nut to specified torque.

Torque value: 5.0~6.0 kgf-m

Install left crankcase cover.

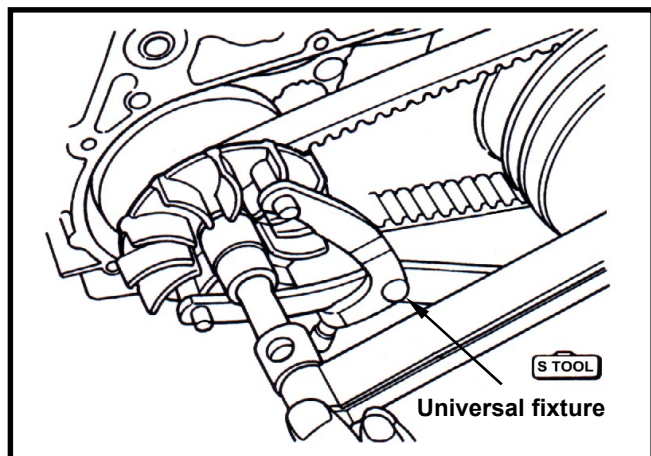

CLUTCH/DRIVEN PULLEY**Disassembly**

Remove driving belt and clutch/driven pulley. Install clutch spring compressor onto the pulley assembly, and operate the compressor to let nut be installed more easily.

⚠ Caution

Do not press the compressor too much.

Hold the clutch spring compressor onto bench vise, and then remove mounting nut with special nut wrench. Release the clutch spring compressor and remove clutch and spring from driven pulley. Remove socket from driven pulley.

Remove oil seal from driven pulley. Remove guide pin, guide pin roller, and sliding pulley, and then remove O-ring & oil seal seat from sliding pulley.

Inspection**Clutch outer**

Measure the inner diameter of clutch outer friction face. Replace the clutch outer if exceed service limit.

Service limit: 125.5 mm

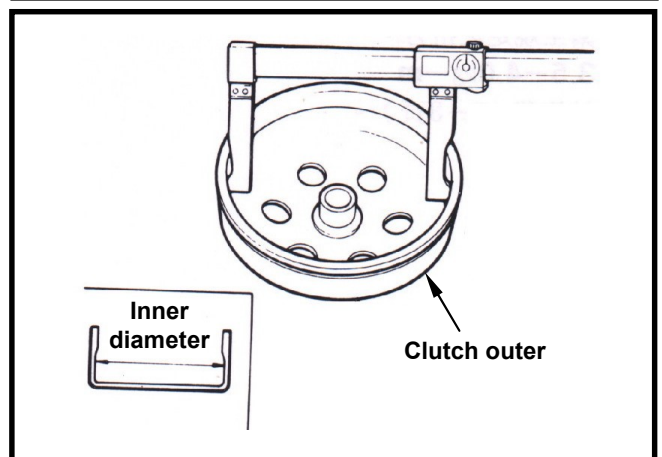
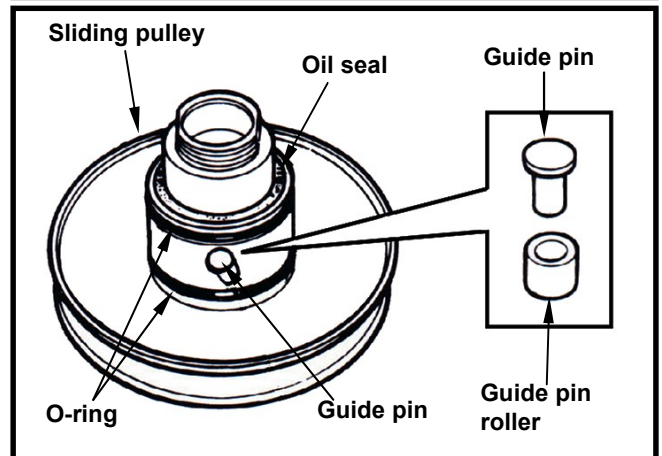
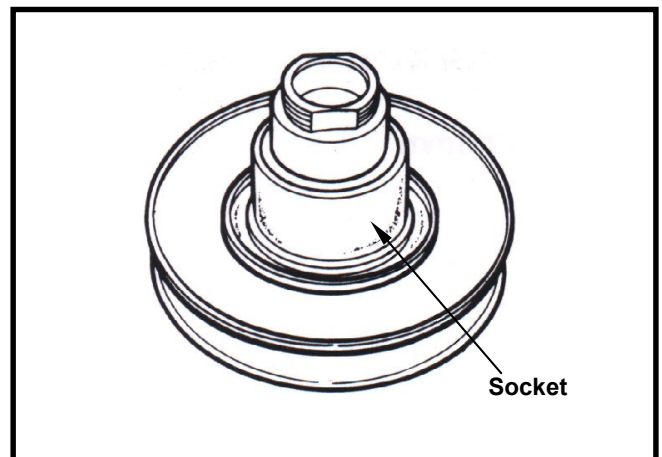
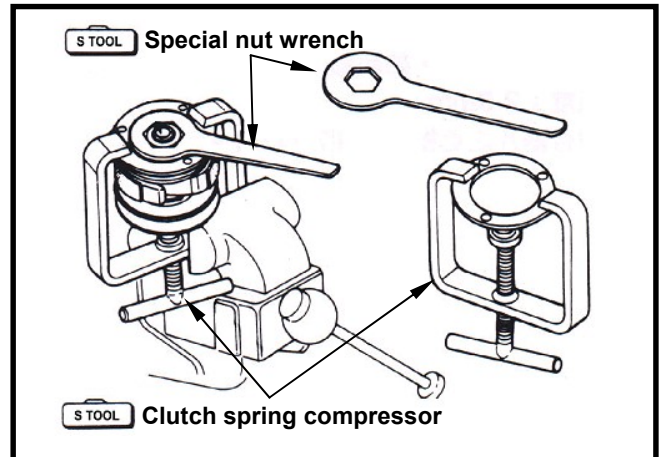

Clutch lining

Measure each clutch lining thickness.
Replace it if exceeds service limit.

Service limit: 2.5mm

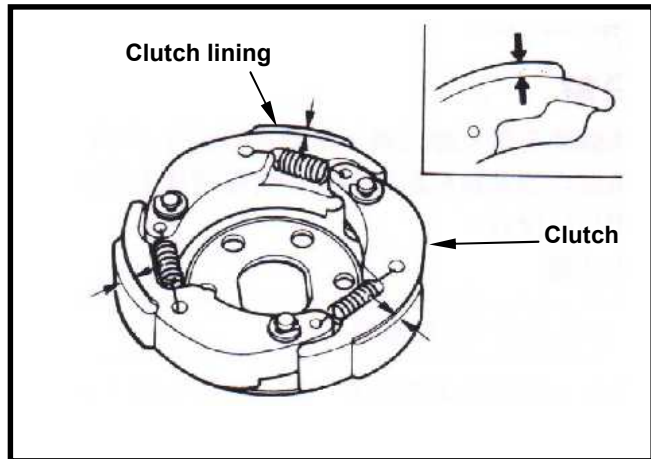

Driven pulley spring

Measure the length of driven pulley spring.
Replace it if exceeds service limit.

Service limit: 163.7mm

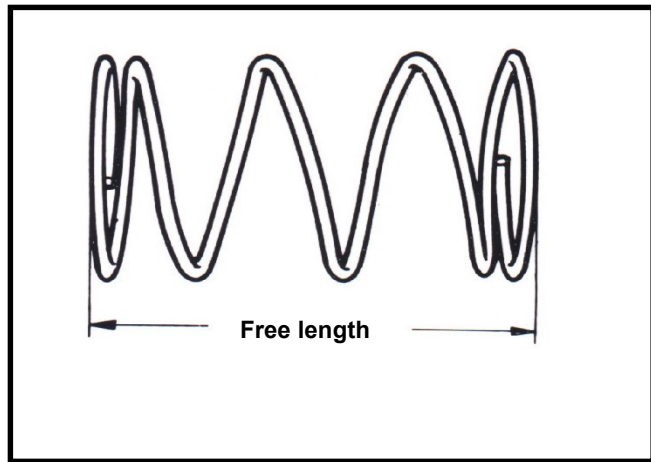

Driven pulley

Check following items;

- If both surfaces are damage or wear.
- If guide pin groove is damage or wear.

Replace damaged or worn components.
Measure the outer diameter of driven face and the inner diameter of movable driven face. Replace it if exceeds service limit.

**Service limit: Outer diameter 33.94mm
Inner diameter 34.06mm**

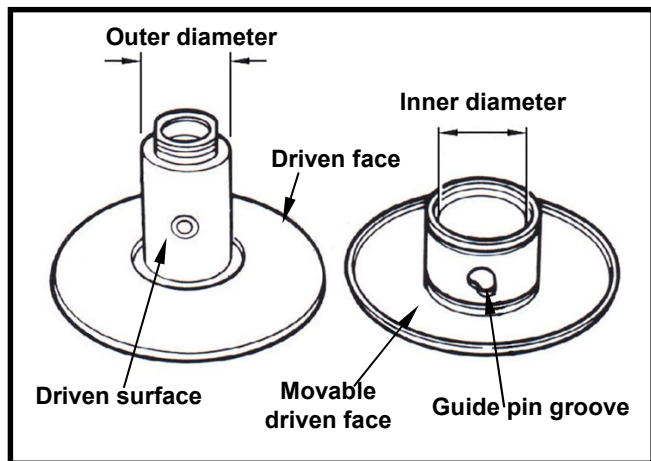

Driven Pulley Bearing Inspection

Check if the inner bearing oil seal is damage.
Replace it if necessary.

Check if needle bearing is damage or too big clearance.
Replace it if necessary.

Rotate the inside of inner bearing with fingers to check if the bearing rotation is in smooth and silent.

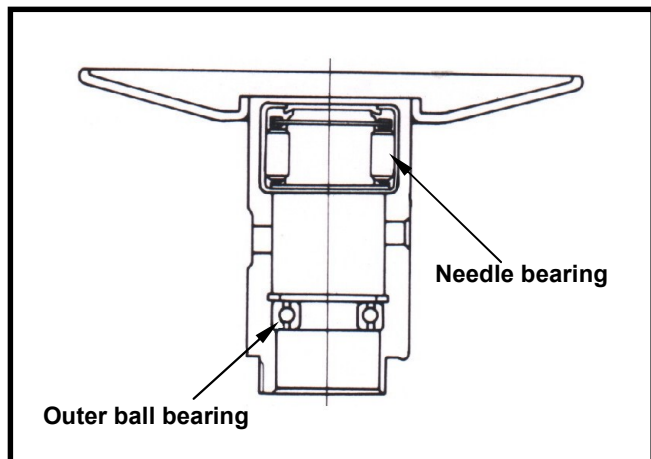

Clutch Block Replacement

Remove snap and washer, and then remove the clutch block and spring from the driving plate. Check if the spring is damaged or has insufficient elasticity.

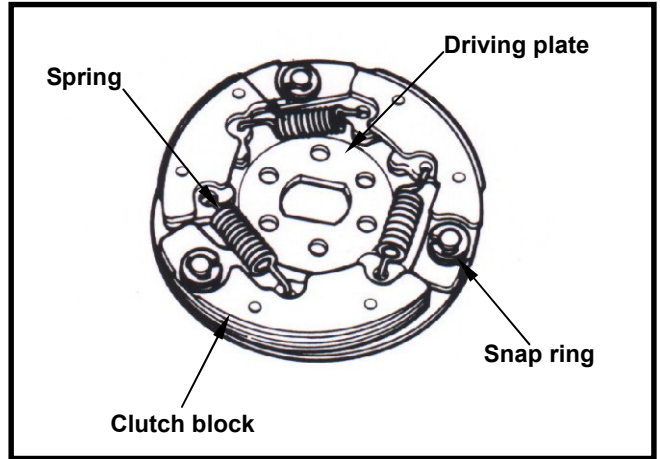

Check if the shock absorption rubber is damaged or deformed. Replace it if necessary. Apply grease to the setting pins.

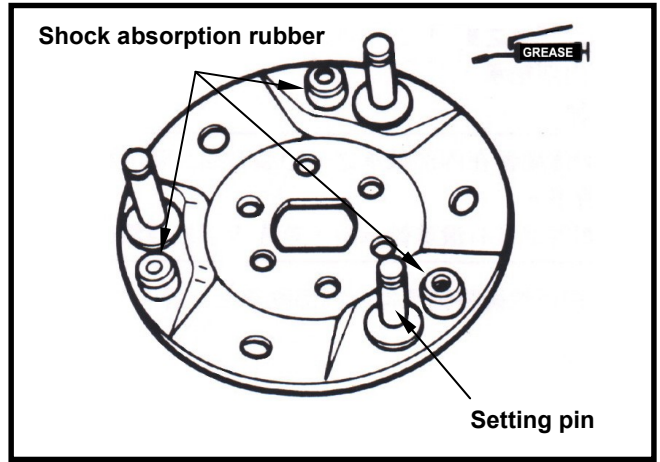

Apply grease to the setting pins. However, the clutch block should not be greased. If so, replace it. Install the new clutch block onto the setting pin and then push it to the specified location.

⚠ Caution

- Grease or lubricant will damage the clutch block and affect the block's connection capacity.

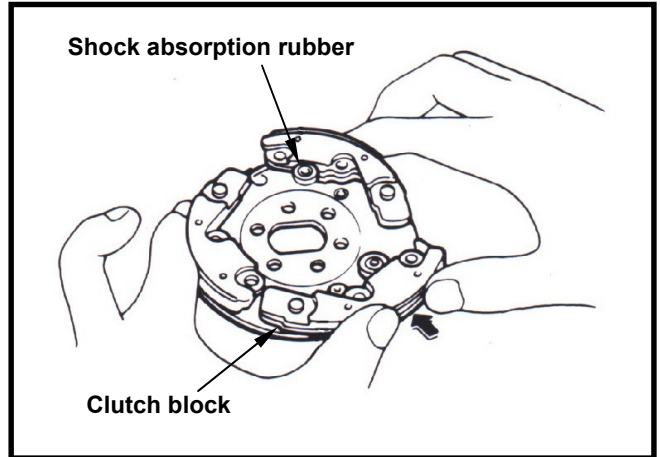

Install the spring snap into the groove with pliers.

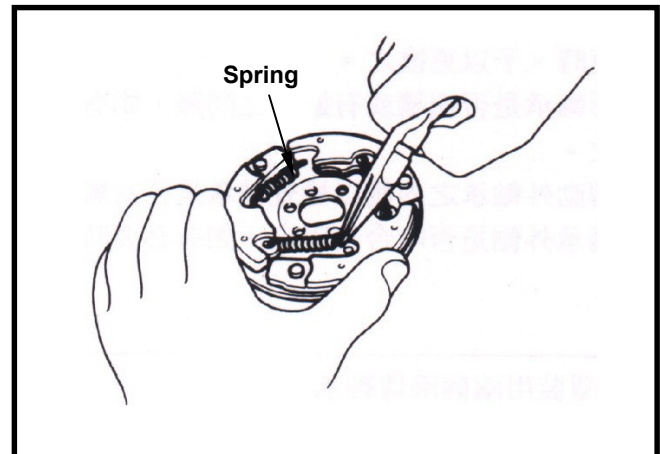

Install snap ring and mounting plate onto setting pin.

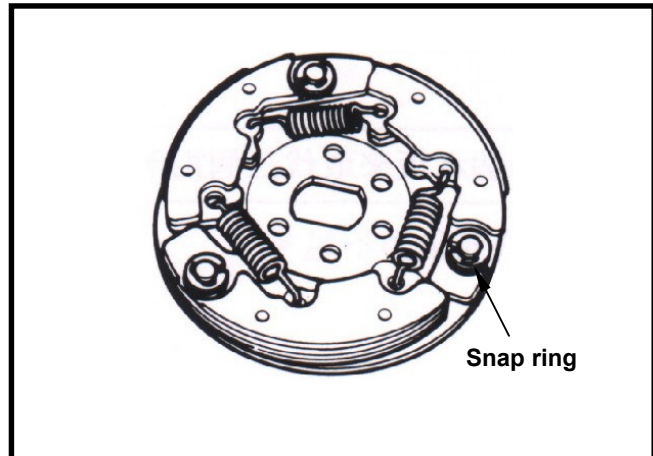

Replacement of driven pulley bearing

Remove inner bearing.

⚠ Caution

- If the inner bearing equipped with oil seal on one side in the driven pulley, then remove the oil seal firstly.
- If the pulley equipped with ball bearing, it has to remove snap ring and then the bearing.

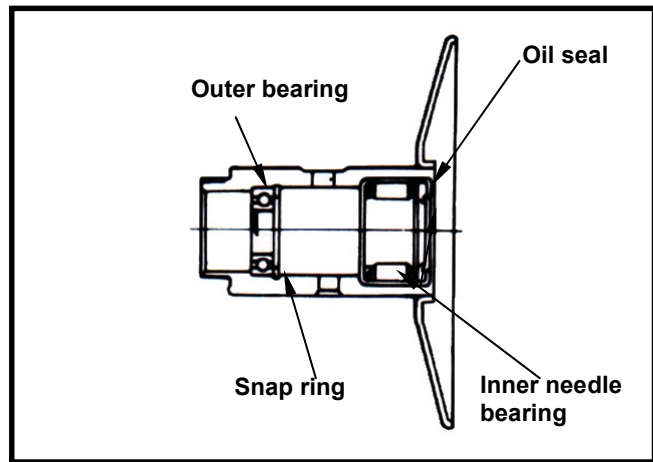

Remove snap ring and then push bearing forward to other side of inner bearing. Place new bearing onto proper position and its sealing end should be forwarded to outside. Apply with specified grease. Recommended to use the KING MATE G-3. Install the snap ring and hold the bearing.

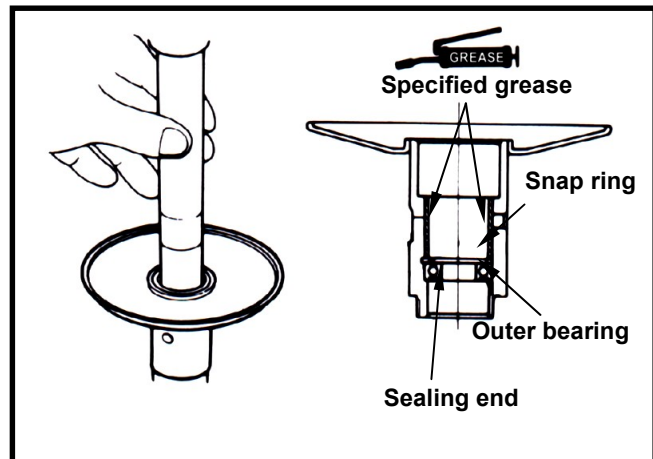

Install a new inner bearing.

⚠ Caution

- Its sealing end should be forwarded to outside as bearing installation.
- Install needle bearing with hydraulic presser. Install ball bearing by means of hydraulic presser.

Align oil seal lip with bearing, and then install the new oil seal (if necessary).

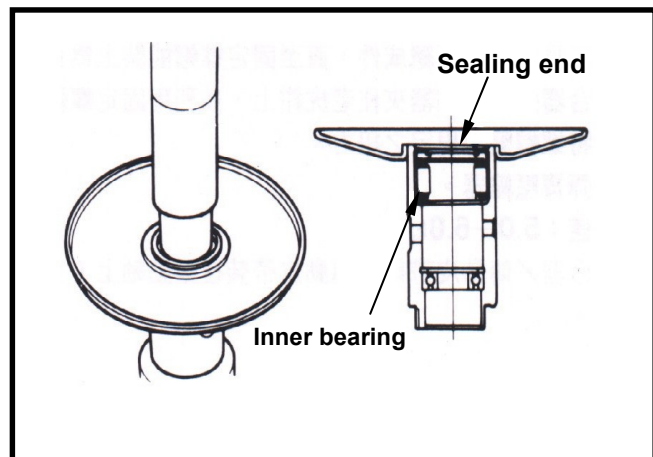

Installation of clutch/driven pulley

Install new oil seal and O-ring onto sliding pulley. Apply with specified grease to lubricate the inside of sliding pulley.

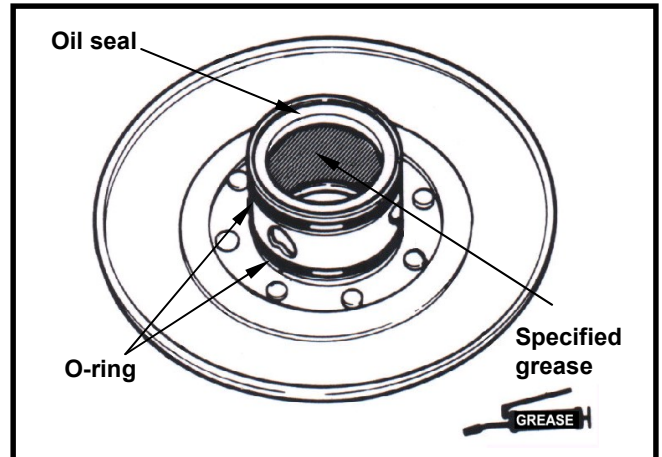

Install sliding pulley onto driven pulley. Install guide pin and guide pin roller.

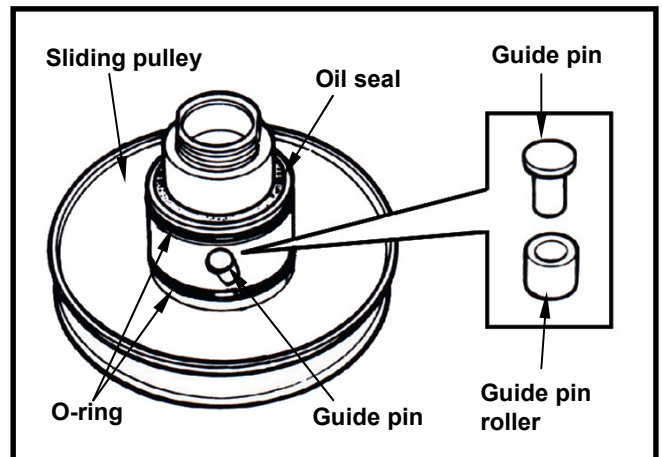

Install oil socket.

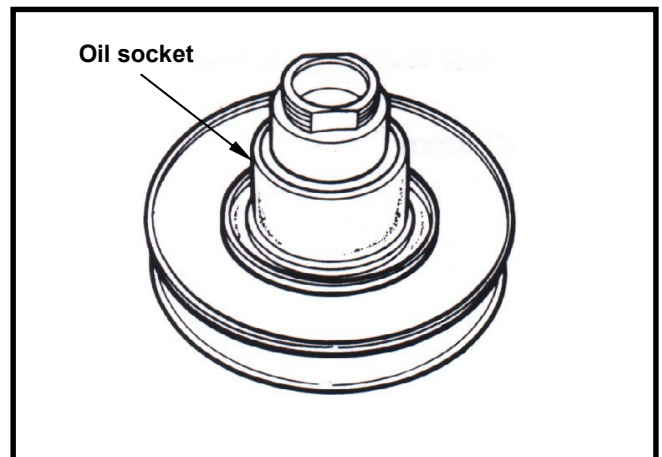

Install driven pulley, spring and clutch into clutch spring compressor, and press down the assembly by turning manual lever until mounting nut that can be installed. Hold the compressor by bench vise and tighten the mounting nut to specified torque with special nut wrench.

Remove the clutch spring compressor.

Torque value: 5.5~6.0 kg-m

Install clutch/driven pulley and driving belt onto driving shaft.

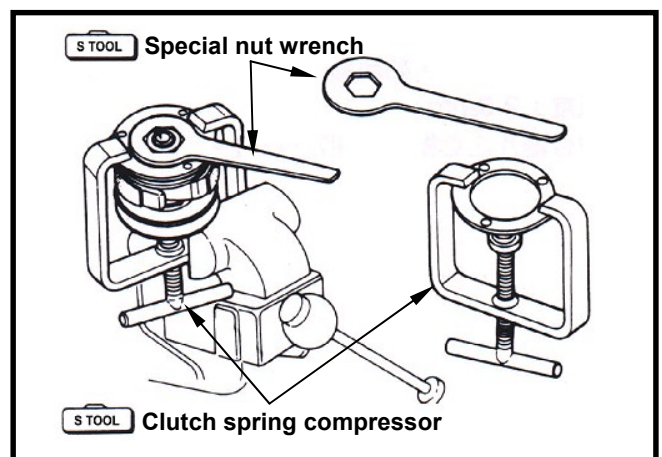

MECHANISM DIAGRAM 9-1	INSPECTION OF FINAL DRIVING MECHANISM 9-3
OPERATIONAL PRECAUTIONS 9-2	BEARING REPLACEMENT 9-4
TROUBLE DIAGNOSIS 9-2	RE-ASSEMBLY OF FINAL DRIVING MECHANISM 9-6
DISASSEMBLY OF FINAL DRIVING MECHANISM 9-3	

MECHANISM DIAGRAM

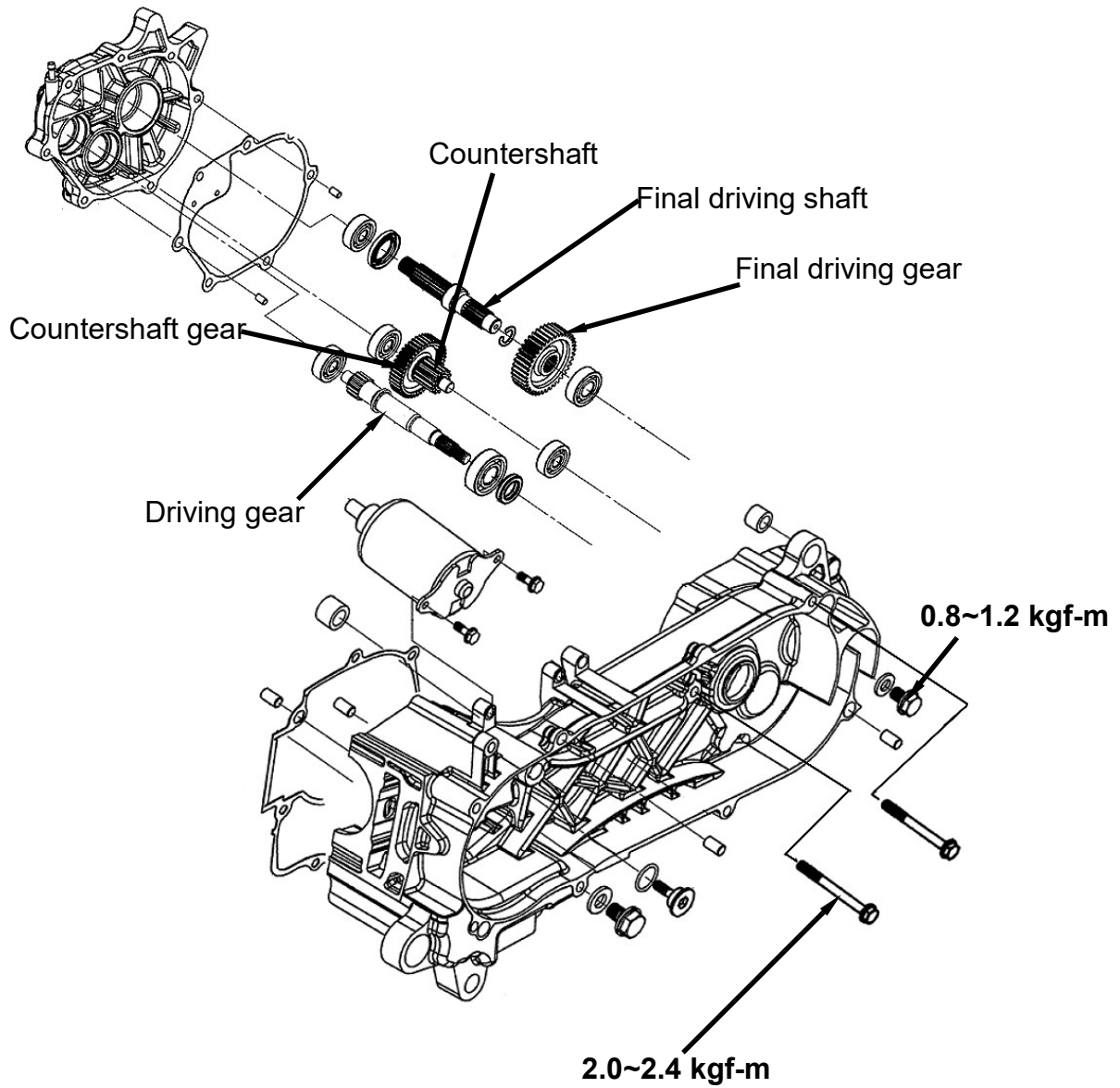

OPERATIONAL PRECAUTIONS

Specification

Application gear oil: 4-stroke lubricant
Recommended gear oil:85W-140
Oil quantity: 180 c.c. (170 c.c. when replacing)

Torque value

Gear box cover	0.8~1.2 kgf-m
Gear oil drain plug	1.0~1.4 kgf-m
Gear oil filling bolt	0.8~1.2 kgf-m

Tools

Special service tools

Inner type bearing puller
Outer type bearing puller
Gear box oil seal installer
Gear box bearing installer

TROUBLE DIAGNOSIS

Engine can be started but motorcycle can not be moved

- Damaged driving gear
- Burnt out driving gear
- Broken driving belt

Gear oil leaks

- Excessive gear oil
- Worn or damage oil seal

Noise

- Worn or burnt gear
- Worn gear

DISASSEMBLY OF FINAL DRIVING MECHANISM

Remove the rear wheel. (refer to chapter 15)
 Remove the clutch.
 Drain gear oil out from gear box.
 Remove gear box cover bolts (7bolts) and then remove the cover and the final driving shaft.
 Remove gasket and setting pin.

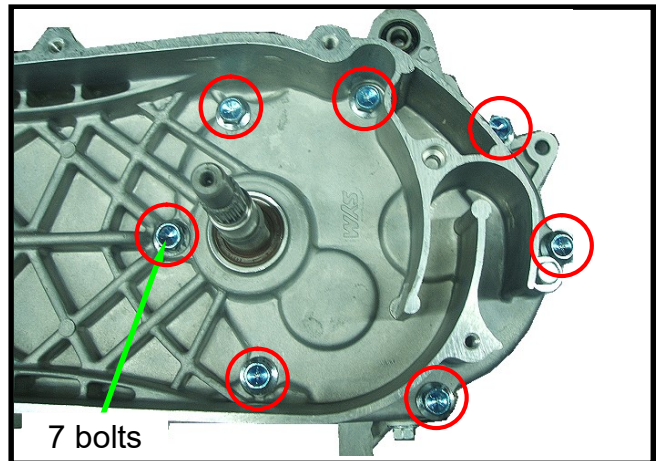

Remove countershaft and gear.
 Remove final driving gear and shaft.

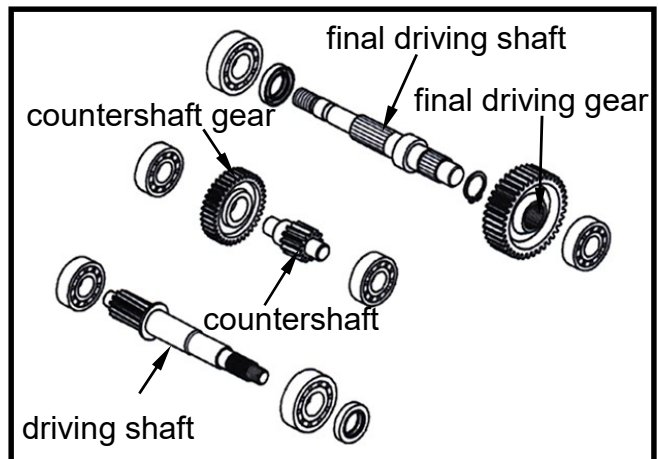

INSPECTION OF FINAL DRIVING MECHANISM

Check if the countershaft and the gear are wear or damage.

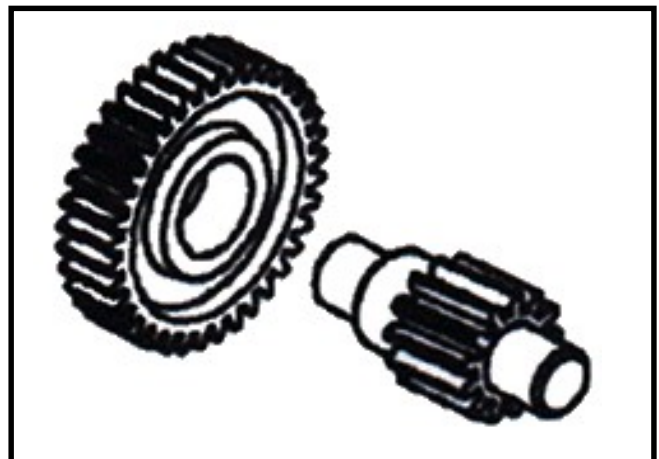

Check if the final driving shaft and gear are burn, wear or damage.

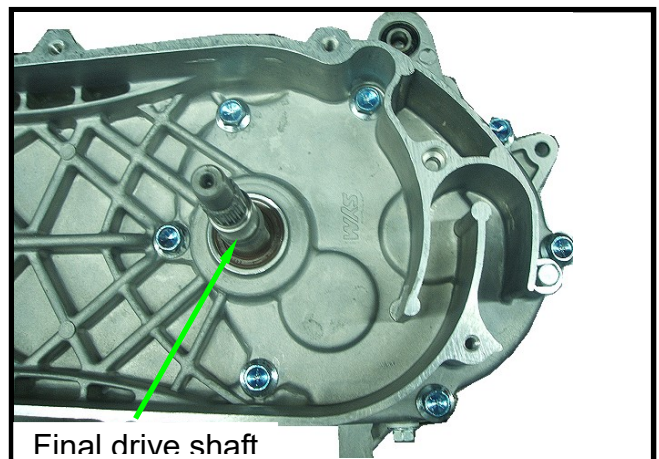

9. FINAL DRIVING MECHANISM

SYM

Check bearings on gear box and cover. Rotate each bearing's inner ring with fingers. Check if bearings can be turned in smooth and silent, and also check if bearing outer ring is mounted on gear box & cover tightly. If bearing rotation is uneven, noising, or loose bearing mounted, then replace it. Check oil seal for wear or damage, and replace it if necessary.

Caution

- Do not remove the driving shaft from the cover top side.
- If remove the driving shaft from the cover top side, then its bearing has to be replaced.

Check driving shaft and gear for wear or damage.

BEARING REPLACEMENT

Caution

Never install used bearings. Once bearing removed, it has to be replaced with new one.

Remove driving shaft bearing from left crankcase using following tools;
Inner type bearing puller

Install new driving shaft bearing into left crankcase.

Tool:

Press the bearing into cover with C type hydraulic presser or bearing installer.

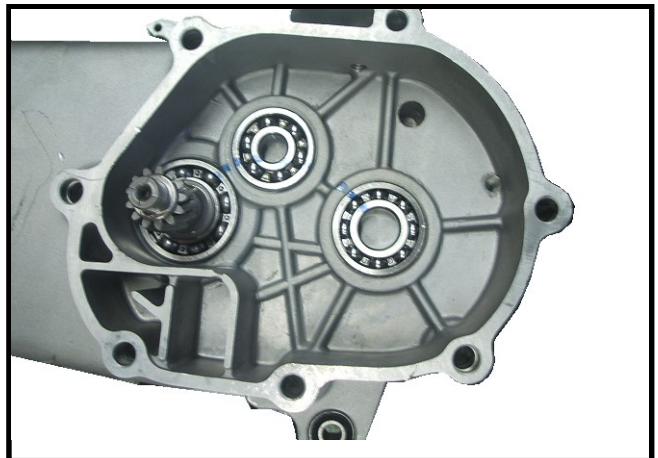
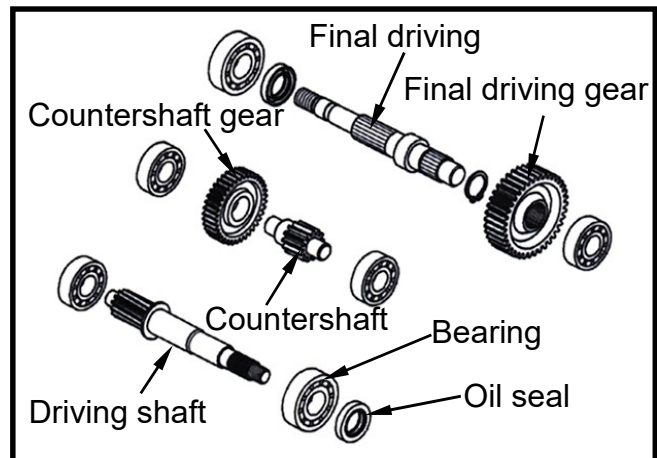

Press out the driving shaft from the crankcase.
 Remove oil seal from the gear box.
 Remove the driving shaft bearing from the gear box cover with the inner type bearing puller.

⚠ Caution

Using the bearing protector as pressing out the driving shaft from the left crankcase.

Specified tool:

Inner type bearing puller.

If the driving shaft is pulled out with its bearing, then remove the bearing with bearing puller and bearing protector.

Tool:

Multi-functional bearing puller
 Bearing protector

Install a new driving shaft bearing onto crankcase.

Then, install the driving shaft.

Specified tool:

Press the bearing in with C type hydraulic presser or bearing installer.

Install a new final driving shaft bearing onto gear box cover.

Specified tool:

Press the bearing in with C type hydraulic presser or the bearing installer.
 Apply with some grease onto the lip section of oil seal and then install the seal.

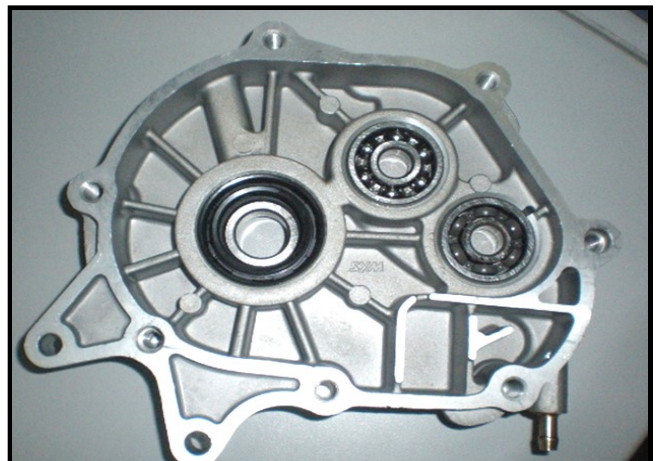
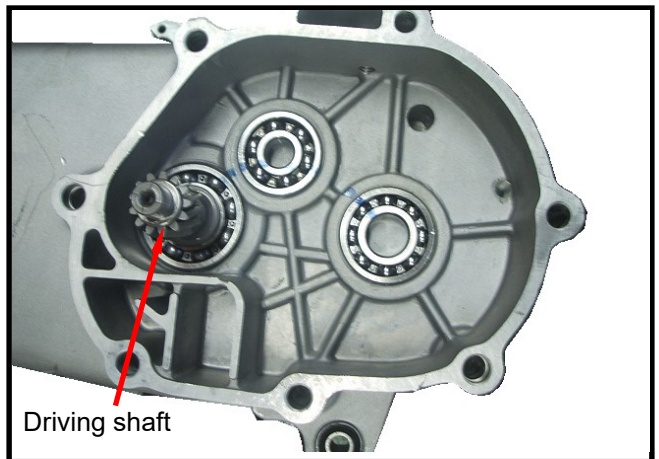
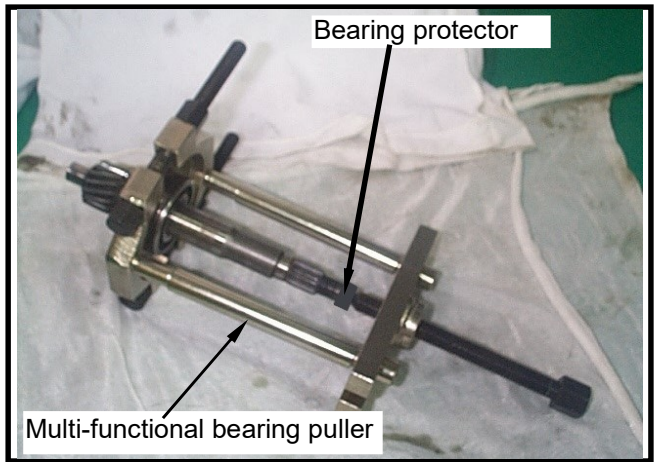
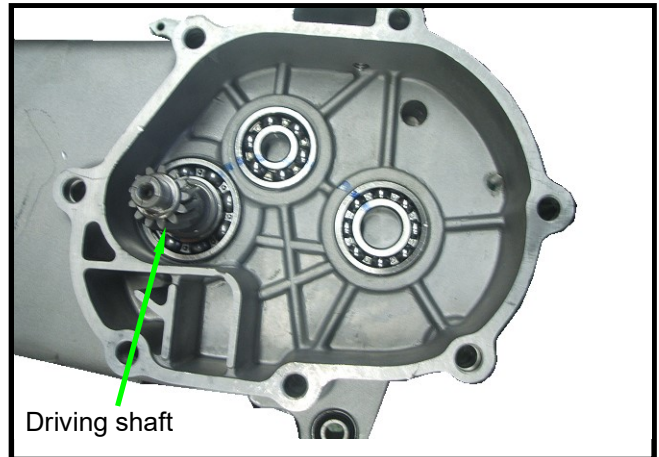

RE-ASSEMBLY OF FINAL DRIVING MECHANISM

Install final shaft and final shaft driven gear, countershaft.

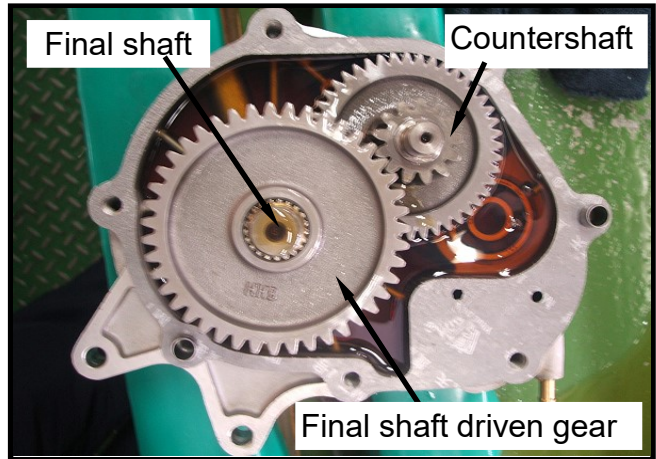

Install the setting pins(2 pins) and new gasket.

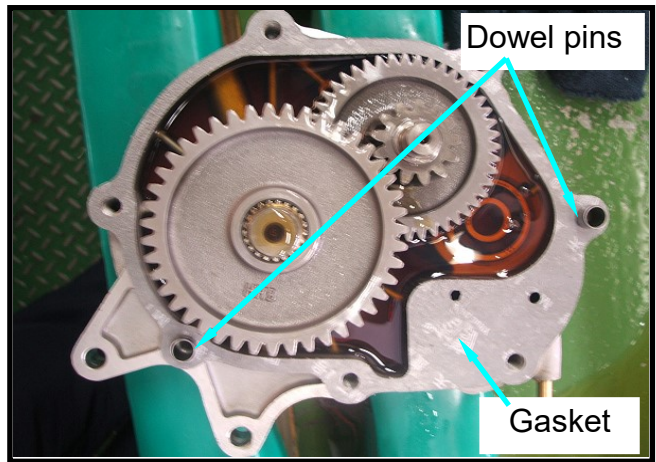

Apply with grease onto the oil seal lip of final driving shaft.

Install the gear box cover and 7 bolts. (tighten the bolts)

Torque: 0.8~1.2 kgf-m

Install the clutch/sliding driving pulley. Install the driving pulley, belt and left crankshaft cover.

Install the rear wheel.

Add gear oil.

Recommended usage: SAE 85W-140

(180 cc: standard capacity)

(170 cc: when replacement)

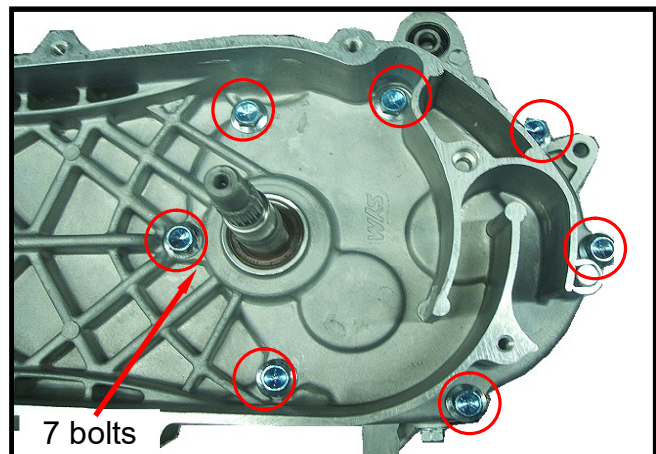
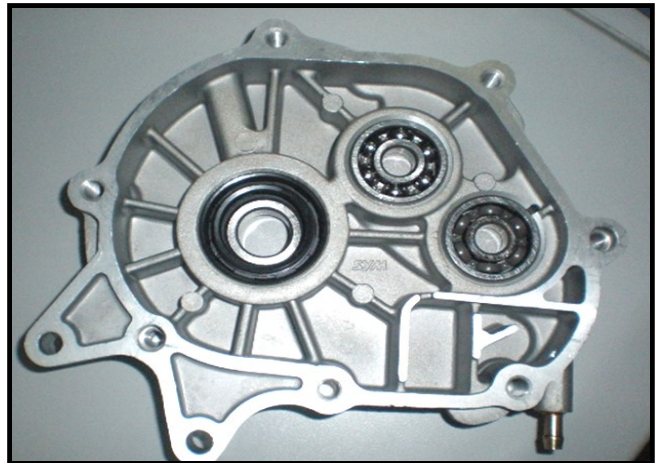

MECHANISM DIAGRAM	10-1	RIGHT CRANKCASE COVER	
PRECAUTIONS IN OPERATION	10-2	INSTALLATION	10-8
A.C.GENERATOR REMOVAL	10-3	MOUNTED COIL SET	
RIGHT CRANKCASE COVER		INSTALLATION	10-8
REMOVAL	10-4	FLY WHEEL INSTALLATION.....	10-8
STARTING CLUTCH.....	10-5		

MECHANISM DIAGRAM

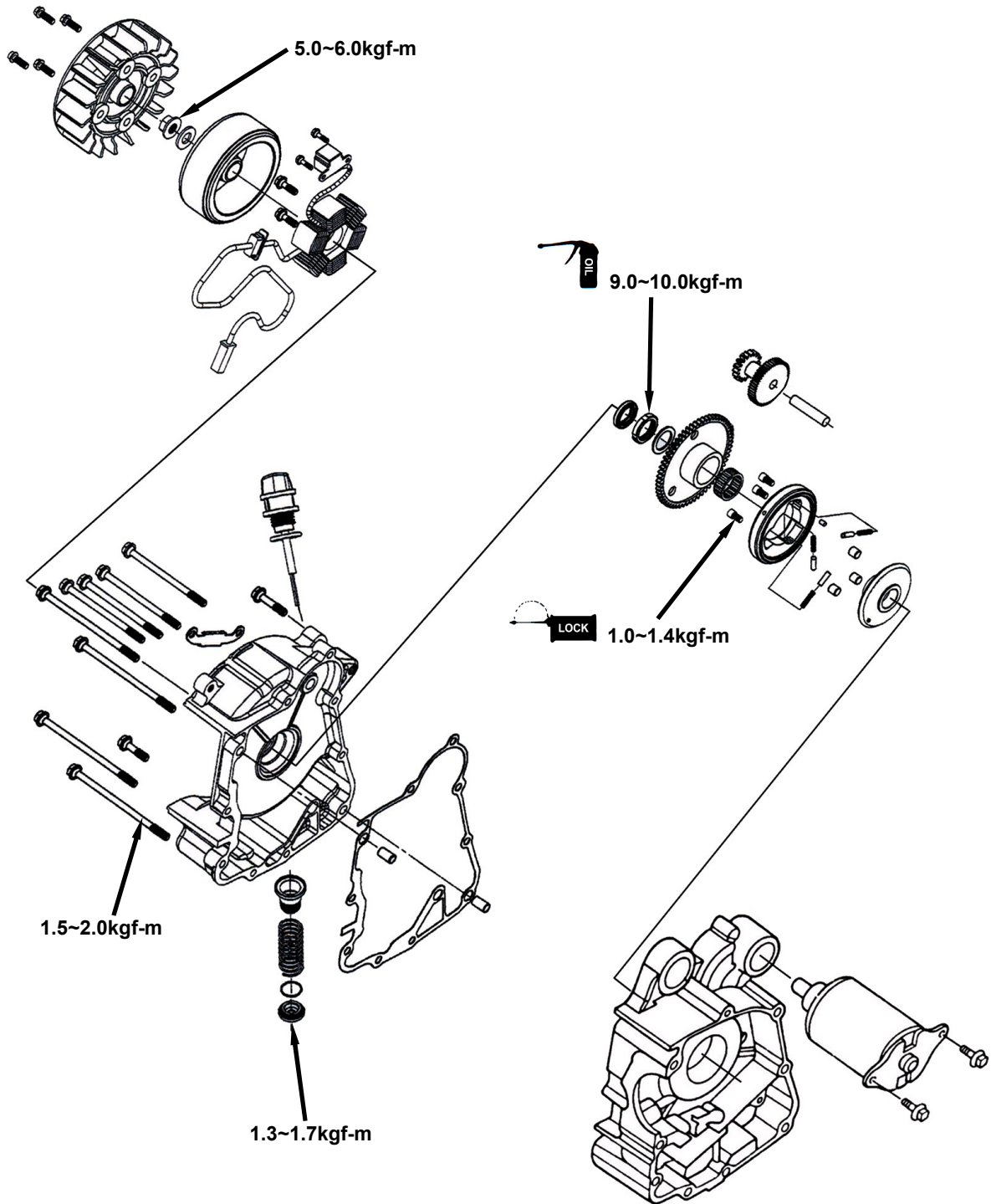

PRECAUTIONS IN OPERATION

General information

- Refer to chapter 5: Engine removal and installation
- Refer to chapter 1: The troubleshooting and inspection of A.C. generator
- Refer to chapter 16: The service procedures and precaution items of starter motor

Specification

Unit: mm

Item	Standard value	Service Limit
ID of starting driven gear	32.0	32.060
OD of starting clutch cover	28.0	27.940

Torque value:

Flywheel nut	5.0~6.0kgf-m
Exhaust muffler bolt 8 mm	1.5~2.0kgf-m
Oil screen cover	1.3~1.7kgf-m
Starting clutch hex lock nut	9.0~10.0kgf-m with oil on the thread
Starting clutch hex socket bolt	1.0~1.4kgf-m with adhesive

Special service tools

Flywheel puller
 Universal fixture

A.C. GENERATOR REMOVAL

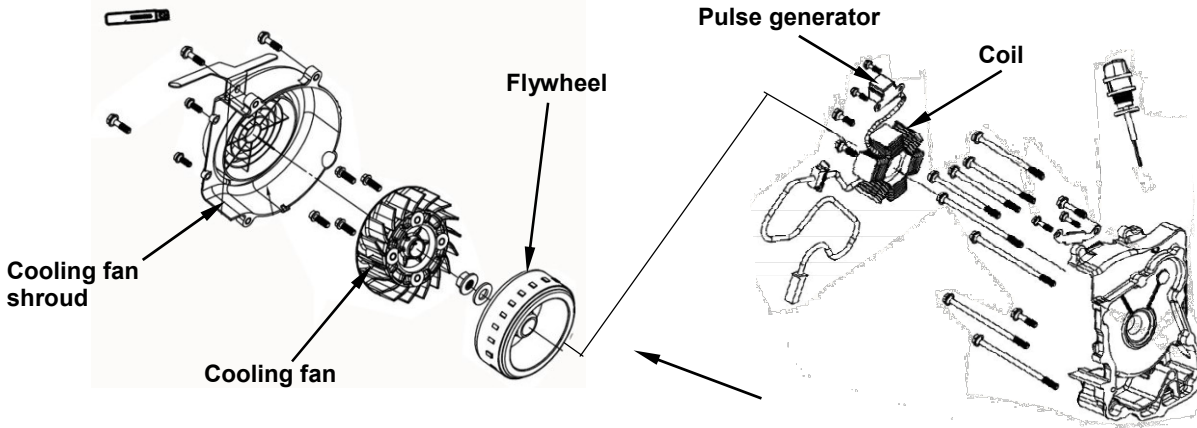

Drain out the engine oil.
Remove the body cover.
Remove the exhaust muffler. (2 bolts, 2 nuts)
Remove the fan shroud. (4 bolts)

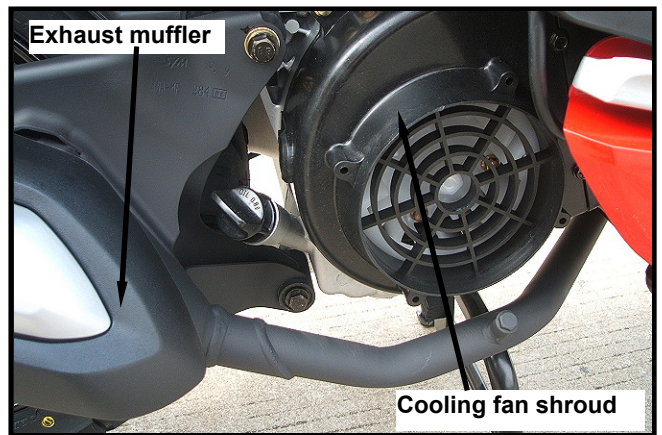

Remove the fan. (4 bolts)

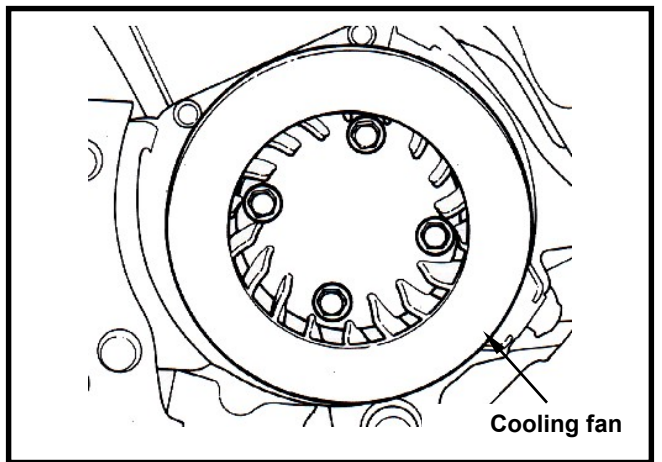

Hold the flywheel with the universal fixture.
Remove the 10mm nut on the flywheel.

Special Service Tools:
Universal Fixture

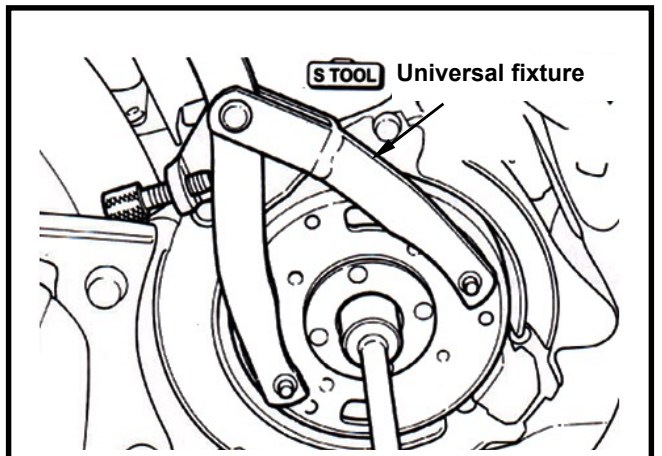

Remove the flywheel with the flywheel puller.

Special service tools:

Flywheel puller

Shaft protector

⚠ Caution

Install a shaft protector on the right end of crankshaft to avoid damaging the crankshaft before installing the flywheel puller.

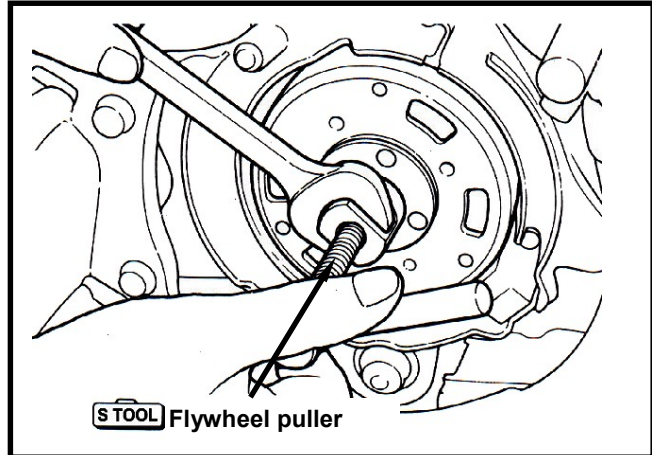

Remove the connectors of the A.C. generator and pulse generator.

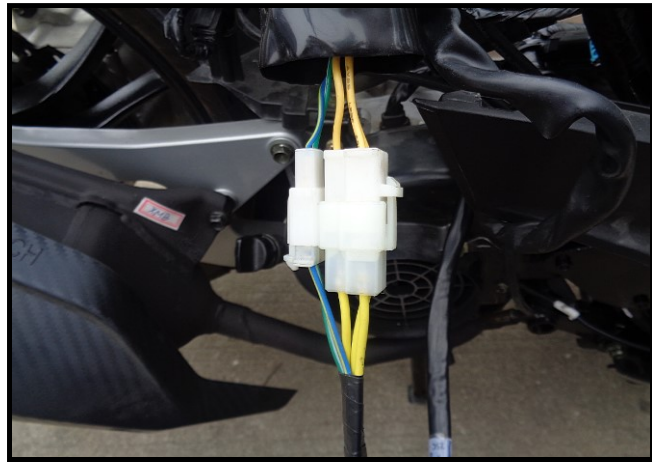

Remove the 6 bolts for the pulse generator, the A.C. generator coil and cable guide. Then, remove the A.C. generator assembly.

⚠ Caution

Do not damage the alternator coil.

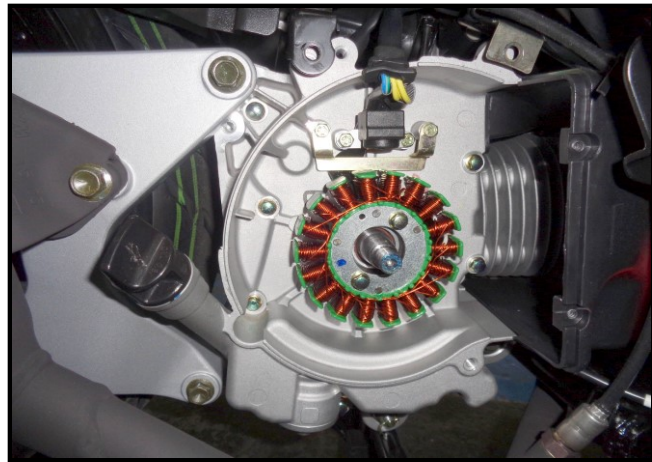

RIGHT CRANKCASE COVER REMOVAL

Remove the right crankcase cover. (6 bolts)
Remove setting pin and gasket.
Remove the gasket or foreign materials on the connection surfaces of both the cover and crankcase.

⚠ Caution

Do not damage the connection surfaces.

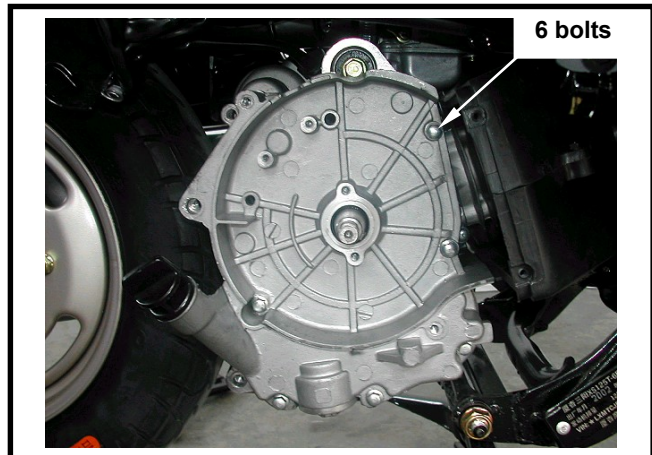

STARTING CLUTCH

Starting Clutch Removal

Hold the starting driven gear with the universal fixture.

Remove the 22mm anti-loosen lock nut and gasket.

Special service tools:

Anti-loosen lock nut socket

Universal fixture.

⚠ Caution

The mounting nut is left-turn thread.

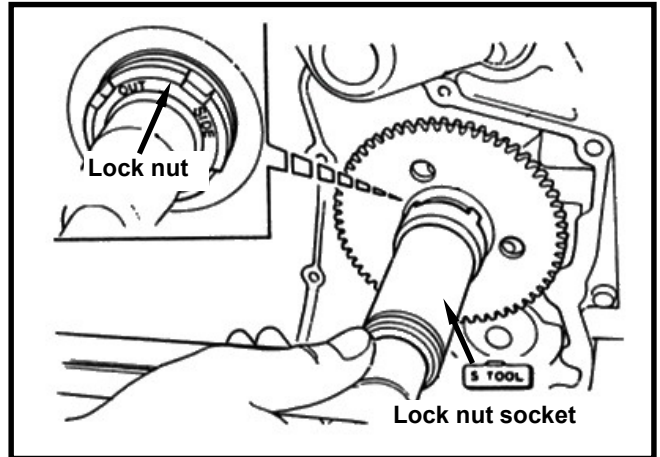

Remove the starting driven gear.

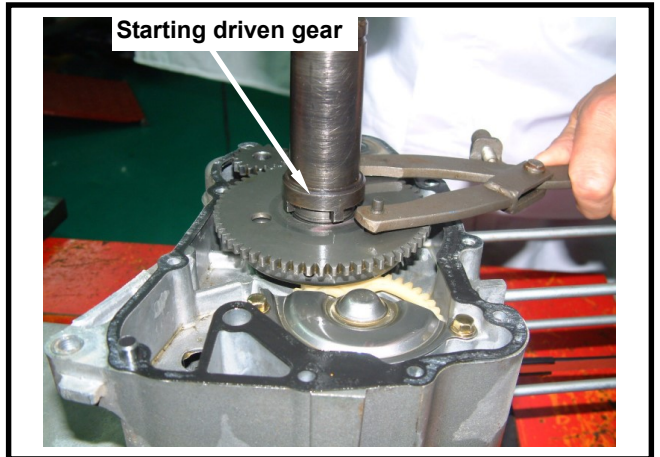

Remove starting clutch, starting reduction gear, and shaft.

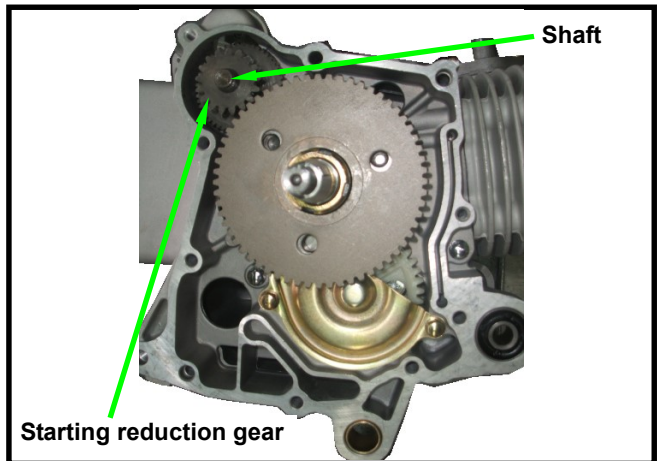

Starting Clutch Inspection

Install the starting clutch onto the starting driven gear.

Hold the starting clutch and turn the starting driven gear.

The starting driven gear should can be turned in the motion of C.W. and can not be turned in C.C.W.

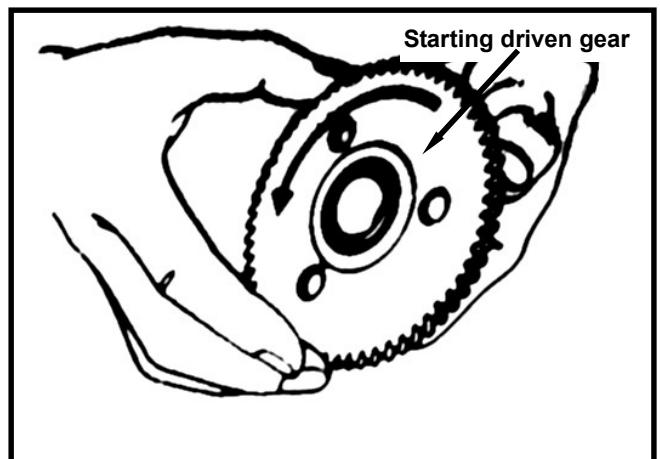

Check the starting driven gear for wear or damage.

Measure the ID of the starting driven gear.

Service Limit:

ID: 32.06 mm or less

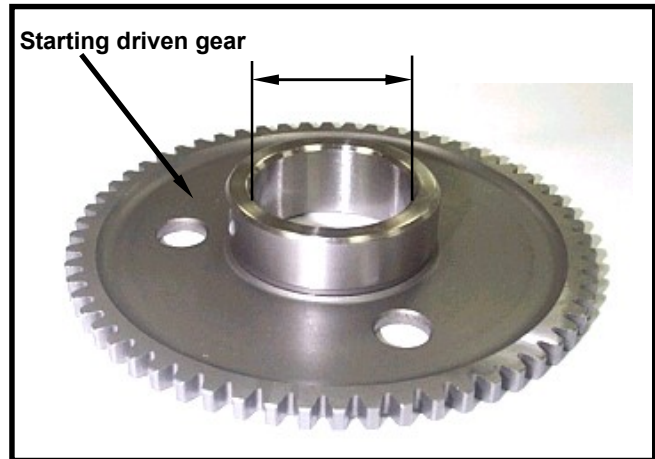

Check the starting reduction gear and shaft for wear or damage.

Measure the ID of the starting reduction gear.

Service Limit:

ID: 10.05 mm or less

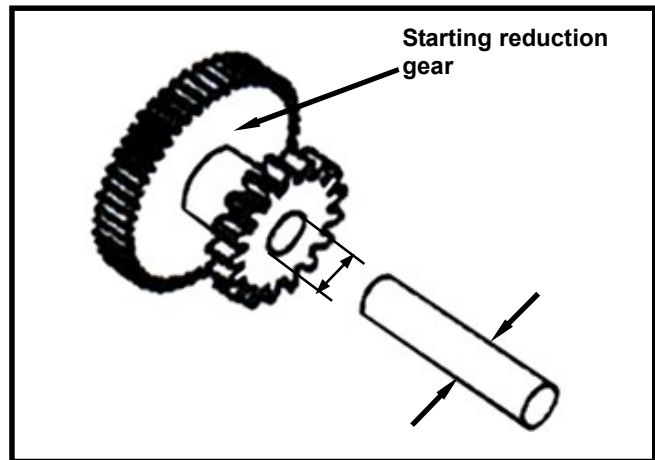

Measure the OD of the starting reduction gear shaft.

Service Limit:

OD: 9.94 mm or above

Disassembly

Remove the hex bolts (3 bolts) inside the starting clutch.

Separate the clutch body and the clutch cover.

Remove the rollers, plugs, and springs on the one way clutch.

Check each rollers and plugs for wear or damage.

Install rollers, plugs and springs.

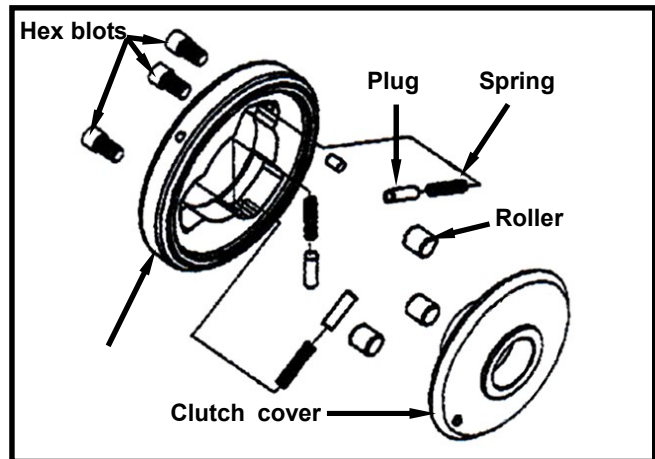

Measure the OD of the starting clutch cover.

Service Limit:

OD: 27.94 mm or above

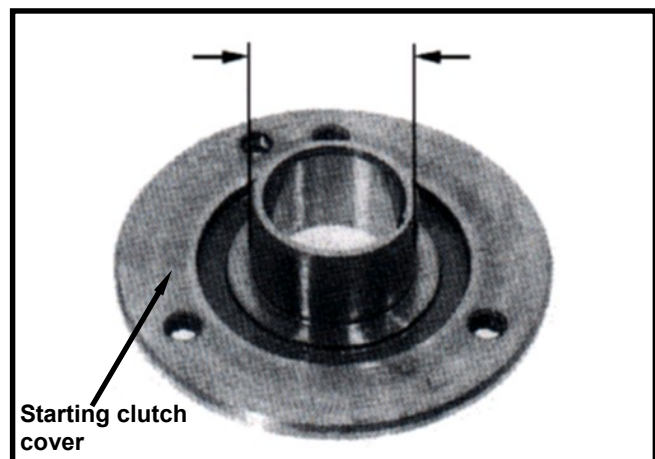

Installation

Install the components in the reverse procedures of removal.

⚠ Caution

Add adhesive onto the thread of hex socket bolt.

Torque value: 1.0~1.4kgf-m

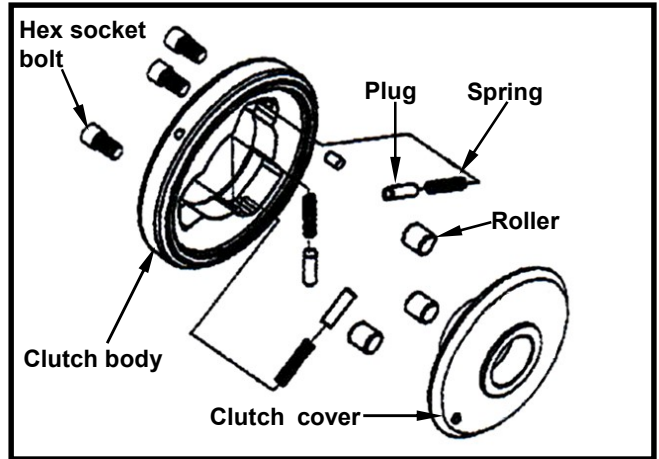

Starting clutch Installation

Install reduction gear shaft and reduction gear.
Install starting clutch.

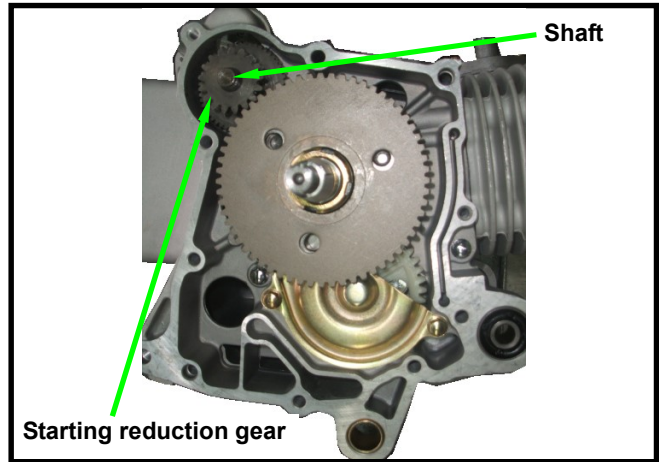

Install the starting clutch outer and starter driven gear.

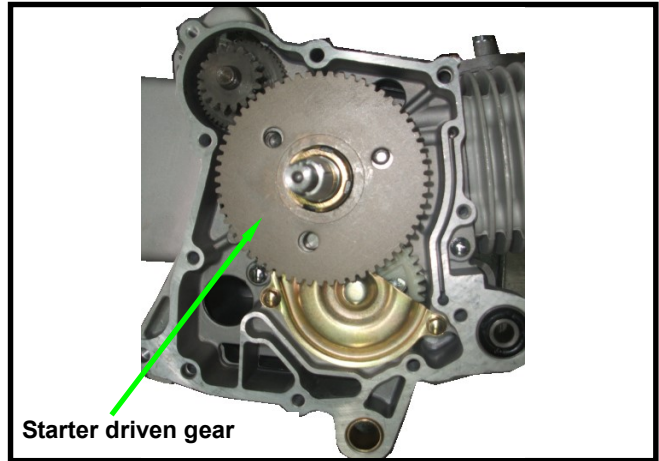

Hold the starting driven gear with the universal fixture.
Tighten the 22mm anti-loosen lock nut and gasket.

⚠ Caution

Add engine oil onto the thread of lock nut.

Special service tools:
Anti-loosen lock nut socket
Universal fixture
Torque value: 9.0~10.0kgf-m

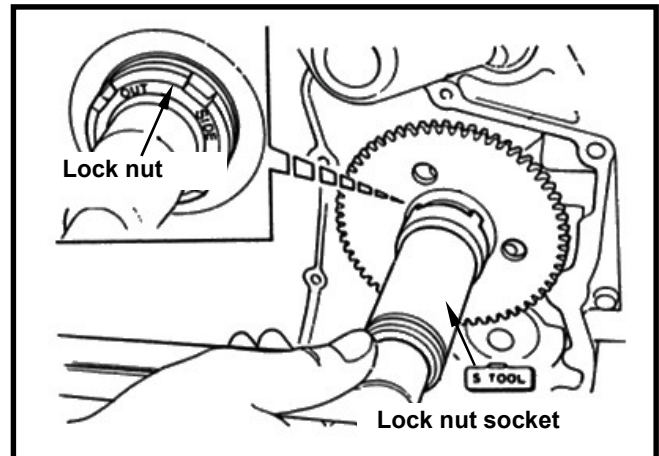

RIGHT CRANKCASE COVER INSTALLATION

Install setting pin and new gasket on the crankcase.

Replace the right crankshaft oil seal of the crankcase and apply some oil onto the oil seal lip.

Install right crankcase cover onto the right crankcase. (8 bolts)

Torque value: 1.5~2.0kgf-m

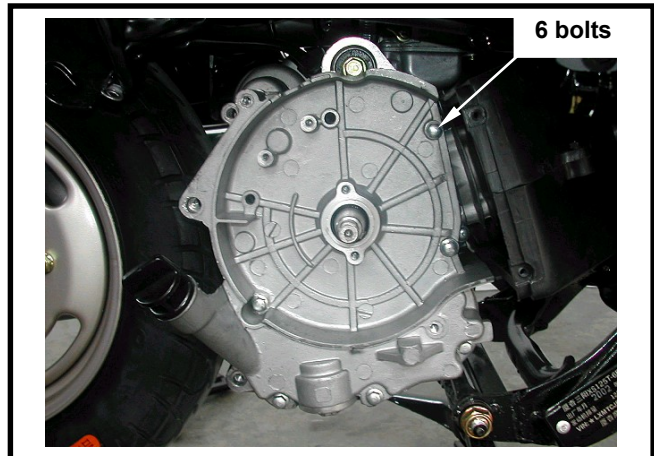

MOUNTED COIL SET INSTALLATION

Install the coil set onto right crankcase cover. (2 screws)

Install pulse generator. (2 screws)

Tighten the cable guide. (2 screws)

Torque: 1.5~2.0kgf-m

Tie the wire harness hose onto the indent of crankcase.

⚠ Caution

Make sure that the wire harness is placed under the pulse generator.

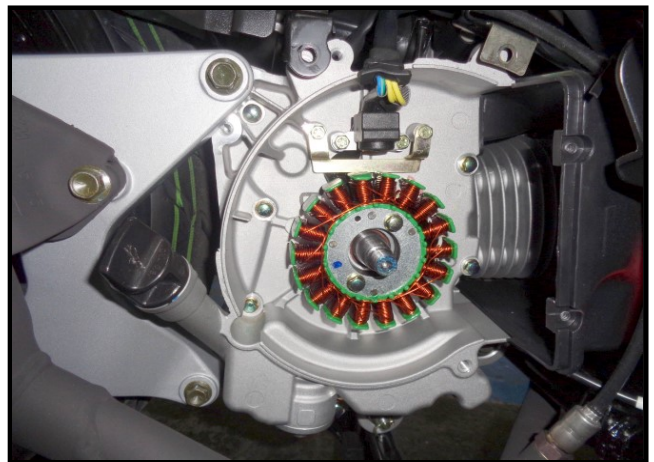

Install A.C. generator connector and pulse generator connector.

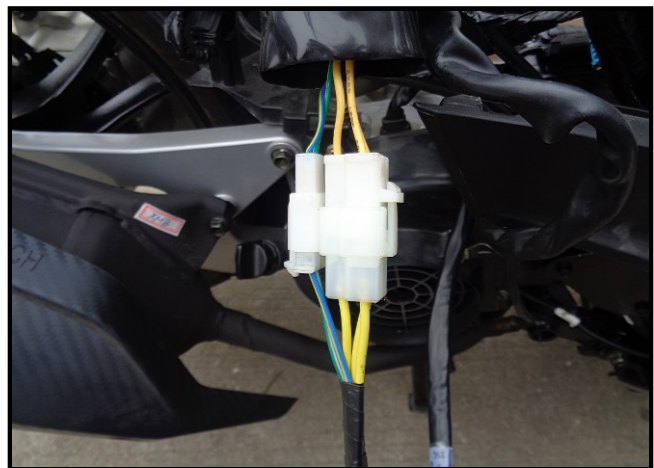

FLYWHEEL INSTALLATION

Make sure that there is no magnetic powder.
If so, clean up it.

Align insert on crankshaft with the flywheel groove, and then install the flywheel.

Hold the flywheel with flywheel holder, and tighten its nut.

Torque value: 5.0~6.0kgf-m

Special service tool:

Universal fixture

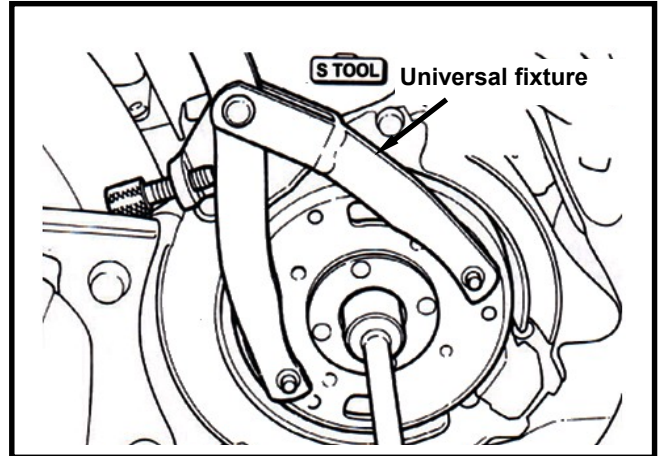

Check the clearance between the sensor and flywheel

Clearance: 0.7~0.9mm

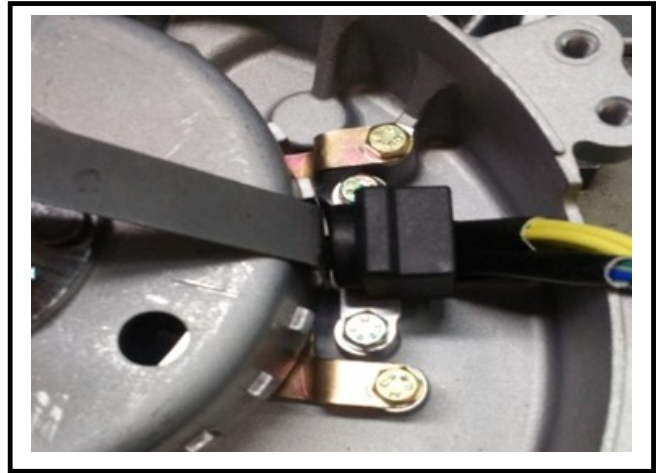

Install the cooling fan. (4 bolts)

Torque value: 0.8~1.2kgf-m

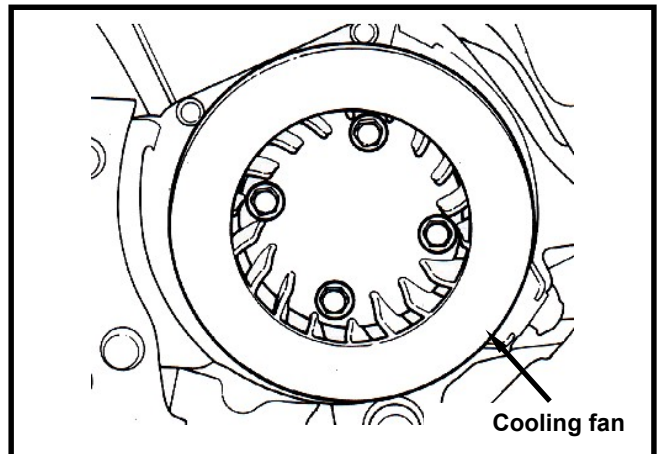

Install the cooling fan shroud. (4 bolts)

Install the exhaust muffler. (2 bolts, 2 nuts)

Install the body cover.
Add some engine oil according the specified quantity.

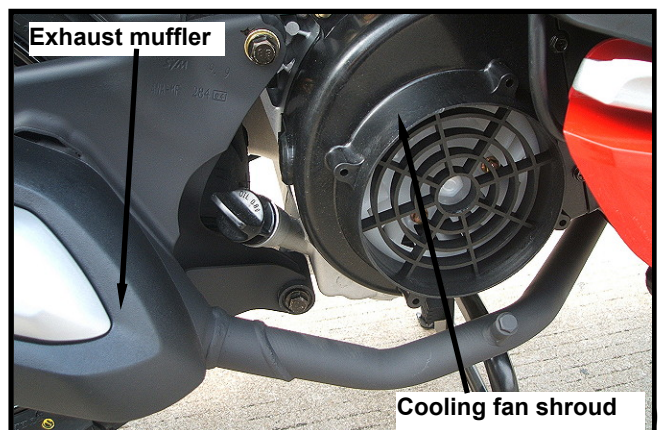

MECHANISM DIAGRAM..... 11-1	DISASSEMBLY OF CRANKCASE 11-3
OPERATIONAL PRECAUTIONS... 11-2	CRANKSHAFT INSPECTION..... 11-5
TROUBLE DIAGNOSIS 11-2	ASSEMBLY OF CRANKCASE 11-6

MECHANISM DIAGRAM

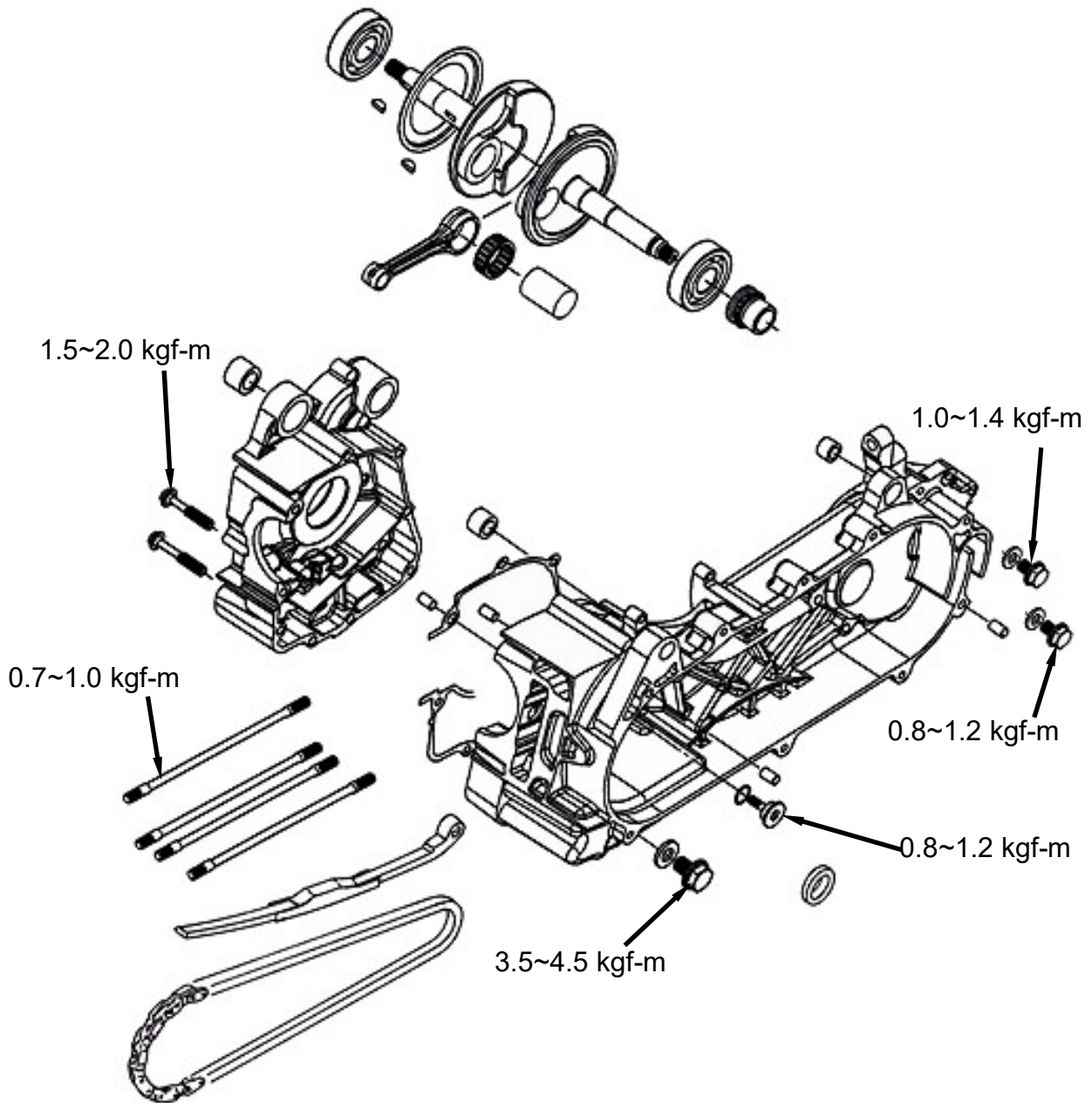

OPERATIONAL PRECAUTIONS

General Information

- This Section contains descriptions concerning disassembly of the crankcase so that the crankshaft can be serviced.
- Complete following operations before disassembling crankcase.

Engine	Chapter 5
Cylinder head	Chapter 6
Cylinder and piston	Chapter 7
V-belt Drive pulley	Chapter 8
AC generator/ Starting Clutch	Chapter 10
Start motor	Chapter 16
- If the crankshaft bearing or timing sprocket need be replaced, then the crankshaft set have to replaced.

Specification

Unit: mm

Item	Standard	Limit
Left, right clearance of the big end of the connecting rod	0.100~0.350	0.550
Radial clearance of the big end of the connecting rod	0.000~0.008	0.050
Run-out	Left side: Below 0.035 Right side: Below 0.035	Left side: 0.035 Right side: 0.030

Torque value

Bolts for crankcase	1.5~2.0 kgf-m
Bolts for cylinder/cylinder head	0.7~1.0 kgf-m
Engine oil draining plug	3.5~4.5 kgf-m
Bolts for cam chain tensioner	0.8~1.2 kgf-m

Special Service Tools

Crankcase remover/set
 Crankshaft installation puller
 Inner type bearing puller
 Outer type bearing puller
 Bearing pressing tools
 Oil seal pressing tools

TROUBLE DIAGNOSIS

Engine noise

- Loose crankshaft bearing
- Loose crankshaft pin bearing
- Wear piston pin or piston pin hole

DISASSEMBLY OF CRANKCASE

Remove the 2 bolts from the right crankcase.

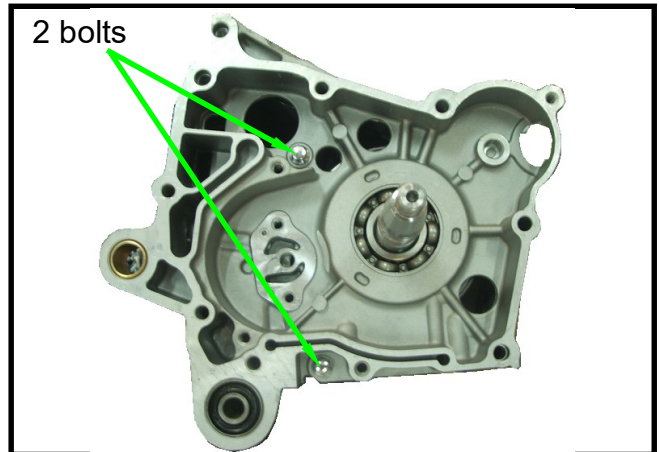

Remove the cam chain tensioner (hex socket bolt) from the left side of crankcase.

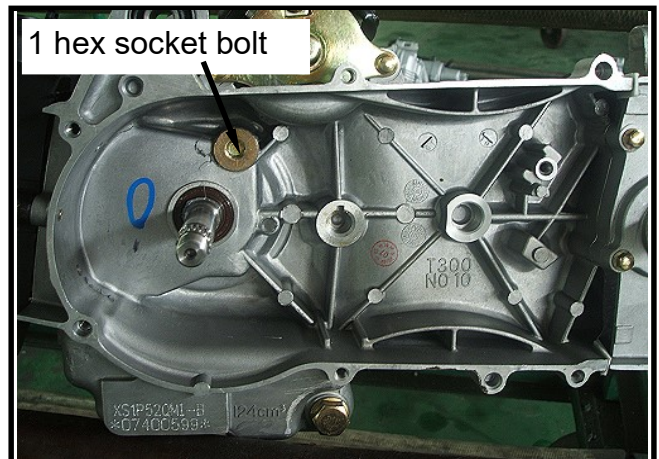

Place the left side of crankcase upward, and then install the crankcase remover/set onto the crankcase.

Drive the screw of the crankcase remover/set into the crankcase, and then separate the left and the right crankcases. Remove the cam chain.

⚠ Caution

- Never pry out the connection surfaces of crankcases as separating. Otherwise, the connection surfaces could be damaged and cause oil leaking.
- It have to separate the cam chain and the drive gear before pressing out the both left and right crankcases.

Special Service Tools:
Crankcase remover/set

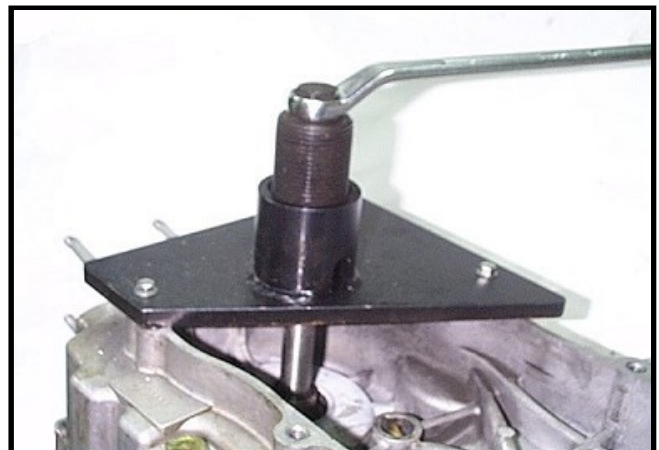

Remove the crankshaft from the right crankcase.

⚠ Caution

- The left and right bearings of crankshaft is to press-fit onto the crankshaft.



Remove gasket and dowel pins (2).
Scrape gasket residues off the crankcase contact surface.

⚠ Caution

- Do not damage contact surface of the crankcase.
- Soap the gasket residues into solvent and the residues will be removed easily.

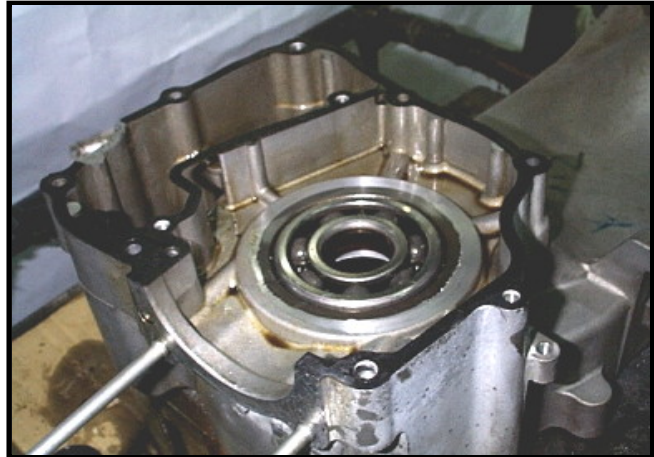

Remove oil seal from the left crankcase.

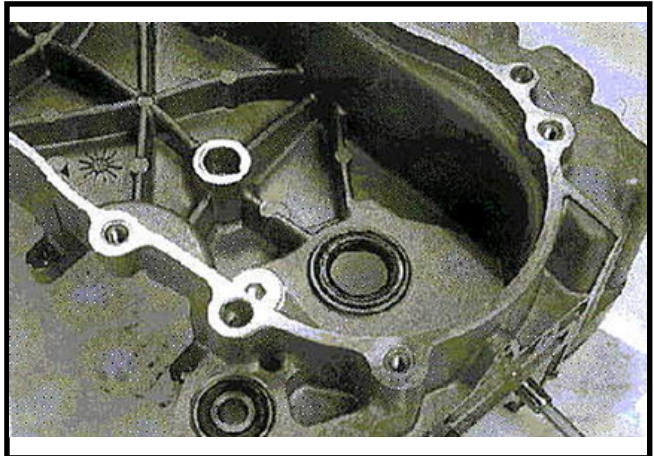

CRANKSHAFT INSPECTION

Measure left and right clearance of connecting rod big end.

Service limit: Replace when it is more than 0.55 mm

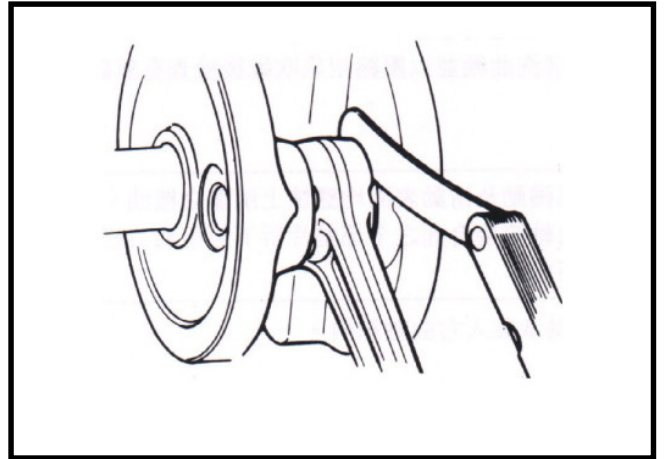

Measure the radial clearance of the big end at the vertical directions.

Service limit : 0.05 mm

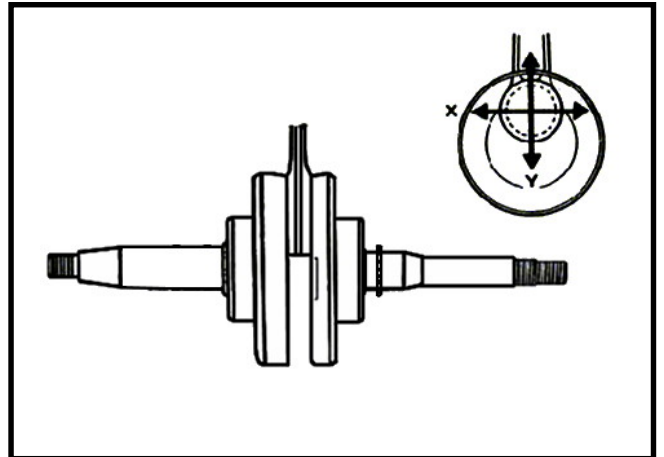

Place the crankshaft onto a V-block and measure run-out of the crankshaft with dial gauge.

**Service limit: Left side: 0.035mm
Right side: 0.030mm**

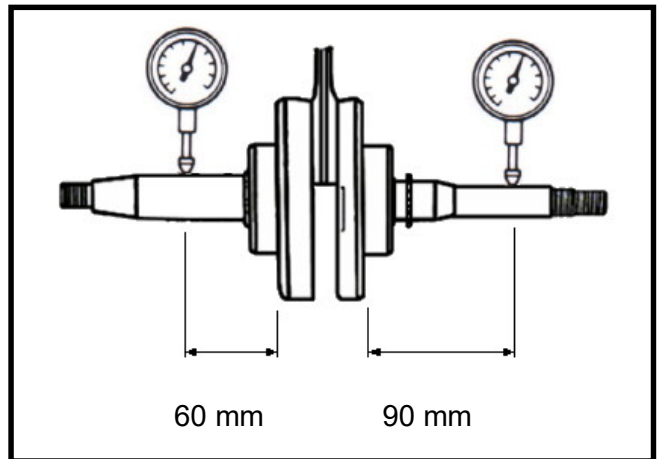

Bearing Inspection

Rotate the bearing with fingers and make sure the bearing can be rotated smoothly and quietly.

Check if the inner ring is connected onto the crankshaft tightly.

Replace crankshaft as a set when noise or looseness is detected.

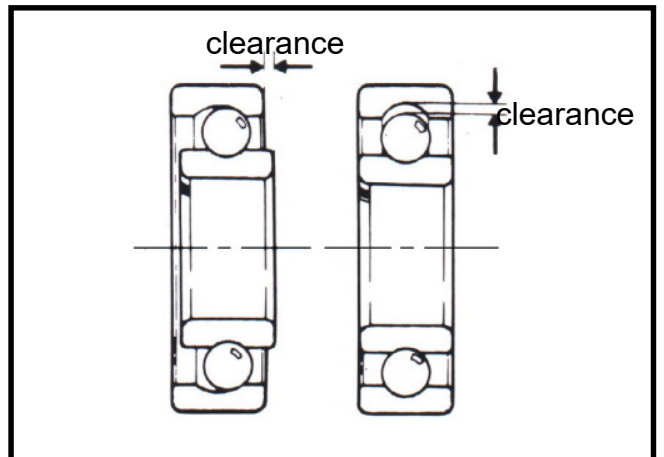

ASSEMBLY OF CRANKCASE

Install cam chain into the chain hole of the left crankcase, and then split out the cam chain.

Caution

- Do not damage the cam chain as installing the crankshaft.

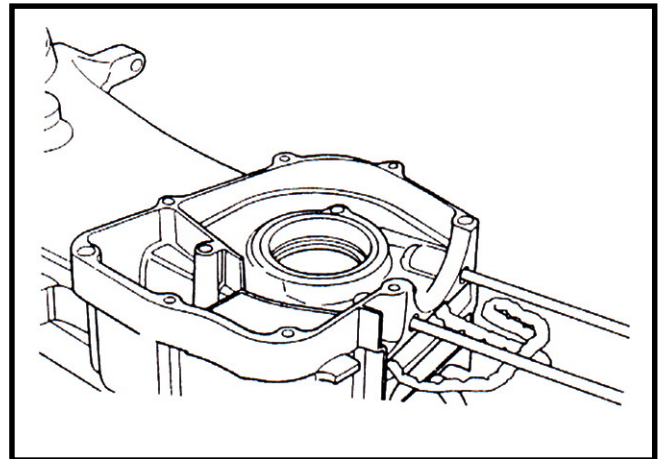

Install crankshaft into the left crankcase and then install two dowel pins and new crankcase gasket.

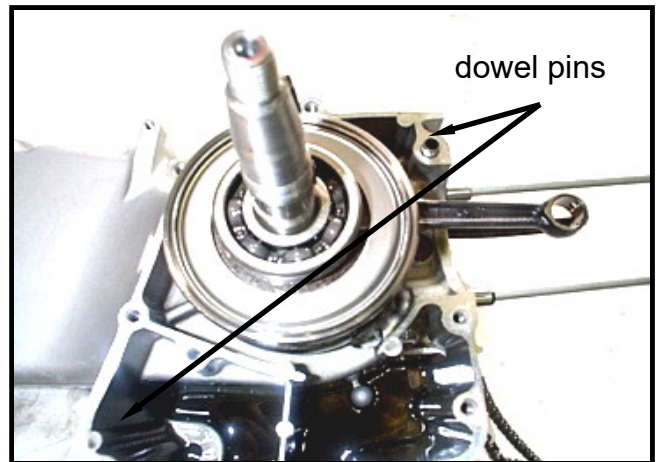

Install the right crankcase and tighten the crankcase bolts (2 bolts).

Torque value: 1.5~2.0 kgf-m

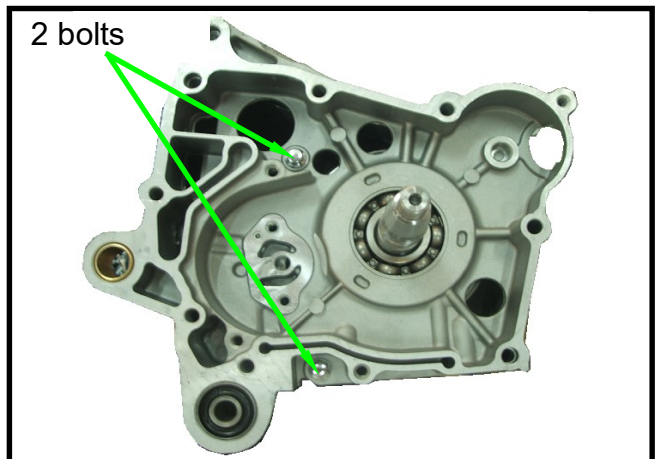

Install the cam chain tensioner.
Install a new O-ring onto the mounting bolt of the chain tensioner.
Apply some oil on the O-ring and tighten the bolt.

Torque value: 0.8~1.2 kgf-m

Caution

- The O-ring must be installed into the bolt's groove.

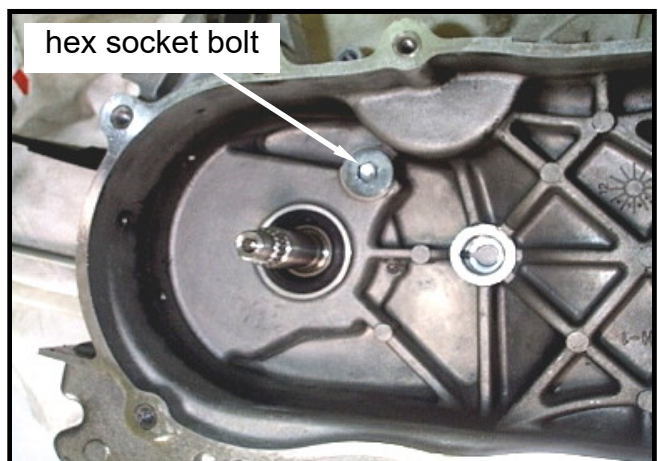

Apply with some grease onto the oil seal lip and then install it onto the left crankcase.



Press-fit the oil seal to specified position with the oil seal installer (19.8x30x5).
Special service tools: the oil seal installer (19.8x30x5)



MAINTENANCE INFORMATION.....	12-2	FRONT CENTER COVER.....	12-8
HANDLE COVER	12-3	LUGGAGE BOX	12-8
FRONT COVER.....	12-4	FLOOR PANEL	12-8
FRONT INNER BOX.....	12-5	SIDE COVER	12-9
BODY COVER/REAR CENTER COVER/REAR FENDER	12-6	UNDER COVER.....	12-10

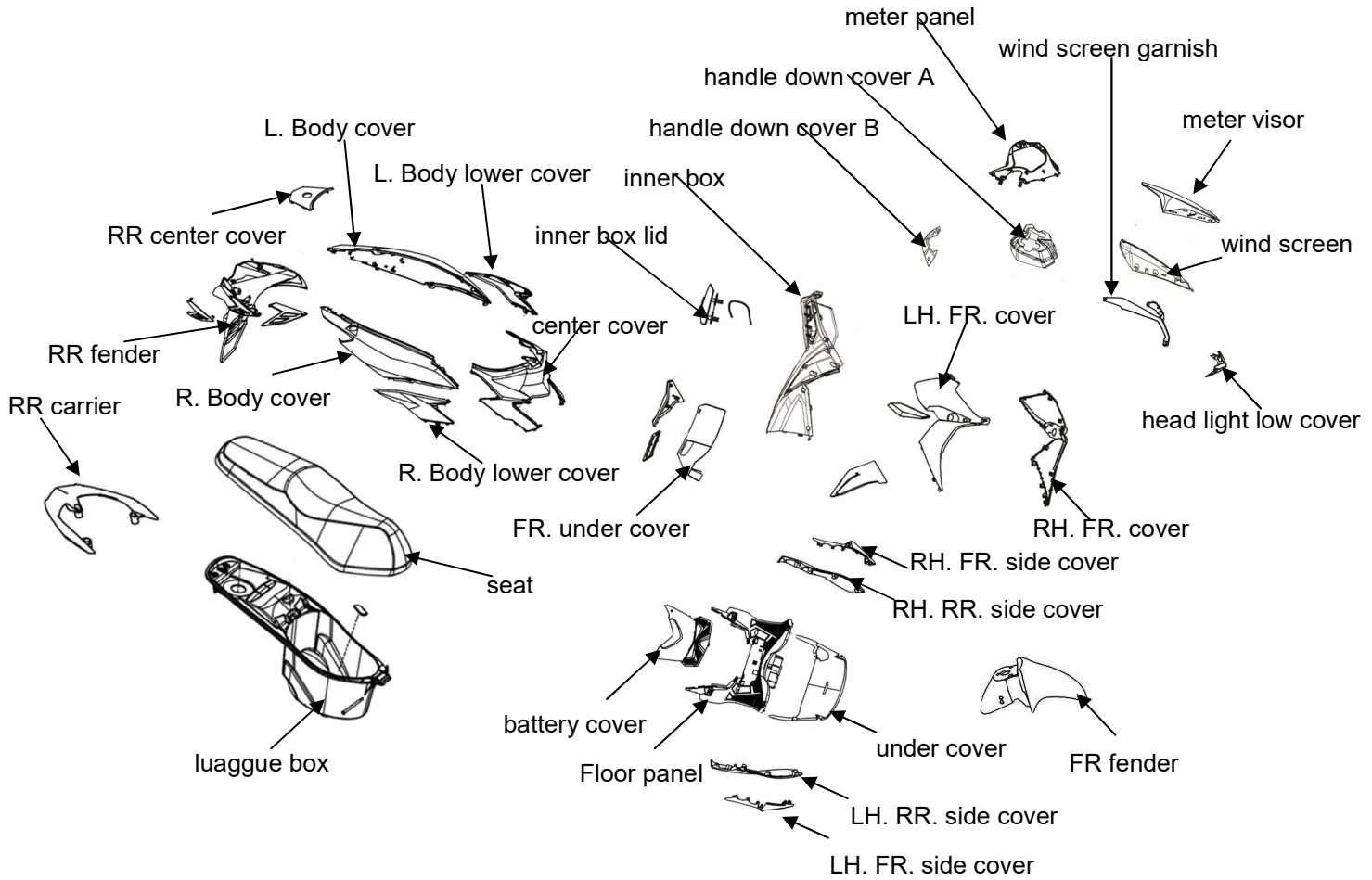

MAINTENANCE INFORMATION

Body covers disassemble sequence:

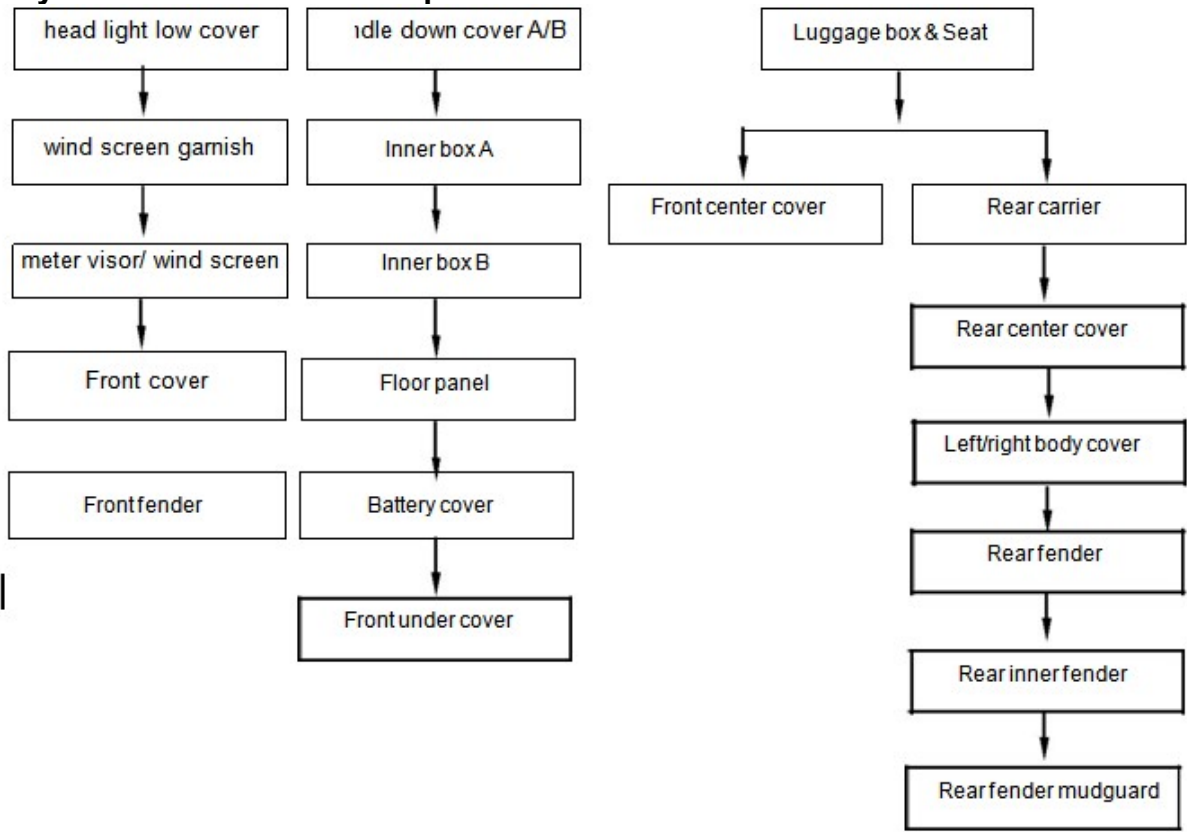

- Be careful not to damage various covers in disassembly or re-assembly operation.
- Never injure hooks molded on the body covers in disassembly or re-assembly operation.
- Align the buckles on the guards with slot on the covers.
- Make sure that each hook is properly installed during the assembly.
- Never compact forcefully or hammer the guard and the covers during assembly.

FRONT COVER

Removal wind screen garnish:
Remove 2 lower mounting screw of the head light low cover.

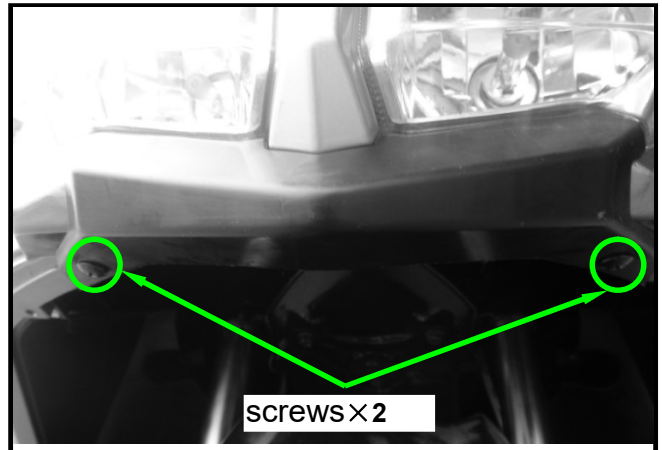

Remove the mounting screws to disassembly the wind screen garnish set

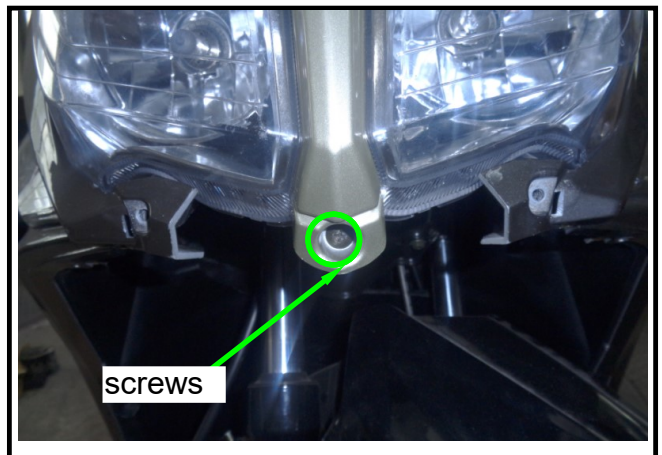

Remove the 2 mounting screws to disassembly the wind screen garnish set

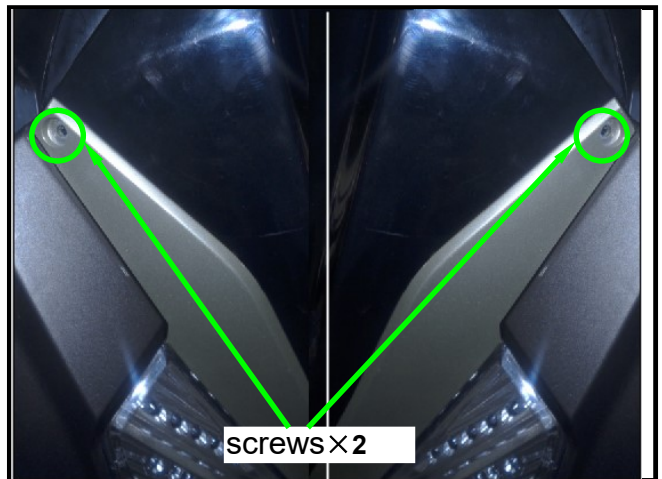

Disassembly the wind screen garnish

Installation:
Install according to the reverse procedure of removal.



FRONT COVER

Removal meter visor

Remove the 3 mounting screws between the right meter visor.

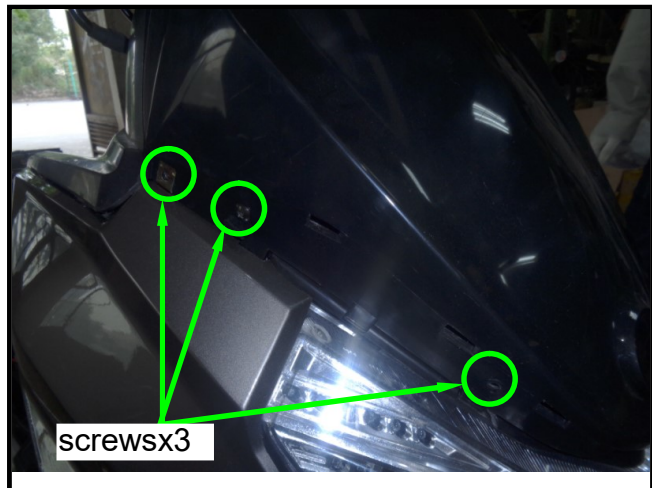

Remove the 3 mounting screws between the left meter visor.

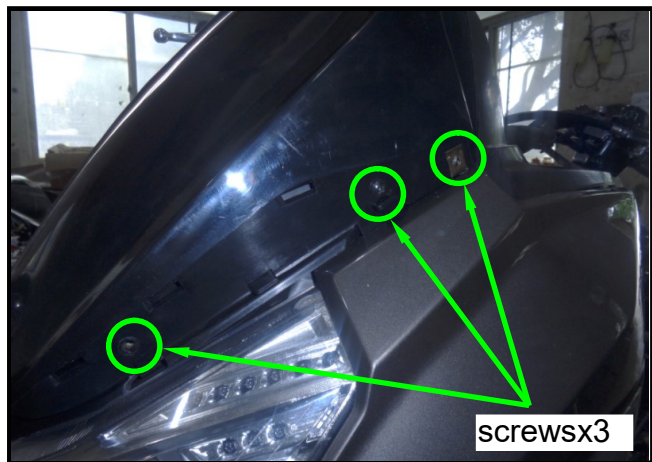

Disassembly the meter visor

Installation:
Install according to the reverse procedure of removal.



FRONT COVER

Removal wind screen

Remove the 9 mounting screws between the wind screen.

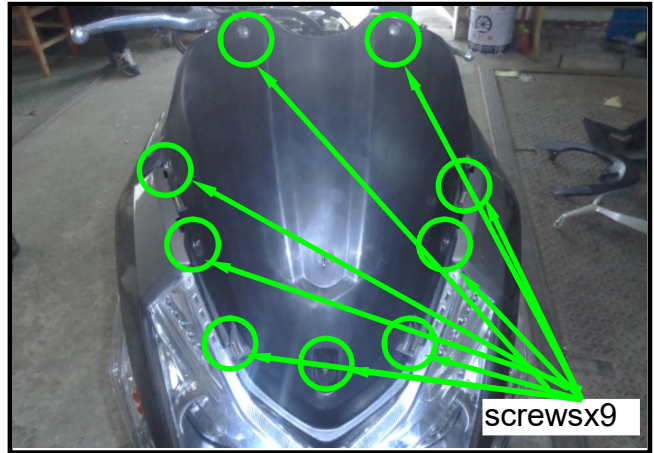

Disassembly the wind screen

Installation:

Install according to the reverse procedure of removal.



Removal Front Cover

Remove the mounting screw of left front side cover



Remove the mounting screw of right front side cover

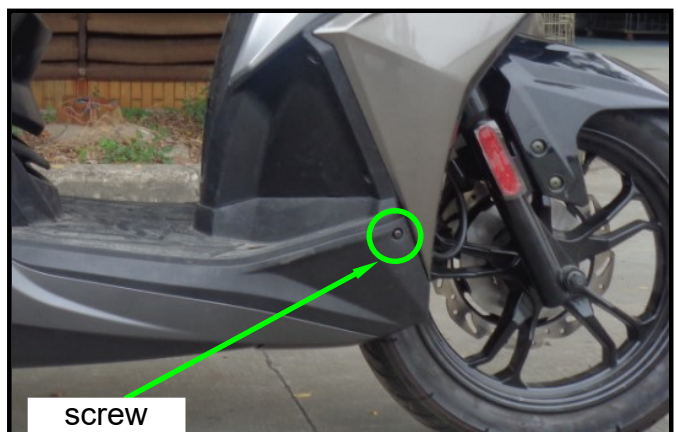

12. BODY COVER

SYM

Remove the 4 mounting screws of left front cover

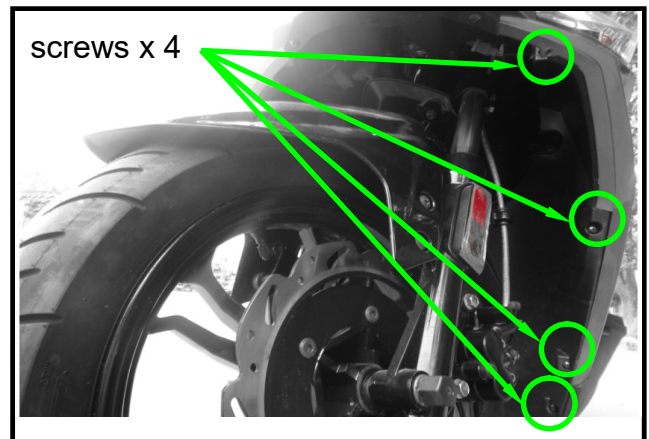

Remove the 4 mounting screws of right front cover

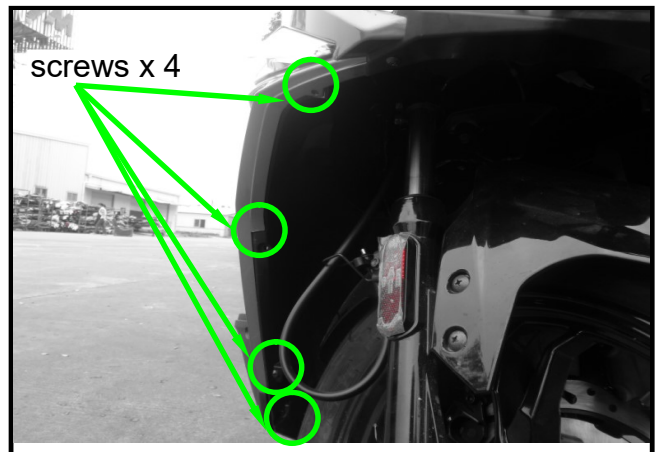

Remove the 3 mounting screws of inner box left upper side

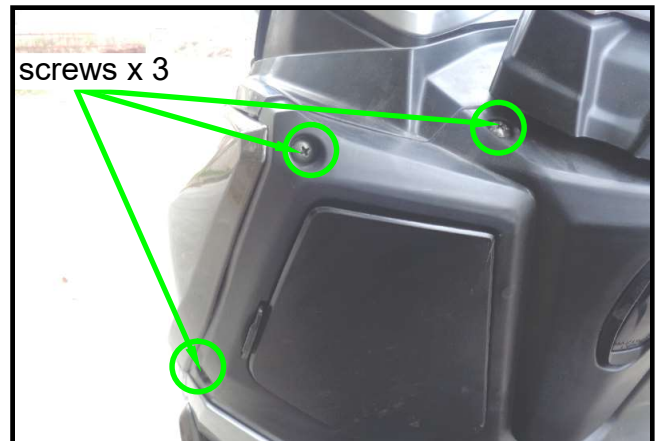

Remove the 3 mounting screws of inner box left under side

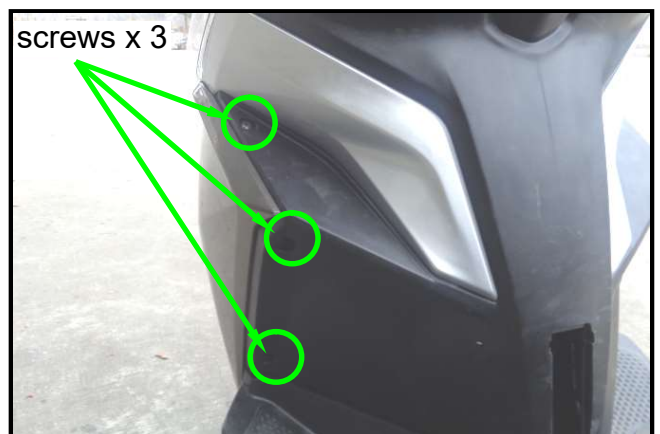

Remove the 3 mounting screws of inner box right upper side



Remove the 3 mounting screws of inner box right under side

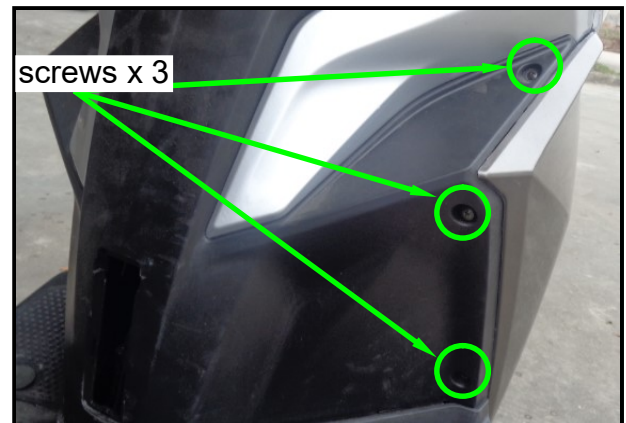

Push up the hook.



Remove the mounting bolt of inner cover

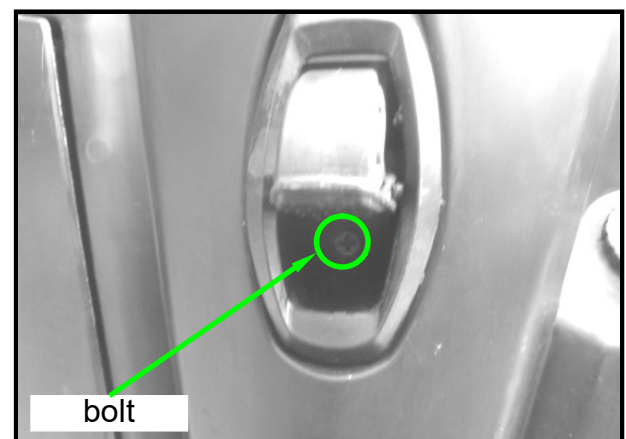

Remove the 2 mounting nuts of meter panel

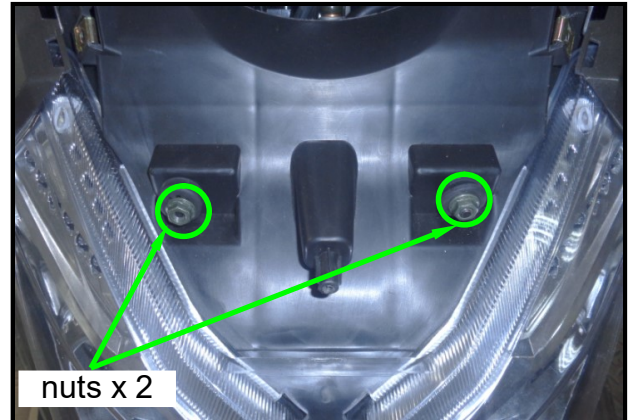

Remove the speed cable connecting

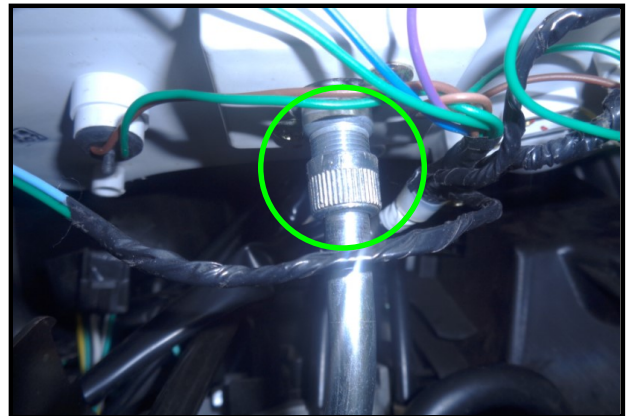

Remove the winker light connecting

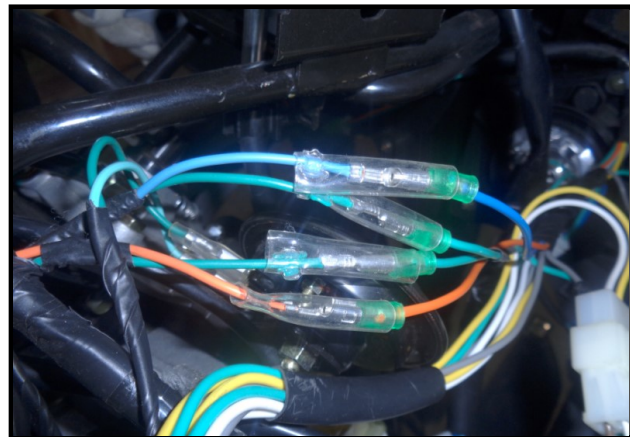

Remove the head light connecting



Disassembly the front cover

Installation:

Install according to the reverse procedure of removal.



Disassembly the meter, remove the 4 screws of the meter panel

Installation:

Install according to the reverse procedure of removal.

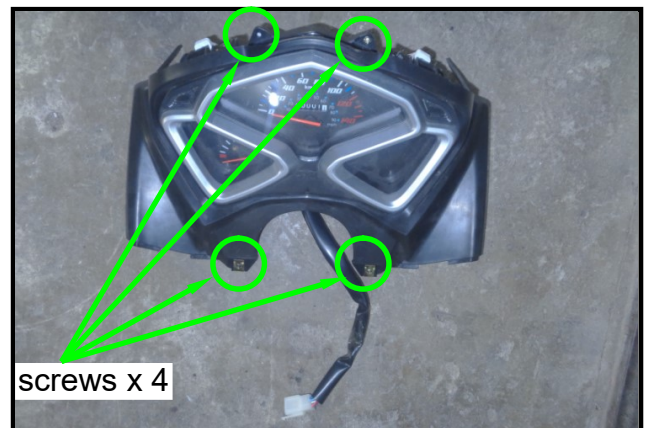

12. BODY COVER

SYM

BODY COVER

Remove the 4 mounting bolts of luggage box

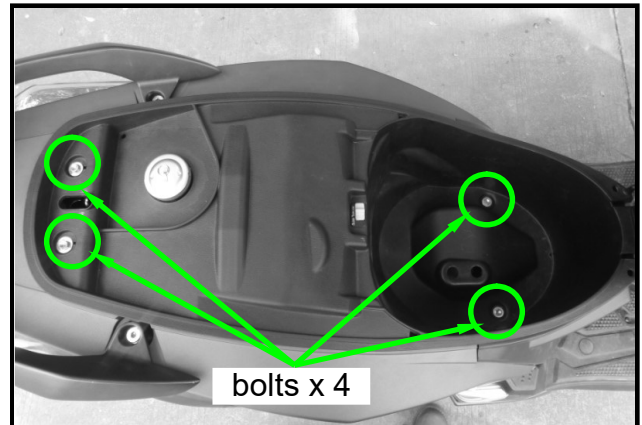

Be careful the engine stop switch connecting

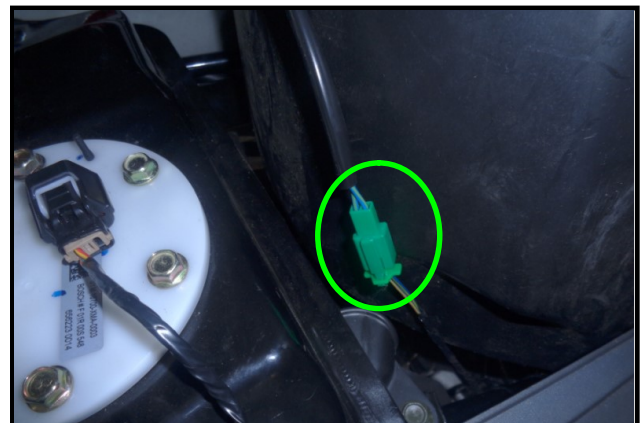

Remove the 3 mounting socket bolts of rear carrier

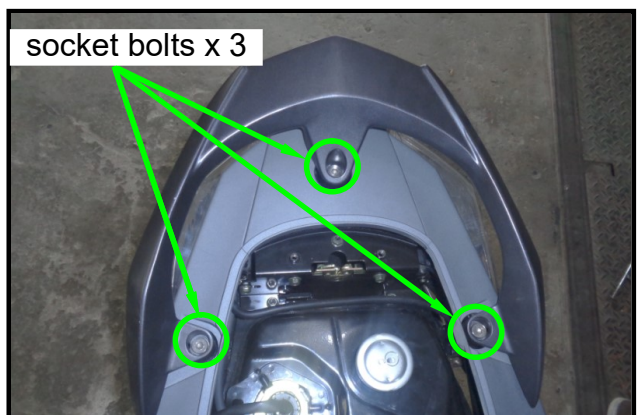

Remove the 2 mounting bolts of rear fender

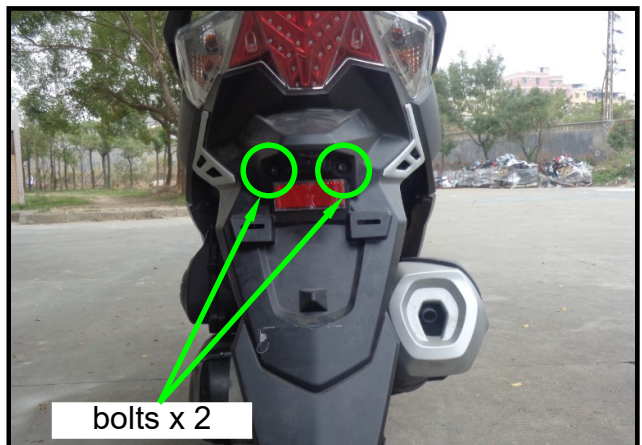

Remove the mounting screw between the right body cover and floor panel.

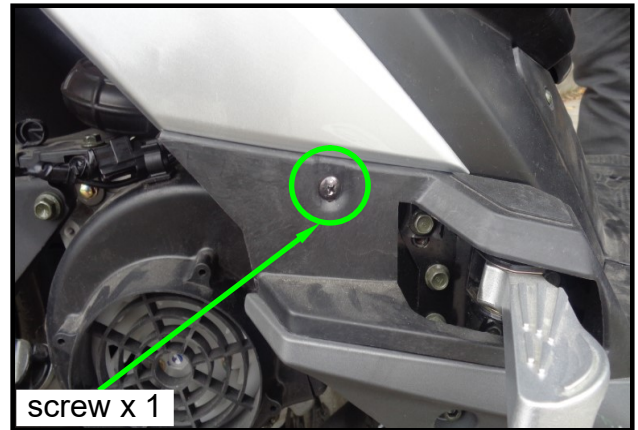

Remove the mounting screw between the left body cover and floor panel.

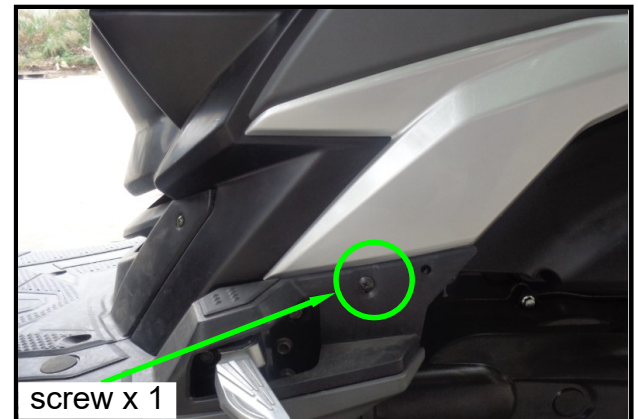

Remove the 2 mounting screws of center cover.

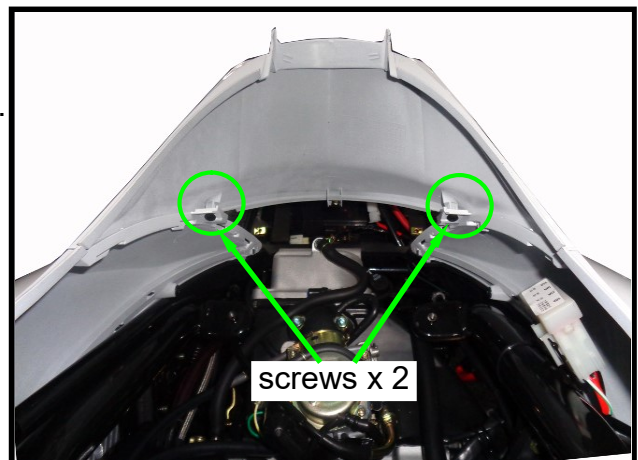

Remove the 6 mounting screws of battery cover.

Installation:

Install according to the reverse procedure of removal.

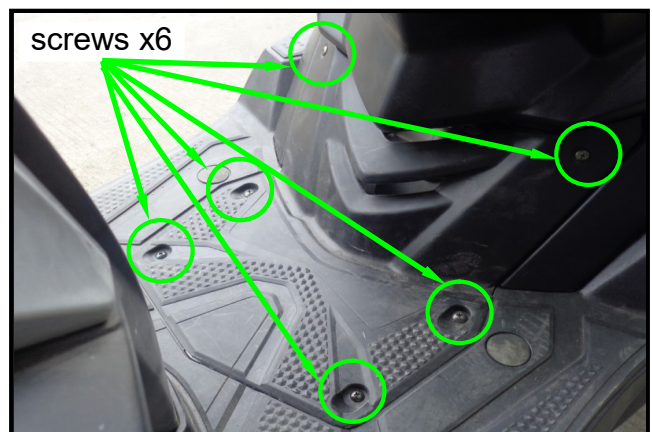

MECHANISM DIAGRAM-FRONT			
DISC BRAKE SYSTEM.....	13-1		
MECHANISM DIAGRAM-REAR			
DRUM BRAKE SYSTEM.....	13-2		
MAINTENANCE INFORMATION	13-3		
TROUBLE DIAGNOSIS	13-4		
HYDRAULIC BRAKE SYSTEM			
INSPECTION.....	13-5		
		BRAKE FLUID	
		REPLACEMENT/AIR-BLEED	13-6
		BRAKE CALIPER	13-7
		BRAKE DISC	13-8
		BRAKE MASTER CYLINDER.....	13-8
		DRUM BRAKE-DRUM	13-11
		BRAKE LING	13-11
		BRAKE PANEL.....	13-12

MECHANISM DIAGRAM
Front Disc Brake System

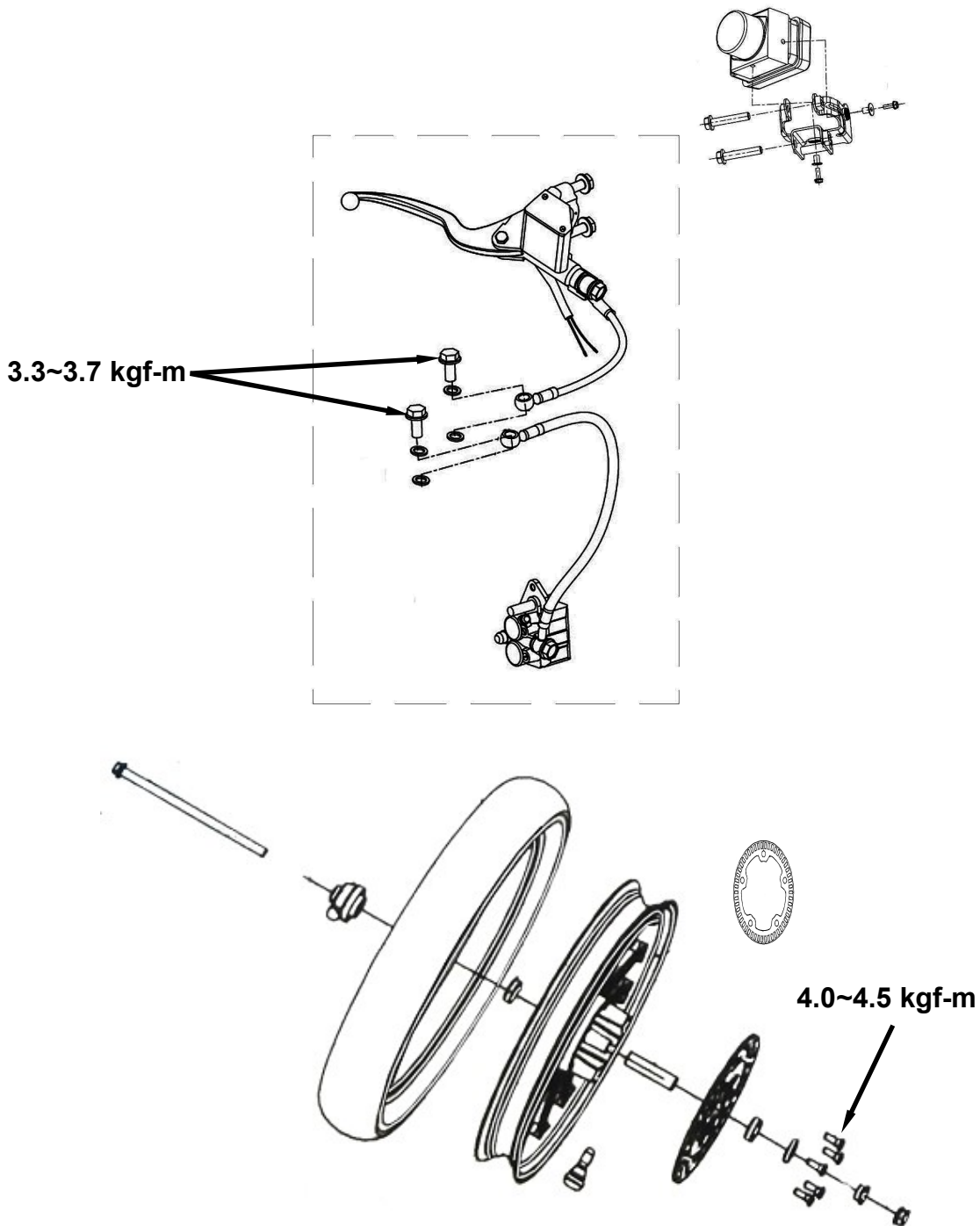

MECHANISM DIAGRAM
Rear Disc Brake System

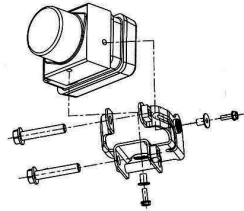

3.3~3.7 kgf-m

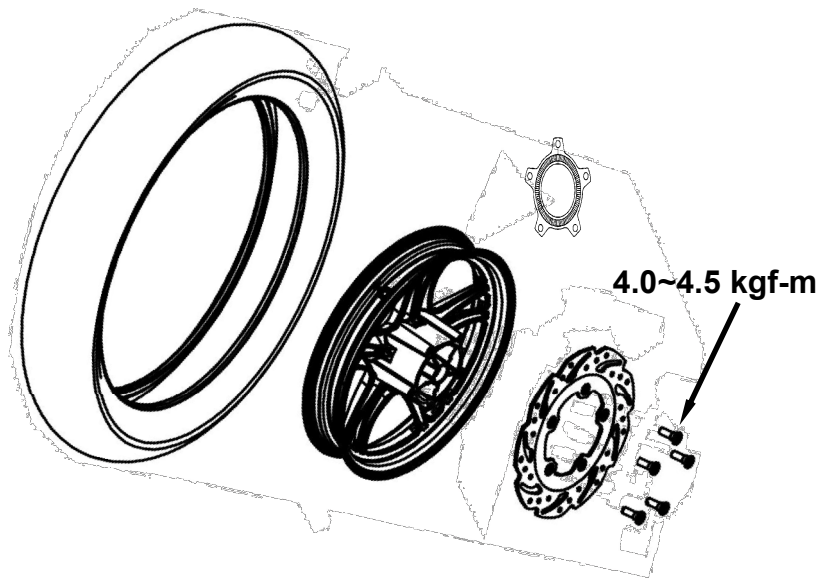
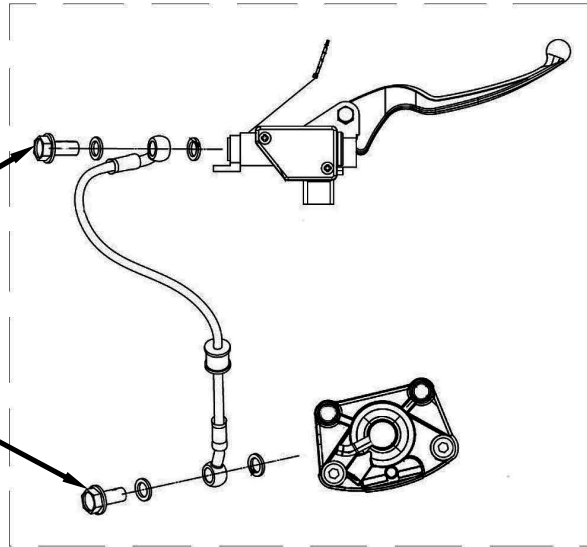

MAINTENANCE INFORMATION**Precautions in Operation****⚠ Caution**

Installing lining dusts may cause disorders of respiration system or cancer, therefore, never use air hose or dry brush to clean brake parts. Use vacuum cleaner or other authorized tool instead.

- The brake caliper can be removed without removing the hydraulic system.
- After the hydraulic system is removed, or the brake system is felt to be too soft, bleed the hydraulic system.
- While refilling brake fluid, care should be taken not to let the foreign material entering into the brake system.
- Do not spill brake fluid on the painted surfaces, plastic or rubber parts to avoid damage.
- Check the operation of the brake system before you go.

Specifications**Unit: mm**

Item	Standard	Limit
The thickness of front brake disc	3.50	2.00
The thickness of rear brake disc	3.50	2.00
Front brake disc eccentricity	0.15	0.30
Rear brake disc eccentricity	0.15	0.30
Master cylinder inner diameter	25.40	—
OD of front brake disc	260.00	—
OD of rear brake disc	240.00	—
Thickness of front disc brake lining	—	As brake ling mark
Thickness of rear brake lining	—	2mm or As brake ling mark

Torque values

Bolt for front brake lever	0.8~1.2kgf-m
Bolt for rear brake lever	0.8~1.2kgf-m
Brake hose bolt	3.3~3.7kgf-m
Bolt for brake caliper	3.1~3.5kgf-m
Air-bleed valve	0.8~1.0kgf-m

TROUBLE DIAGNOSIS**DISC BRAKE****Soft brake lever**

- Air inside the hydraulic system
- Hydraulic system leaking
- Worn master piston
- Worn brake pad
- Poor brake caliper
- Worn brake lining/disc
- Low brake fluid
- Blocked brake pipe
- Warp/bent brake disc
- Bent brake lever

Hard operation of brake lever

- Blocked brake system
- Poor brake caliper
- Blocked brake pipe
- Seized/worn master cylinder piston
- Bent brake lever

Uneven brake

- Dirty brake lining/disc
- Poor wheel alignment
- Clogged brake hose
- Deformed or warped brake disc
- Restricted brake hose and fittings

Tight brake

- Dirty brake lining/disc
- Poor wheel alignment
- Deformed or warped brake disc

Brake noise

- Dirty lining
- Deformed brake disc
- Poor brake caliper installation
- Imbalance brake disc or wheel

HYDRAULIC BRAKE SYSTEM INSPECTION

Inspection

Visual inspect for brake fluid leaking or damage. Check if brake hose connection loosen with wrench and turn the handlebar from right to left motion or press down the shock absorber to check if there is something is interfered with the brake system or brake components.

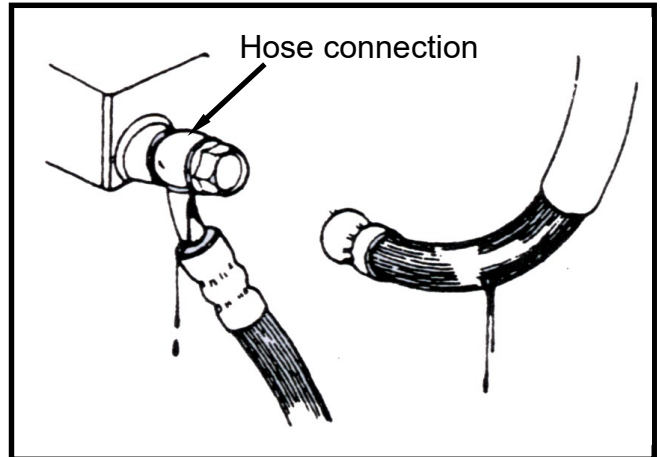

Operate the brake system and check the brake lining. Check the front brake from front side, and replace the brake lining with new one when the brake lining wear limitation groove reaches to the brake disc.

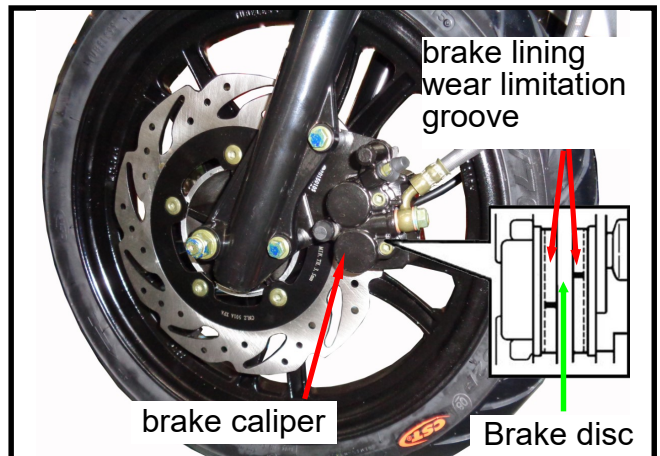

Park the motorcycle on a flat ground and check its brake fluid level. Recommended brake fluid: WELLRUN DOT 3 brake fluid

CAUTION

- The fluid level will not be correct if parking the motorcycle in title or just parking. It has to waiting for around 3~5 minutes.
- Never use faked brake fluid to prevent from chemical reaction.
- It has to apply with same brand brake fluid to sure the brake performance.

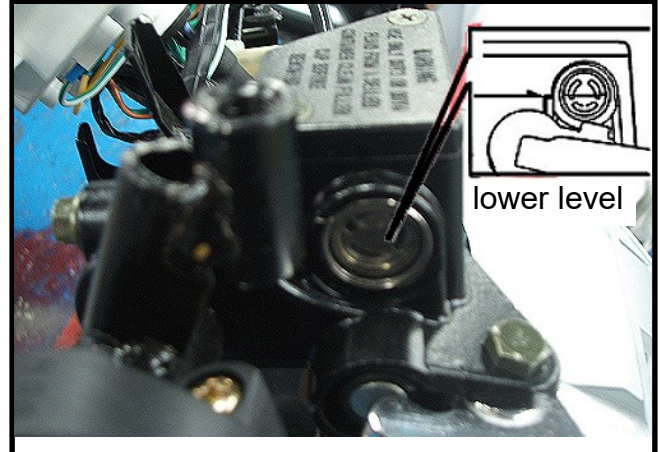

Brake Fluid Add

Turn the handlebar to let the master cylinder in horizontal position before removed the master cylinder cap. Place a rag onto painting, plastic or rubber components when conduct brake system maintenance.

CAUTION

- Do not over the upper level when adding brake fluid and avoid to spilling brake fluid on painted surfaces, plastic or rubber components to result in their damages.

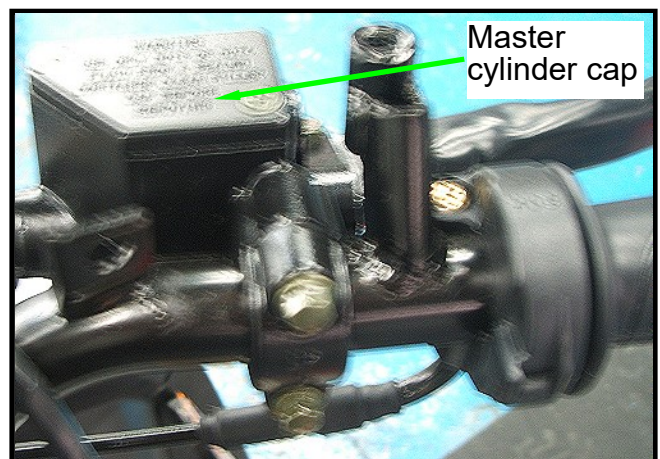

13. BRAKE

SYM

Remove the master cylinder cap and diaphragm.

Add good quality brake fluid and it has to add same brand brake fluid into the master cylinder. Clean dirty brake disc.

⚠ CAUTION

The dirty brake lining or disc will reduce the brake performance. The mixed non-compatible brake fluid will reduce brake performance. Foreign materials will block the system causing brake performance to be reduced or totally lost.

BRAKE FLUID REPLACEMENT/ AIR-BLEED

Connect drain hose to drain valve. Open the drain valve on the caliper and hold and release the brake lever alternatively until the old brake fluid is entirely drained out. Close the drain valve and add specified brake fluid into the brake master cylinder.

⚠ CAUTION

To reuse the spent brake fluid will effect brake performance.

Connect one end of transparent hose to the drain valve, and put the other end into a container.

Open the drain valve around 1/4 turns, and at the same time hold the brake lever until there is no air bubble in the drain hose and also feeling resistance on the brake lever.

Close the drain valve when finishing the brake system refilling fluid procedure, and operate the brake lever to check whether air bubble is in brake system or not. If brake is still soft, please bleed the system as described below.

1. Tightly hold the brake lever and open the drain valve around 1/4 turns, and then close the valve.

⚠ CAUTION

- Do not release the brake lever before the drain valve is closed.
- Always check the brake fluid level when carrying out the air bleeding procedure to avoid air entering into the system.

2. Slowly release the brake lever, and wait for a few seconds until it reaches its top position.

3. Repeat the steps 1 and 2 until there is no air bubble at the end of the hose. Tightly close the drain valve.

4. Make sure the brake fluid is in the UPPER level of the master cylinder, and refill the fluid if necessary.

5. Cover the cap.

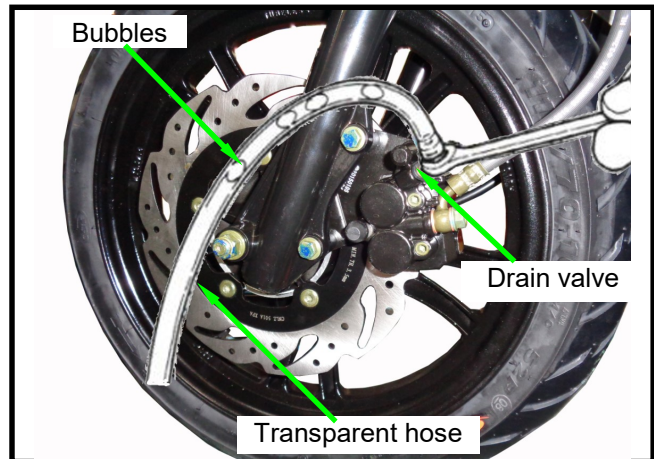
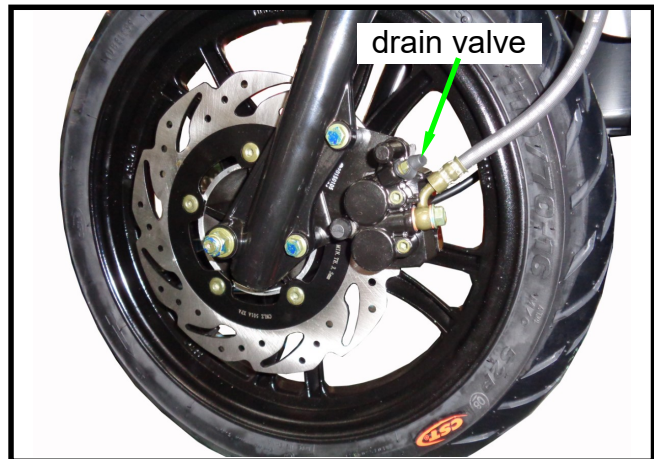
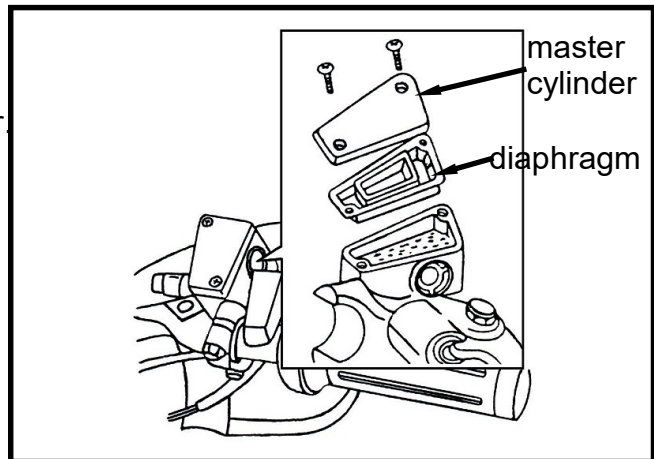

BRAKE CALIPER

Removal

Place a container under the brake caliper, and loosen the brake hose bolt and finally remove the brake hoses.

CAUTION

- Do not spill brake fluid on painted surfaces.

Remove two caliper bolts and the caliper.

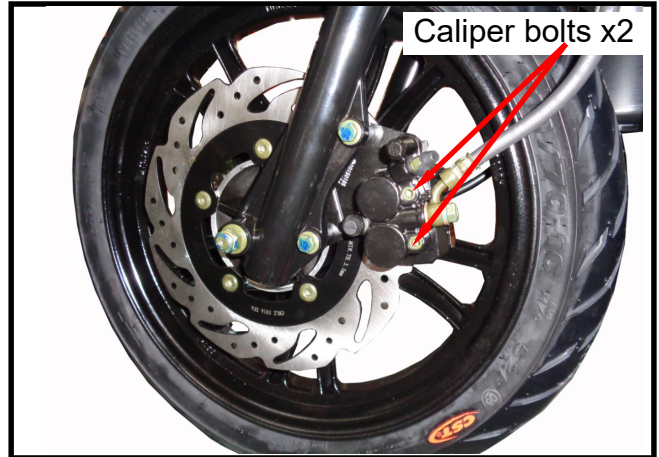

Make sure the brake lining condition. Replace the lining if the brake lining wear limitation groove close to the brake disc.

Brake Lining Replacement

Compress the caliper and let the brake lining out of the caliper mounting plate. Compress the brake lining locking spring. Remove the inner brake lining firstly and then remove the outer brake lining.

Compress the brake caliper at first as installation. Install the inner brake lining firstly, and then install the outer brake lining.

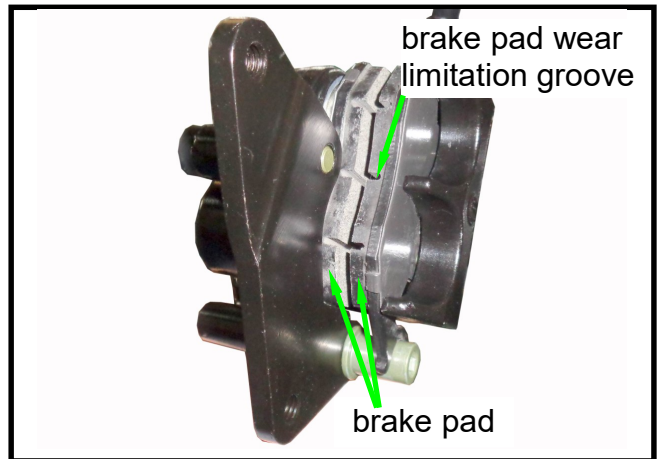

INSTALLATION

Install the brake caliper and tighten the attaching bolts securely.

Torque: 3.3 kgf-m

CAUTION

- Use M8 x 35 mm flange bolt only.
- Long bolt will impair the operation of brake disc.

Tighten the lining guide bolt.

Torque: 1.8 kgf-m

Use two seal washers and hose bolts to lock the hose and brake caliper in place.

Torque: 3.5 kgf-m

Refill up the brake fluid to the reservoir and make necessary air bleeding.

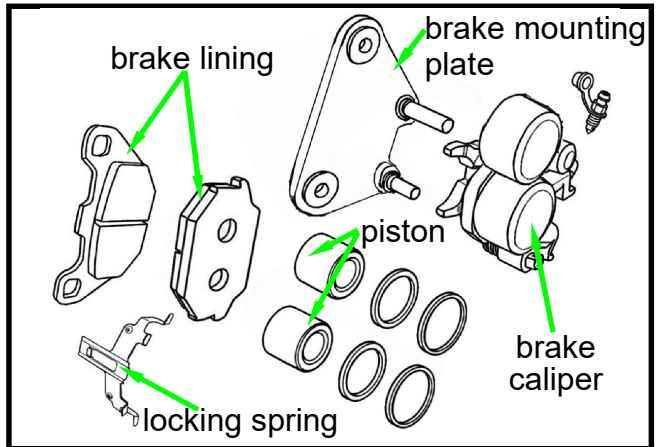

13. BRAKE

SYM

Rear Brake Caliper

Removal

Place a container under the brake caliper, and loosen the brake hose bolt and finally remove the brake hose.

⚠ Caution

- Do not spill brake fluid on painted surfaces.

Remove two caliper mounting bolts and the caliper.

Installation

Install the brake caliper and tighten the mounting bolts.

Torque: 2.9~3.5kgf-m

⚠ Caution

- Use M8 x 35 mm flange bolt only.
- Long bolt will impair the operation of brake disk.

Use two seal washers and hose bolts to lock the hoses and brake caliper in place.

Torque: 3.0~4.0kgf-m

Refill up the brake fluid to the reservoir and make necessary air bleeding.

Brake pad replacement

Remove the brake caliper upper parts (2 socket bolts).

Take out the brake pads.

Install the new brake pads onto brake caliper bracket.

Install the brake caliper upper parts and tighten the socket bolts.

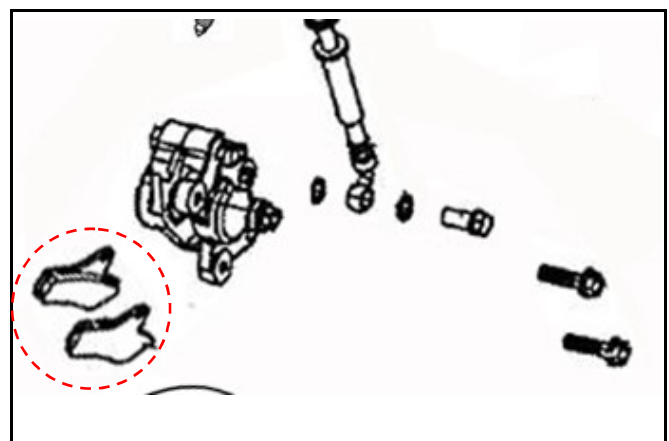
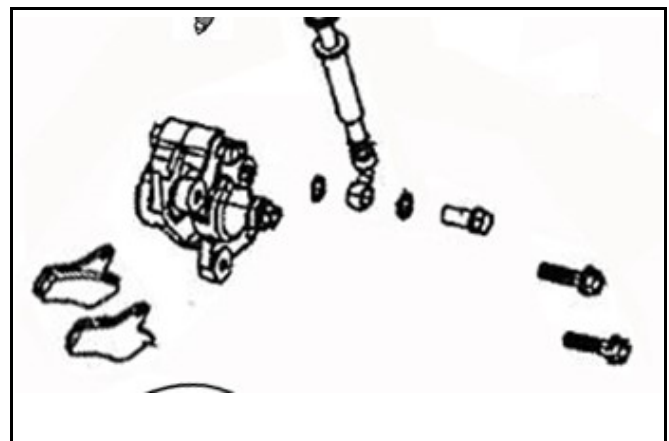
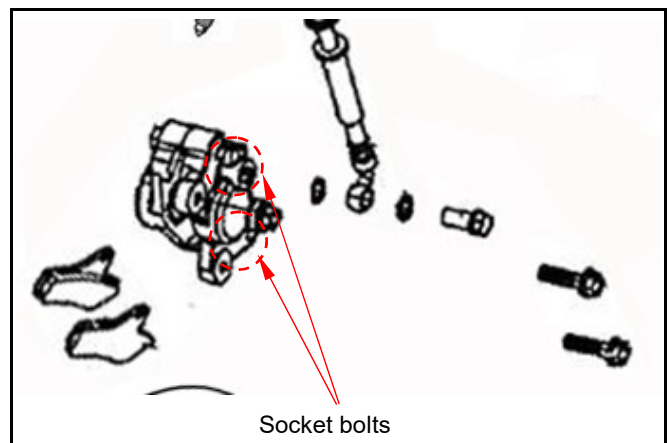
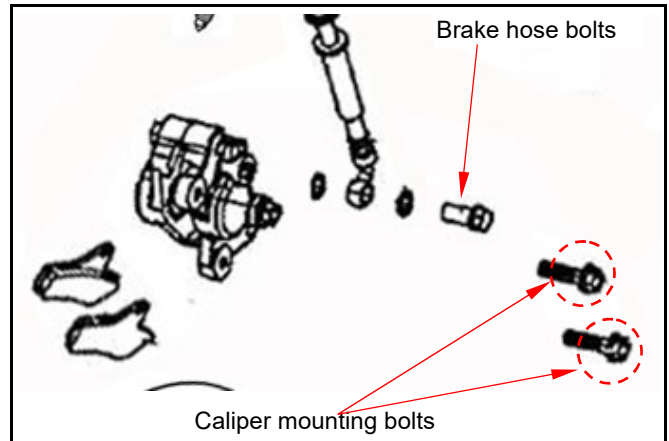

BRAKE DISC

Inspection

Visually check the brake disc for wear or break.

Measure the thickness of the disc at several places. Replace the disc if it has exceeded the service limit.

Allowable limit: 2.0 mm

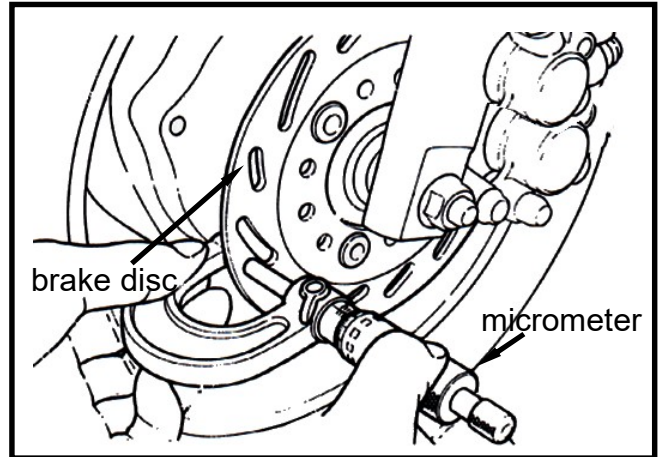

Remove the brake disc from wheel. Check the disc for deformation and bend.

Allowable limit: 0.30 mm

CAUTION

- Do not let grease touch to the brake disc that will cause brake performance.
- Do not clean the brake lining with air gun. Operator should wear mask & glove and use vacuum cleaner to clean the brake lining.

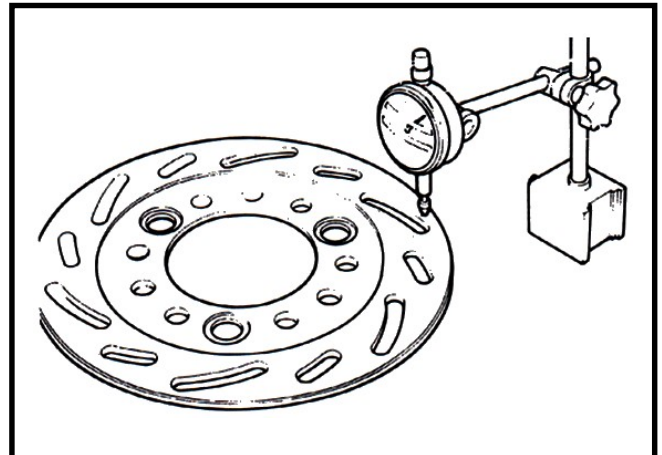

BRAKE MASTER CYLINDER

Removal

CAUTION

Do not let foreign materials enter into the cylinder.

CAUTION

The whole set of master cylinder, piston, spring, diaphragm and circlip should be replaced after removal.

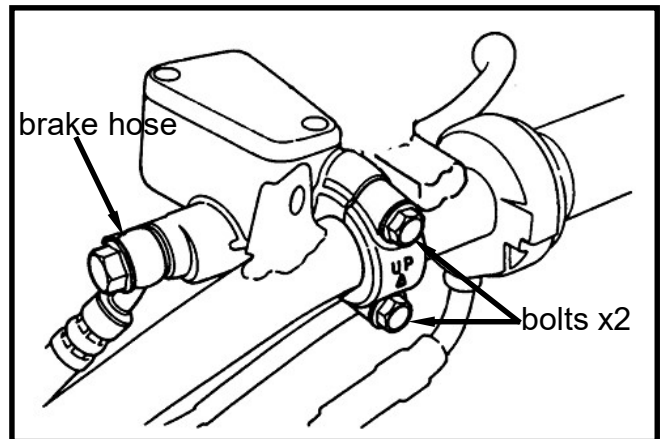

- Remove the front and rear handlebar guards.
- Remove the leads of brake lamp switch.
- Drain out the brake fluid.
- Remove the brake lever from the brake master cylinder.
- Remove the brake hose.
- Remove the master cylinder seat and the master cylinder.
- Remove the rubber pad.
- Remove the circlip.
- Remove the piston and the spring.
- Clean the master cylinder with recommended brake fluid.

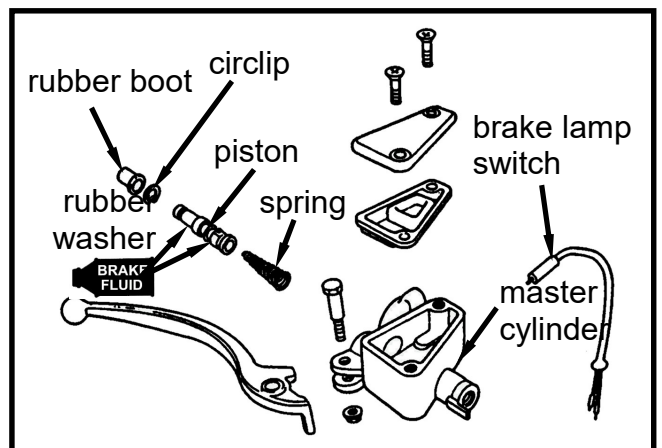

Inspection

Check the master cylinder for damage or scratch. Replace it if necessary.
 Measure the cylinder inner diameter at several points along both X and Y directions. Replace the cylinder if the measured values exceed allowable limit.

Allowable limit: 11.055 mm

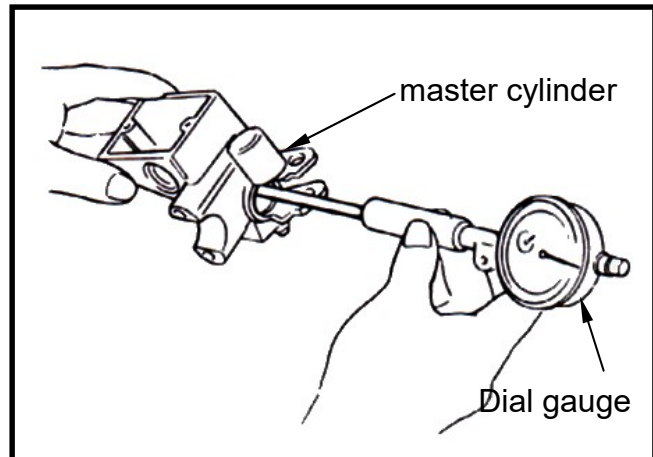

Measure the outer diameter of the piston. Replace the piston if its measured value exceeds allowable limit.

Allowable limit: 10.945 mm

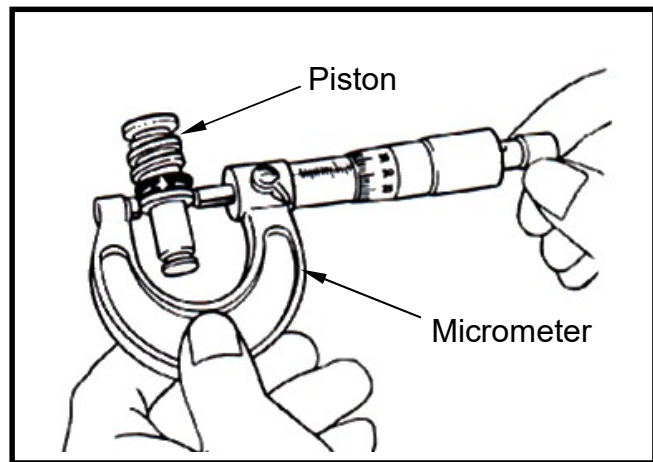

Assembly

⚠ CAUTION

- It is necessary to replace the whole set comprising piston, spring, piston cup, and circlip.
- Make sure there is no dust on all components before assembling.

Apply clean brake fluid to the piston cup, and then install the cup onto the piston. Install the larger end of the spring onto the master cylinder.

The master cup's cavity should be face inside of master cylinder when installing the master cup.

Install the circlip.

⚠ CAUTION

- Never install cup lip in the opposite direction.
- Make sure the circlip is seated securely in the groove.

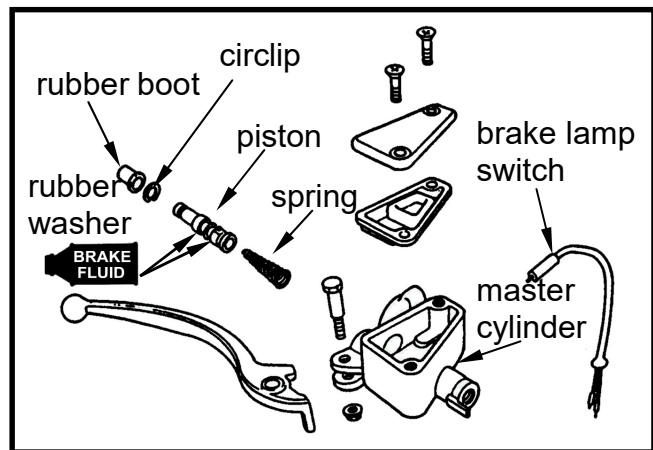

Install the rubber pad into groove properly.

INSTALLATION

Place the master cylinder onto handlebar, and install the split ring and bolts. The "UP" mark on the split ring should face upward.

Align the split ring on the master cylinder seat with the alignment point on the handlebar.

Tighten the upper bolt of the seat to specified torque value, and then tighten lower bolt to the same specified torque value.

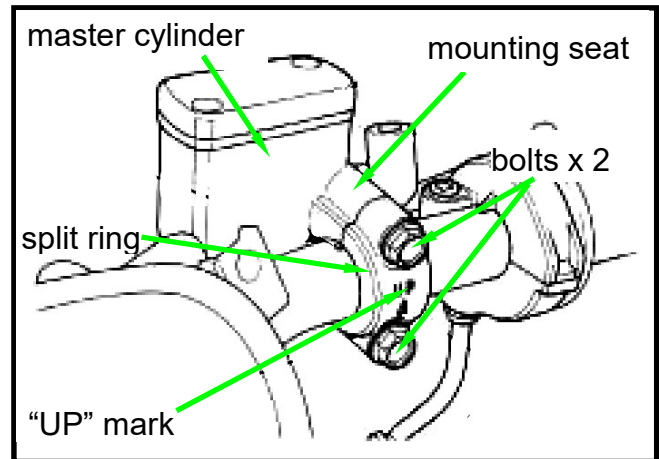

Install the brake lever, and connect leads to brake lamp switch.

Connect brake hoses with 2 new washes. Tighten the brake hose bolt to the specified torque value.

Torque value: 3.5 kgf-m

Make sure the hose is installed correctly.

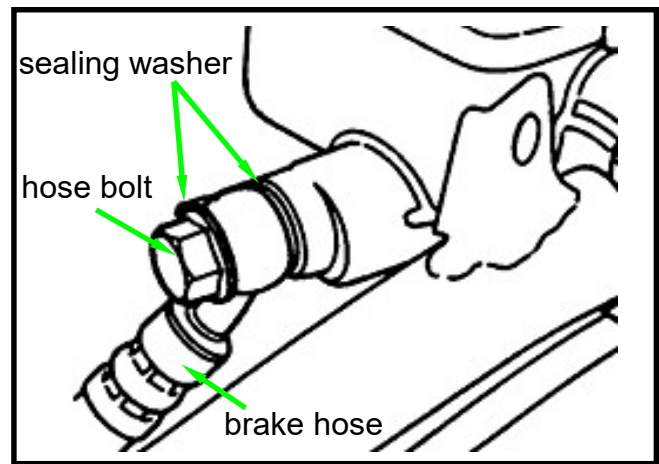

ABS (Anti-lock Brake System)

ABS is designed to help prevent the wheel from locking up when hard brakes are applied while running straight. The ABS automatically regulates the brake force. Intermittently gaining gripping force and braking force helps prevent wheel lock-up and allows stable steering control while stopping. Brake control function is identical to that of a conventional scooter. The right brake lever is used for the front brake and the left brake lever for the rear brake.

Use of non-recommended tires may cause malfunctioning of ABS and can lead to extended braking distance. The rider could have an accident as a result. Always use recommended standard tires for this scooter.

When the ABS is functioning, rider may feel a pulsing in the brake lever. This is normal. ABS does not function at the speed of approx. 5 km/h or below. ABS does not function if the battery is discharged.



Single channel style (BOSCH)



double channel style (CONTI)

Single channel style (BOSCH)

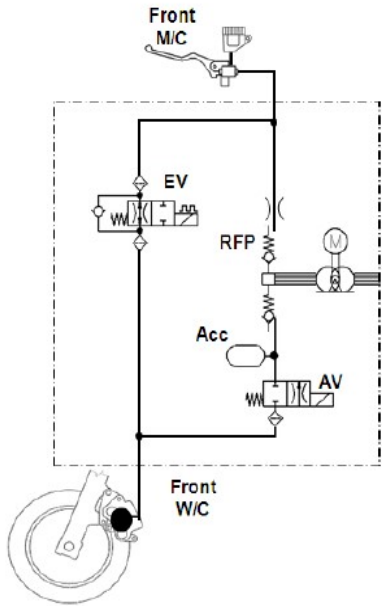

Front wheel oil pressure circuit diagram

Single channel ABS only controls the front wheels, and the rear brakes are non ABS

Configuration diagram of single channel ABS

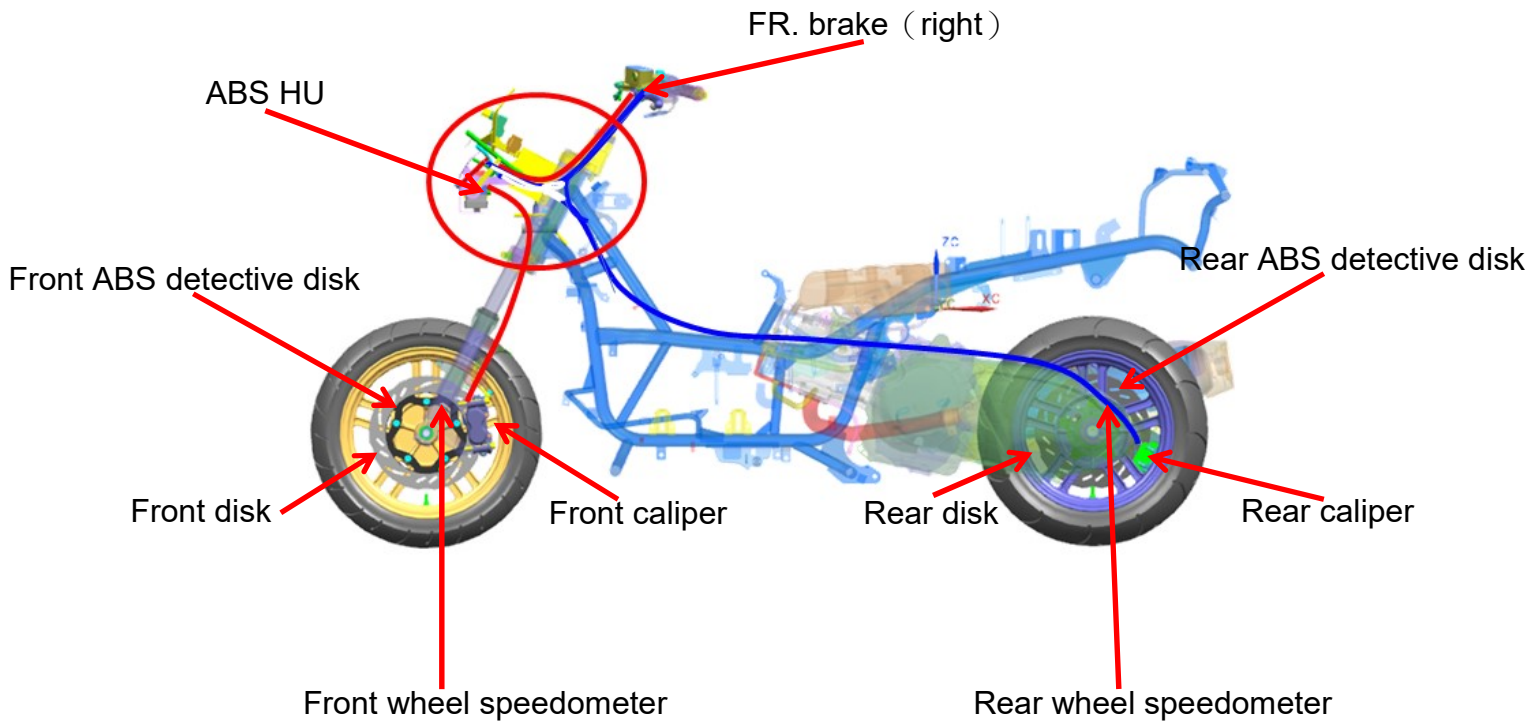

Single channel ABS rear brake system fails to pass HU

Double channel style (CONTI)

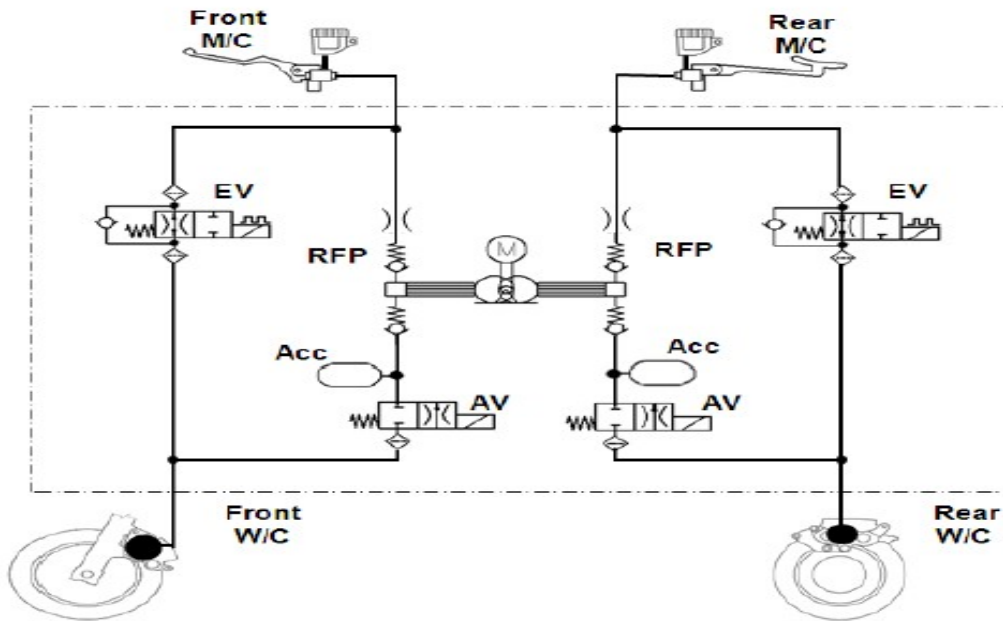

Front wheel oil pressure circuit diagram

Rear wheel oil pressure circuit diagram

Configuration diagram of double channel ABS

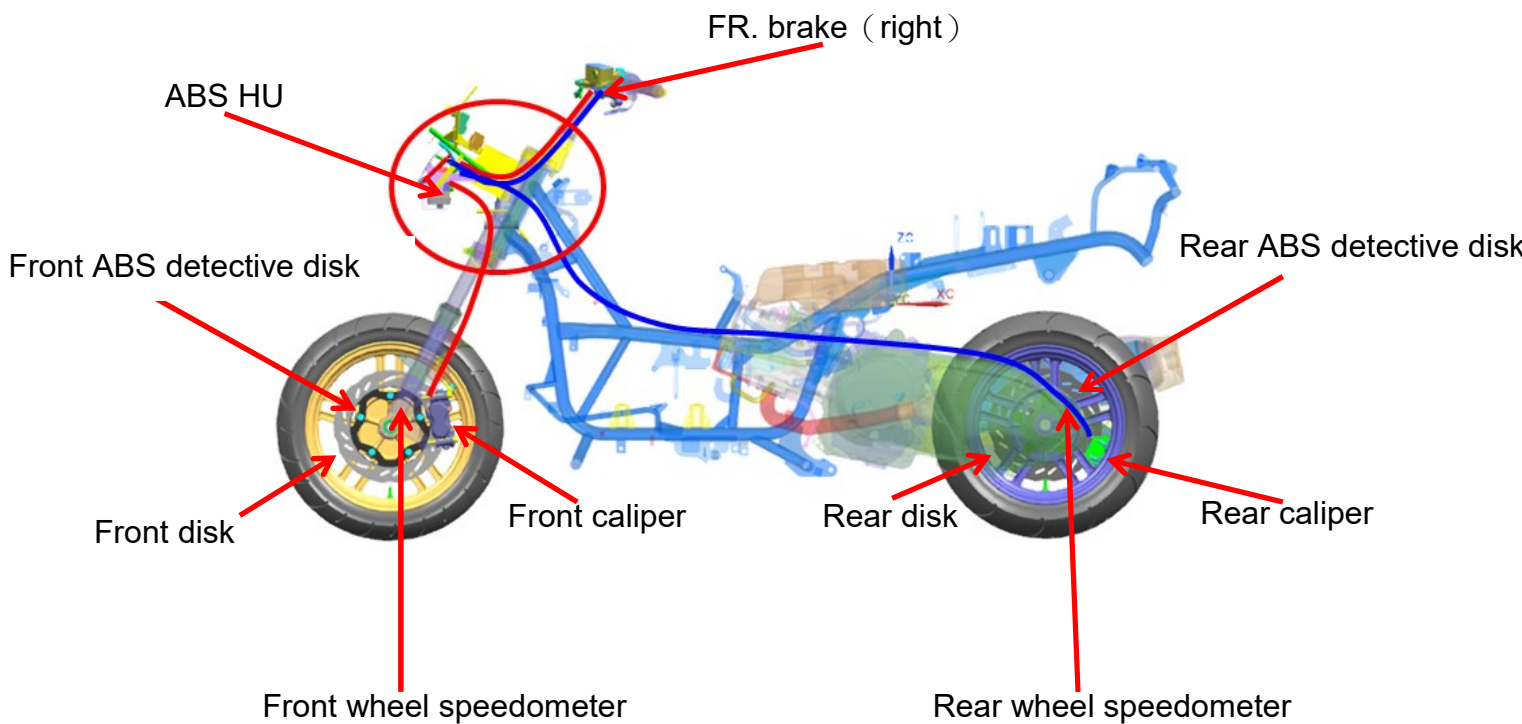

Dual channel ABS front and rear brake system passes HU

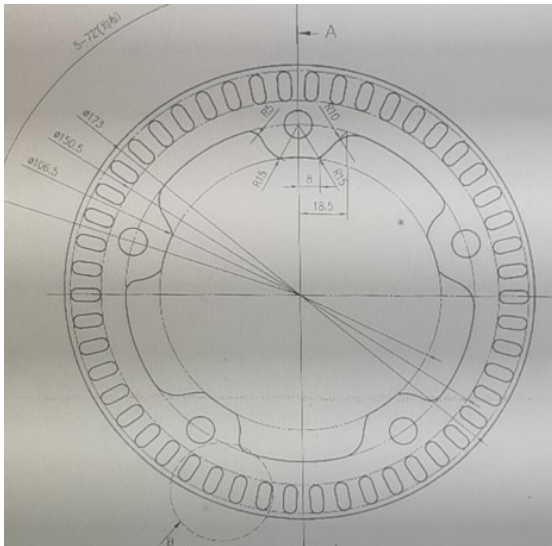

Front ABS detective disk

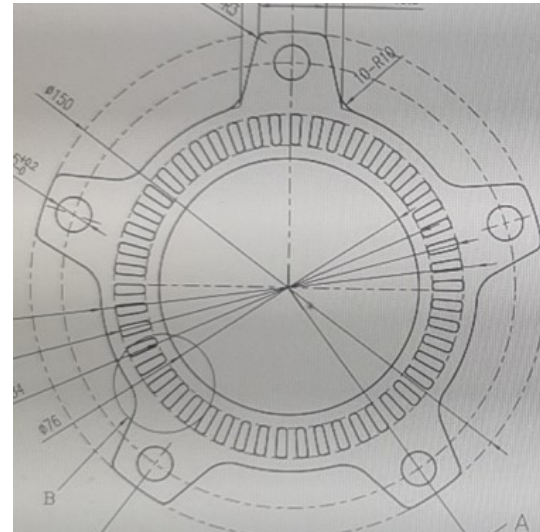

Rear ABS detective disk

Single channel style (BOSCH)

45120-XMC-0001 (50 holes)

43120-XJE-0001 (50 holes)

Double channel style (CONTI)

45120-X93-0000 (48 holes)

43120-ZBC-0001 (48 holes)

ABS trouble code

Fault code	NG code	Problem point
C1043	5043	Front wheel speed sensor Disconnection/gnd Short/Uz Short
C1042	5042	Front wheel speed sensor malfunction -Plausibility
C1045	5045	Rear wheel speed sensor Disconnection/gnd Short/Uz Short
C1044	5044	Rear wheel speed sensor malfunction- Plausibility
C1025	5025	Deviation between Wheel speed(WSS_GENERIC)
C1017	5017	Front Inlet Valve malfunction (EV)
C1018	5018	Front Outlet Value malfunction(AV)
C1013	5013	Rear Inlet Value malfunction(EV)
C1014	5014	Rear Outlet Value malfunction(AV)
C1035	5035	Pump Motor Malfunction
C1019	5019	Value Relay malfunction(Failsafe relay)
C1055	5055	ECU malfunction
C1052	5052	Power Supply Malfunction(Low Voltage)
C1053	5053	Power Supply Malfunction(High Voltage)

NOTE:

MECHANISM DIAGRAM	14-1	FRONT WHEEL	14-4
PRECAUTIONS IN OPERATION	14-2	FRONT SHOCK ABSORBER	14-9
TROUBLE DIAGNOSIS.....	14-2	FRONT FORK/STEERING COLUMN	14-9
STEERING HANDLE.....	14-3		

MECHANISM DIAGRAM

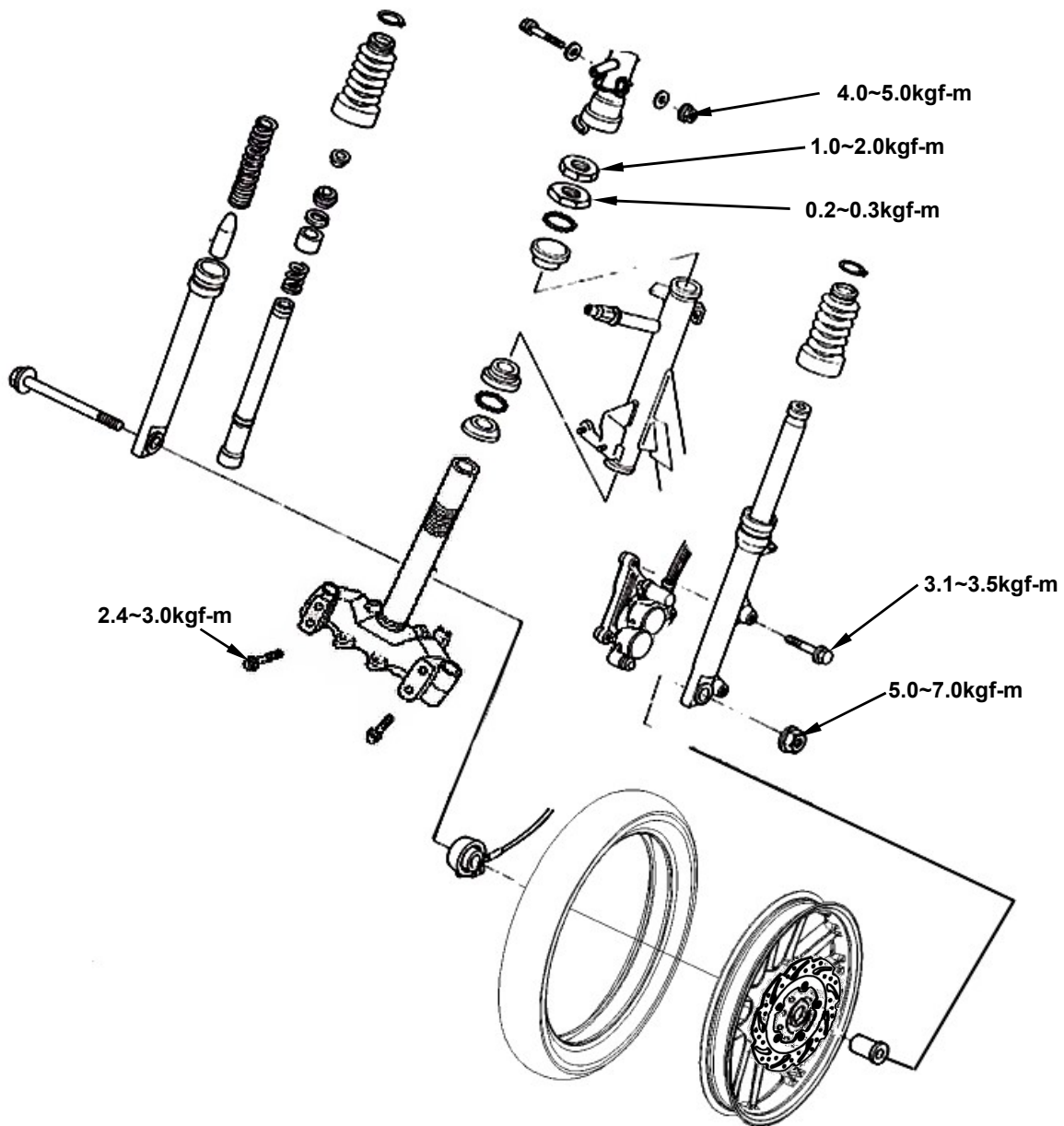

PRECAUTIONS IN OPERATION**General Information**

- Before remove front wheel, use a jack to lift the body until front wheel free of ground, and take care not to rotate body in reverse.
- Be careful not to allow oil or grease get on brake drum or linings.

Torque values

Front wheel axle	5.0~7.0kgf-m
Steering handlebar nut	4.0~5.0kgf-m
Steering column top cone sliding ring	0.2~0.3kgf-m
Steering column lock nut	1.0~2.0kgf-m
Speedometer cable nut	0.15~0.3kgf-m
Front shock absorber: Upper nut	2.4~3.0kgf-m

Tools**Special service tools**

- Steering column wrench
- Bearing remover
- Inner type bearing remover
- Attachment, 32×35 mm
- Attachment, 42×47 mm
- Steering column nut wrench
- Steering column top cone ring nut wrench

TROUBLE DIAGNOSIS**Hard steering stem**

- Over tightening of steering stem lock nut
- Broken steering stem steel ball and cone bearing seat
- Insufficient tire pressure

Steering stem off center

- Uneven left/right cushion
- Bend fork
- Bent front wheel/tire offset

Front wheel wobbling

- Deformed rim
- Front wheel bearing loose
- Faulty tire
- Wheel axle nut tightened improperly

Soft front suspension

- Weak fork springs
- Oil leakage of the shock absorber seal

Front suspension noise

- Cushion cover friction noise
- Cushion bolts loose

STEERING HANDLE**REMOVAL**

Remove handle front & rear covers and the front cover (refer to chapter 12).

Disc Brake

Remove the 2 bolts of the brake master cylinder, and then take out the master cylinder and the split ring.

⚠ Caution

Do not operate the front brake lever to avoid to pressing out the brake lining when removing the master cylinder.

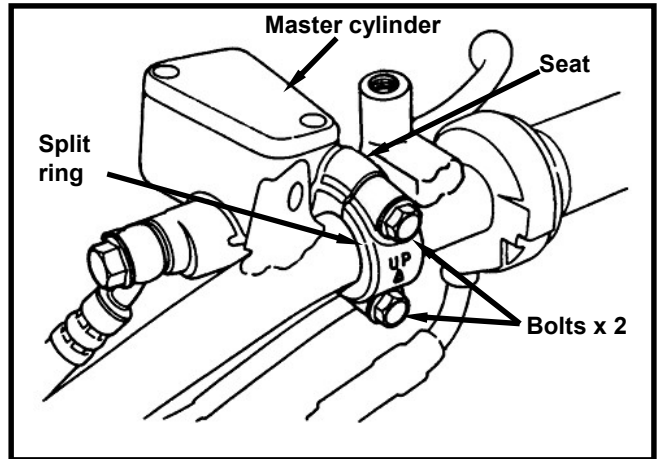

Remove acceleration handlebar screw and then remove the handlebar, acceleration cable, and handlebar cover & seat.

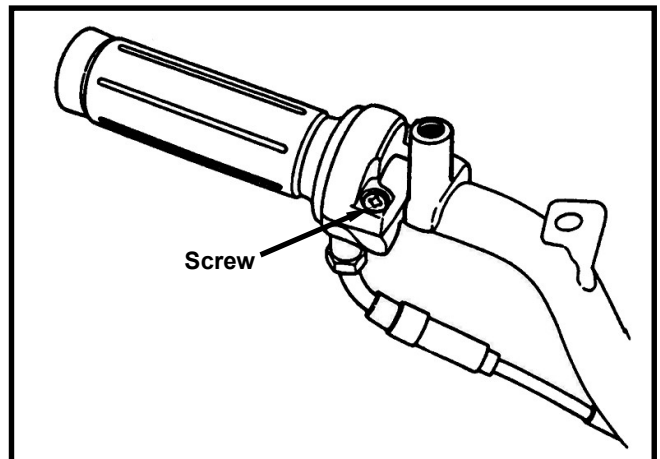

Remove the rear brake lever nut and screw, Remove the brake seat bolt, and then remove the seat.

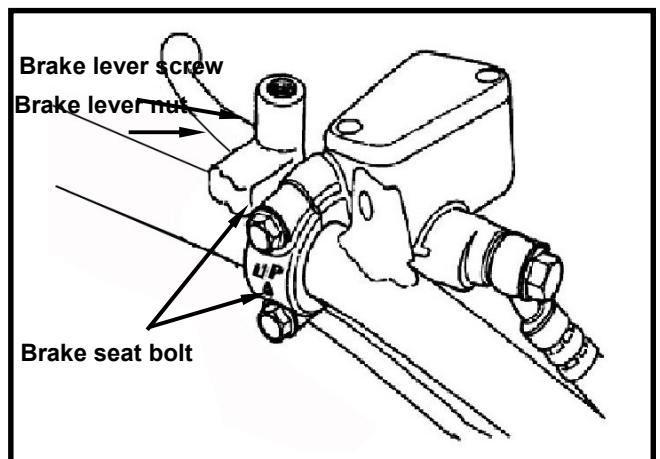

With a wrench to hold the handlebar bolt and then remove the nut.
Take out the handlebar after removed the bolt.

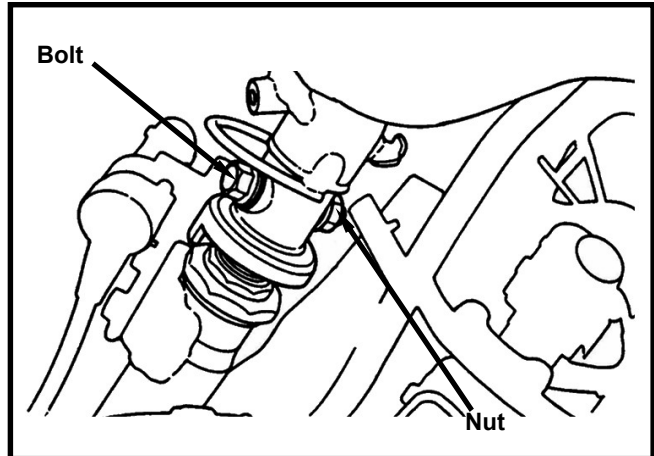

Installation

Install the handlebar according to the reverse procedure of removal.
Apply with some grease onto the handlebar moving parts when installing the acceleration handlebar seat, acceleration handlebar, and acceleration cable.

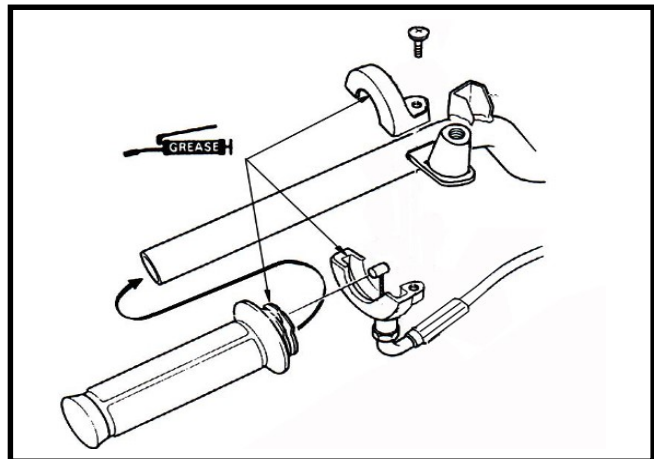

FRONT WHEEL

Removal

Disc Brake type

Support body bottom and lift front wheel free of ground.
Remove the bolts, and disconnect speedometer cable from the gear box.

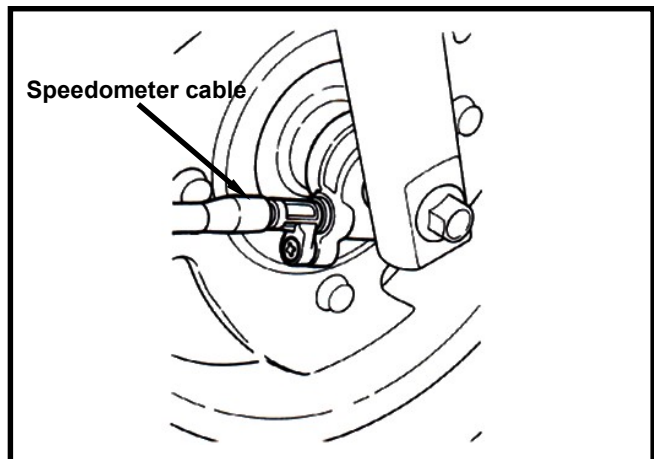

Remove the wheel axle nut and pull out the axle. Then, remove the front wheel.

⚠ Caution

Do not operate the front brake lever to avoid to pressing out the brake lining when removing the master cylinder.

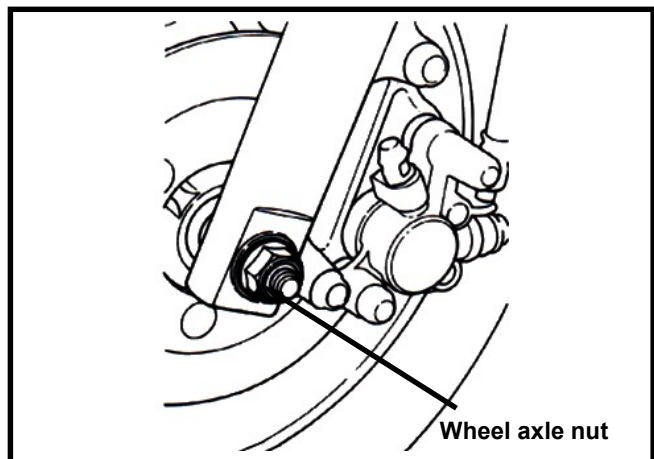

Inspection**Wheel axle**

Set the axle in V-blocks and measure the run-out.

Service limit: 0.2 mm.

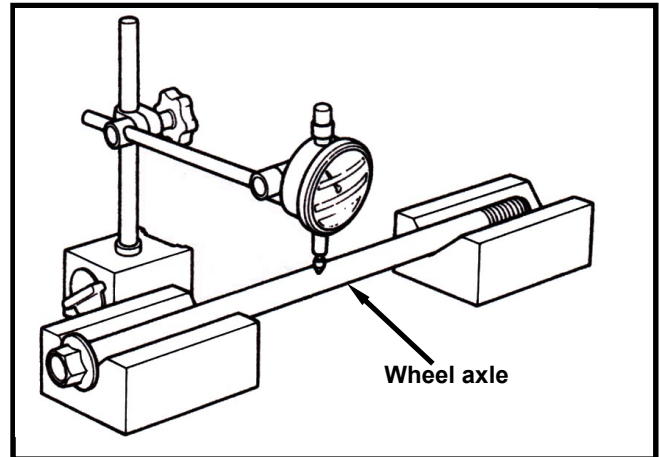
**Wheel Rim**

Place the wheel onto a rotated bracket.

Turn the wheel with hand and measure its wobble value with a dial gauge.

Service limit:

Radial : 2.0 mm

Axial : 2.0 mm

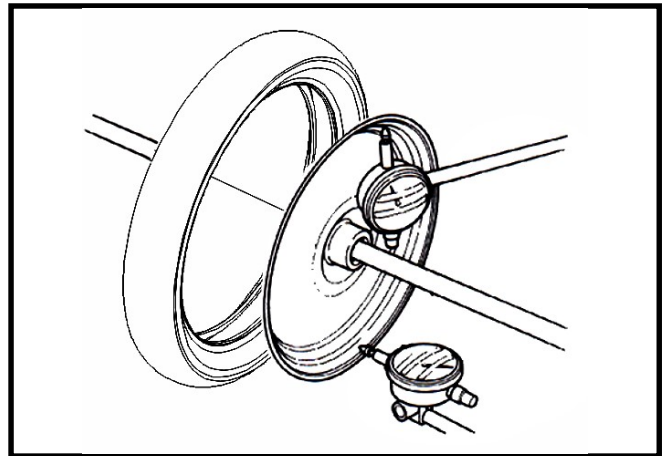
**Disassembly (Disc type)**

Remove 5 hex socket bolts and brake disc.



Remove the left axle ring and dust seal.
 Remove the dust seal on the right side of speedometer gear.
 Remove the bearing with the inner type bearing remover.
 Take out the bearing spacer and then remove the other bearing.

Tool:

Inner type bearing remover

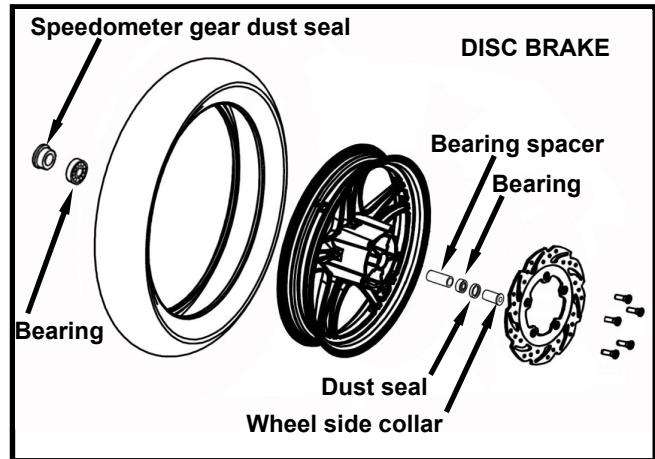

Bearing Inspection

Turn the inner race of bearing with fingers. The bearing should be turn smoothly. Also check if the outer collar is tightly connected to the wheel hub. If the bearing do not turn smoothly, or if they are too loose in the races, or damaged, then, remove and replace the bearings with new ones.

⚠ Caution

The bearing must be replaced in pair.

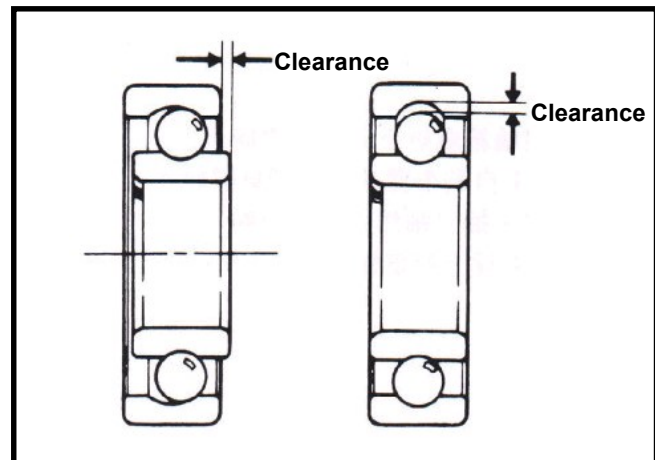

Installation

Install the bearing according to the reverse procedure of removal.
 Apply some grease into the bearing seat of the wheel hub.
 Install the left bearing onto the seat.
 Install the bearing spacer and then install the right bearing onto the seat.

⚠ Caution

- Do not install used bearing and replace the bearing once it has been removed.
- Do not the bearing in tile motion when installing.

Tool:

C-type compressor or bearing compressor.

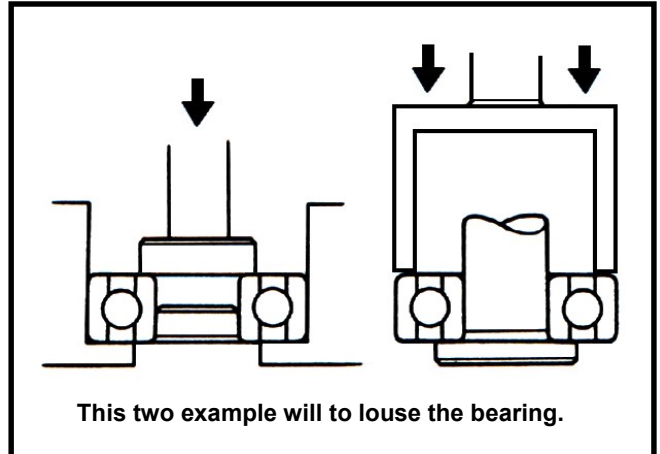

Disc Brake

Apply with some grease inside of the dust bearing.

Install the dust seal and the front wheel side collar.

Apply with some grease on both side of the speedometer gear oil seal, and then install the seal.

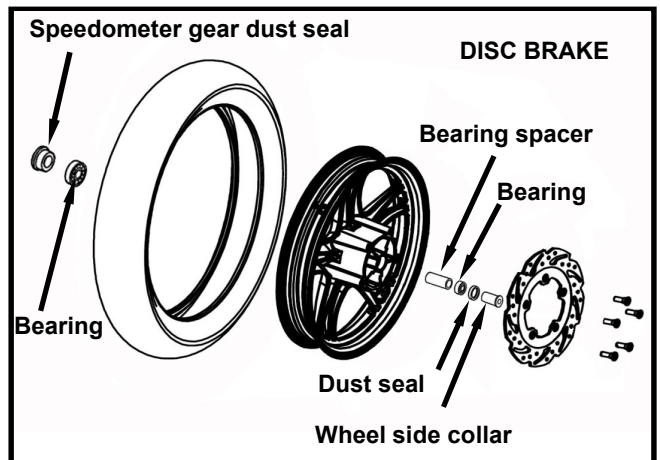

Align the flange part on the speedometer gear with the slot of wheel hub, and then install the brake disc (drum brake) or speedometer gear box.

⚠ Caution

Contaminated brake lining will reduce brake performance so the brake lining, brake drum and disc must be free of grease.

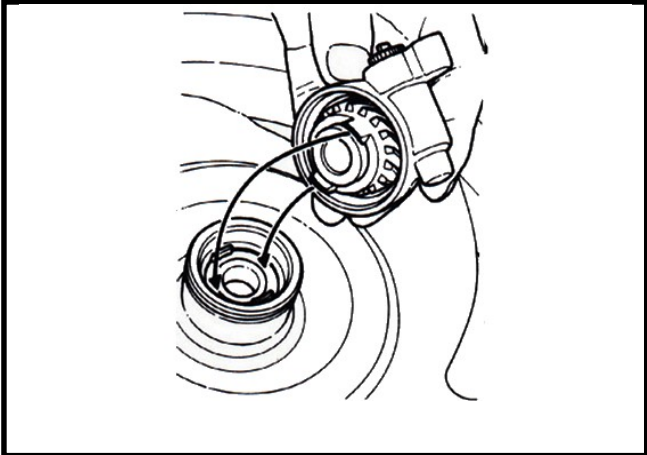

Place the front wheel between the front shock absorbers.

Disc Brake

Align the flange part on the speedometer gear with the slot of shock absorber stopper.

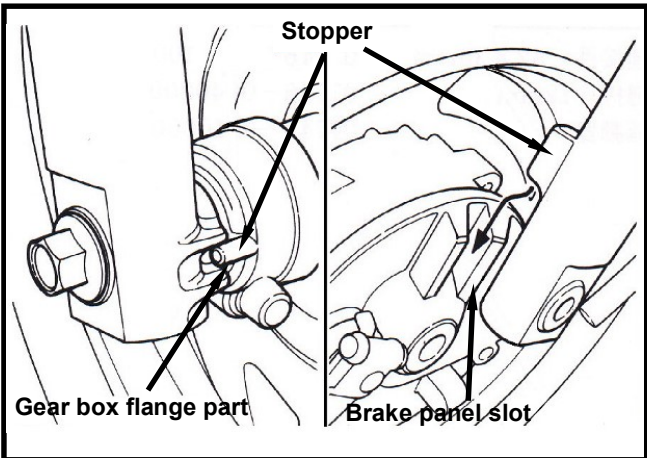

Disc Brake

Install the front wheel axle from right shock absorber side.

Install the wheel axle nut, and tighten it to specified torque value.

Torque value: 5.0~7.0kgf-m

Connect the speedometer cable to the speedometer gear box.

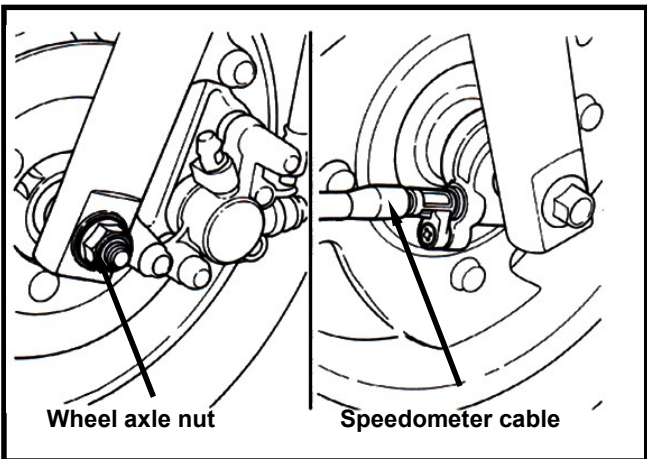

FRONT SHOCK ABSORBER**Removal**

Remove the front fender, front lower spoiler, front guard, and front wheel as well as front brake components.

Remove the brake fluid hose clipper or cable guide on the left shock absorber. (bolt x 1)

As for disc brake, remove the cable guide on the right shock absorber. (bolt x 1)

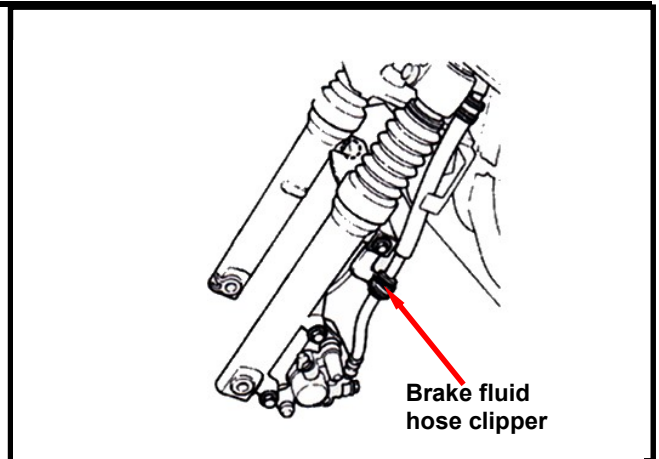

Remove the top connection bolt of the right shock absorber. (bolt x 4)

Remove the shock absorber from the front fork.

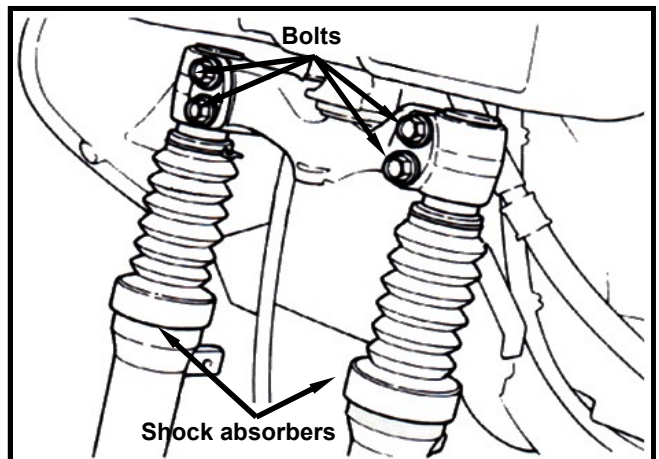
**Installation**

Install the shock absorbers according to the reverse procedure of removal.

Align the shock absorber top-edge with the top-end level of the front fork when installing the front shock absorber onto the front fork. Then, tighten the nut.

Torque value: 2.4~3.0kgf-m

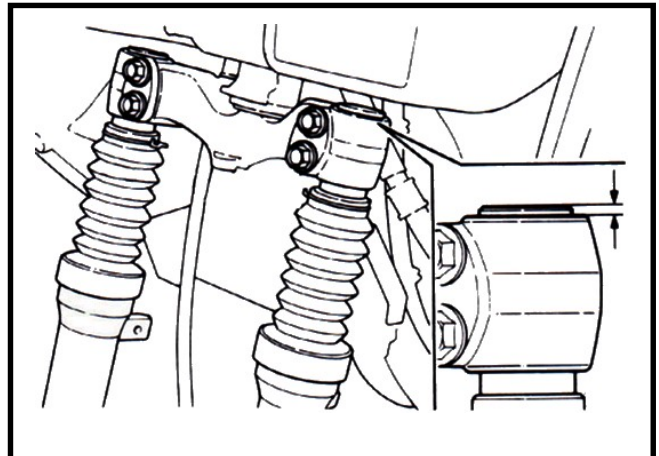
**FRONT FORK/STEERING COLUMN****Removal**

Firstly, remove the handlebar, front wheel, front brake set, and front shock absorbers.

Remove the steering column nut.

Remove the top cone ring, and then remove the steering column.

⚠ Caution

Place the steering column bearing balls into a parts container to avoid to missing or shortage.

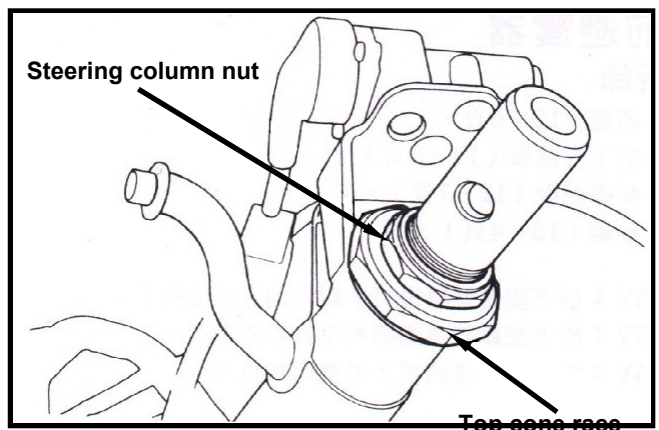

With a plastic hammer to tap the steering column slightly, and then remove the top ball bearing seat.

Remove the lower-end cone bearing seat on the frame with a punch.

⚠ Caution

Do not damage the frame and the steering column.

Installation

Install a new top-cone bearing seat onto the top of steering column.

And then, push the lower-cone bearing seat from bottom until to locking position.

⚠ Caution

Do not let the ball bearing in title motion as installation.

Apply with some grease onto the top & bottom bearing balls, and then install the balls into bearing seat.

Press in a new lower cone-race onto the steering column, and lubricate it with grease. Install the steering column.

Lubricate the top-cone race with grease.

Drive the cone-race into the steering column until contact with the top bearing seat no clearance. Note, return 1/2 turn and then tighten the top cone race to specified torque. (tighten the race around 1/4~3/8 turn more.)

Torque value: 0.2~0.3kgf-m

⚠ Caution

Do not tighten the top cone race too tight to prevent from damage the ball bearing seat when tightening the top cone race.

Install the steering column nut and lock the top cone race. Then, tighten the nut.

Torque value: 1.0~2.0kgf-m

Install the bearing seat according to the reverse procedure of removal.

⚠ Caution

Check the steering column if it can be turned freely and no clearance in vertical motion.

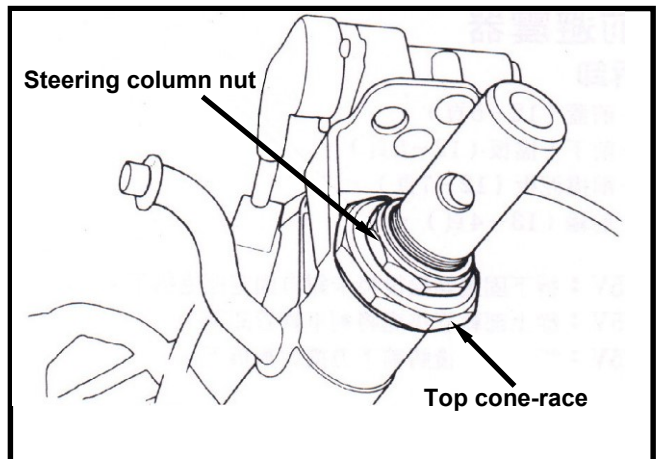
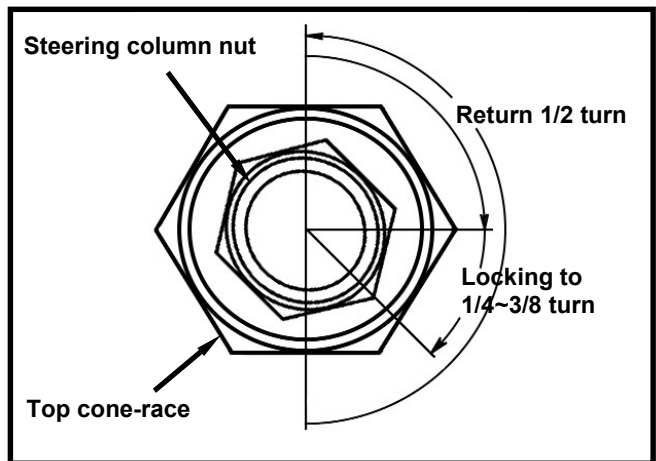
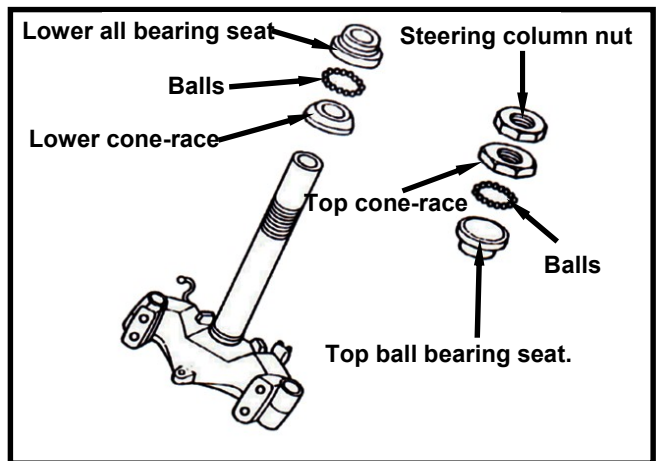
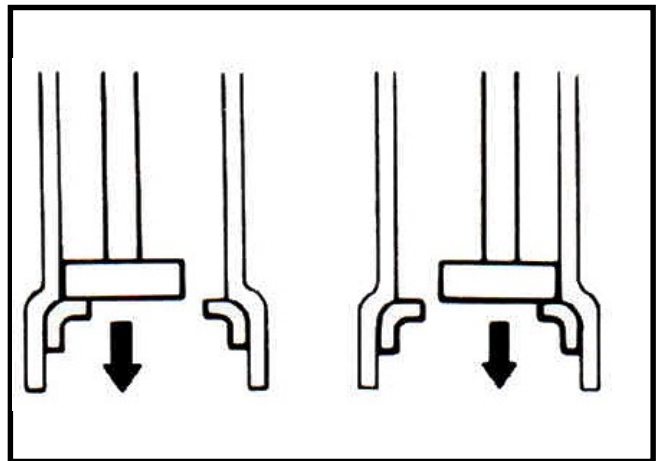

MECHANISM DIAGRAM.....	15-1	EXHAUST MUFFLER.....	15-3
PRECAUTIONS IN OPERATION.....	15-2	REAR WHEEL.....	15-3
TROUBLE DIAGNOSIS	15-2	REAR SHOCK ABSORBER.....	15-4

MECHANISM DIAGRAM

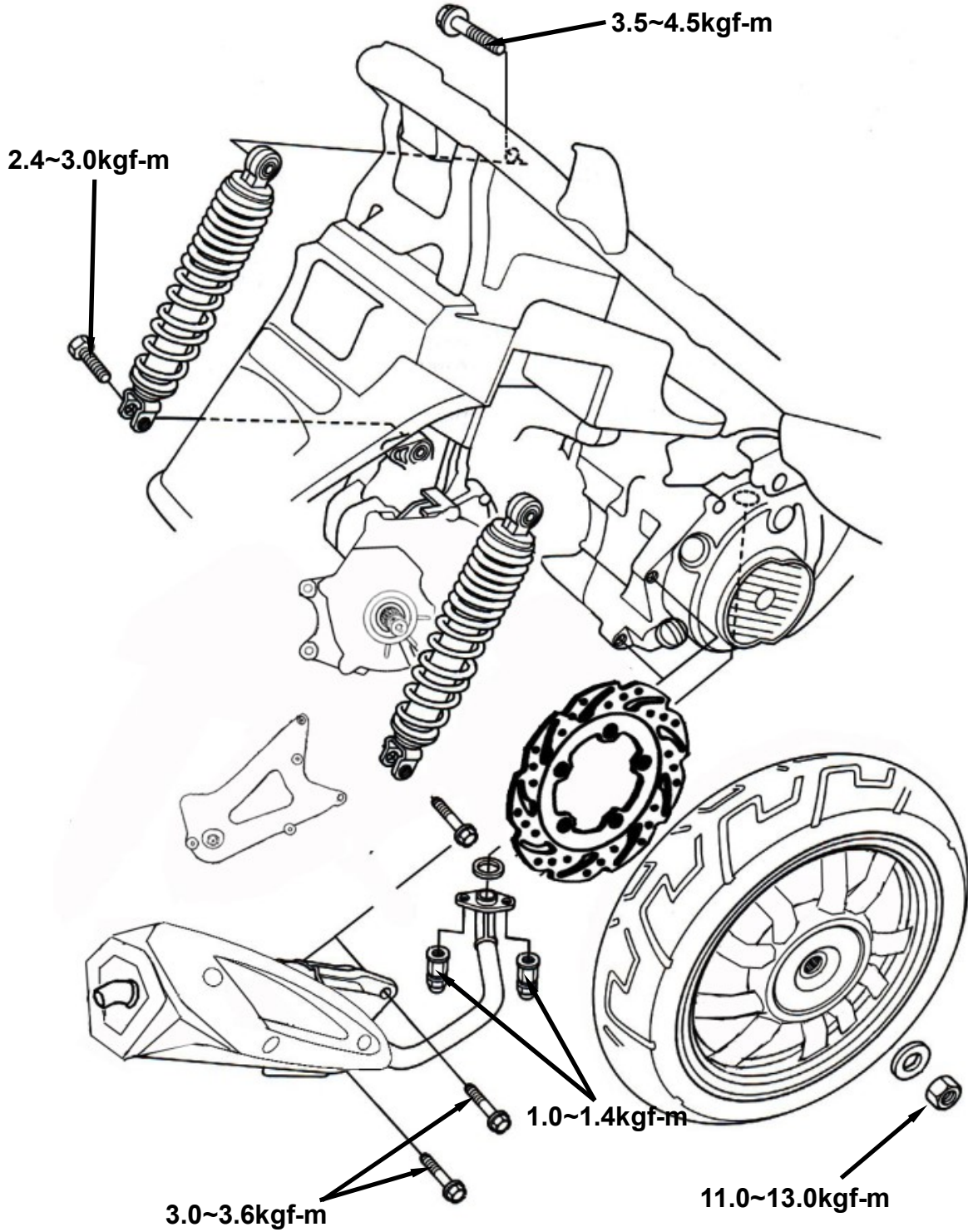

PRECAUTIONS IN OPERATION

General Information

As for the wheel removal, service, and installation procedures, please refer to the service manual of high speed tire.

Specification

Unit: mm

Items		Standard	Limit
Wheel wobbling	Radial	-	2.0
	Axial	-	2.0
Thickness of rear brake lining		4.0	2.0

Torque values:

Rear axle nut	11.0~13.0kgf-m
Rear shock absorber upper mount bolt	3.5~4.5kgf-m
Rear shock absorber lower mount bolt	2.4~3.0kgf-m
Exhaust muffler connection nut	1.0~1.4kgf-m
Exhaust muffler connection bolt	3.0~3.6kgf-m

TROUBLE DIAGNOSIS

Rear wheel wobbling

- bend wheel rim
- poor tire
- loosen wheel shaft

Shock absorber too soft

- insufficient shock absorber spring force

Braking Noise

- worn brake lining
- brake drum deformation
- improperly brake panel installation
- unparalleled brake drum or wheel unparallel.

Poor brake performance

- Poor brake adjustment
- contaminated brake lining
- worn brake lining
- greased brake drum
- contaminated and seized brake cable
- improperly installation of brake cable

EXHAUST MUFFLER**Removal**

Remove the front-end nut of the exhaust muffler. (nuts x 2)
 Remove the bolts. (bolts x 2)
 Remove the exhaust muffler.

Installation

Install the exhaust muffler according to the reverse procedure of removal.

⚠ Caution

Replace the exhaust muffler gasket if it is broken or deformed.

Torque value:

Exhaust muffler connection bolt:
 3.0~3.6kgf-m
 Exhaust muffler connection nut:
 1.0~1.4kgf-m

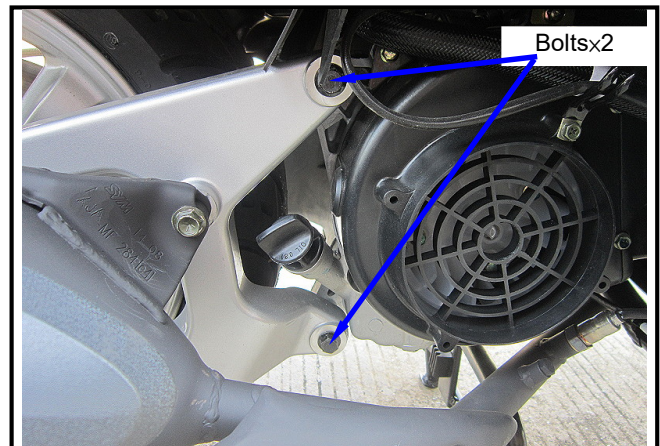
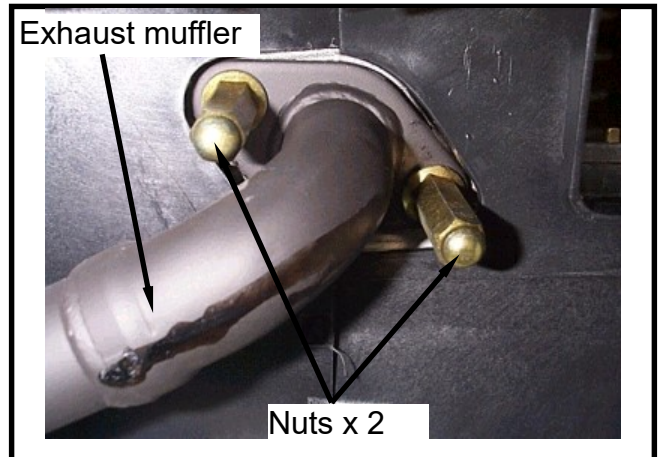
**REAR WHEEL****Inspection**

Measure wheel rim wobbling.

Service limit:

Radial: 2.0mm

Axial: 2.0mm

If the wheel rim wobbling out of the specification, except resulted from the wheel rim deformation, it might be loosen or worn final driving shaft bearing or bend, deformed driving shaft.

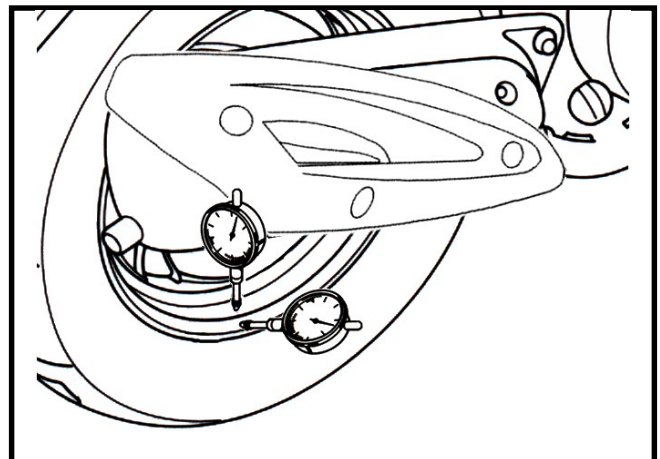
**Removal**

Remove the exhaust muffler . (bolts x 2)
 Remove the rear wheel. (wheel axle nut x1)

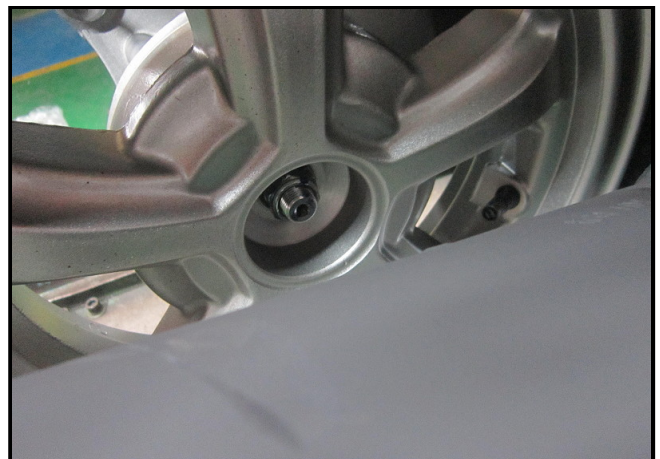

REAR SHOCK ABSORBER

Removal

- Remove the luggage box. (bolts x 6)
- Remove the rear carrier. (bolts x 3)
- Remove the left & right body covers. (screws x 4, bolts x 2)
- Remove the air cleaner bolts (bolts x2)
- Remove the lower nut of the rear shock absorber (bolt x 1)
- Remove the upper nut of the rear shock absorber (bolt x 1)
- Remove the rear shock absorber .



Installation

Install the rear shock absorber according to the reverse procedure of removal.

Caution

The rear shock absorber has to be replaced with one set and can not be replaced by unauthorized persons. Otherwise, it might damage the rubber bushing and construction.

Torque values

- Rear shock absorber lower mount bolt:
2.4~3.0 kgf-m
- Rear shock absorber upper mount bolt:
3.5~4.5 kgf-m

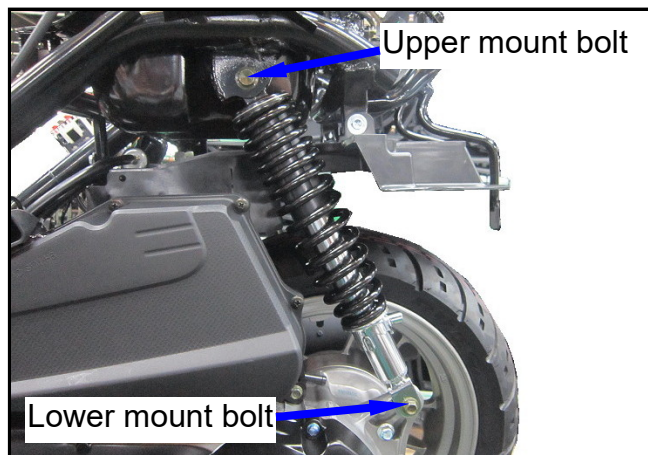

MECHANISM DIAGRAM	16-1	STARTING SYSTEM.....	16-14
PRECAUTIONS IN OPERATION	16-2	METER	16-15
TROUBLE DIAGNOSIS.....	16-4	LIGHTS/BULBS.....	16-17
CHARGING SYSTEM.....	16-5	SWITCH	16-19
IGNITION SYSTEM.....	16-11	FUEL UNIT	16-22

MECHANISM DIAGRAM

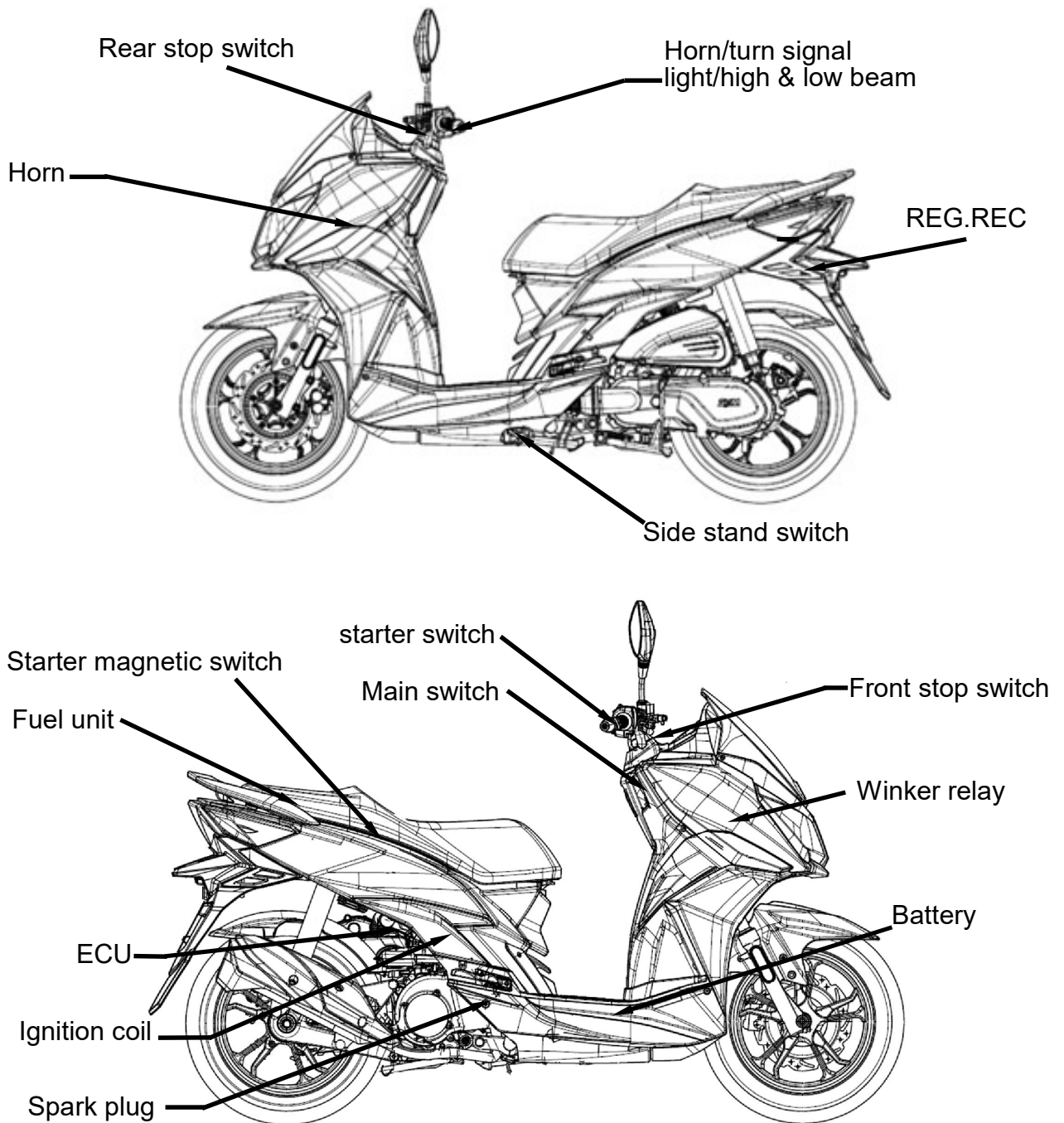

PRECAUTIONS IN OPERATION**Charging System**

- When remove the battery, the disconnection sequence of cable terminals shall be strictly observed. (First disconnect the negative cable terminal, next, the positive cable terminal.)
- MF (Maintenance Free) battery does not need to check, add electrolyte or distilled water.
- Battery must be taken out from scooter when charging the battery. But do not open the battery caps.
- Do not quick charge the battery unless in emergency.
- A voltmeter must be used when checking battery charging condition.
- Battery can be charged or discharged alternately. To set a discharged battery idle for a prolonged period will shorten its service life and reduce its capacity. Usually, battery's capacity will reduce after 1~2 years. After low capacity battery was charged, its voltage will increase. If it connects to an additional load, the voltage will reduce suddenly, and then go up again.
- Over-charged battery. Usually, the over-charged battery can be seen externally. If a short circuit occurred inside the battery, there will be no voltage on the terminals of battery if voltage regulator does not operate. Then, the battery's voltage will be too high that may reduce battery's life.
- The battery will be self-discharged if it was set idle for a long time. An idle battery must be charged about every 2months.
- A new battery filled with electrolyte will generate a voltage after filled out electrolyte. The voltage should be in 12.5V or more after 10 minutes. When electrolyte is not enough, the battery must be filled with electrolyte and then charged to prolong the battery's life-span.
- Please check electrical device according to the procedure of diagnosis chart.
- Do not disconnect and connect the connector of electrical devices when current is passing these devices because this will generate high voltage and the electrical components in the voltage-current regulator will be damaged. The ignition switch must be turned OFF before performing any work.
- Please do not replace with traditional type battery as replacement.
- Please refer to the removal instruction when removing the alternator and the pulse generator.

Ignition System

- Please follow the procedure of trouble diagnosis chart to check ignition system.
- The ignition system equipped with a auto-advanced timing device in CDI unit. Thus, ignition timing need not to be adjusted. In case of incorrect ignition timing occurred, check the CDI unit or alternator system. It has to check the ignition timing with the ignition timing light if replaced these components.
- Do not hang or impact the CDI unit of ignition system because the major faulty of CDI unit is caused by impact. Therefore, take care when disassembling.
- Most of ignition system problems were resulted from poor connecting connector. Please check the connectors first when servicing.
- Make sure that the heat range of spark plug is suitable. Improper spark plug is the main cause of poor engine operation or combustion.
- Inspection procedures in this manual are based on Max. voltage. This manual also contains methods of how to check ignition coil resistance and component operation.
- Please follow the continuity chart to check ignition switch.

Starting System

- Starting motor can be removed directly from engine.
- Please refer to chapter 10 for starting clutch removal procedures.

Specification**Charging System**

Items		Specification
Battery	Capacity/type	12V 6Ah
	Charging rate	STD:0.6A/5~10hrs, emergency charging: 6A/0.5hrs
	Voltage (20°C)	Full charged 13.1V Under charged 12.3V
Alternator	Capacity	12V / 6.2A
	Lighting coil resistance (20°C)	Between yellow-green: 0.8±0.1 Ω
	Charging coil resistance (20°C)	Between white-green: 0.6±0.1 Ω
Leaking current		Less 1mA
RPM for starting charging		1700rpm(headlight ON)
Voltage controlled by regulator		14.5±0.5 V
Resistor	Resistance (20°C) 5W5Ω	4.5~5.5Ω
	Resistance (20°C) 30W7.5Ω	7.0~8.0Ω

Ignition System

Item		Specification
Spark plug	Standard	NGK CR7HSA (Recommended usage)
	Hot type	NGK CR8HSA
	Cold type	NGK CR6HSA
	Spark plug gap	0.6~0.7 mm
Ignition coil resistance (20°C)	Primary	0.21±10%Ω
	Secondary	With plug cap : 7.6±10%KΩ Without plug cap : 3.1±10%KΩ
Ignition timing	"F" Mark	Before TDC 13° / 1700 rpm
	Timing advanced character	Before TDC 28° / 4000 rpm Before TDC 27° / 8000 rpm
Pulse generator resistance (20°C)		50~200Ω
Exciting coil resistance (20°C)		400~800Ω
Ignition coil-primary max. voltage		95~400 V
Pulse generator voltage		1.7 V above
Exciting coil voltage		95~400 V

Starting System

Item		Specification
Starting motor	type	DC TYPE
	capacity	0.5 KW

TROUBLE DIAGNOSIS

No voltage

- Battery discharged
- The cable disconnected
- The fuse is blown
- Improper operation of the main switch
- Low voltage
- The battery is not fully charged
- Poor contact
- Poor charging system
- Poor voltage regulator

No spark produced by spark plug

- The spark plug is out of work
- The cable is poorly connected, open or short-circuited
- Poor connection between ECU and ignition coil
- Poor connection between ECU and the main switch
- Poor main switch
- Poor ECU.
- A.C.G. is out of work

Starter motor does not work

- The fuse is blown
- The battery is not fully charged
- Poor main switch
- Poor starter switch
- The front and rear brake switches do not operate correctly
- Starter relay is out of work
- The ignition coil is poorly connected, open or short-circuited
- The starter motor is out of work

Intermittent power supply

- The connector of the charging system becomes loose
- Poor connection of the battery cable
- Poor connection or short-circuit of the discharging system
- Poor connection or short-circuit of the power generation system

Charging system does not operate properly

- Burnt fuse
- Poor contact, open or short circuit
- Poor regulator rectifier
- Poor ACG

Engine does not crank smoothly

- Primary winding circuit
 - Poor ignition coil
 - Poor connection of cable and connectors
 - Poor main switch
- Secondary winding circuit
 - Poor ignition coil
 - Poor spark plug
 - Poor ignition coil cable
 - Current leakage in the spark plug
- Incorrect ignition timing
 - Poor ACG
 - Improper installation of CPS
 - Poor ECU

Weak starter motor

- Poor charging system
- The battery is not fully charged
- Poor connection in the windings
- The motor gear is jammed by foreign material

Starter motor is working, but engine does not crank

- Poor starter motor pinion
 - The starter motor runs in reverse direction
- Poor battery

Battery

Removal

Remove the battery cover.

⚠ CAUTION

- Electrolyte (diluted sulfuric acid) is very toxic. Once it spreading on clothes, skin, or eyes, it will cause burned or blind. In case of being spread, flush with great quantity of water immediately, and then send to hospital.
- When clothes is spread by electrolyte, it will contact with skin. So, it must flush with great quantity water to take off the clothes.

Remove the battery cover.

Disconnect the negative (-) cable from the battery first, then the positive (+) cable.
Remove the battery.

Install the battery in reverse order of removal.

- To prevent form circuit short, connect positive(+) terminal at first, and next negative (-) terminal.

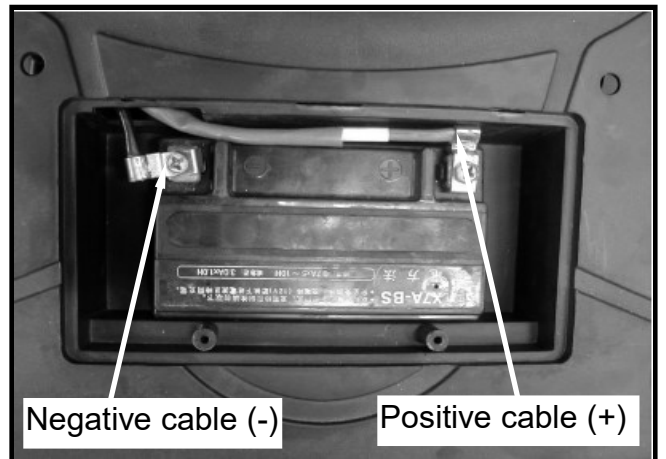
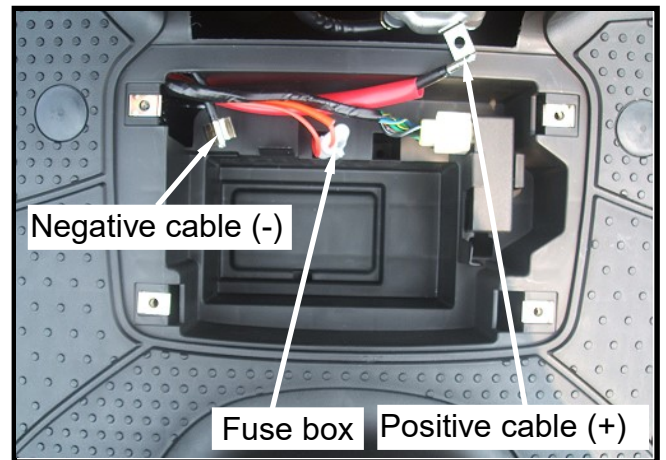

Voltage Check

With a digital voltage meter or multi-meter to measure battery voltage.

Voltage:

Fully charged: 13.0 – 13.2V (at 20°C)

Undercharged: Below 12.3 V (at 20°C)

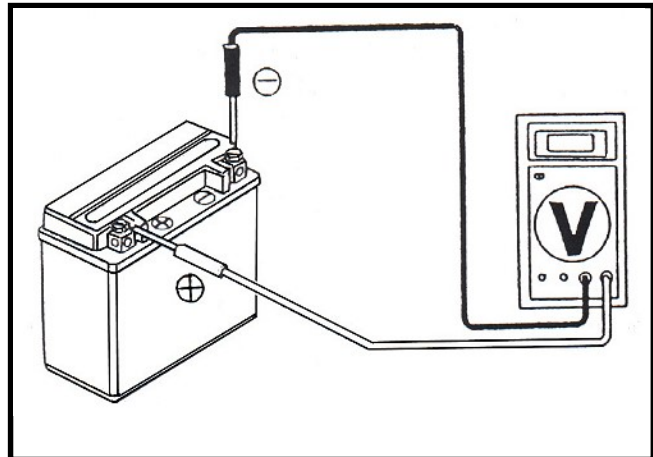

CHARGING

Connect the Charger positive (+) to the battery positive (+) terminal.

Connect the Charger negative (-) to the battery negative (-) terminal.

	Standard	Max.
Charging current	0.6A	6.0A
Charging time	5~10H	1H

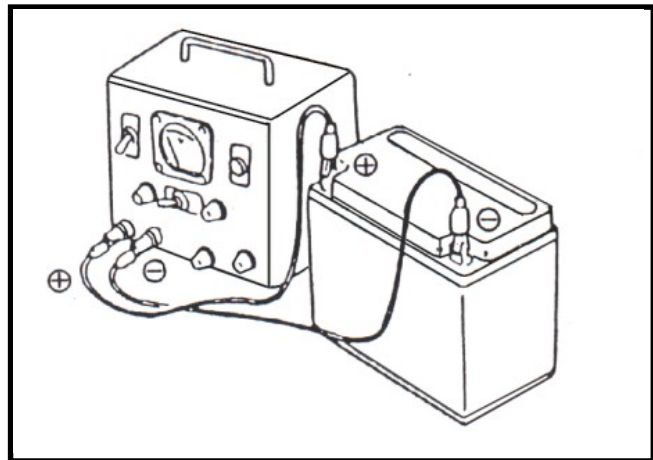

⚠ Warning

- Strictly keep flames away from a charging battery.
- The charging “ON”/ “OFF” is controlled by the charger’s switch. Do not control the charging by battery jump wires.
- Turn the charger’s switch “OFF” at first before or after charging to prevent from sparks created on the connectors and explosion.
- To charge a battery must be based on the battery’s ampere-hour showed on label.

⚠ CAUTION

- Quick charge a battery should be used only in an emergency.
- Make sure the current and charging time of above description.
- The battery will be damaged by too much current or too rush charging.
- When finishing charge, it is necessary to measure voltage after 30 minutes.

After installing the battery, coat the terminals with clean grease.

Charging Voltage/Current Inspection

⚠ Caution

- Before conducting the inspection, be sure that the battery is fully charged. Use a fully charged battery having a voltage larger than 13.1 V. If undercharged, the current changes dramatically.
- While starting the engine, the starter motor draws large amount of current from the battery. Thus, do not start the engine with battery.

After the engine is warmed up, replace original battery with a fully charged battery. Connect a digital voltmeter to the battery terminals.

Connect an ammeter between both ends of the main fuse.

⚠ Caution

When the probe is reversibly connected, use a voltmeter having an indication that the current flows from the positive or the negative direction and the measurement should be at zero, ammeter at one direction only.

⚠ Caution

- Do not use short-circuit cable.
- It is possible to measure the current by connecting an ammeter between the battery positive terminal and the cable position terminal, however, while the starter motor is activated, the surge current of the motor draws from the battery may damage the ammeter. Use the kick lever to start the engine.
- The main switch shall be turned to OFF position during the process of inspection. Never tamper with the ammeter and the cable while there is current flowing through. It may damage the ammeter.

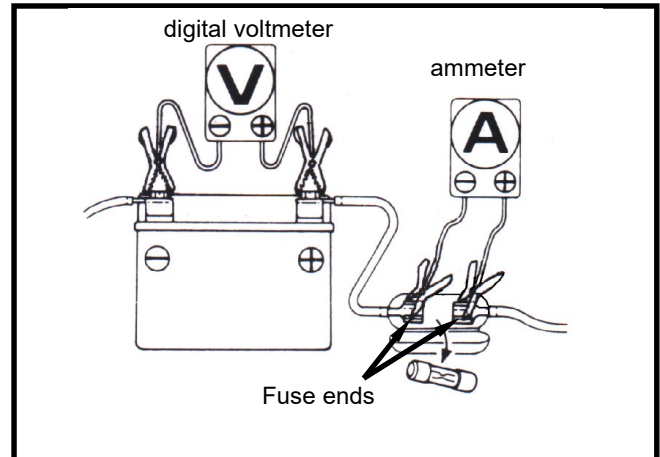

Connect a tachometer.

Turn on the headlight to high beam and start the engine.

Accelerate the engine gradually to the specified revolution per minute and measure the charging voltage/current.

Specified Charging Current:

- | | |
|-----------------|--------------------------|
| (headlight OFF) | 0.6 A or more/2500rpm |
| | 1.2 A or more / 6000 rpm |
| (headlight ON) | 0.4 A or more/2500rpm |
| | 1.0 A or more / 6000 rpm |

Control Charging Voltage:

14.0+/-0.5 V / 2000 rpm

⚠ Caution

To replace the old battery, use a new battery with the same current and voltage.

The following problems are related to the charging system, follow the instructions provided in the checking list to correct it if any one of the problems takes place.

- (1) The charging voltage can not exceed the voltage between two battery terminals and the charging current is in the discharging direction.

- (2) The charging voltage and current are too much higher than the standard values.

The following problems are not related to the charging system; correct it if any by following steps indicate in the checking list.

- (1) The standard charging voltage and current can only reach when the revolution of the engine exceeds the specified rpm.
 - Bulbs used exceed their rate and consume too much power.
 - The replacement battery is aged and does not have enough capacity.
- (2) The charging voltage is normal, but the current is not.
 - The replacement battery is aged and does not have enough capacity.
 - Battery used do not have enough electricity or is over charged.
 - The fuse of the ammeter is blown.
 - The ammeter is improperly connected.
- (3) The charging current is normal, but the voltage is not.
 - The fuse of the voltmeter is blown.

VOLTAGE REGULATOR INSPECTION

Remove the front cover. (screws 4 x 2).
 Remove the front cover mounting bolt(bolt x 1)and remove the left/right turnlight wiring connector.

Disconnect the 4P connector on the diode, and check the continuity between main wire terminals according to following method.

Main wire circuit inspection

Item (wire color)	Judgment
Check voltage between battery terminal (red) and ground (green).	Battery voltage
Check continuity between ground(green) and frame.	Continuity
Check illumination wire (yellow) to ground. (disconnect the connector of the resistor's pin and automatic by-starter pin. Illumination switch is in OFF)	Continuity & resistance
Check charging coil (white) to ground)	Continuity & resistance

If the measured value is abnormal, check the abnormal wire circuit. If components are good, it could be a poor wire circuit.

If all items are in good condition, then replace the voltage regulator.

If main wire circuit check is in normal and there is no loose in the pins of voltage regulator connector, then measure the resistance between the connector of voltage regulator.

Voltage Regulator Check

Unit: Ω

	black	yellow	yellow	yellow	black	red	green	shell
red								
yellow		∞	∞	∞	∞	∞	4	∞
yellow		∞	∞	∞	∞	∞	5	∞
yellow		∞	∞	∞	∞	∞	5	∞
black		∞	∞	∞	∞	∞	8	∞
red		5	5	5	∞	∞	12	∞
green		∞	∞	∞	∞	∞	∞	∞
shell		∞	∞	∞	∞	∞	∞	∞

⚠ Caution

- Do not touch the probe of multi-meter by fingers, then the resistance values will be incorrect because there is some resistance existence in human body.
- To use the multi-meter recommended by SYM. Otherwise, the measured resistance might be different.

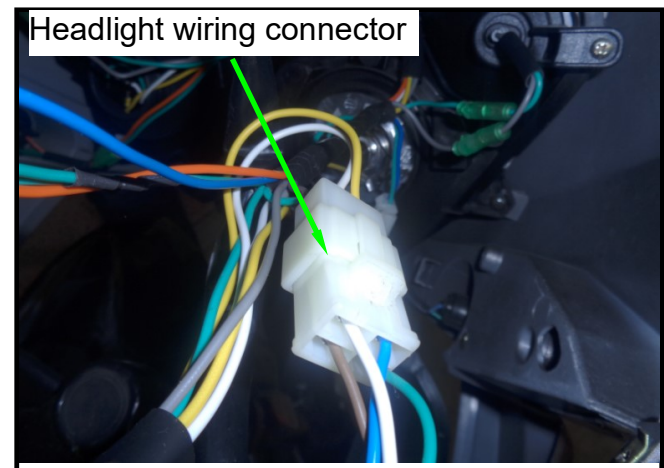
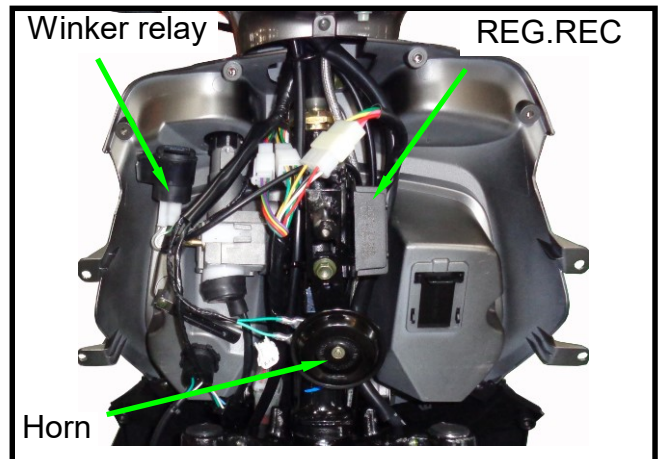

Alternator charging coil**⚠ Caution**

The check of alternator charging coil and illumination coil can be done when the alternator is mounted on engine.

Check

Remove the 2P connector of the alternator. Measure the resistance between the white wire on yellow wire with a multi-meter.

Standard: $0.6 \pm 0.1 \Omega$ (20°C)

Replace the alternator charging coil if the measured value exceeds standard.

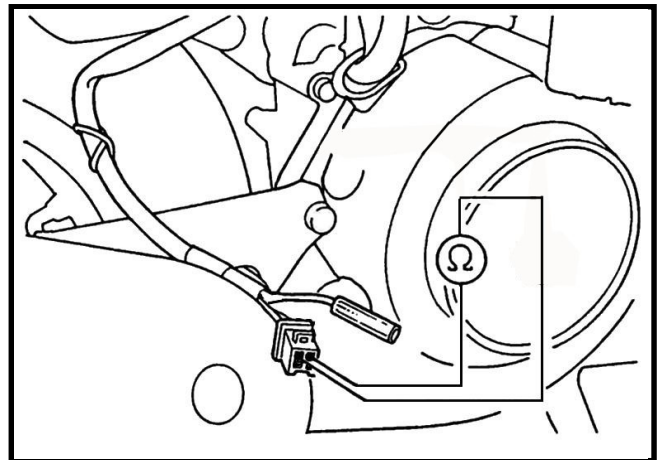
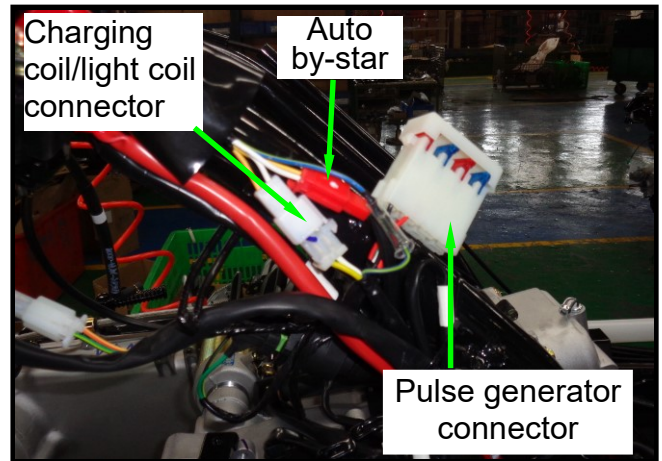

Ignition coil

Removal

Remove the luggage box, center cover.
 Remove spark plug cap.
 Remove the primary coil wire of ignition coil.
 Remove the fix bolts for the ignition coil, and remove the ignition coil.
 Install the ignition coil in reverse order of removal.

⚠ Caution

Install primary coil with black/yellow lead connected to black connector and green lead connected to green connector.

Spark plug confirmation

Remove the spark plug and install a good plug into plug cap, and then ground it to engine ground.
 Make sure its spark condition. If it is in not good or burnt spark plug, replace the spark plug with new one.

⚠ Caution

- Make sure each wire connection is correct, and test as required. Even the wire connection is in correct, sometimes, it might not be tested occurred.

Connect the high voltage shunt with a multi-meter or input a resistor in the 10M Ω 100V of voltage meter.
 Connect ignition coil wires, and connect a shunt between primary terminal (black/yellow and green) and frame ground.
 Press the starting motor button, or starting lever to test the max. primary voltage of ignition coil.
 Connection: connect (+) terminal to green side, and (-) to black/yellow side.

Min. voltage: Above 95 V.

⚠ Caution

Do not touch metal parts on the test probe with fingers to avoid electric shock.

Disconnect the primary coil connector and check the resistance between primary coil terminals.

Standard: 0.21 Ω \pm 10% Ω (at 20°C)

Primary coil is good if resistance within standard.

Primary coil is broken if resistance is infinite.
 Replace the coil.

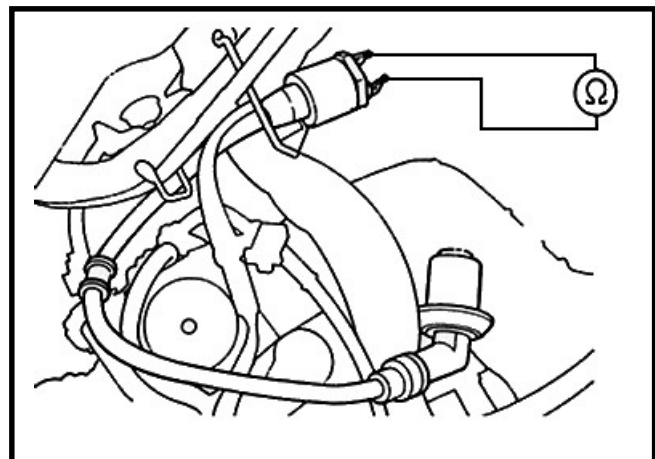
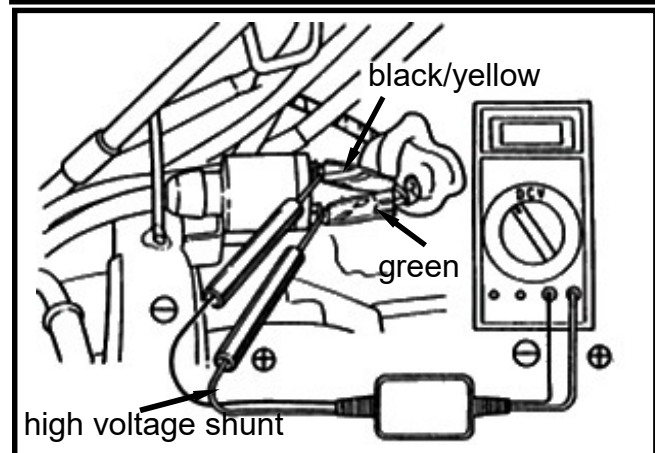
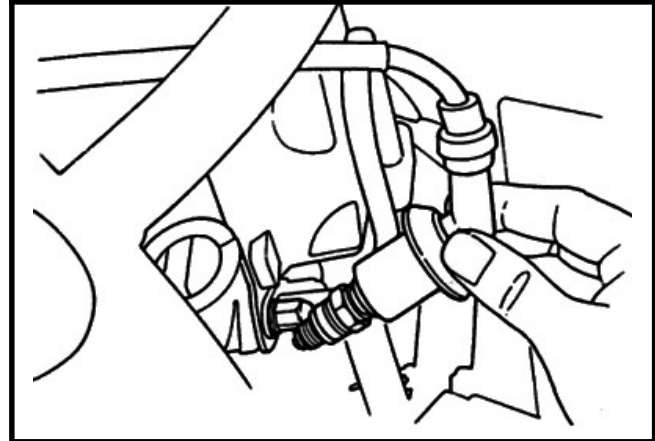
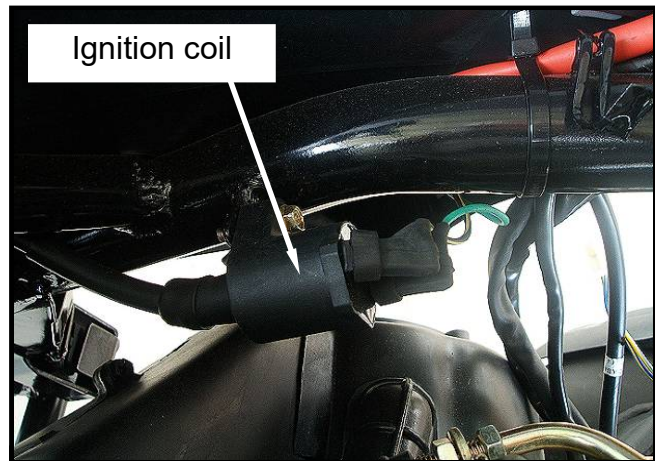

Secondary coil

Attached the spark plug cap, measure the resistance between plug cap side and green terminal.

Standard value: 7-12 k Ω (20°C)

Remove the spark plug cap, measure the resistance between plug cap side and green terminal.

Standard value: 3-5 k Ω (20°C)

Secondary coil is good if resistance within standard.

Secondary coil is broken if resistance is infinite. If the spark plug cap attached and the measured value is exceed standard value, it means the spark plug cap is in not good.

Replacement

Remove the ignition coil bolt to replace the ignition coil if necessary.

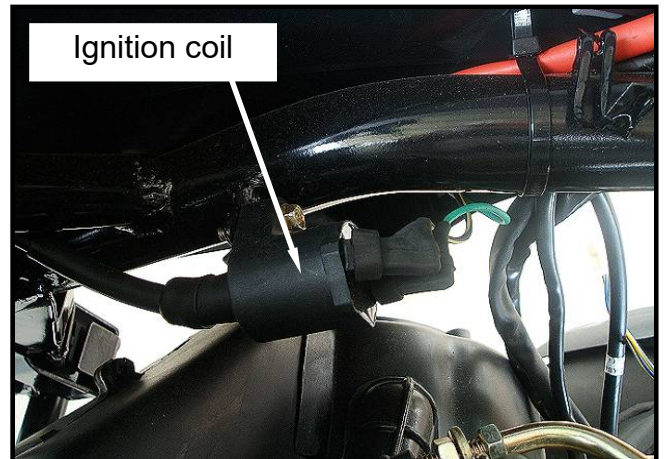
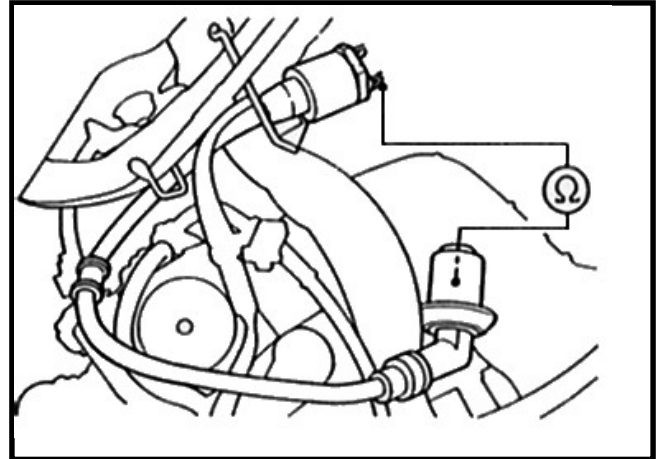
**Pulse generator****⚠ Caution**

Checking pulse generator can be done on engine. But, the spark plug must be installed onto the cylinder head, and cylinder compression pressure must be in normal condition.

Check

Remove body cover.

Remove the pulse generator connector.

Measure the resistance between blue/yellow terminal on engine side and frame ground.

Standard: 140 ± 20 Ω (20°C)

Replace the alternator if the measured value exceeds standard value.

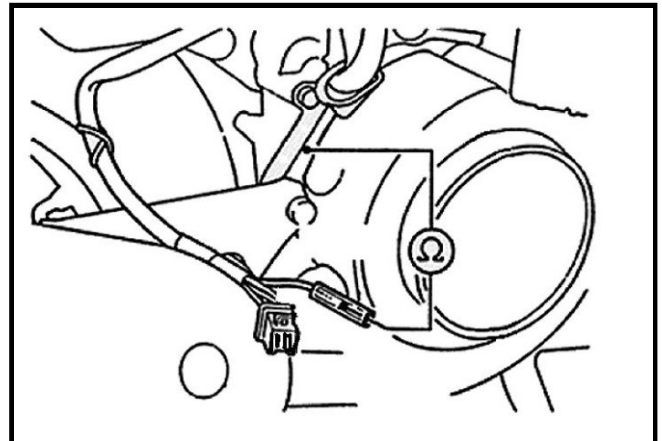

STARTING SYSTEM

Starting Circuit

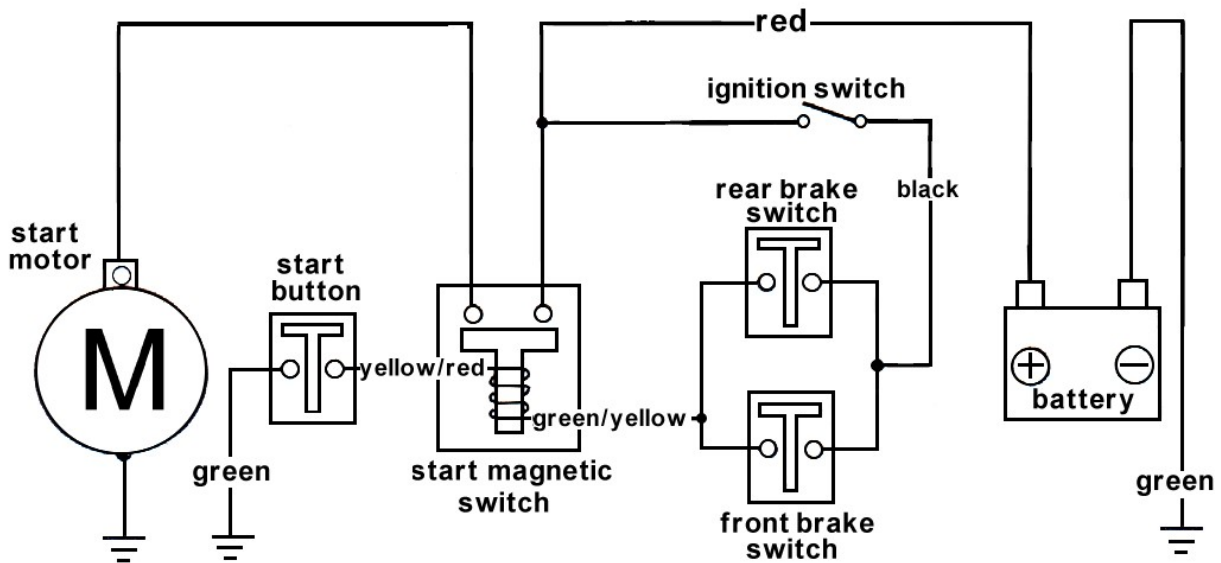

Starter magnetic switch inspection

Turn main switch to "on", and operate the brake lever. Then press starting button to check if there a click sound. It is normal if there is a click sound.

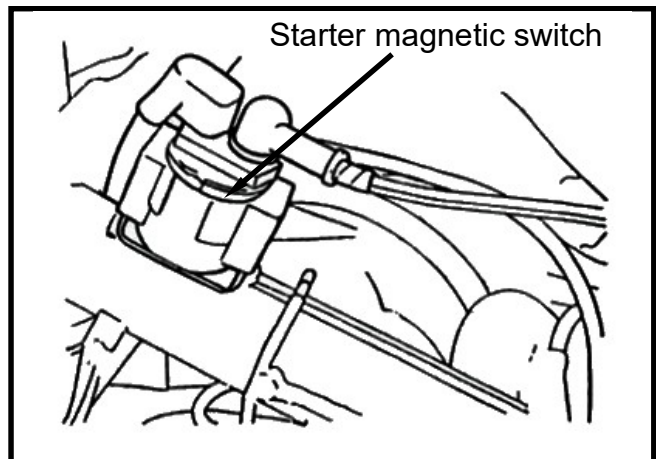

Remove the luggage box.
 Disconnect the battery negative (-) terminal.
 Remove the battery positive (+) connection and starting motor wires from the starter magnetic switch large pin.
 Remove the power control connector of the Starter magnetic switch.
 Connect a Ohmmeter between the Starter magnetic switch large pins.
 Connect the green/yellow wire to battery positive (+) terminal, and yellow/red to battery negative (-) terminal.
 Check the continuity between the Starter magnetic switch large pins. If it is not continuity, then replace the starter magnetic switch.

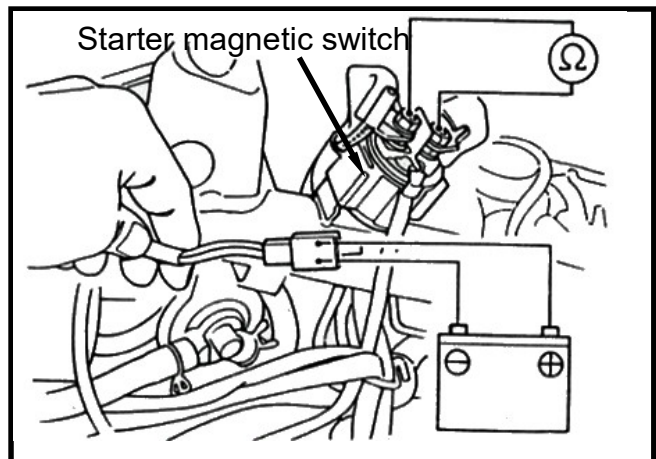

Starting Motor Removal

Remove the battery cover.
Firstly, remove the battery negative (-) terminal, and then remove the positive (+) terminal.
Remove the luggage box.
Remove the starting motor power wire.
Remove the starting motor mounting bolts and motor.

Starting Motor Installation

Install the motor in reverse order of removal.

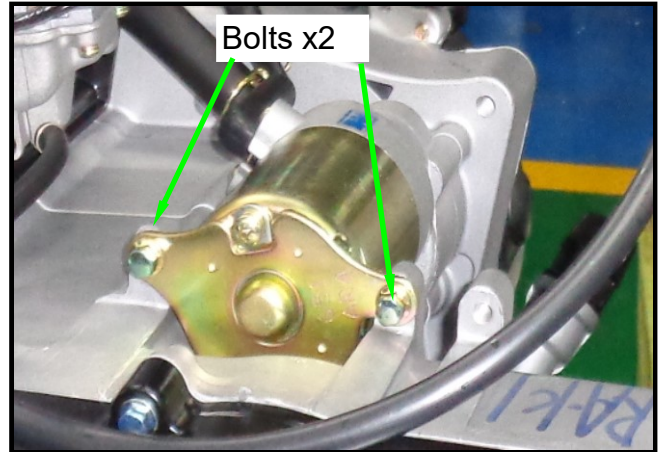

METER

Removal

Remove the front cover.

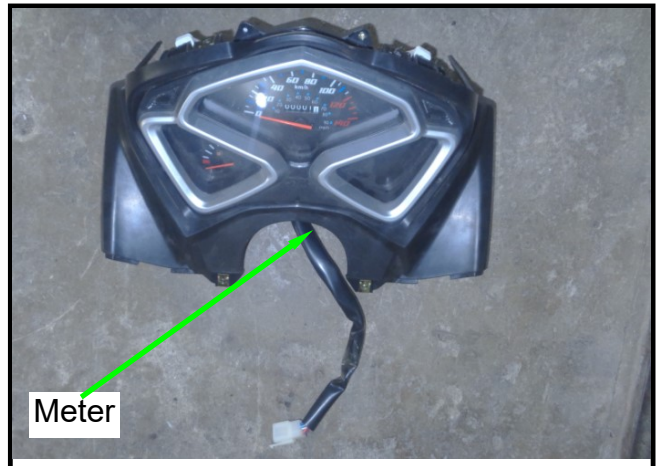

Remove the speedometer cable.

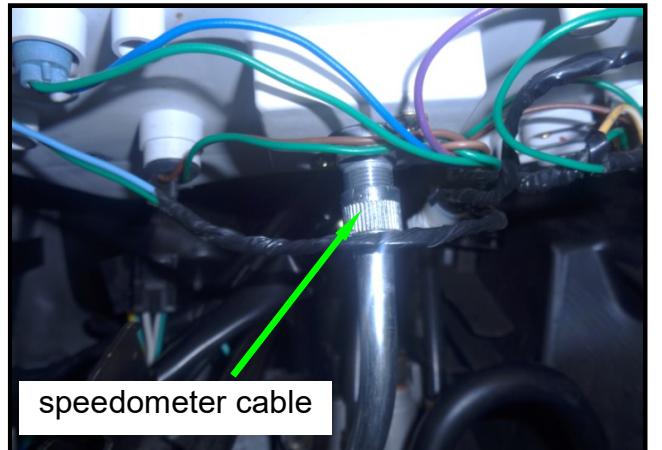

Remove the front cover.
Remove the power connector of the meter.

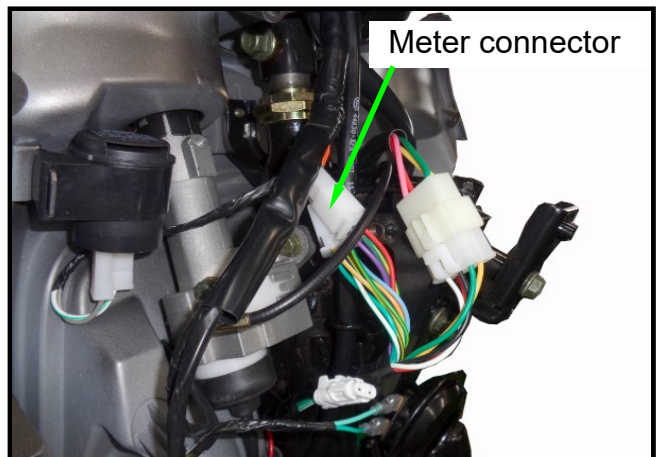

Remove the front cover.
Remove the meter mounting screws.
Take out the meter.

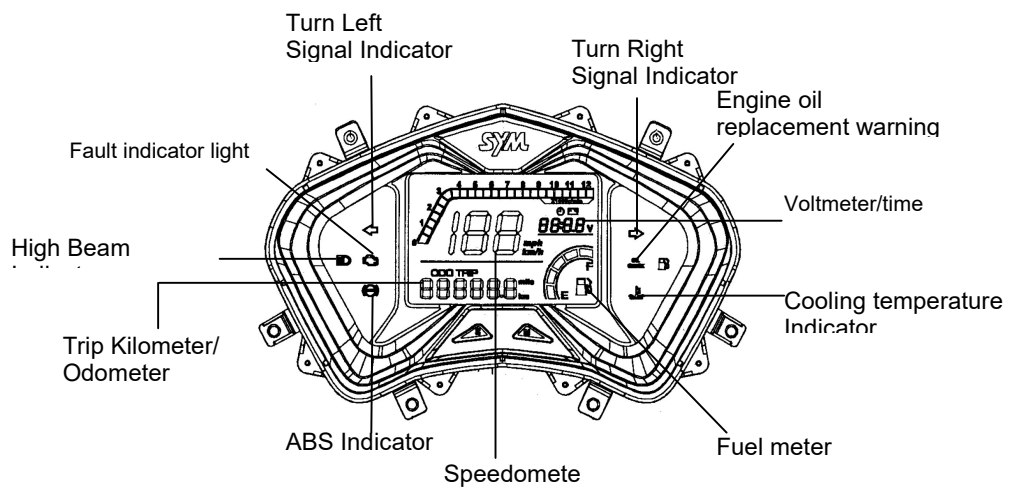
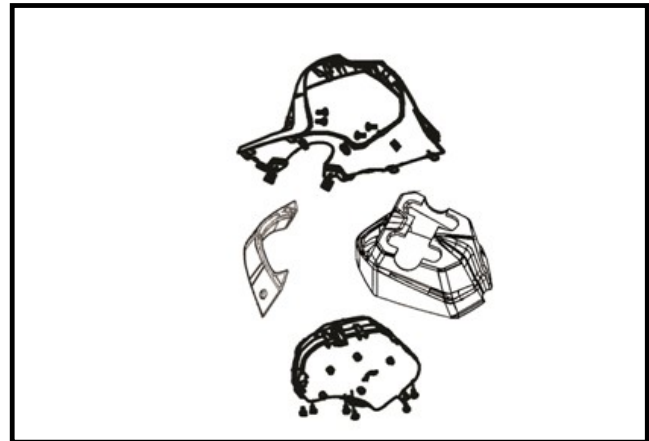

Caution

Do not wipe the meter or headlight with organic solvent such as gasoline to prevent from damage these components.

Installation

Install the meter in reverse order of removal.

LIGHT/BULBS**Headlight Bulb Replacement**

Rear the front handle cover.

Disconnect the headlight wire connector.

Press down the bulb spring locker and then remove the locker with turning it left motion.

Remove the bulb.

Replace the bulb with new one if necessary.
(12V 35/35W)

⚠ Caution

- Do not touch the bulb surface with fingers because the bulb will create hot-spot so that let it be burnt. It has to be package with cloth or wear glove as installing.
- Wipe the bulb with cloth to prevent from damaged if the bulb be touched by hands.

Install the bulb in reverse order of removal.
Turn the main switch ON/OFF to check if the bulb has been installed properly after installation.

Please conduct the headlight beam adjustment job if replace the headlight bulb.

The headlight beam adjustment

Loosen the adjustment bolt located under the headlight.

⚠ Caution

- This outer cover of headlight is a fixed type so that the light seat will be moved only when adjusting.

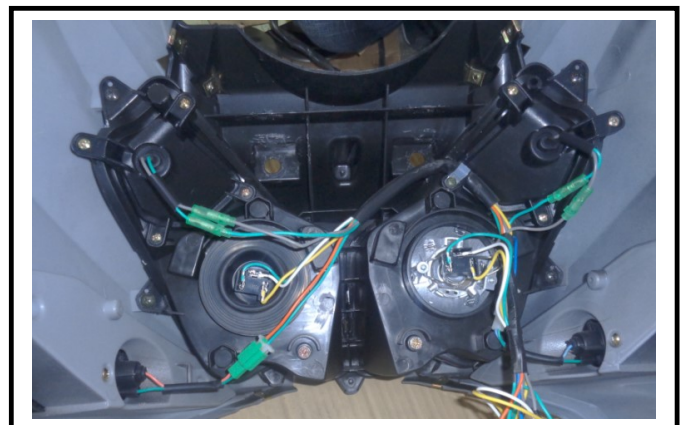

Front Turn Signal Lamp Bulb Replacement

Remove the front handle cover.
Remove the wire connector of the turn signal light.

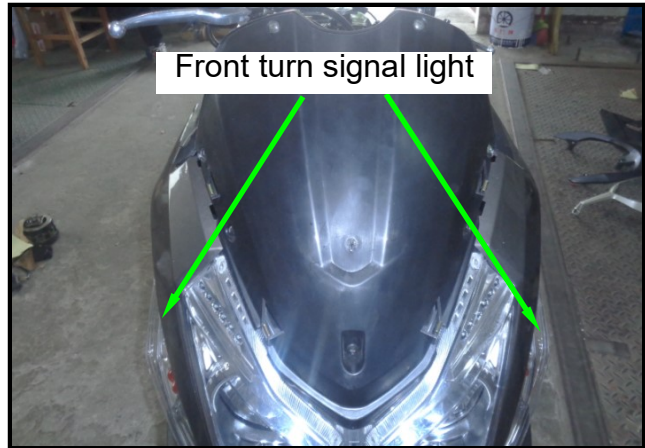

Pull out the bulb and replace it with new one. (12V 10W)

Installation

Install the bulb in reverse order of removal.

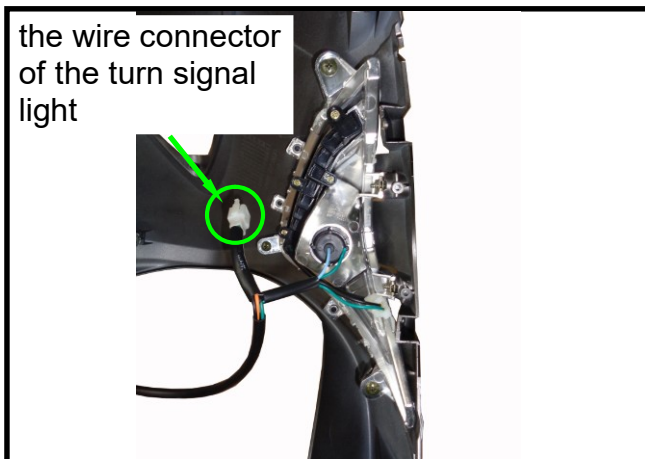

Bulbs Replacement of tail light/brake light/rear turn signal light.

Remove the 2 screws of the taillight & left/right turn light lens.

Remove the tail light assembly.

Installation

Install the bulb in reverse order of removal.

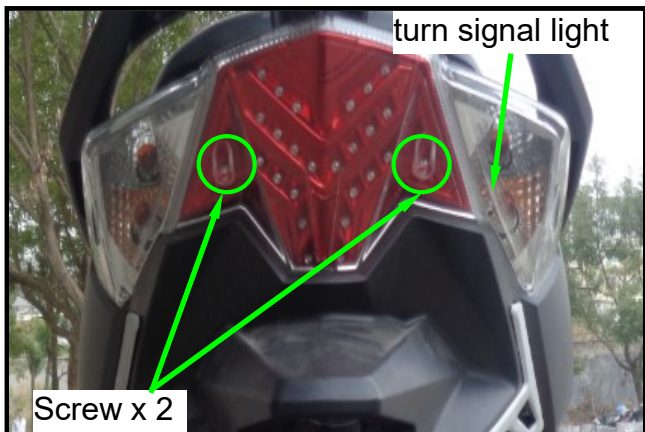

MAIN SWITCH/HORN

Main Switch

Check

Remove the headlight connector and the front cover.

Disconnect main switch leads connector.

Check connector terminals for continuity.

		color	
		Black	Red
Location	LOCK		
	OFF		
	ON	● ————— ●	

Replacement

Remove the main switch connector and fixing bolts (bolts x 2)

Remove the main switch.

Install a new main switch and tighten the bolts. (bolts x2)

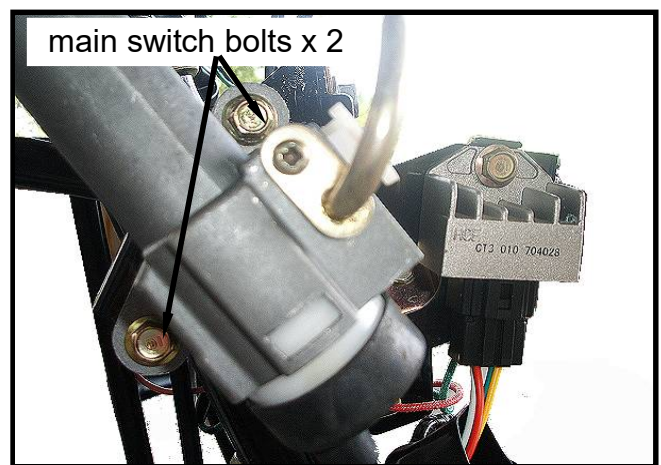
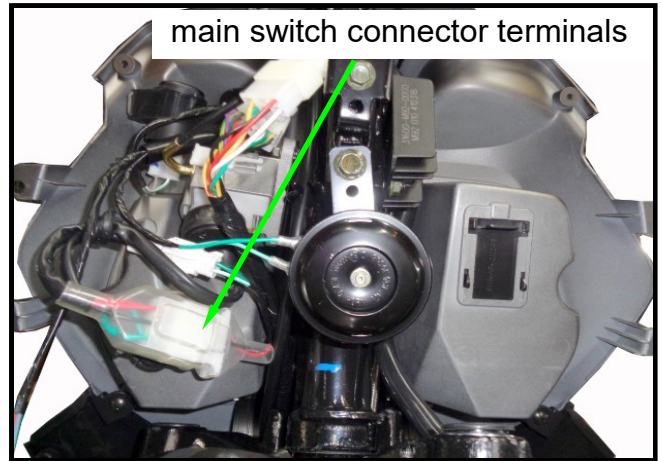

Handle switch

Remove the front handle cover.
 Disconnect the connector of the handle switch.
 Check the continuity of follow pins listed below columns.



Starting switch

Location \ color	Yellow/red	Yellow/green
FREE		
	● ——— ●	● ——— ●

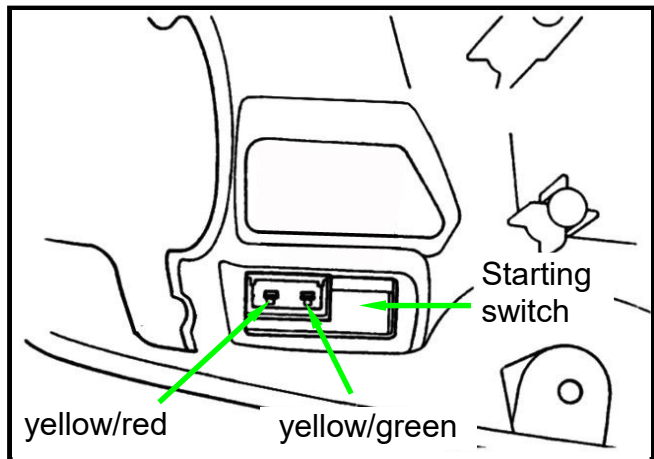

High/Low beam switch/ seat open

Location \ color	blue	white	brown/white	black	purple
	● ——— ●		● ——— ●		
		● ——— ●			
seat open	● ——— ●		● ——— ●	● ——— ●	

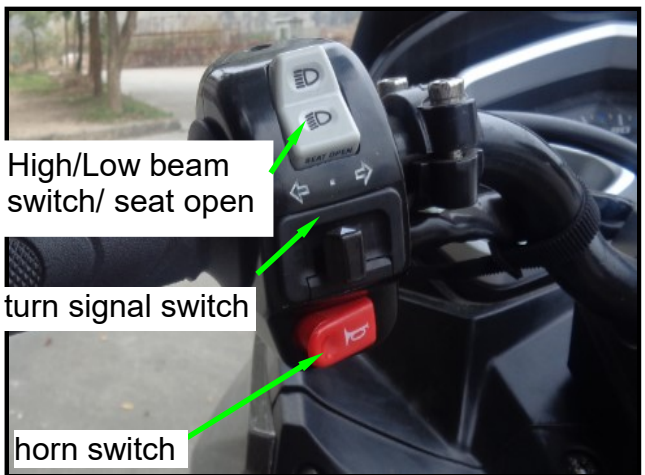

Horn switch

Location \ color	White/green	blue/green
FREE		
	● ——— ●	● ——— ●

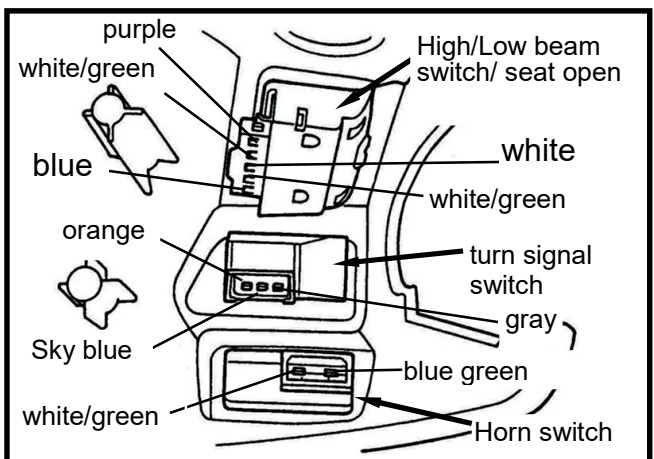

Turn signal light switch

color		Sky blue	Gray	orange
Location				
→		● — ●		
N	FROM R	● — ●		
	PUSH OFF			
	FROM L		● — ●	
←			● — ●	

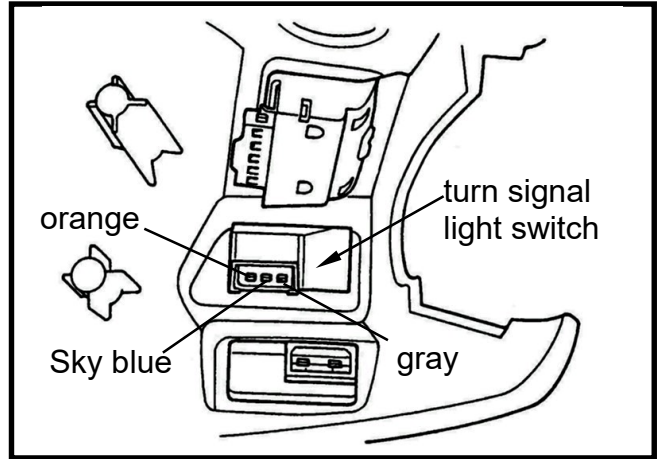

Brake light switch

The circuit of black wire and the green/yellow wire on the brake light switch should be in continuity when operating the brake lever.

If the switch damaged, replace it with new one.

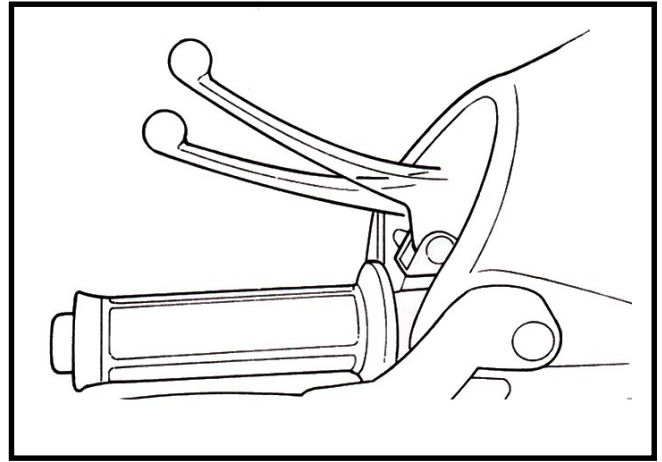

Horn

Remove the front cover.

Connect the light blue wire on the horn to the battery positive (+) terminal, and the green wire to the battery negative (-) terminal.

Then, the horn should sound.

Replace it if necessary.

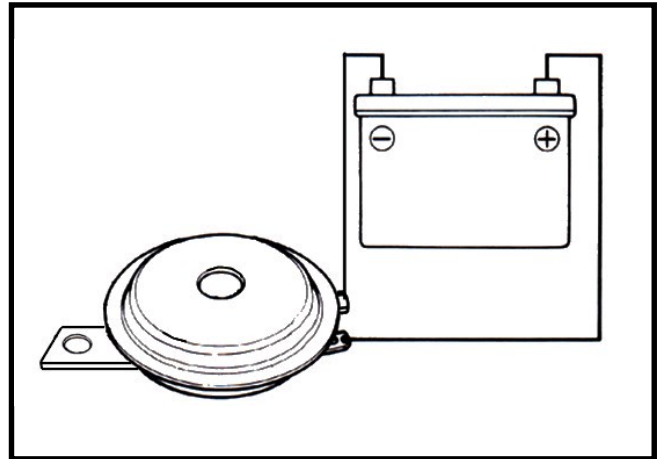

FUEL UNIT

- Open the seat.
- Remove the luggage box(bolts x 4) .
- Remove the R.R. carrier(bolts x 3) .
- Remove the body cover.
- Disconnect the fuel unit wire connector.

⚠ Caution

Do not damage or bend the float arm as removing.

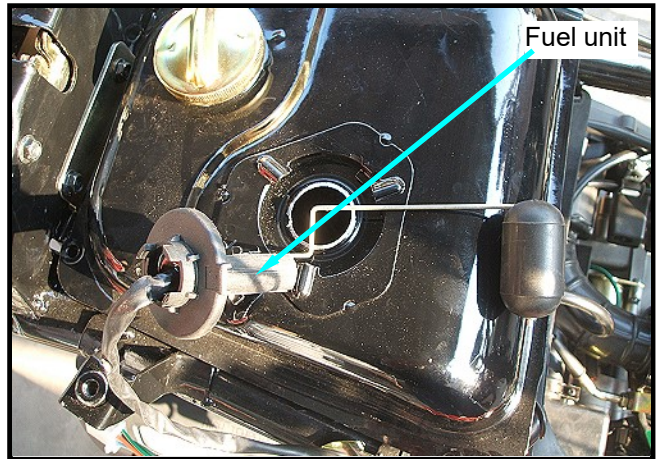

The resistance values are listed below when the float arm in “F” and “E” positions.

Float arm position	Resistance value
E(empty)	97.5~107.5Ω
F(full)	4~10Ω

- DOWN(empty)Connect the fuel unit to the main harness.
- Turn the main switch “ON” position.
- Move the float arm in “UP” & “DOWN”, and then check if the fuel unit indication needle is in correct position.

⚠ Caution

Turn on the turn signal light to make sure battery is in good condition before this test.

Float arm position	Indicator needle
UP(full)	E(empty)
DOWN(empty)	F(full)

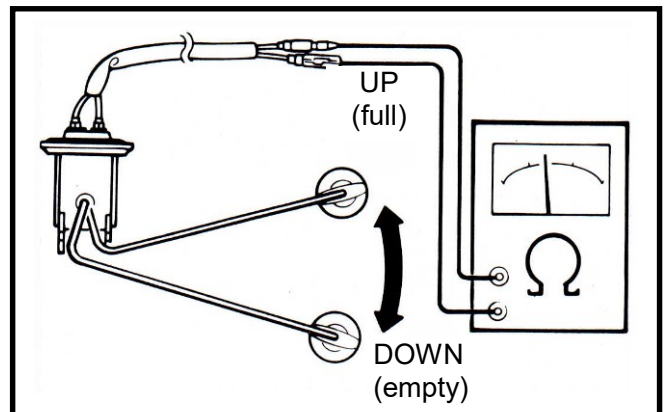

Installation

Install the fuel unit in reverse order of removal.

