

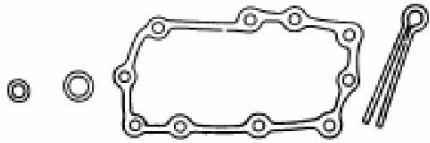
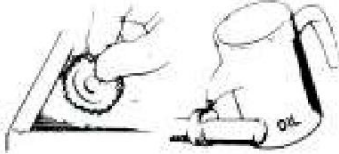
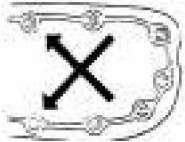
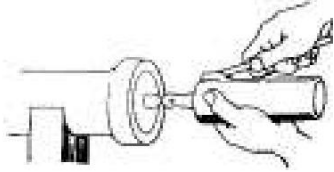

SERVICE RULES.....	1-1	TORQUE VALUES.....	1-3
SPECIFICATIONS.....	1-2	TROUBLE SHOOTING	1-4

SERVICE RULES:

<p>(1)Use new packings, gaskets,O-rings and cotter pins space and clips whenever reassembling.</p> 	<p>(5)Clean all removed parts in or with solvent, and lubricate their sliding surfaces upon disassembly.</p> 
<p>(2)When tightening bolts or nuts, begin on center or larger diameter bolts and tighten them in criss-cross pattern in two or more steps if necessary.</p> 	<p>(6)Coat or fill parts with specified grease where specified.</p> 
<p>(3)Use genuine SANYANG parts and lubricants or those equivalent. When parts are to be reused, they must be inspected carefully to make sure they are not damaged or deteriorated and in good usable condition.</p> 	<p>(7)Upon assembling, check every possible part for proper installation and movement or operation.</p> 
<p>(4)Use special tool when use of such a tool is specified.</p> 	<p>(8)Work safely and give your work your undivided attention. Exchange signals as frequently as possible when a work involves two or more workers. Do not run the engine unless the shop or working area is well ventilated.</p> 

Symbol Marks:

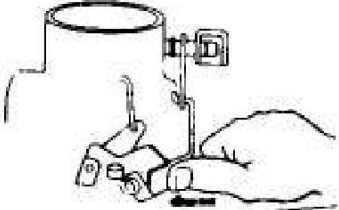
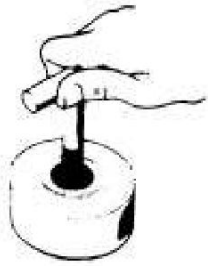
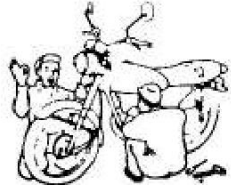
-  :Apply engine oil.
-  :Apply grease.

NOTE: Things must be noticed.

CAUTION: Things that could cause damage to the engine parts.

WARNING: Things that could cause damage to the person or partner.

1.GENERAL INFORMATION



SPECIFICATIONS

	ITEM	MG12B1-EU(NDC)	
DIMENSIONS	Overall length	2068mm	
	Overall width	860mm	
	Overall height	1195mm	
	Wheel base	1405mm	
	Ground clearance	160mm	
	Dry weight	150kg	
FRAME	Type	Single pipe	
	Front suspension and travel	Telescope 140mm	
	Rear suspension and travel	Swing arm 42.5mm	
	Front tire size and tire pressure	110/70-17 1.75Kg/C m ²	
	Rear tire size and tire pressure	130/70-17 2.25Kg/C m ²	
	Front brake	Disk type	
	Rear brake	Disk type	
	Fuel capacity	11.0 liter	
ENGINE	Caster angle	25°	
	Type	Air cooled 4 stroke engine	
	Cylinder arrangement	Single cylinder 15~ inclined from vertical	
	Bore & stroke	56.5 x49.5mm	
	Displacement	124.1 c.c.	
	Compression ratio	10.1:1	
	Oil capacity	1.0 liter (0.85 liter for change)	
	Intake valve	opens	5° BTDC
		closes	25° ABDC
	Exhaust valve	opens	30° BBDC
		closes	-5° ATDC
	Valve clearance	IN.	0.05mm
		EX.	0.15mm
	Idle speed	1500±100 rpm	
	Maximum Horsepower	7.5 kw/8500 rpm	
Maximum torque	9.5 N.m/6500 rpm		
DRIVE TRAIN	Clutch	Wet multi-plate type	
	Transmission	5-speed international	
	Primary reduction ratio	3.333	
	Gear ratio	I	2.769
		II	1.882
		III	1.273
		IV	1.130
		V	0.960
Final reduction ratio	3.267		
Gearshift pattern	1-N-2-3-4-5		
ELECTRICAL	Ignition system	EFI	
	Ignition timing	"F" mark	BTDC 15°±20° /1500rpm
		Full advance	BTDC 29.5°±2° /4000rpm
	Starting system	Electrical motor	
	Alternator	A.C. generator	
	Battery capacity	12V/6Ah	
	Fuse	15A×3 and 20A×1	
Spark plug	DPR8EA-9		



1.GENERAL INFORMATION

	Spark plug gap	0.6~0.7mm
	Front light bulb(high, low) Position Lamps	12V 14W(1 LED)/25W(1 LED) 12 V 1.5 W (6 LEDs) × 2
	Tail light Stoplight Position Lamps	13.5 V 5.5W (15 LEDs×) 1 13.5 V 2.5W (15 LEDs×) 1
	Turn signal light bulb front Turn signal light bulb rear	13.5V 1.8W(3 LEDs) × 2 13.5V 1.8W(3 LEDs) × 2

1.GENERAL INFORMATION



ENGINE

TIGHTEN LOCATION	Q'TY	THREAD DIA(mm)	TORQUE(kgf.m)
Pulse generator bolts	2	5	0.40~0.70
A.C. generator flange bolt	3	5	0.40~0.70
Starting clutch outer bolt socket	3	8	1.00~1.50
Drain plug bolt	1	12	1.50~2.50
R. Crank case SH. flange bolt	11	6	0.80~1.20
Gear shaft drum stopper hex bolt	1	6	0.80~1.20
Gear shift cam hex bolt	1	6	0.80~1.20
Cylinder/cylinder head two-ends bolts	4	8	1.80~2.20
Cam chain setting plate SH. flange bolt	1	6	0.80~1.20
Cylinder head cap nut	1	8	2.80~3.00
Cylinder head side SH. flange bolt	2	6	0.80~1.20
Tensioner pivot bolt	1	6	0.80~1.20
Sprocket drive hex bolt	2	6	1.00~1.50
Valve adjustment fixing nuts	2	5	1.20~1.40
Chain adjuster SH. flange bolt	2	6	0.80~1.20
Oil filter screen cover	1	10	1.50~3.00
Tappet adjusting hole cap flange bolt	4	6	0.80~1.20
Fly wheel bolt	1	10	4.00~5.00
L. Crank case cover bolt	7	6	0.80~1.20
Reduction gear cover	2	6	0.80~1.20
Starter motor bolt	2	6	0.80~1.20
Oil pump HEX bolt	2	6	0.70~1.10
Oil filter rotor lock nut	1	16	4.00~5.00
R. Crank case cover bolt	12	6	0.80~1.20
Primary drive gear nut	1	16	4.00~5.00
Balancing shaft lock nut	1	12	4.00~5.00

FRAME

TIGHTEN LOCATION	Q'TY	THREAD DIA(mm)	TORQUE(kgf.m)
Front wheel axle nut	1	14	6.00~8.00
Rear wheel axle nut	1	14	10.00~12.00
Rear cushion upper bolt	1	10	3.50~4.50
Rear cushion lower bolt	1	10	3.50~4.50
Drive sprocket bolt	2	6	1.00~1.40
Brake hose bolt	2	10	3.00~4.00
Front brake caliper bolt	2	8	3.70~4.30
Steering stem nut	1	22	6.00~8.00
Front fork upper lock nut	2	10	3.00~3.50
Front fork lower lock nut	2	10	3.00~3.50
Engine front hanger nut	4	8	2.40~3.00
Engine upper hanger plate nut	3	8	2.40~3.00
Engine rear hanger nut	2	10	4.50~5.50
Handle pipe upper holder bolt	4	6	1.00~1.40
Front fork top bridge	2	10	3.00~3.50

STANDARD TORQUE

TYPE	TIGHTEN TORQUE	TYPE	TIGHTEN TORQUE
5mm bolt、nut	0.45~0.60kgf-m	3mm screw	0.05~0.08kgf-m
6mm bolt、nut	0.80~1.20kgf-m	4mm screw	0.10~0.15kgf-m
8mm bolt、nut	1.80~2.50kgf-m	5mm screw	0.35~0.50kgf-m
10mm bolt、nut	3.00~4.00kgf-m	6mm screw、SH nut	0.70~1.10kgf-m
12mm bolt、nut	5.00~6.00kgf-m	6mm bolt、nut	1.00~1.40kgf-m
		8mm bolt、nut	2.40~3.00kgf-m
		10mm bolt、nut	3.50~4.50kgf-m

Troubleshooting-EFi model

A. Engine cannot be started or difficult to be started

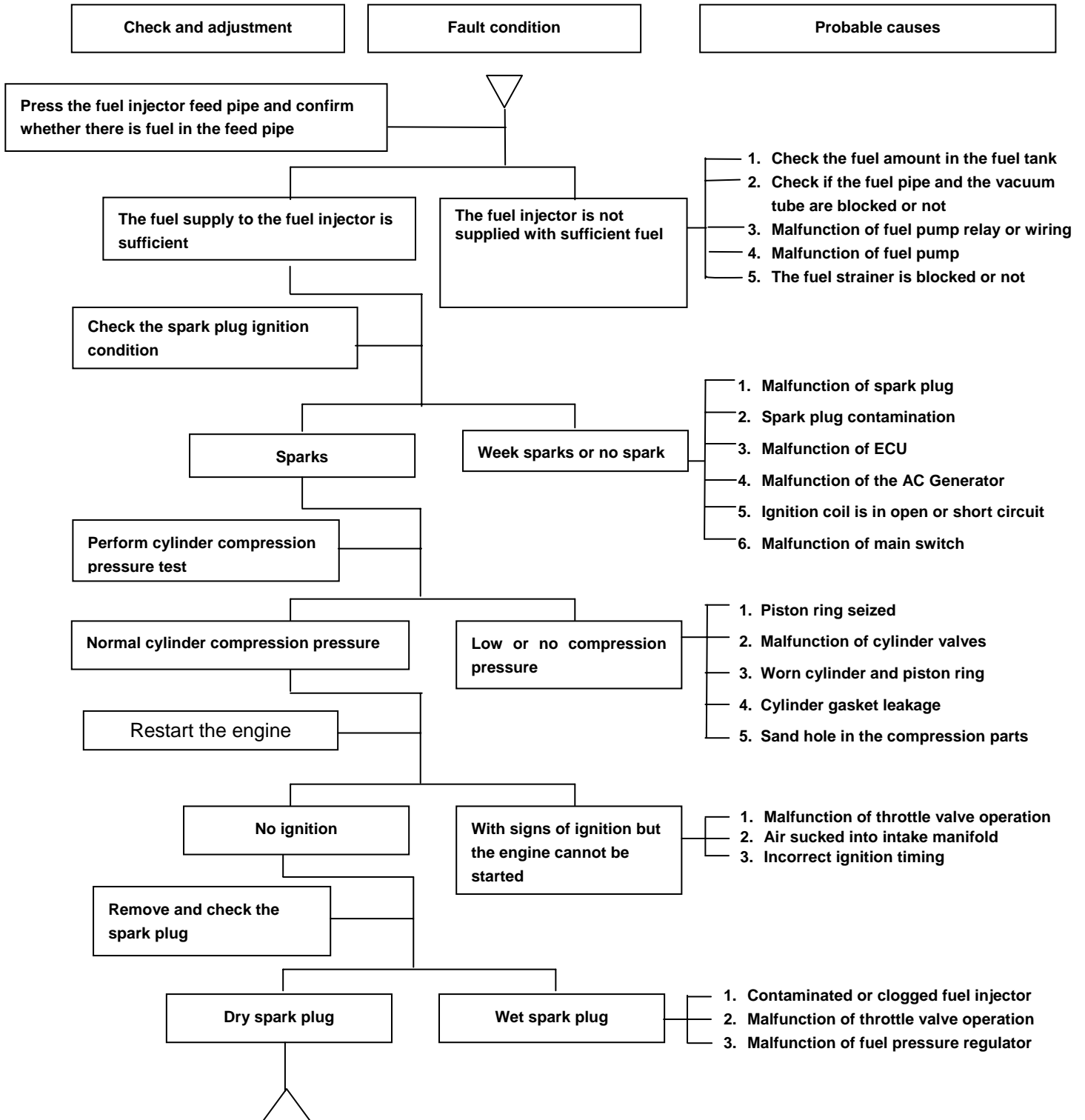

B. Engine runs sluggish (Speed does not pick up, lack of power)

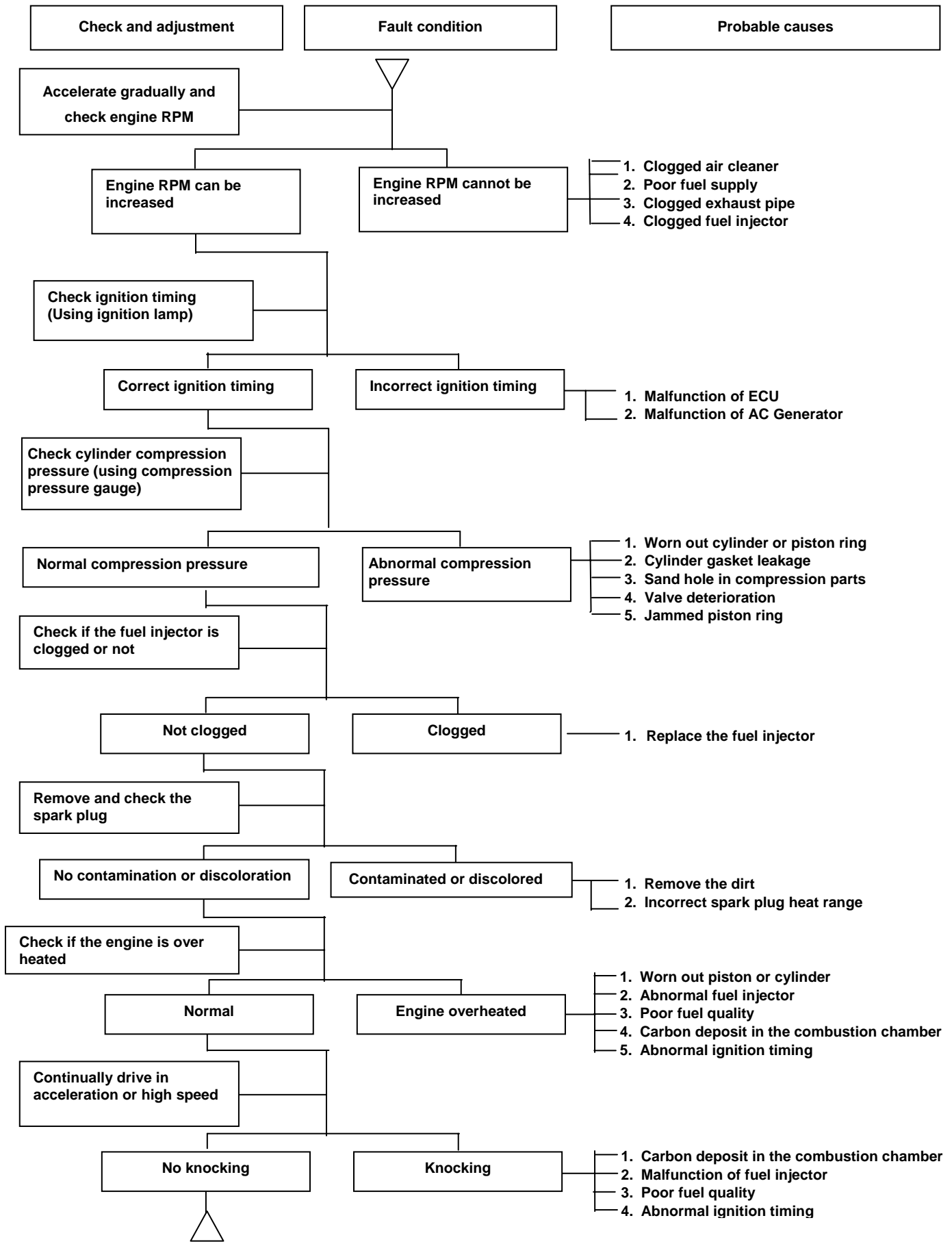

C. Engine runs sluggish (especially in low speed and idling)

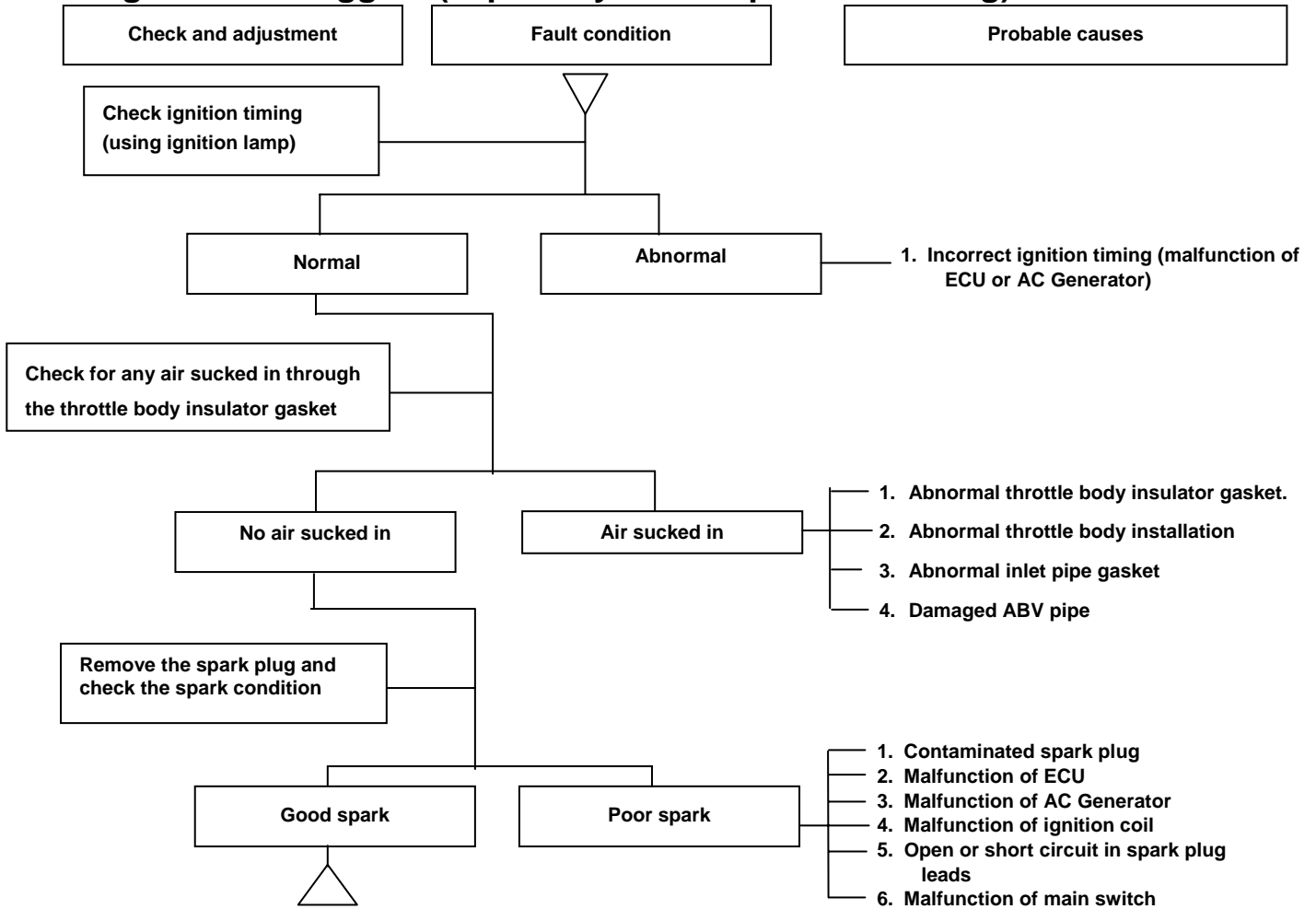

D. Engine runs sluggish (High speed)

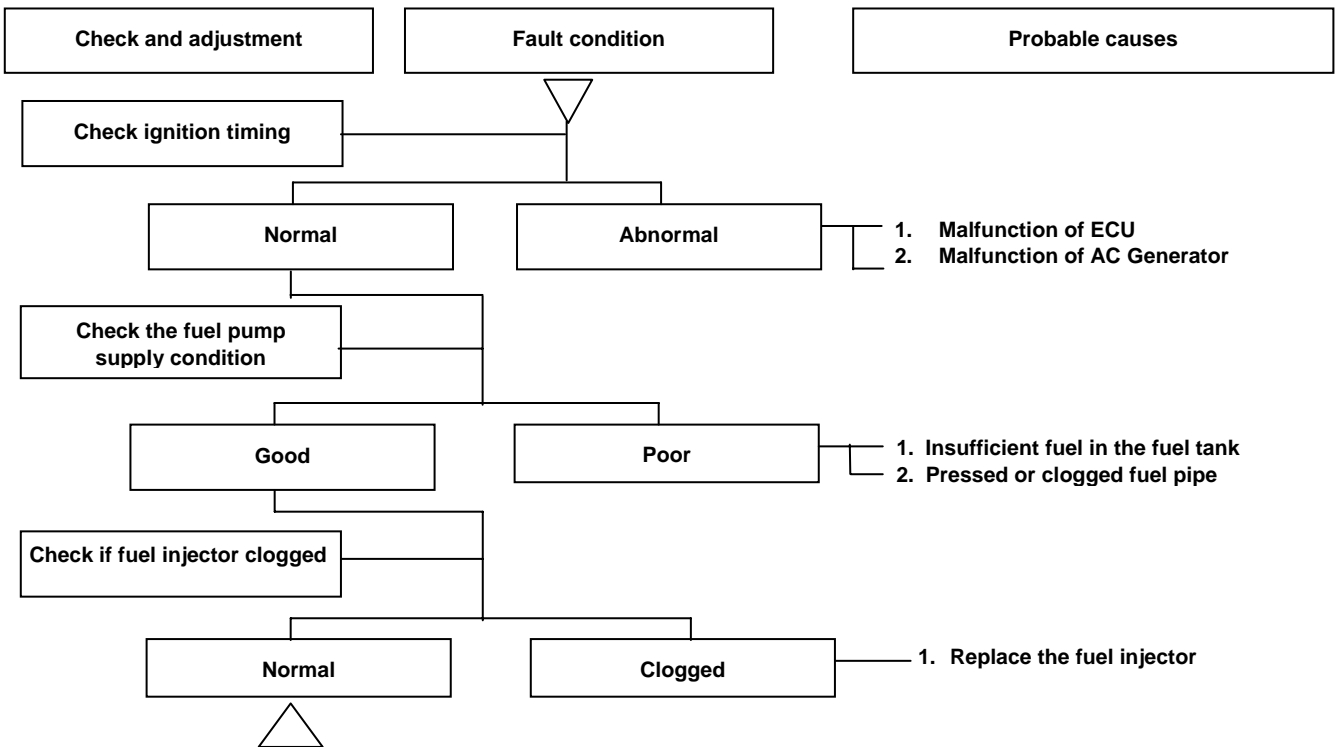

ENGINE	FRAME
MAINTENANCE SCHEDULE 2-2	AIR CLEANER 2-12
SERVICE INFORMATION..... 2-3	CLUTCH ADJUSTMENT..... 2-12
ENGINE OIL/OIL FILTER 2-4	BRAKE ADJUSTMENT 2-13
SPARK PLUG..... 2-5	DRIVE CHAIN ADJUSTMENT 2-14
COMPRESSION TEST..... 2-6	WHEELS/RIM..... 2-15
VALVE CLEARANCE 2-7	SUSPENSION..... 2-16
IGNITION TIMING 2-8	STEERING 2-17
CAM CHAIN TENSION ADJUSTMENT. 2-9	BATTERY..... 2-17
THROTTLE GRIP ADJUSTMENT..... 2-10	HEAD LIGHT AIM..... 2-18
IDLING SPEED ADJUSTMENT..... 2-11	STOPLIGHT SWITCH..... 2-18

PRECAUTIONS IN OPERATION

Specification

Fuel Tank Capacity	Main	11.0 liter
Engine Oil	capacity	1.0 liter
	change	0.85 liter
Clearance of throttle valve		2~6 mm
Spark plug		DPR8EA-9/Gap: 0.6~0.7 mm
Idling speed		1500±100 rpm
Valve clearance: IN/EX		0.05 mm/0.15 mm (125c.c)
Tire dimension	front / rear	110/70-17 / 130/70-17
Tire pressure (cold)	single	Front: 1.75 kg/cm ² rear: 2.00 kg/cm ²
	Two persons	Front: 2.00kg/cm ² rear: 2.25 kg/cm ²
Battery		12V6Ah
Play of drum brake lever		10~20 mm

2.INSPECTION/ADJUSTMENT



MAINTENANCE SCHEDULE

Item	Maintenance kilometer	300KM	Every 1000KM	Every 3000KM	Every 6000KM	Every 12000KM
		NEW	1 Month	3 Months	6 Months	1 Year
1	Air cleaner	I	C			R
2	Gasoline filter	I			C	R
3	Oil filter	C	Replacement for every 5000KM R			
4	Oil filter screen	C	Cleaning for every 5000km C			
5	Engine Oil	R	Replacement for every 1000KM R			
6	Wheels tires	I	I			
7	Battery	I	I			
8	Brake and operation free play	I	I			
9	Steering stem bearing				I	
10	FR./RR. Cushion	I		I		
11	Screws/nuts	I	I			
12	Spark plug	I		R		
13	Clutch	I		I		
14	Frame of lubrication				L	
15	Exhaust muffler	I	I			
16	Carburetor	I	I			
17	Ignition timing	I	I			
18	Emission	I	I			
19	Idle speed	I	I			
20	Gasoline system	I		I		
21	Throttle cable	I		I		
22	Engine bolt torque	I		I		
23	Deposit of exhaust outlet					I
24	Cylinder head/cylinder Piston exhaust system deposit			I		
25	Cam chain	I		I		
26	Valve clearance	I				
27	Light/electrical appliance/Meter	I	I			
28	Side stand & Spring	I			I	

The table is referred to the driving distance about 1000km per month

I-inspection, cleaning, adjustment or replacement (if necessary)R-replacement C-leaning L-lubrication

REMARK: Ridden in unusually dusty areas, require more frequently air filter element cleaning.

SERVICE INFORMATION SPECIFICATION

ENGINE

Oil capacity	1.0 L(0.85 L for change)
Spark plug	DPR8EA-9
Spark plug gap	0.6-0.7mm
Valve clearance IN	0.05 mm(125c.c)
EX	0.15 mm(125c.c)

FRAME

Clutch lever free play	10-20mm
Drive chain slack	10-20mm
Front brake lever free play	10-20mm
Rear brake pedal free play	20-30mm
Throttle grip free play	2-6mm

Cylinder compression 9.5kg/c m²±1kg/c m²

SPECIAL TOOL

Valve clearance adjuster

TORQUE VALVES

Right crankcase cover	0.80-1.20 kgf.m
Front fork top bridge bolt	3.00-3.50 kgf.m
Rear wheel axle nut	10.0-12.0 kgf.m
Rear shock absorber upper bolt	3.50-4.50 kgf.m
Rear shock absorber lower bolt	3.50-4.50 kgf.m

2.INSPECTION/ADJUSTMENT



OIL/OIL FILTER OIL LEVEL CHECK

Start and warm up the engine for few minutes,then stop the engine.

Check the oil level through the view window after a few minutes.

If the oil level is near the lower mark,fill the oil to the upper limit with the recommended grade oil.



OIL REPLACEMENT

NOTE:

Drain the engine oil while the engine is warm.

Remove the oil discharge bolt or oil filter screen cover, and drain the engine oil.

NOTE :

Make sure that the oil filter screen cover O-ring is in good condition.

If the oil level is near the lower mark,fill the oil to the upper limit with the recommended grade oil:
SAE10W-30 API:SH/CD

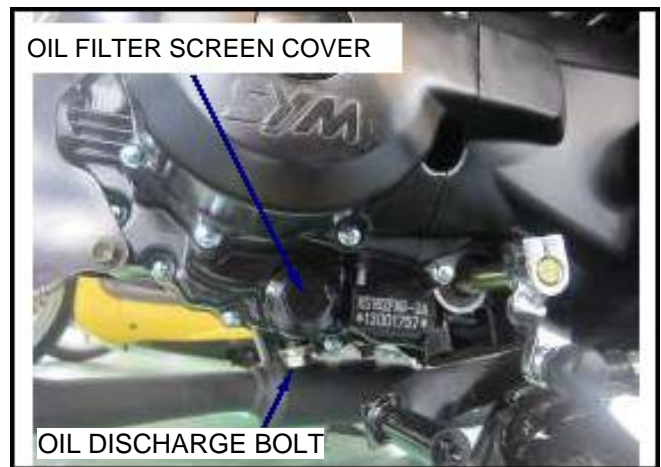

OIL FILTER SCREEN CLEANING

Remove the oil filter cover, oil filter screen and drain the engine oil.

Clean the oil filter screen with compressed air.

Install the oil filter screen, spring and screen cap.

Fill the crankcase with the recommended oil.

Oil capacity:1.0 liter(0.85 liter for change)

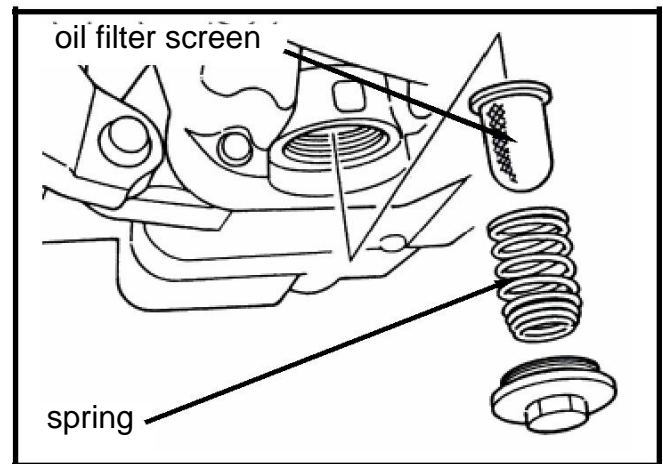
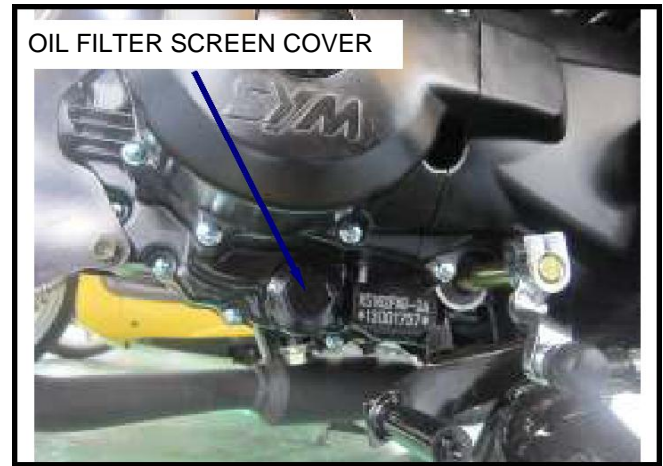

SPARK PLUG

Disconnect the spark plug cap and remove the spark plug .

Visually inspect the spark plug electrodes for wear. The center electrode should have square edges and side electrode should have a constant thickness.

Discard the spark plug if there is apparent wear or if the insulator is cracked and/or chipped .If the spark plug deposits can be removed by sandblasting or wire brushing,the spark plug can be reused.

Inspect the gap with a feeler gauge and adjust by bending the side electrode.

Standard gap:0.6-0.7mm

NOTE:

To install turn finger tight then tighten with a spark plug wrench.

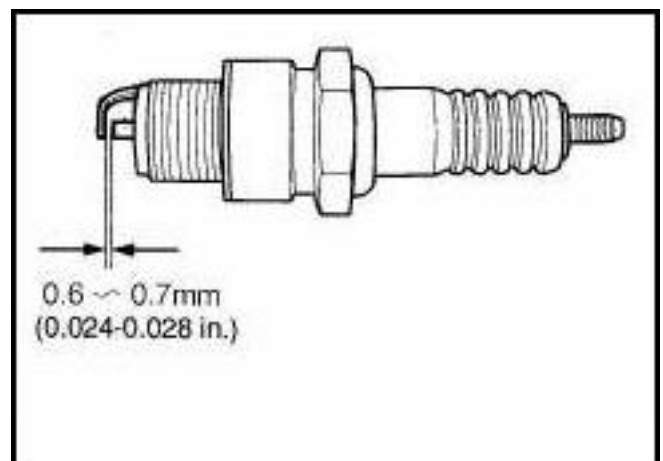

COMPRESSION TEST

Warm up the engine.

Stop the engine .Remove spark plug .Insert the compression gauge.

Push in the choke lever .Open the throttle grip fully.

Electrical start engine several times.

NOTE:

Watch for compression leaking at the gauge connection.

Crank the engine until the gauge reading stops rising .The maximum reading is usually reached in several times.

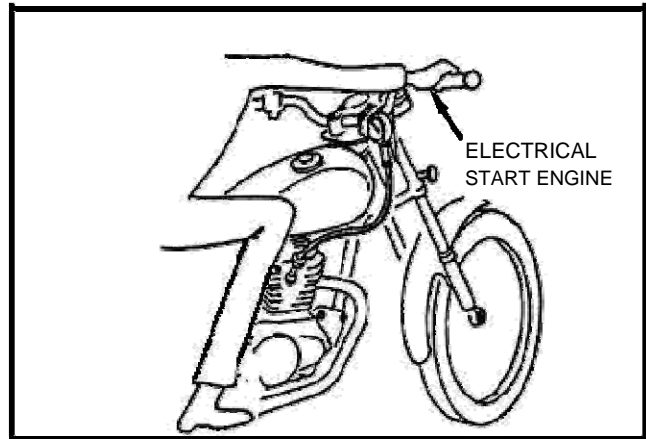

Compression: $9.5\text{kg/c m}^2 \pm 1\text{kg/c m}^2$

Low compression can be caused by:

Improper calve adjustment.

Valve leakage .

Blown cylinder head gasket.

Worn piston rings or cylinder.

Worn piston.

High compression can be caused by:

Carbon deposits in combustion chamber or on piston head.

2.INSPECTION/ADJUSTMENT



VALVE CLEARANCE

NOTE:

Inspect and adjust the valve clearance while the engine is cold.

Remove the timing inspection hole cap and crankshaft hole cap.

Rotate the generator rotor counterclockwise and align the "T" mark on the generator rotor with the index mark in the left crankcase

(piston must be at T.D.C.of the compression stroke).

Inspect the intake and exhaust valve clearance by inserting a feeler gauge between the adjusting screw and valve stem, valve clearance:

Intake: 0.05mm(125c.c)

Exhaust: 0.15mm(125c.c.)

Adjust by loosening the lock nut and turning the adjusting screw until there is a slight drag in the feeler gauge.

NOTE:

Inspect the valve clearance again after tightened the lock nut.

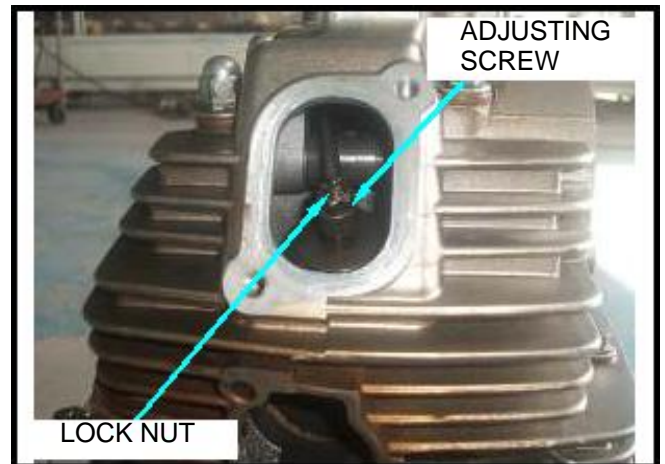

2.INSPECTION/ADJUSTMENT



Install the valve adjuster caps and generator cap.
NOTE:

Check the O-ring for damage and spread oil before installing the caps.

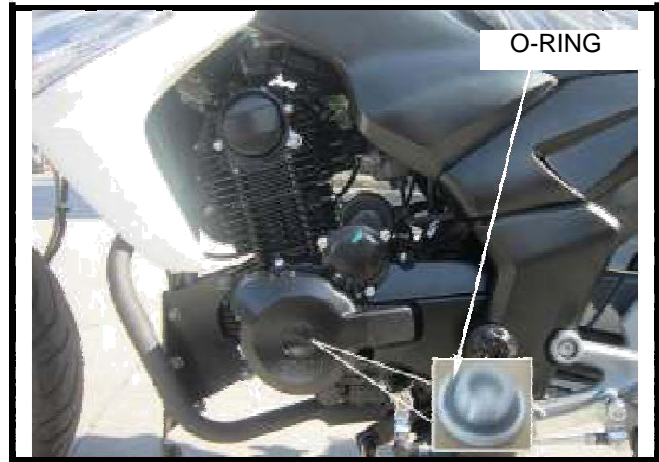

CAM CHAIN TENSIONER ADJUSTER

The cam chain tension is kept by the tensioner push rod that is compressed by the spring.

CAUTION:

If remove any parts that is related with the cam chain ,remove the cam chain tensioner adjuster first.



CARBURETOR THROTTLE GRIP FREE PLAY

Check throttle grip free play.
Free play:2-6mm

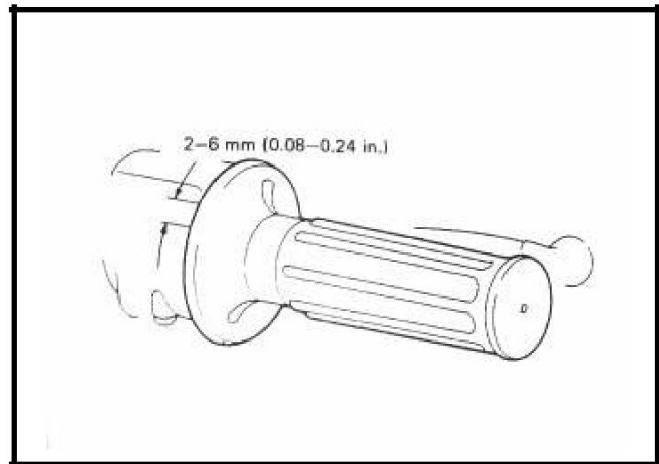

THROTTLE GRIP ADJUSTMENT

Loosen the lock nut and turn the adjuster to adjust.



AIR CLEANER

Remove the seat.
Remove the air cleaner cover.
Remove the air cleaner element.

NOTE:

Clean the cleaner element periodically.(Refer to maintenance schedule.)



Assemble air cleaner element in reverse order of disassemble.

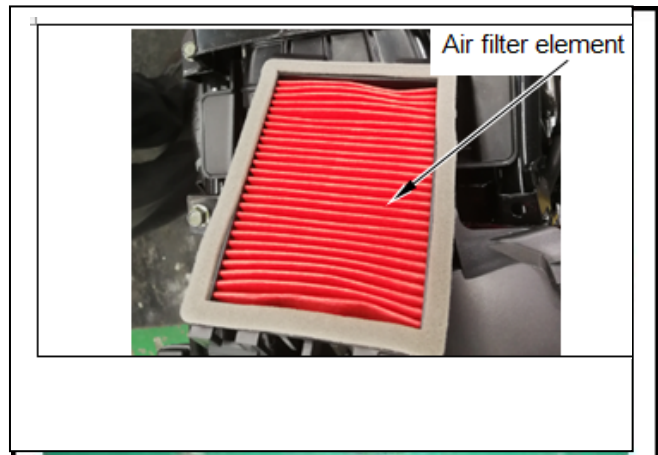

CLUTCH ADJUSTMENT

CLUTCH LEVER FREE PLAY

Measure the clutch free play at the tip of the clutch lever.
Free play :10-20mm

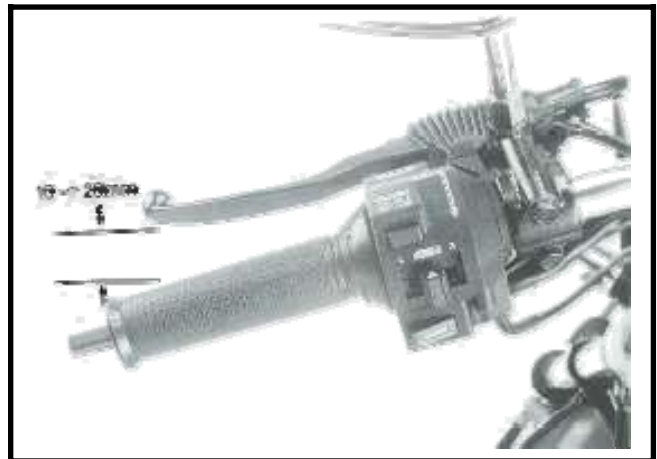

FREE PLAY ADJUSTMENT

Loosen the lock nut and turn the adjuster.
Turn the adjuster ,clockwise for decreasing the free play ,counterclockwise for increasing the free play.

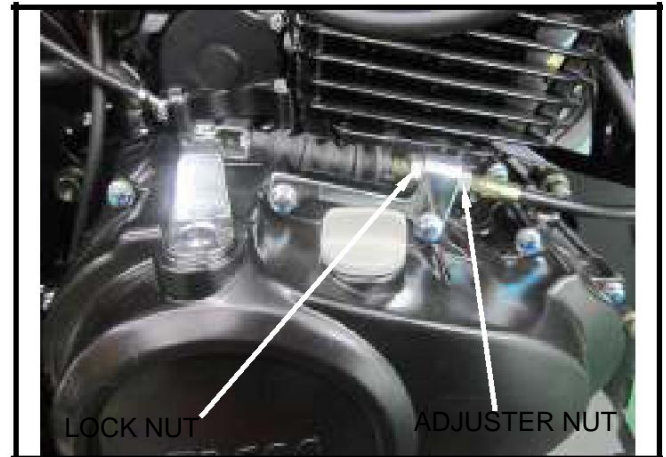

BRAKE ADJUSTMENT

FRONT BRAKE LEVER FREE PLAY

Measure the brake free play at the tip of the brake lever.

Free play:10-20mm



BRAKE PAD WEAR INSPECTION

Check for brake pad wear by operating the brake lever.
Check the brake pads for wear by looking through the slot indicated by the arrow cast on the caliper assembly.

Replace the brake pads if the wear line on the pads reaches the edge of the brake disc.



REAR BRAKE PEDAL FREE PLAY

Measure the brake pedal free play before the brake start to engage.

Free play :20-30mm

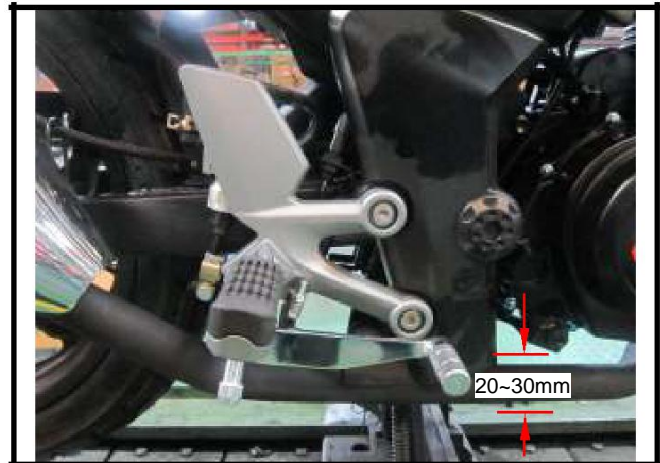

DRIVE CHAIN ADJUSTMENT

Place the motorcycle on its main stand and shift the transmission into neutral.

Remove chain cap and check the drive chain slack by moving up and down with the fingers. Chain slack:10-20mm

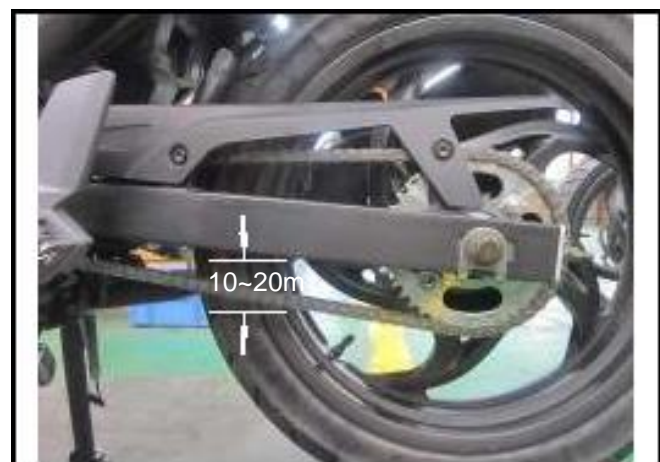

2.INSPECTION/ADJUSTMENT



Loose the rear wheel axle nut for adjusting.
Turn the adjusting nuts on both adjusters
as necessary.

CAUTION:

Tighten the axle nut.

TORQUE:10.00-12.00 kgf·m

Recheck the drive chain slack and free wheel rotation.
Lubricate the drive chain with chain lubricant.



WHEEL/RIM

Stand the motorcycle,check the tires for
cuts,imbedded nails,or other sharp objects. Check the
tire pressure.

Cold tire	One rider	Front	1.75 kg/c m ²
		Rear	2.00 kg/c m ²
	Two riders pressure	Front	2.00 kg/c m ²
		Rear	2.25 kg/c m ²
Max.load		120kg	
Tire size		Front	110/70-17
		Rear	130/70-17
Minimum depth of tread		Front	1.5mm
		Rear	2.0mm

SUSPENSION

FRONT SUSPENSION

Check the action of the front forks by compressing them several times with the front brake applied .

If there are abnormal noises or rattles ,check all the fasteners and tighten them to the specified torque. TORQUE:

Front fork top bridge bolt(Front fork upper lock nut) :3.00-3.50 kgf · m

Front fork bottom bridge bolt(Front fork lower lock nut):2.40-3.00 kgf.m

Front wheel axle nut:6.00-8.00 kgf.m

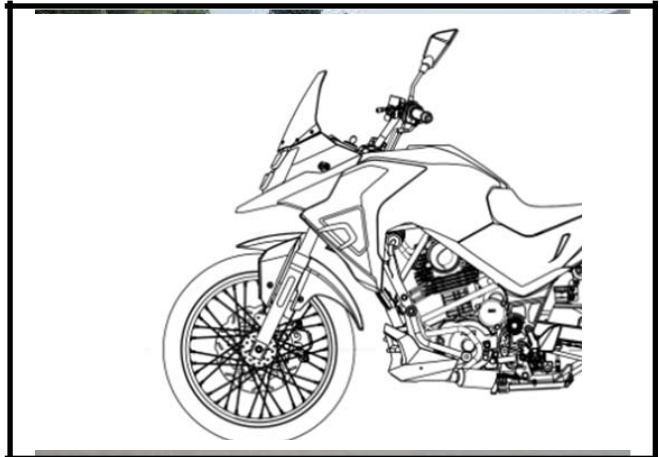

REAR SUSPENSION

Check for abnormal noises and leaks by compressing the rear suspension several times.

Move the rear wheel side ways with force to see if the swing arm bushings are worn.

Rear cushion upper bolt torque:3.5-4.5 kgf.m

Rear cushion lower bolt torque:3.5-4.5 kgf.m



STEERING

Raise the front wheel off the ground and check that the handlebar rotates freely.If the handlebar moves unevenly ,binds or has vertical movement,adjust the steering head nut.



BATTERY

Inspect the battery fluid level ,if the fluid level nears the lower level mark,fill with distilled water to the upper level mark .

Clean the battery terminals with warm water.
Check the specific gravity of the battery electrolyte.(13-3)

NOTE:

Do not overfill. Add only distilled water. Tap water will shorten the service life of the battery.

WARNING:

Keep the electrolyte away from eyes ,skin and clothes. If touched it ,wash them with clean water quickly.



HEADLIGHT AIM

Adjust vertically by turning headlight up and down with the headlight bolts loosening. Fasten the bolts after adjustment.

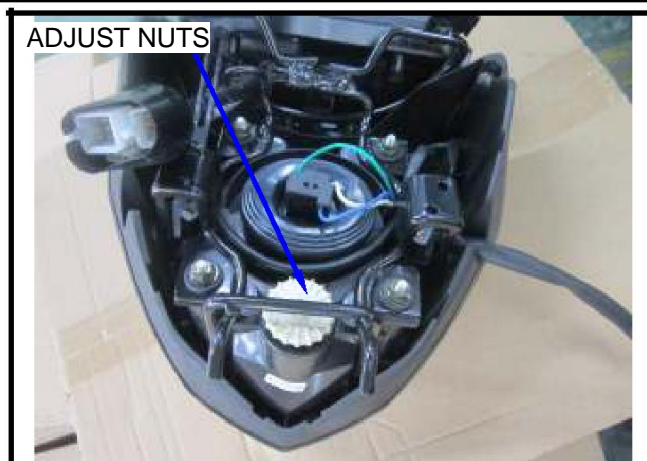

STOPLIGHT SWITCH

The stoplight should come on when the brake pedal is depressed 20mm from the standard pedal position. If the action is abnormal, adjust by turning the stoplight switch adjusting nut.

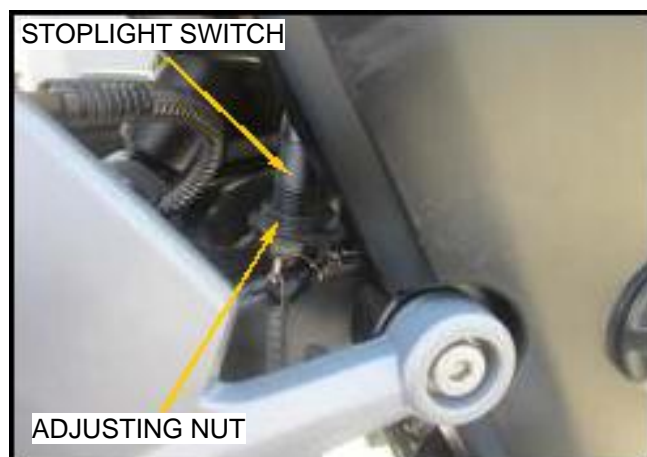

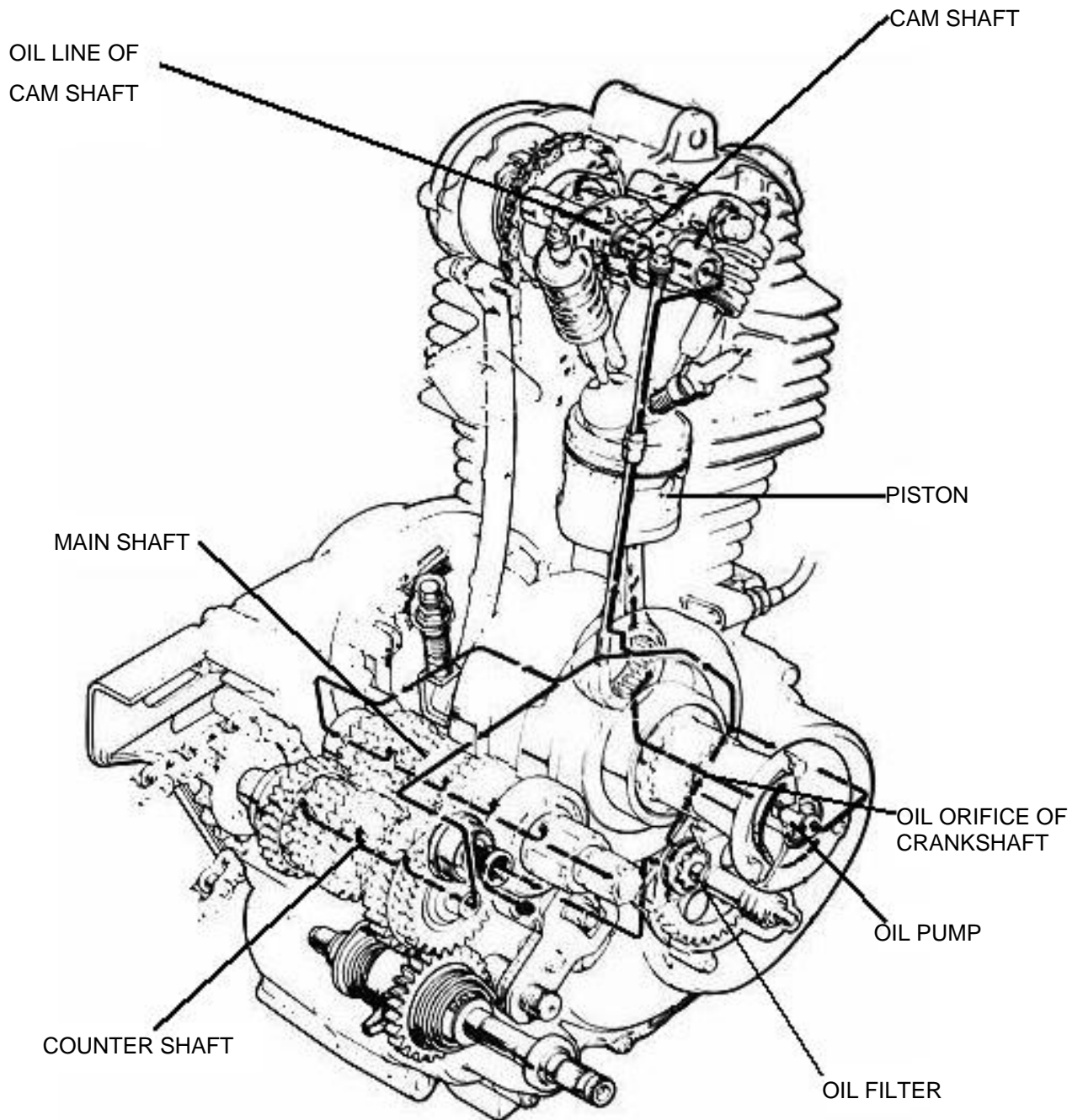

.....TROUBLESHOOTING 3-1SERVICEINFORMATION 3-1
--------------------------	-----------------------------

TROUBLE SHOOTING

OIL LEVEL TOO LOW

1. Natural consumption
2. Oil leaks
3. Worn piston rings

OIL CONTAMINATION

1. Oil not changed often enough
2. Faulty cylinder head gasket

OIL PRESSURE TOO LOW

1. Oil filter clogged
2. Oil pump damaged

OIL PRESSURE TOO HIGH

1. Oil filter or line clogged
2. Oil not recommended

NO OIL PRESSURE

1. Oil level too low
2. Oil pump damaged

SERVICE INFORMATION

NOTICE:

Inspection and service of oil pump can be serviced with the engine installed on the frame.

Oil pump service --- 7-9

Oil filter cleaning --- 2-4 ~ 2-5

SPECIFICATIONS

Oil capacity	1.0 liter(0.85 liter for change)
Oil recommended	SAE 10W-30 API:SH/CD
Oil pump delivery	3.5 liter above / min. / 4600rpm

.....SERVICEINFORMATION 4-1 ENGINE REMOVAL 4-2ENGINEINSTALLATION 4-4
---	-----------------------------

SERVICE INFORMATION

GENERAL INSTRUCTIONS

The following parts can be serviced with the engine installed on the frame:

- Generator
- Clutch
- Oil pump
- Cam shaft / Rocker arm
- Shift spindle
- Cam chain tensioner

The following parts must be serviced with the engine removed off the frame:

- Cylinder head
- Cylinder
- Piston
- Crankshaft
- Transmission

During removal and installation, jack or adjustable support is required to maneuver the engine.

TORQUE VALUES

Engine hanger 8mm bolt / nut	2.40-3.00 kgf · m
Engine hanger 10mm bolt / nut	4.50-5.50 kgf · m
Drain bolt	1.50-2.50 kgf · m
Gearshift pedal bolt	0.80-1.20 kgf · m

ENGINE REMOVAL

Drain the engine oil.

Disconnect the fuel tubes and all connect tubes. In order to avoid the gasoline leak, clamp tubing with clip firstly.

Remove the right and left side covers.



Remove the gear change pedal and left crank case rear cover.



Disconnect the A.C. generator wire of the connector and remove the generator wire.

Remove the wire clamp screw and clamp.

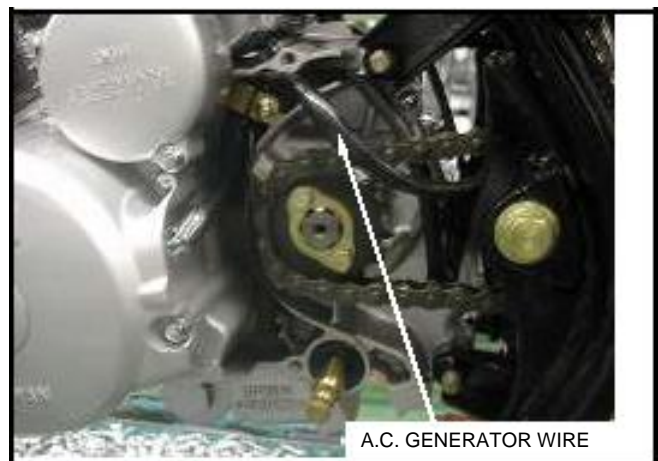

4.ENGINE REMOVAL/INSTALLATION



Remove the clutch cable.
Remove the spark plug cap.
Remove the exhaust muffler.



Remove left side cover.
Loosen ECU connecting.
Separate the carburetor pipe and the cylinder head by removing the attaching bolts. Remove the crankcase breather tube.

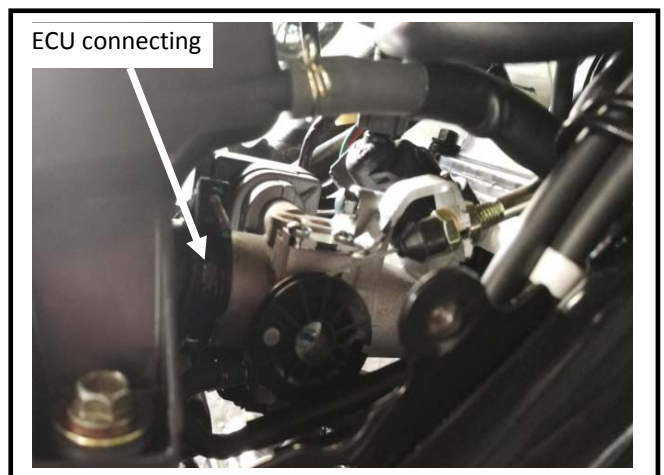

Loosen the rear wheel axle nut.
Loosen the drive chain adjusting nut and push the rear wheel forward.
Remove the drive chain clip, and remove the drive chain.

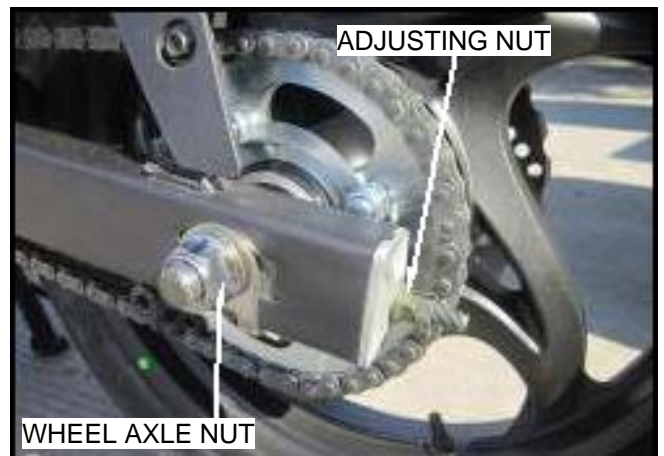

4.ENGINE REMOVAL/INSTALLATION



Remove the front engine hanger bolt.

NOTE:

Places jack or padded block under the engine before removing the front engine hanger.

Disconnect the starter motor wire.



Remove the 10mm bolts of the rear engine hanger.



Remove the engine.

NOTE:

Prevent damage to wire harnesses and cables during operation.

ENGINE INSTALLATION

Follow the reverse procedure of removal to install the engine.

Notice the following items during installation:

Route all wire harnesses and cables properly.

Adjust the throttle grip free play (P2-10)

Adjust the clutch lever free play (P2-12)

Adjust the drive chain slack (P2-14)

Fill the crankcase with the recommended grade oil to the proper level.

SAE 15W-40 API: SH / CD



TROUBLE SHOOTING.....	5-1	VALVE GUIDE REPLACEMENT.....	5-8
SERVICE INFORMATION.....	5-2	VALVE SEAT INSPECTION/REFACING ...	5-9
CAM SHAFT REMOVAL	5-3	VALVE SEAT GRINDING.....	5-10
CYLINDER HEAD/ROCKER ARM REMOVAL	5-4	CYLINDER HEAD ASSEMBLY	5-13
CYLINDER HEAD DISASSEMBLY	5-6	CYLINDER HEAD INSTALLATION....	5-14
VALVE/VALVE GUIDE INSPECTION.....	5-7	CAM SHAFT INSTALLATION	5-15

TROUBLE SHOOTING

LOW COMPRESSION

1. Valve

- Incorrect valve clearance
- Burned or bent valves
- Incorrect valve timing
- Broken valve spring

2. Cylinder head

- Leaking or damaged head gasket
- Warped or cranked cylinder head

HIGH COMPRESSION

- Excessive carbon buildup on piston or combustion chamber.

ABNORMAL NOISE

- Incorrect valve clearance
- Broken valve spring
- Worn rocker arm or camshaft
- Loose or worn cam chain
- Worn cam chain tensioner
- Worn cam sprocket teeth

SERVICE INFORMATION

GENERAL INSTRUCTIONS

Camshaft, rocker arm shaft and rocker arm can be serviced with the engine installed on the frame.

Camshaft lubrication oil is fed to the cylinder head through an oil control orifice in the engine case.

Be sure this orifice is not clogged and the O-ring and dowel pins are in place before installing the cylinder head.

During assembly, apply molybdenum disulfide grease to the camshaft bearings, and pour clean engine oil into the cylinder head.

TORQUE VALUES

Cylinder head bolt	2.80-3.00 kgf.m
Cylinder head side flange bolt	0.80 –1.20 kgf.m
Cam chain setting plate flange bolt	0.80-1.20 kgf.m

SPECIFICATIONS

ITEM			STANDARD SERVICE	LIMIT
Camshaft	Cam lift	IN	31.377mm	30.245mm below
		EX	31.071mm	29.96mmbelow
	Runout			0.02mm
Rocker arm I.D.		I.D.	12.000 ~ 12.018mm	12.018mm above
Rocker arm shaft		O.D.	11.966 ~ 11.984 mm	11.966mm below
Valve spring	Free length		Outer:40.9mm	39.0mm below
			Inner:33.5mm	32.0mm below
	Stall length		Outer: →35.4mm 15.6 ± 1.2kgf →27.9mm 47.4 ± 2.3 kgf	
			Inner: →30.7mm 7.1 ± 0.4kgf →23.2mm 26.0 ± 1.5kgf	
Valve clearance			125c.c. Intake valve:0.05mm Exhaust valve:0.15mm	
			165c.c. Intake valve:0.05mm Exhaust valve:0.15mm	
Valve guide	O.D.	IN	5.447 ~ 5.462mm	5.41mm
		EX	5.430 ~ 5.455mm	5.40mm
	Guide I.D.	IN	5.475 ~ 5.485mm	5.50mm
		EX	5.475 ~ 5.485mm	5.50mm
	Stem to guide Clearance	IN	0.013 ~ 0.038mm	0.08mm
		EX	0.03 ~ 0.055mm	0.10mm
Valve seat width			1.40 ~ 1.80mm	2.00mm

CAMSHAFT REMOVAL

NOTE:

The camshaft, rocker arm and rocker arm shaft can be serviced with the engine installed on the frame.

Remove the cam sprocket cover.



Remove the crankshaft hole cap and the timing inspection hole cap.

Rotate the generator rotor counterclockwise and locate the piston at the T.D.C. of the compressing stroke.

Remove the cam sprocket bolts and remove the cam sprocket.

NOTE:

Take care not to drop then bolt into the crankcase.



Suspend the cam chain with a wire to prevent it from falling into the crankcase.

Remove the camshaft.



CYLINDER HEAD

REMOVAL

- Remove the cam chain tensioner bolt.
- Remove the 8mm bolt.
- Remove the 4 cylinder head nuts.
- Remove the dowel pins.
- Remove cam chain tensioner.
- Remove the cylinder head.

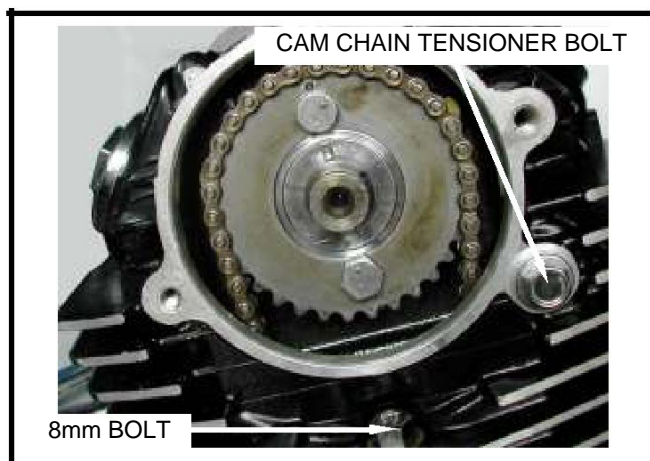

Remove the rocker arm shaft.



Remove the rocker arms.

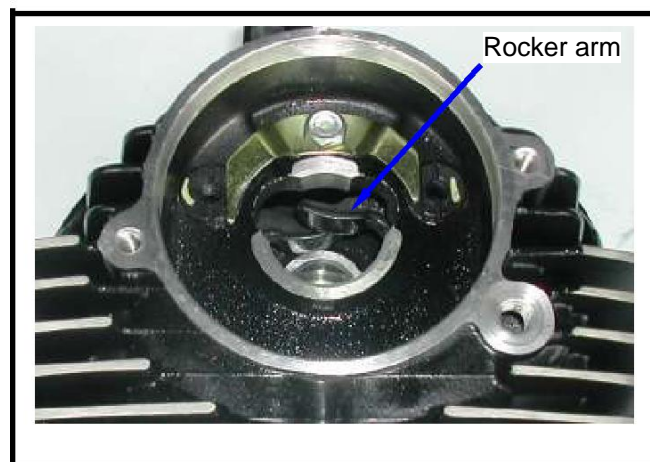

CAMSHAFT INSPECTION

Inspect the cams of the camshaft for wear.

Service limit:

Inlet: 30.25mm
Exhaust: 29.96mm

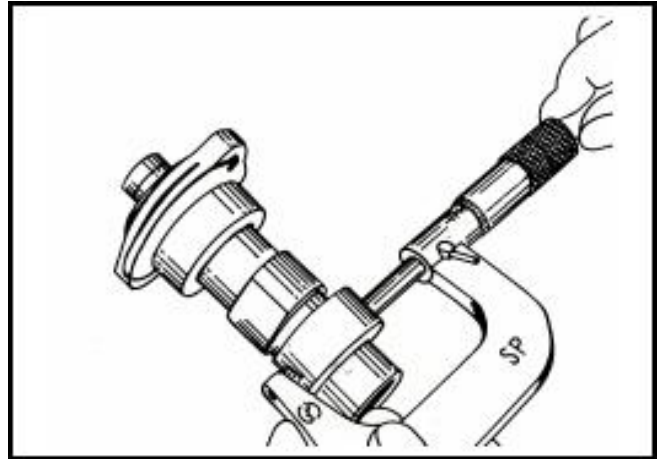

ROCKER ARM INSPECTION

Inspect the rocker arm I.D. and the rocker arm for wear, damage or clogged oil holes. Rocker arm I.D.

Service limit: ϕ 12.018mm

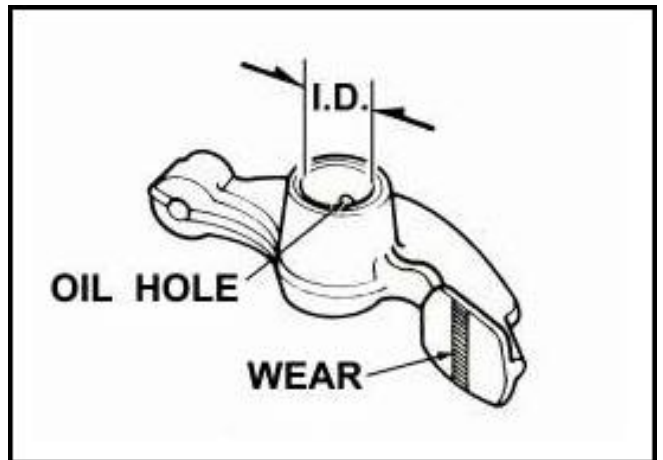

ROCKER ARM SHAFT INSPECTION

Inspect rocker arm shaft for wear or damage.

Rocker arm shaft O.D.

Service limit : ϕ 11.966mm

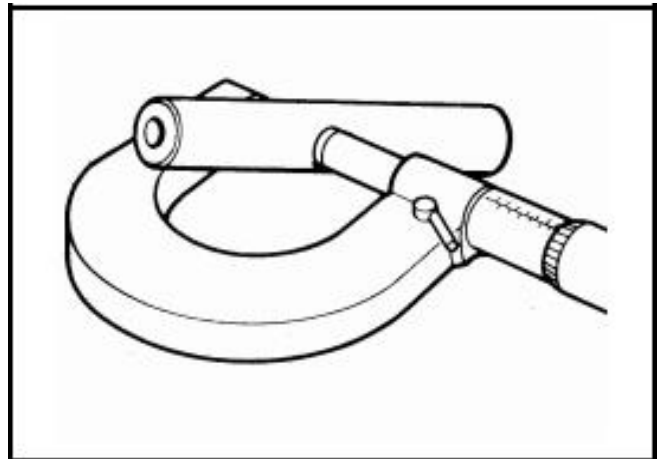

CYLINDER HEAD DISASSEMBLY

Remove carbon deposits from the combustion chamber. Remove valve spring and valve spring and valve with a valve spring compressor.

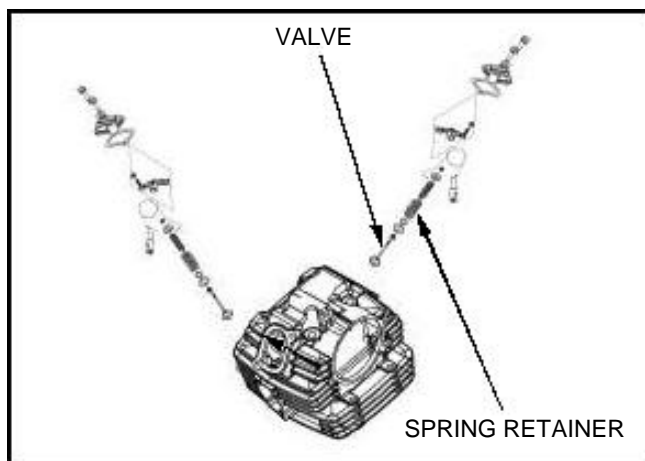

CYLINDER HEAD INSPECTION

Remove gasket from cylinder head with a scraper.
Check the cylinder head for crack.
Check the cylinder head for warpage with a straight edge and a feeler gauge.
Service limit: 0.10mm

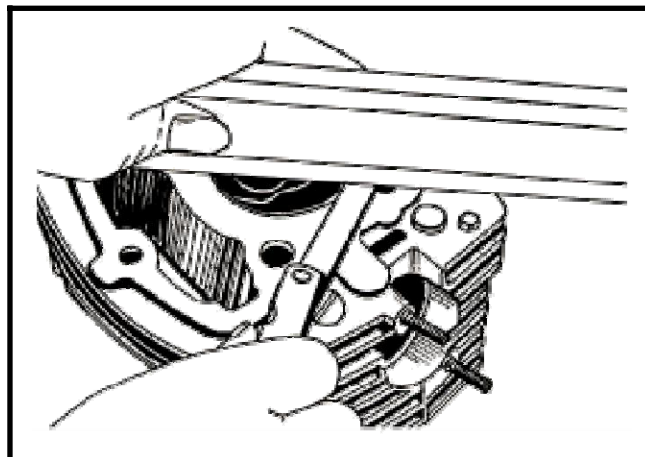

VALVE SPRING INSPECTION

Measure the free length of the inner and outer valve spring.

Service limit:

Out spring:39.0 mm below

Inner spring:32.0 mm below

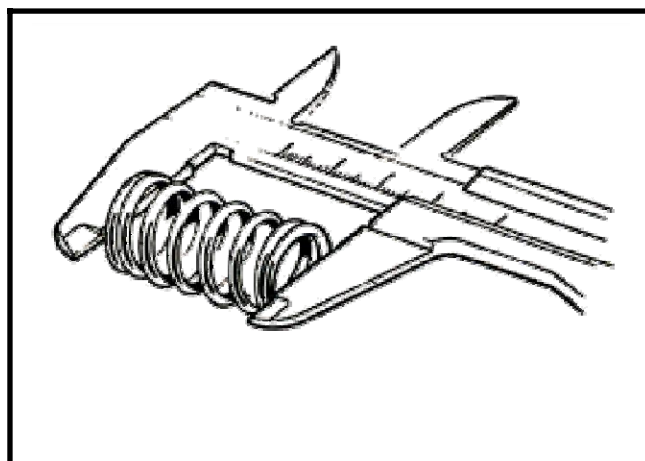

VALVE/VALVE GUIDE

INSPECTION

Inspect valves for scratches, burning or wear.
Check the valve movement in the guide.
Measure the valve stem O.D. Service limit:

Intake: \varnothing 5.41mm
Exhaust: \varnothing 5.40mm

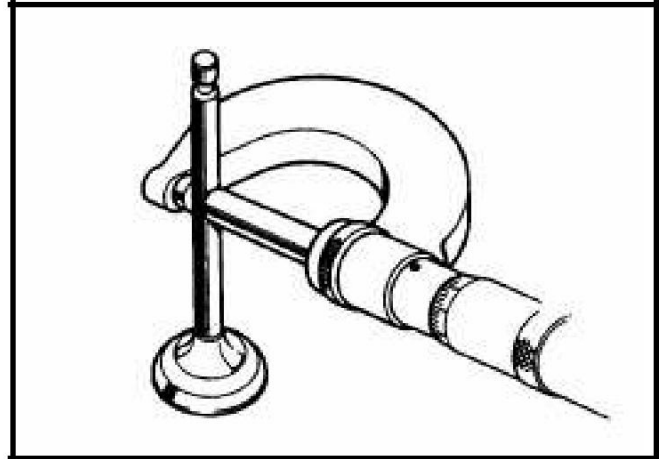

NOTE:

Remove any carbon buildup before checking the valve guide I.D.

Guide I.D. service limit

Intake: \varnothing 5.50mm
Exhaust : \varnothing 5.50mm

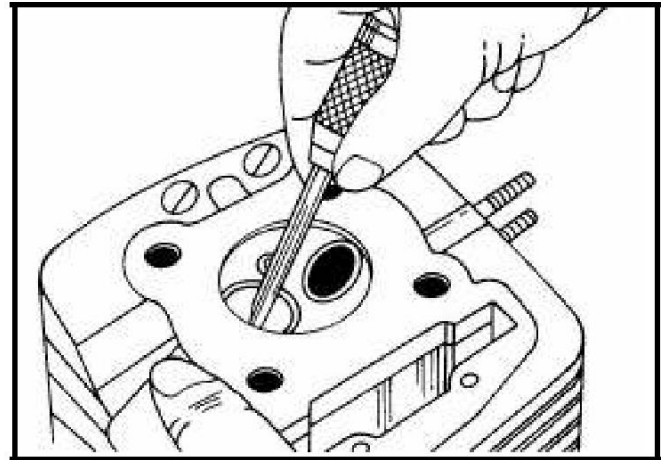

Measure the valve guide I.D. and calculate the stem to guide clearance.

Service limit:

Intake: 0.08mm
Exhaust: 0.10mm

If the stem to guide clearance exceeds the service limit, replace the valve or guide to fit.

NOTE:

The guide must be reamed when replacing a new one.

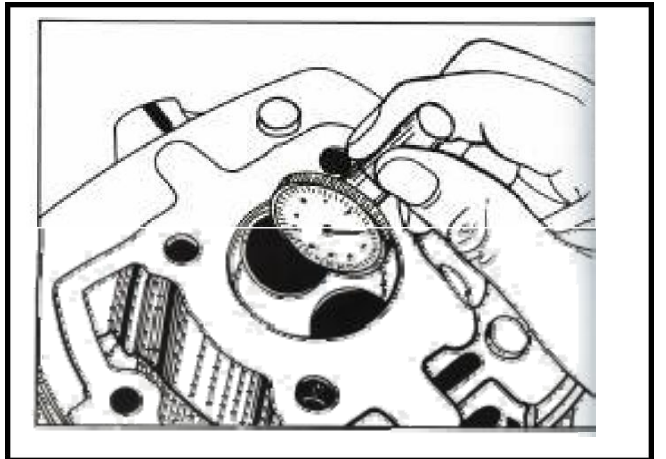

VALVE GUIDE REPLACEMENT

Drive out the valve guide from the combustion chamber side with a 5mm valve guide remover.

NOTE:

When driving out the valve guide, do not damage the cylinder head.

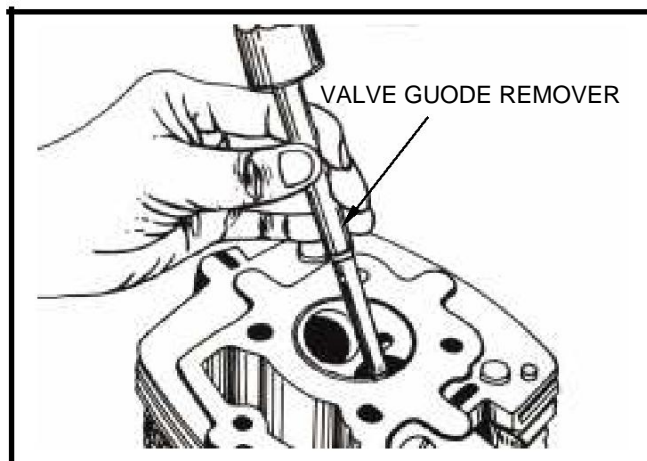

Install the new valve guide from the top of the cylinder head, and ream it with a reamer, then clean the cylinder head.

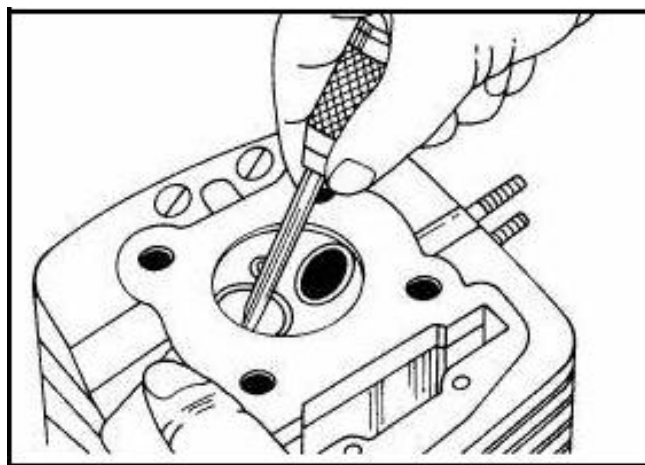

5. CYLINDER HEAD/ VALVE



VALVE SEAT INSPECTION/ REFACING

Clean intake and exhaust valves to remove carbon deposits.

Apply a light coating of prussian blue to each valve face.

Insert each valve into the guide and rotate them two cycles.

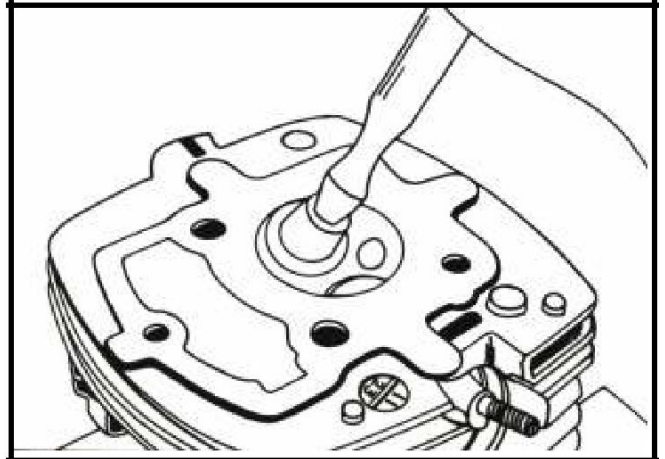

Remove the valve and inspect the face.

CAUTION:

If the valve face is burned or damaged or unevenly, replace the valve.

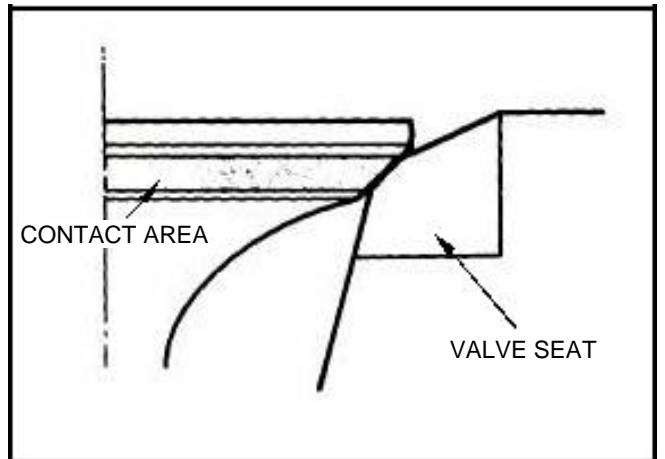

Inspect the valve seat.

If the seat is too wide or too narrow, the seat must be refinished.

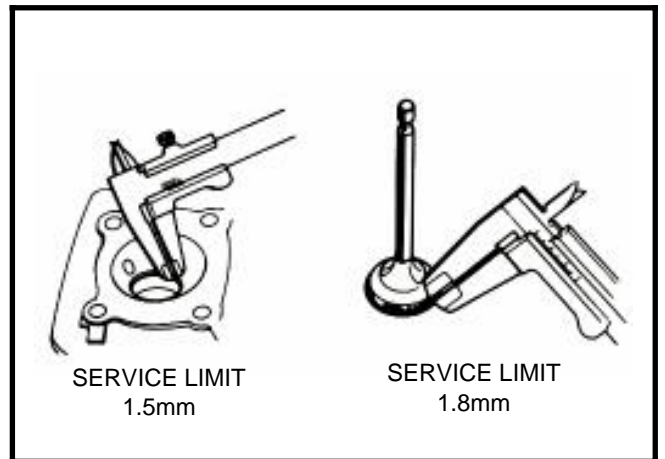

VALVE SEAT GRINDING

NOTE:

Follow the instructions described in the cutter instruction manual.

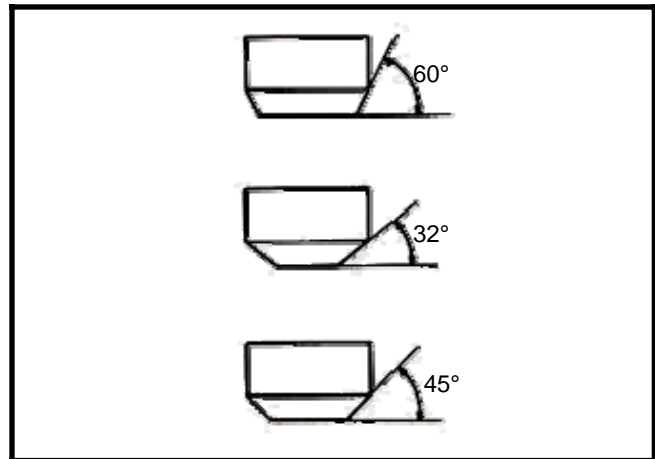

Remove any roughness from the seat by applying 4~5 kg pressure, turning the cutter left and right.

NOTE:

Add engine oil to the face when operating.

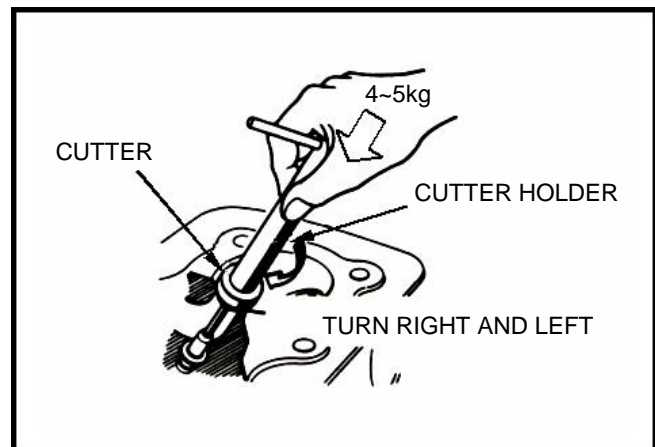

Using a 45 degree cutter,remove any roughness from the seat.

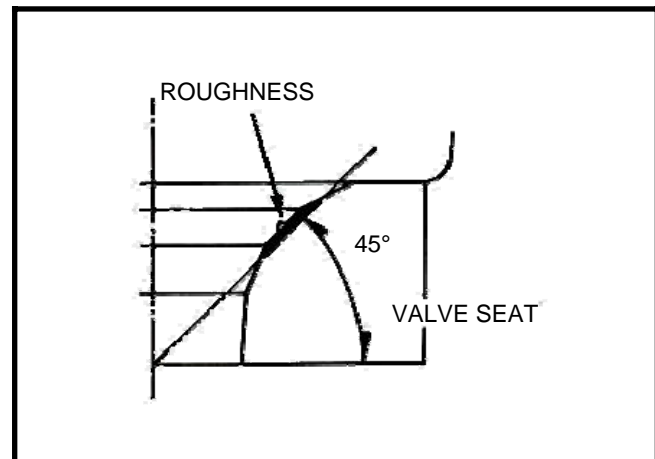

5. CYLINDER HEAD/ VALVE

Using a 32 degree cutter, remove 1/4 of the existing valve seat material.

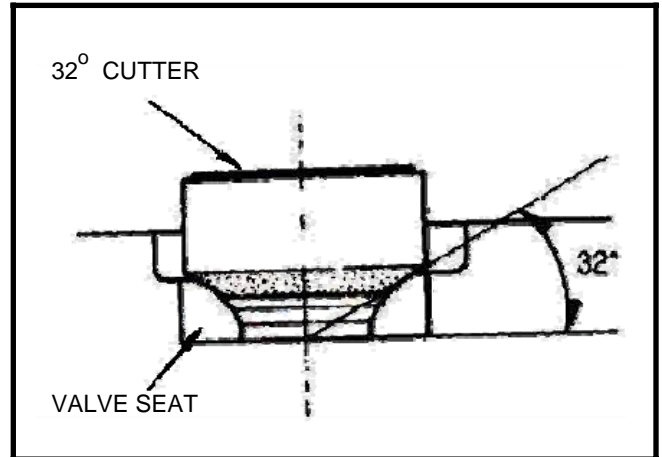

Remove the bottom 1/4 of the old seat by using a 60 degree cutter.

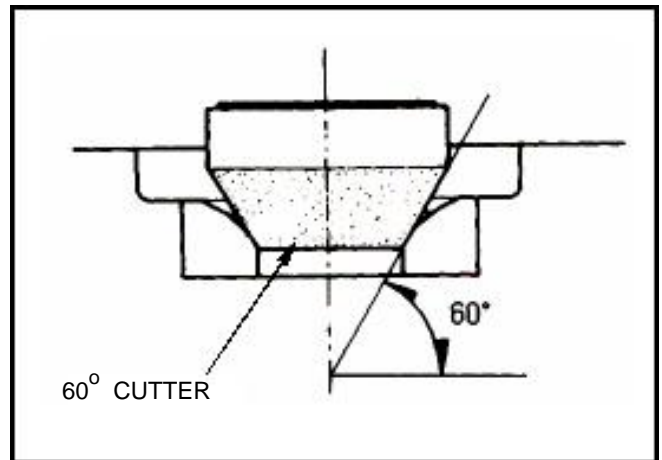

Finish the seat to the proper width by using a 45 degree cutter.

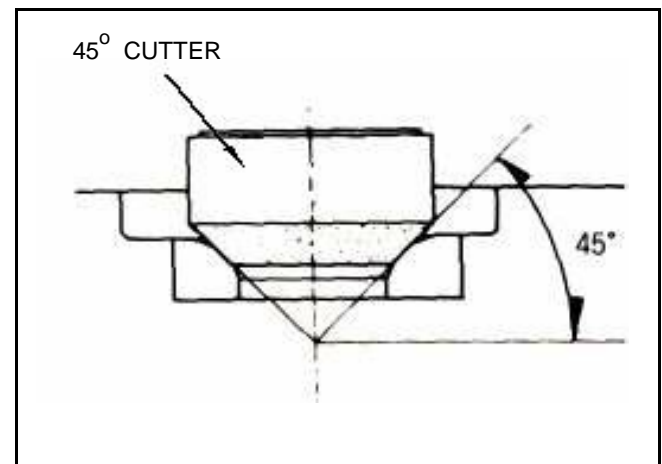

If the contact area is too high on the valve, the seat must be lowered using a 37.5 degree cutter, then finish with a 45 degree cutter.

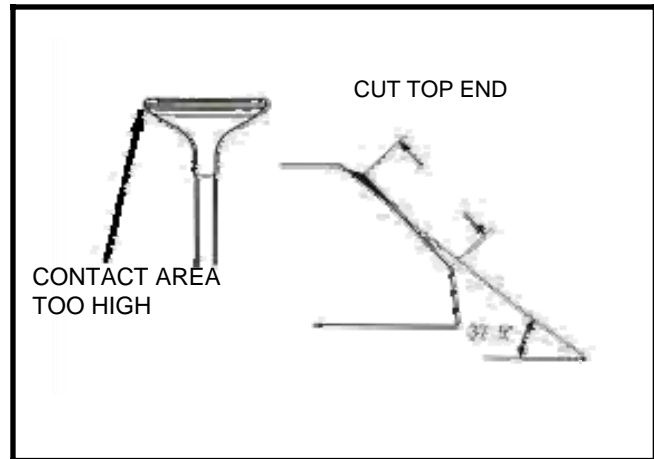

If the contact area is too low on the valve, the seat must be raised using a 63.5 degree cutter, then finish with a 45 degree cutter.

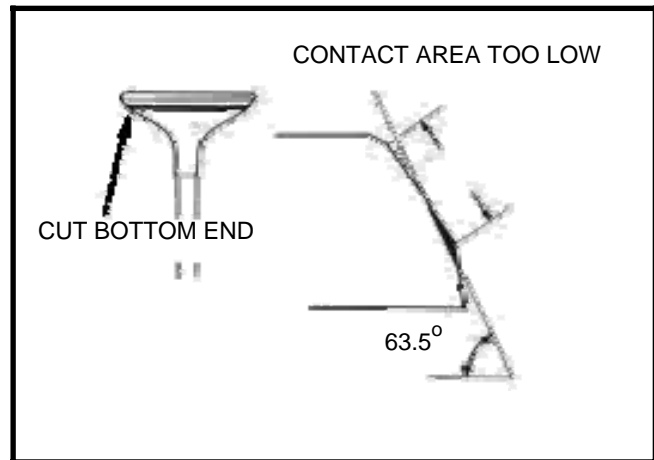

After cutting the seat, apply lapping compound to the valve face, and lap the valve using light pressure.

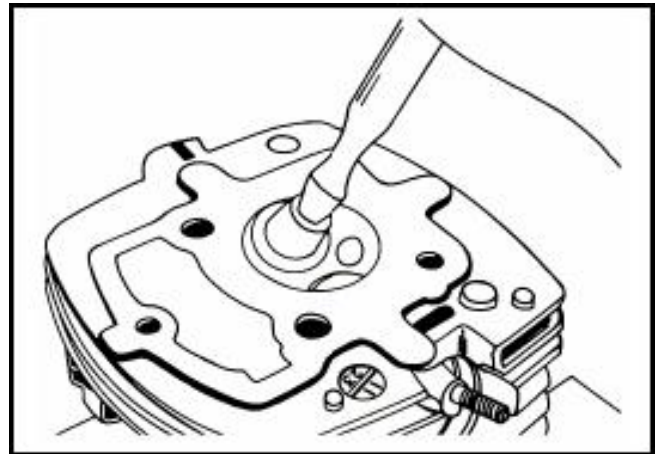

CYLINDER HEAD ASSEMBLY

Compress the valve springs with a valve spring compressor and install the valve cotters into the valve retainer.

CAUTION:

Do not compress the valve spring more than necessary.

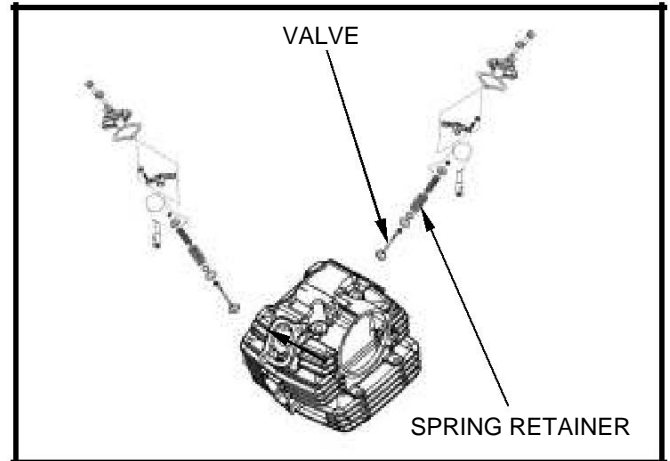

NOTE:

Install a new valve stem seal when assembling.

Lubricate each valve stem with the engine oil then insert them into the guides.
Install the valve spring and retainers.

NOTE:

Install the valve springs with the tightly wound coils facing the cylinder head.



Tap the valve stems gently with a plastic hammer to firmly seat the cotters.



CYLINDER HEAD INSTALLATION CAMSHAFT AND CAMSPROCKET ASSEMBLY

NOTE:

Rocker arms must be installed at the right position.

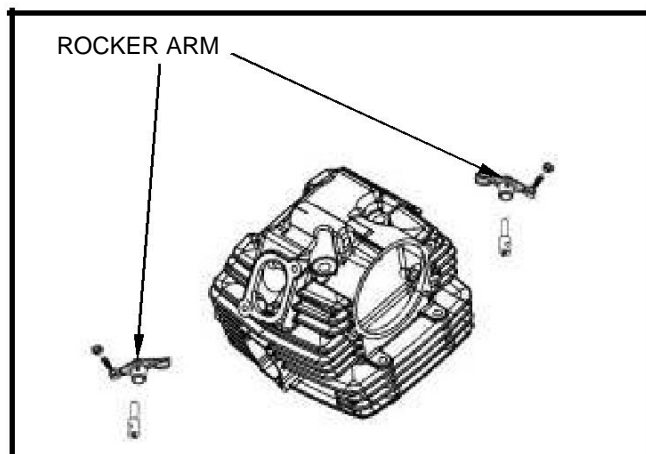

Clean the cylinder head gasket surface of any gasket material.

Install the new gasket, O-ring and dowel pins and chain guide.

NOTE:

Do not allow dust and dirt to enter the cylinder.



Install the cylinder head.

NOTE:

Support the cam chain to keep it from falling into the crankcase.

Install the cam chain tensioner set and bolt and washer.

Install dowel pins.

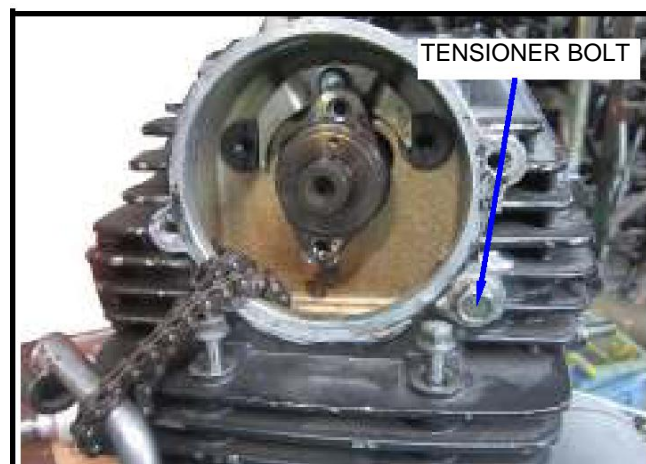

5. CYLINDER HEAD/ VALVE



CAM SHAFT INSTALLATION

Rotate the generator rotor and align the "T" mark with the index mark.

Install the camshaft comp.

When installing camshaft set, please take care that the line on the camsprocket should be in parallel with the surface of cylinder head. (The IN/EX cam should be faced down).

Install the camshaft holder.

Install the cylinder head nuts.

TORQUE: 2.80 ~ 3.00 kgf.m

CAUTION:

The cap nut of the four holder nuts must be installed at the left-front side.

Install the 6mm bolts.

Install the cam chain chain tensioner.

Install the auto-tensioner. (Lock the spring cap bolt first.)

Release the auto-tensioner lock bolt.

Adjust the valve clearance. (2-7)

Install the cylinder head cover.

Install the R/L cylinder head side cover.

Install the 6mm special bolts.

NOTE:

If the cylinder head side cover gasket is damaged or broken, replace with a new one.

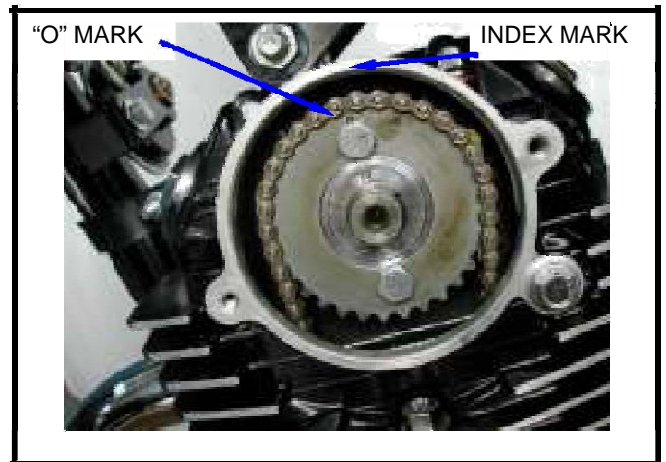

TROUBLE SHOOTING.....	6-1PISTON/PISTONRINGINSPECTION	6-3
SERVICE INFORMATION.....	6-1	PISTON RING INSTALLATION.....	6-5
CYLINDER REMOVAL.....	6-2	PISTON INSTALLATION.....	6-6
PISTON REMOVAL.....	6-3	CYLINDER INSTALLATION.....	6-6

TROUBLE SHOOTING

LOW COMPRESSION

1. Worn cylinder or piston rings.

EXCESSIVE SMOKE

1. Worn cylinder, piston or piston rings.
2. Improper installation of piston rings.
3. Scored or scratched piston or cylinder wall.

OVERHEATING

1. Excessive carbon build-up on piston or combustion chamber wall.

KNOCKING OR ABNORMAL NOISE

1. Worn piston or cylinder.
2. Excessive carbon build-up

SERVICE INFORMATION

GENERAL STRUCTIONS

ITEM		MG12B1-EU		
		STANDARD SERVICE	LIMIT	
	Cylinder	Runout	56.495 ~ 56.515mm(125c.c.)	56.52mm
		Taper	0.05mm	0.05mm
			0.05mm	0.05mm
Piston groove clearance	Piston ring to ring groove clearance	Top	0.025 ~ 0.055mm	0.060mm
		Second	0.015 ~ 0.040mm	0.045mm
	Piston ring End gap	Top	0.10 ~ 0.25mm	0.5mm
		Second	0.25 ~ 0.45mm	0.7mm
		Oil ring	0.20 ~ 0.70mm	
	Piston O.D.	56.485 ~ 56.505mm(125c.c.)		56.48mm
		Piston pin bore	15.002 ~ 15.008mm	15.05mm
	Connecting rod small end I.D.		15.000 ~ 15.018mm	15.05mm
	Piston pin O.D.		14.994 ~ 15.000mm	14.994mm
	Piston ring thickness	Top	0.97 ~ 0.99mm	
Second		0.97 ~ 0.99mm		
Cylinder to piston clearnace		0.025 ~ 0.035mm(125c.c.)	0.2mm	

CYLINDER REMOVAL

Remove the cylinder head.
 Remove the dowel pins and gasket.
 Remove the cylinder.

NOTE:

Avoid the dowel pins falling into the crankcase during removing the cylinder.



Remove the dowel pins and gasket.



Clean the cylinder gasket surface of any gasket material.

NOTE:

Avoid damaging the cylinder gasket surface during this operation.

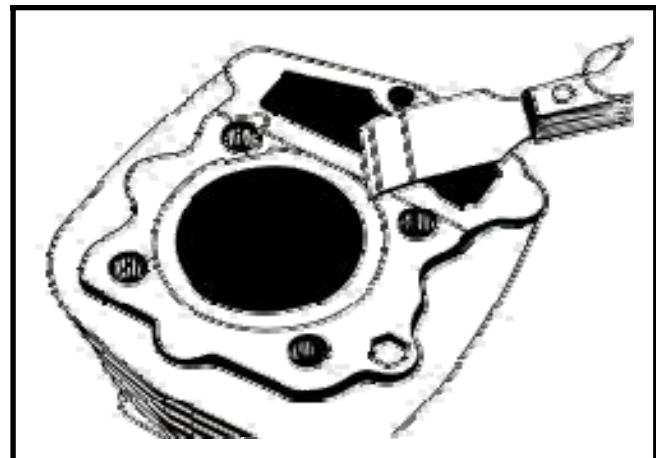

CYLINDER INSPECTION

Inspect the cylinder bore for wear or damage.
 Measure the cylinder I.D.

NOTE:

According to the right picture measure the cylinder runout.

Service limit:

ITEM	
Runout	0.05mm
Taper	0.05mm
I.D.	56.52mm(125c.c.)
	62.05mm(165c.c.)

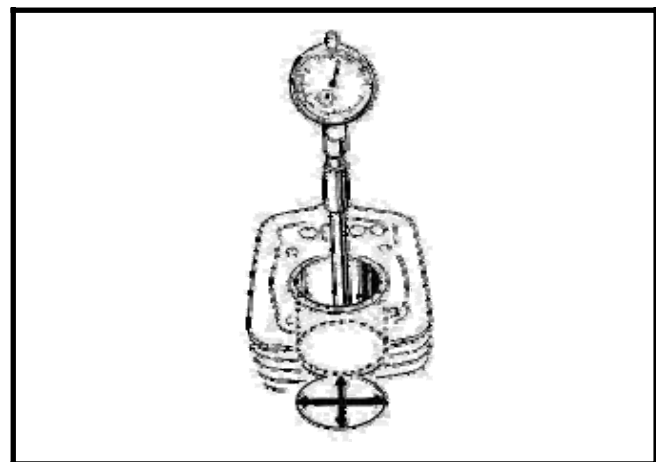

PISTON REMOVAL

Remove the piston pin clip with pliers.
Press the piston pin out of piston, remove the piston.

NOTE:

Avoid the clip falling into the crankcase.



PISTON / PISTON RING

INSPECTION

Measure the piston ring-to-ring groove clearance.
Service limit .

Top ring: 0.060mm
Second ring: 0.045mm

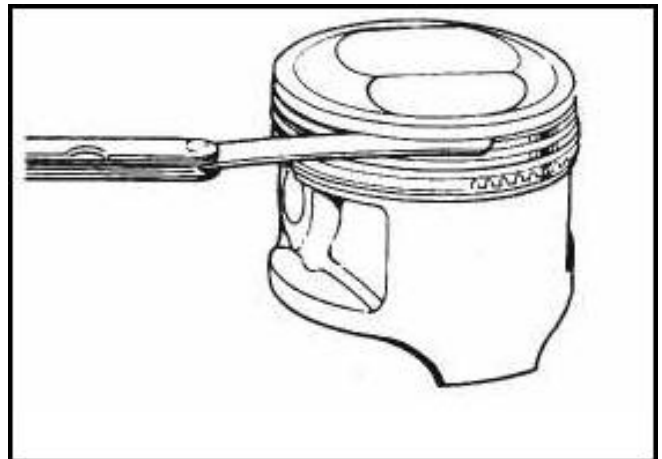

Remove the piston rings.
Inspect the piston for damage or cracks.
Inspect the piston groove for wear.



Insert each piston ring into the cylinder and
measure the ring end gap.

Top ring : 0.5mm
Second ring : 0.7mm

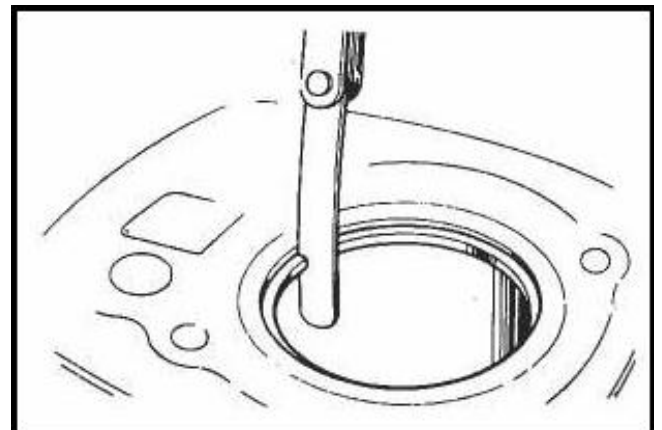

6.CYLINDER/PISTON



Measure the piston O.D. at the skirt.
Service limit:
56.48mm(125c.c.)

NOTE:

Measure the piston O.D. at a point from the bottom.

Calculate the piston-to-cylinder clearance.
Service limit:
0.20mm(125c.c.)

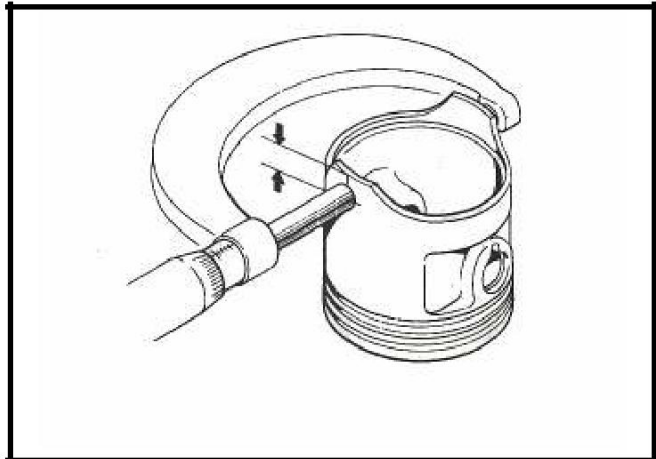

Measure the piston pin bore I.D.
Service limit:15.05mm

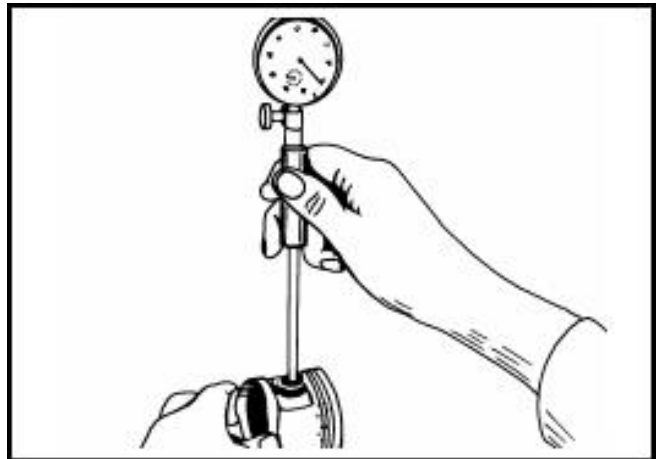

Measure the piston pin O.D.
Service limit:14.994mm

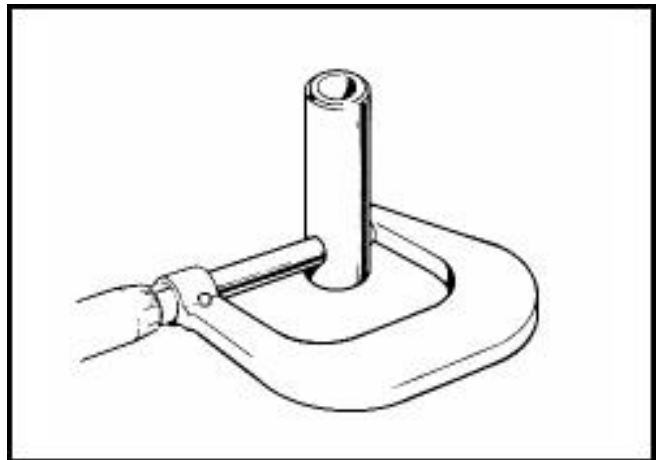

Measure the top/second ring thickness.

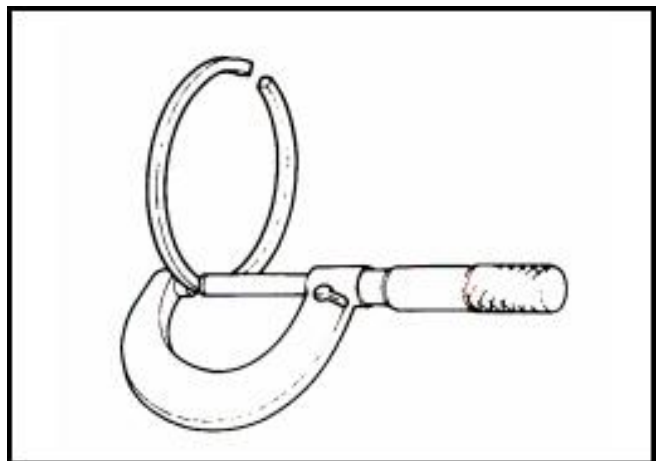

PISTON RING INSTALLATION

Install the piston rings.

NOTE:

Avoid piston and piston ring damage during installation.
 All rings should be installed with the markings facing up.
 After installation, the piston rings should be free to rotate in the grooves.

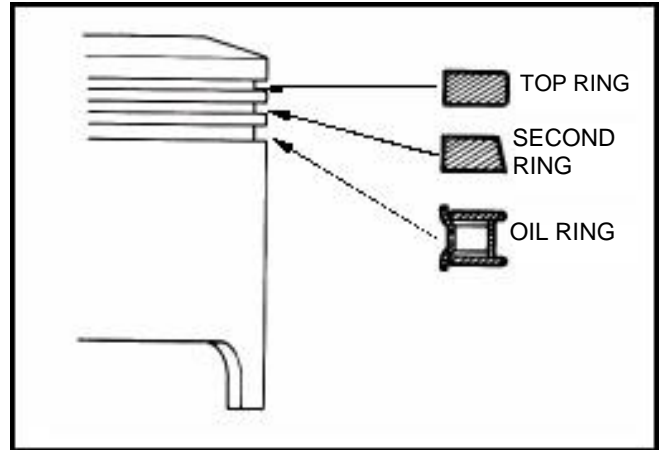

Space the piston ring end gaps 120 degree apart.

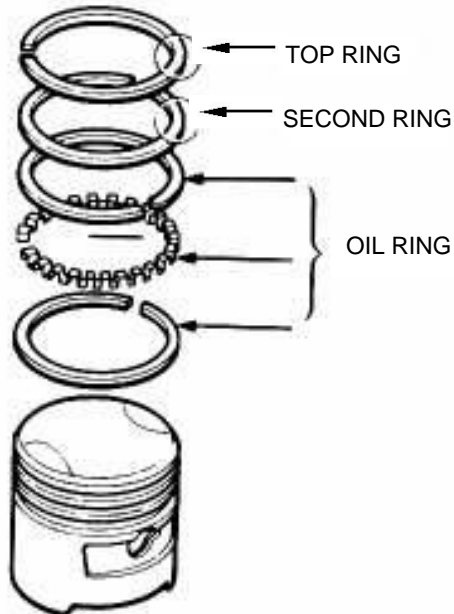
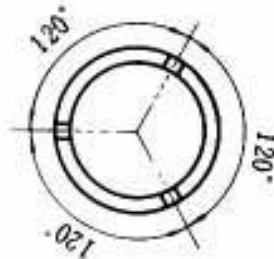

PISTON INSTALLATION

Install the piston, piston pin and piston pin clip.

NOTE:

Position the "IN" mark on the piston to the carburetor side.
Do not let the piston pin clip fall into the crankcase.

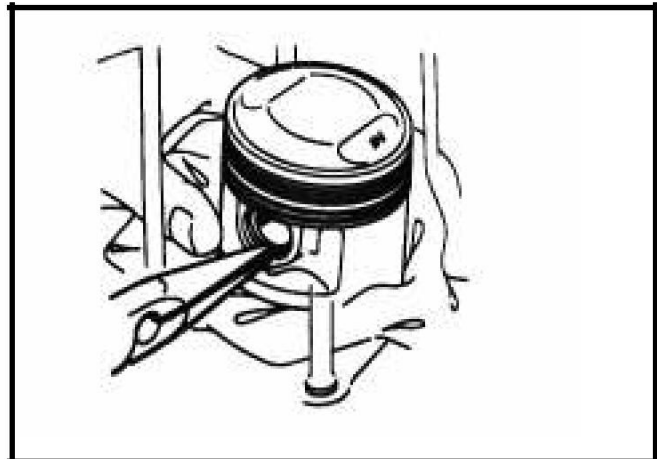

NOTE:

Use new piston pin clip whenever disassembling.
Do not align the piston pin clip end gap with the piston cutout.

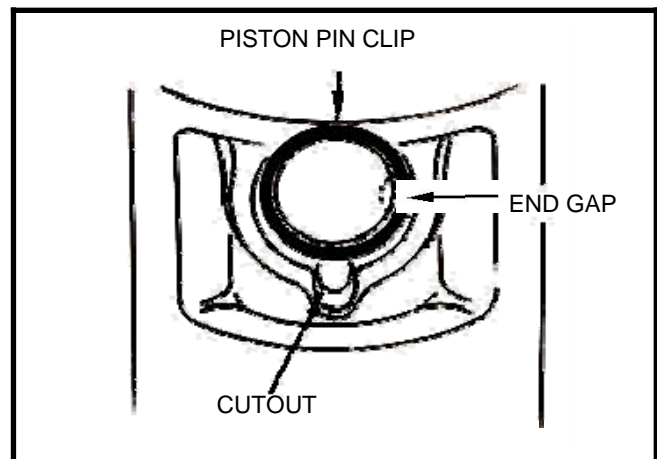

CYLINDER INSTALLATION

Install the cylinder gasket and dowel pins.
Clean the cylinder gasket surface of any gasket material.

NOTE:

Avoid damaging the cylinder gasket surface during this operation.

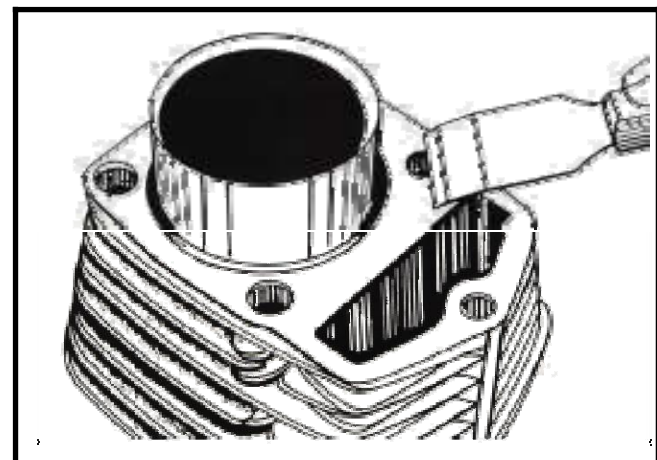

Install the cylinder.

NOTE:

Avoid piston and piston rings damage during installation.

Install the cylinder gasket and dowel pins.
Install the cylinder head.(5-8)

NOTE:

Coat the cylinder and piston with the engine oil before installing the cylinder.



TROUBLE SHOOTING.....	7-1	OIL PUMP	7-7
SERVICE INFORMATION.....	7-1	GEARSHIFT LINKAGE	7-9
RIGHT CRANKCASE COVER REMOVAL .	7-2	RIGHT CRANKCASE COVER INSTALLATION ...	7-11
CLUTCH.....	7-2		

TROUBLE SHOOTING

Faulty clutch operation can be corrected by adjusting the clutch lever free play.

CLUTCH SPINS WHEN ACCELERATING

1. No free play
2. Discs worn
3. Spring weak

CLUTCH DISENGAGED (MOTORCYCLE CREEPS)

1. Too much free play
2. Plates warped

EXCESSIVE LEVER PRESSURE

1. Clutch cable damaged or dirty
2. Lifter mechanism damaged

HARD SHIFTING

1. Stopper plate bent
2. Improper clutch adjustment

GEARSHIFT PEDAL WON'T RETURN

1. Return spring broken or weak
2. Shift spindle bent

JUMPS OUT OF GEAR

1. Stopper arm spring broken

LOW OIL PRESSURE

1. Oil pump drive gear worn
2. Faulty oil pump

SERVICE INFORMATION

GENERAL INSTRUCTION

This section covers removal, installation and servicing of the clutch, oil pump, filter and gearshift linkage. All these operations can be accomplished with the engine in the frame.

COMMON TOOLS

- 22mm wrench socket
- Air wrench

TORQUE VALUES

- Right crankcase cover
- Step bar

0.80 ~ 1.20 kgf.m

1.80 ~ 2.00 kgf.m

SPECIFICATIONS

ITEM		STANDARD SERVICE	LIMIT
Clutch	Leve Free play	10~20mm	-----
	Spring free length	30.6mm	28.6mm
	Friction plate thickness	3.0±0.1mm	2.8mm
	Clutch plate warpage	-----	0.2mm
Oil pump	Tip clearance	0.15mm	0.20mm
	Rotor-to-body clearance	0.10~0.16mm	0.25mm
	End clearance	0.04~0.087mm	0.12mm

RIGHT CRANKCASE COVER REMOVAL

Drain oil from the engine.
Disconnect the clutch cable.
Remove the right crankcase cover.



CLUTCH

CLUTCH REMOVAL

Remove the clutch lifter rod.
Remove the oil filter rotor cover.

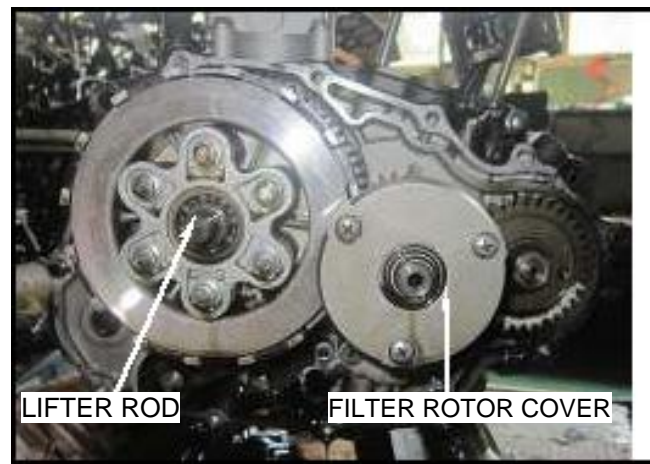

Remove the 16mm lock nut with a lock nut wrench.
Remove the oil filter rotor.



Remove the bearing, clutch bolt, clutch lifter plate and clutch spring.

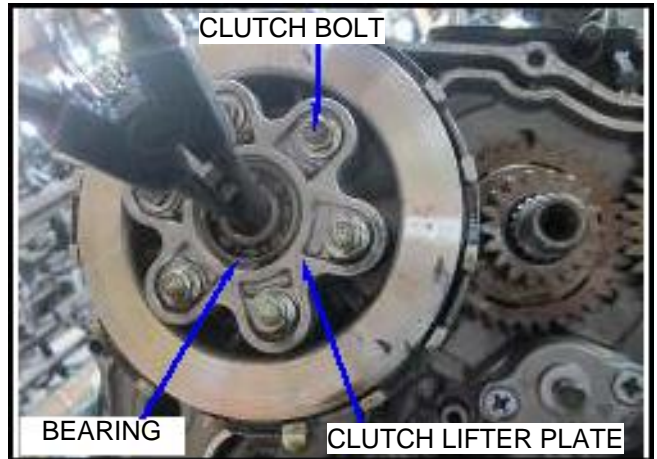

CLUTCH SPRING INSPECTION

Measure the clutch springs free length.
Service limit: 28.6mm

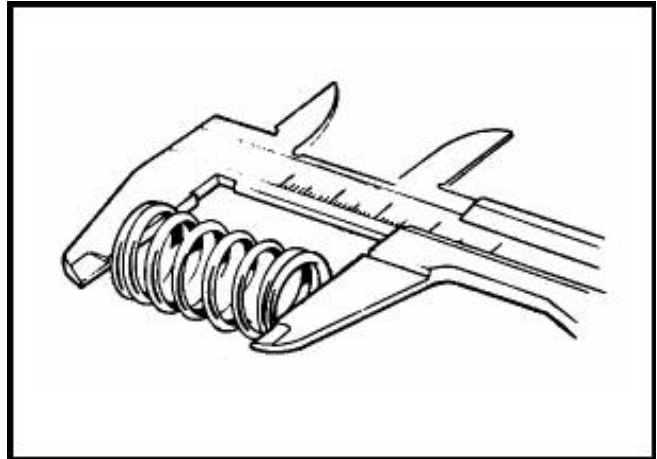

Remove the 20mm set ring.



Remove the clutch center, disks, plates and pressure plate.

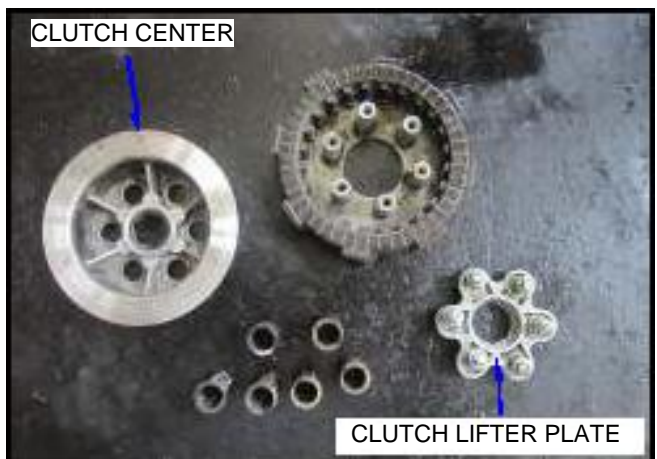

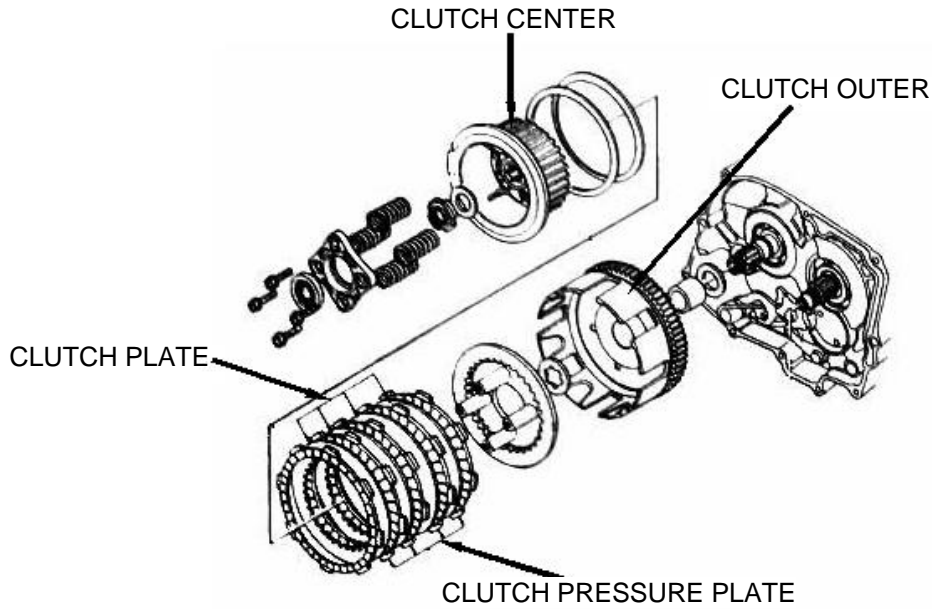

CLUTCH FRICTION DISC INSPECTION

Replace the clutch disks if they have any score or discoloration.

Measure the clutch friction disk thickness.

SERVICE LIMIT: 2.8mm

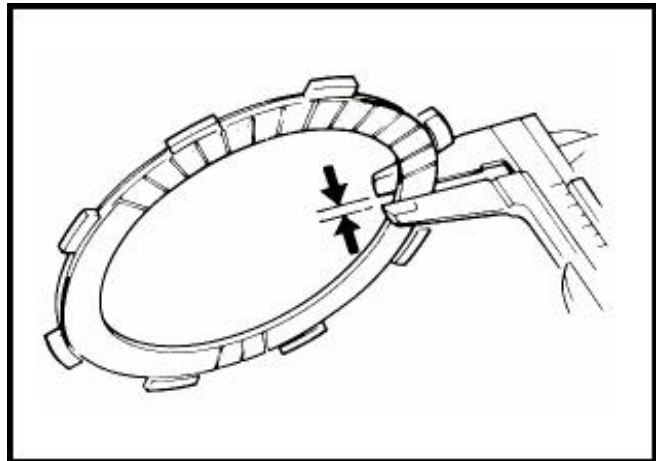

CLUTCH PLATE INSPECTION

Check the plates for warpage on a surface plate using a feeler gauge.

Service limit: 0.2mm

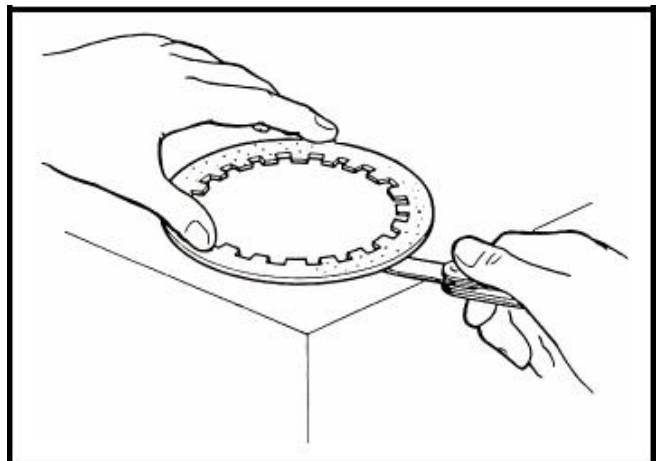

Remove the 20 mm washer and clutch outer.



CLUTCH OUTER INSPECTION

Check the clutch outer for cracks or indentation.



CLUTCH OUTER INSTALLATION

Install the clutch outer, 20mm washer on the main shaft.

NOTE:

When installing the washer, it should fit with the main shaft groove.



Install the clutch pressure plate, friction discs, clutch plates and clutch center.

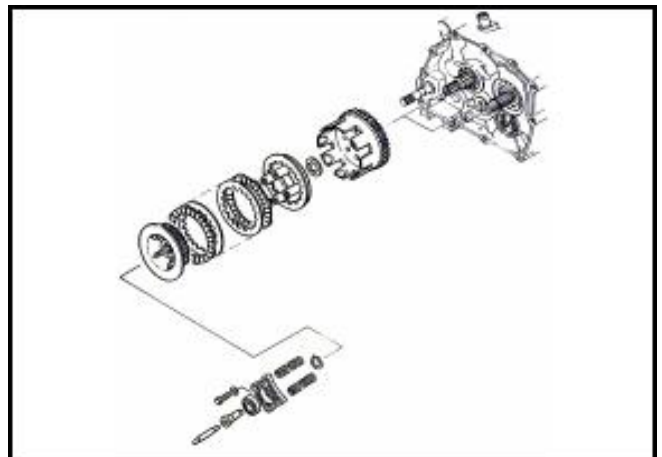

7.CLUTCH/OIL PUMP/GEAR SHIFT



Install and tighten the 20mm set ring.



Install the clutch springs, lifter plate and tighten the bolts.

Install the bearing.

NOTE:

Tighten the bolts in a crisscross pattern in two or three steps.

TORQUE :0.80-1.20 kgf·m

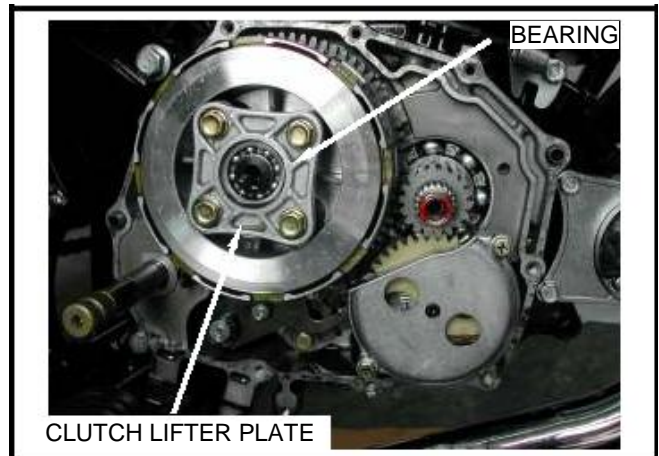

Install the oil filter rotor.

Install the lock washer and 16mm lock nut.

Tighten the 16mm lock nut.

TORQUE :4.00-5.00 kgf·m



Install the filter rotor cover.

Check the oil through for a smooth operation without binding.

Install the lifter rod.

Install the dowel pins and a new gasket.

Install the right crankcase cover

Connect the clutch cable.

Install the exhaust muffler and step bar.

Fill the crankcase with the recommended oil

Adjust the clutch lever free play.

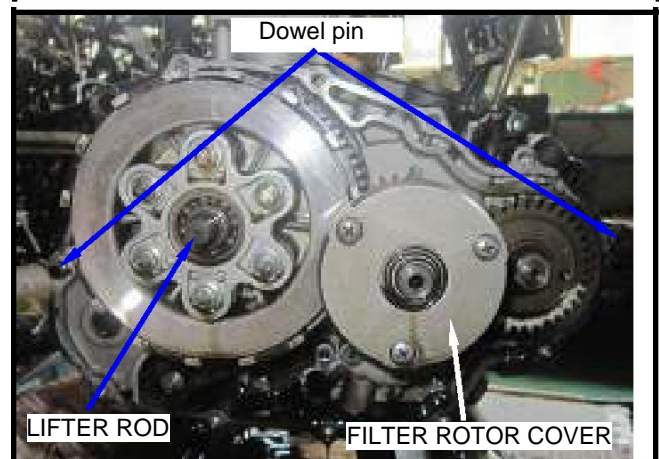

OIL PUMP

OIL PUMP REMOVAL

- Remove the right crankcase cove.
- Remove the oil filter rotor.
- Remove the oil pump cover.
- Remove the oil pump drive gear.
- Remove the 6 mm screws and oil pump.

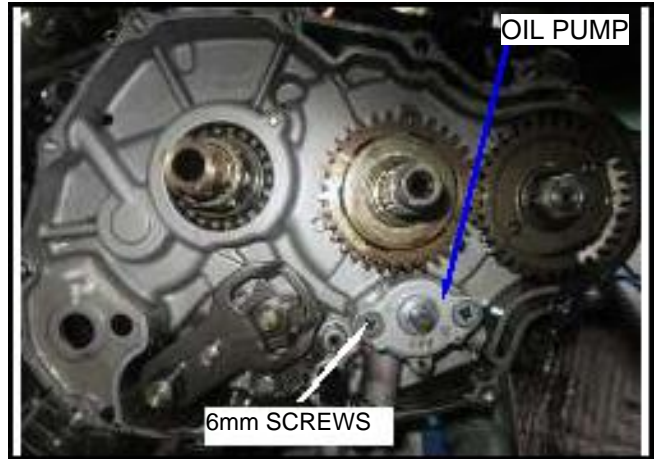

OIL PUMP DISASSEMBLY

- Remove the oil pump plate.



OIL PUMP INSPECTION

- Measure the inner rotor-to-outer rotor clearance.
- SERVICE LIMIT: 0.20mm

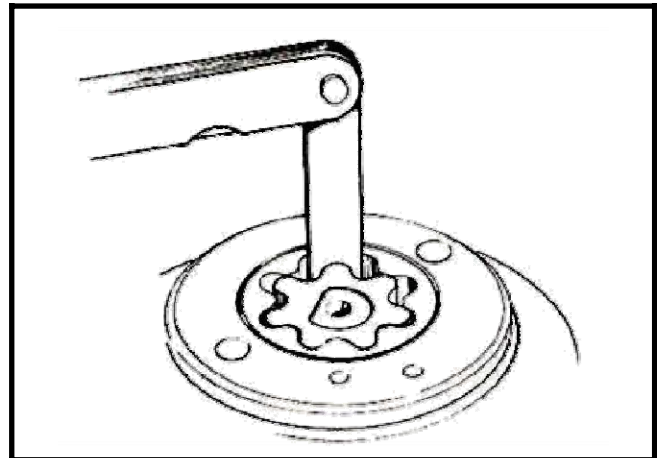

- Measure the outer rotor-to-body clearance.
- Service limit: 0.25mm

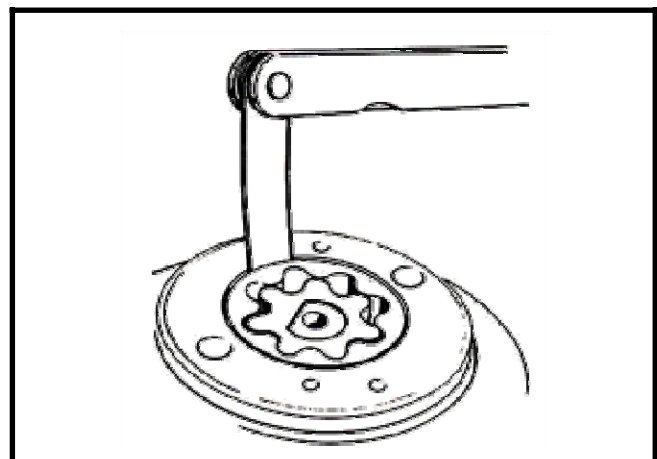

Measure the rotor-to-cover clearance.

NOTE:

Measure the clearance with the gasket installed.

Service limit: 0.12mm

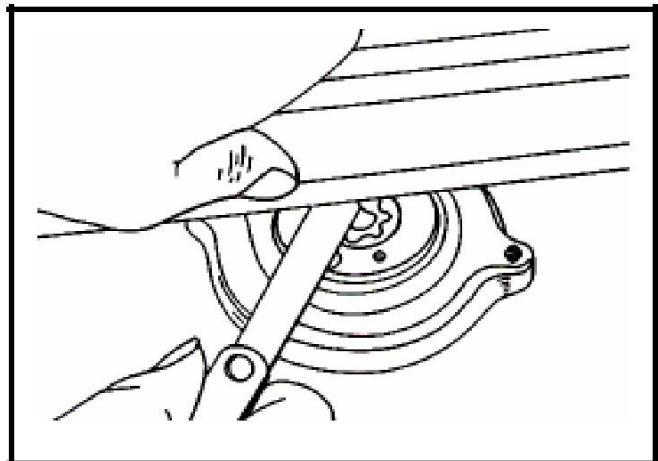

OIL PUMP ASSEMBLY

Install the oil pump drive gear and gear shaft on the pump body.

Install the oil pump cover.

NOTE:

Align the cutout in inner rotor with the cutout on the shaft.

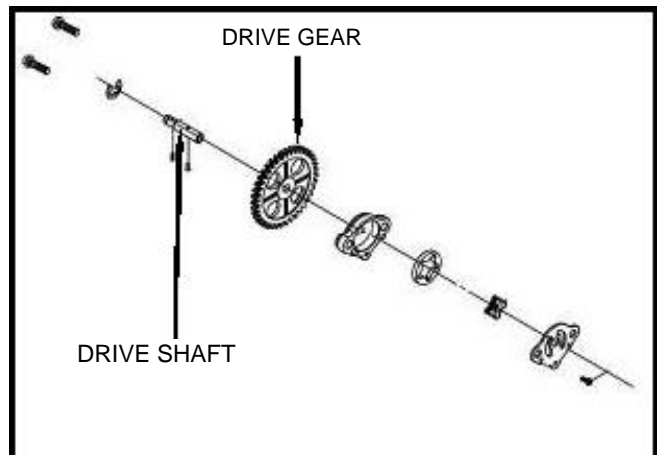

Check the oil pump for rotating freely.



OIL PUMP INSTALLATION

Install the new gasket between right crankcase and oil pump.

Install the oil pump to the right crankcase.



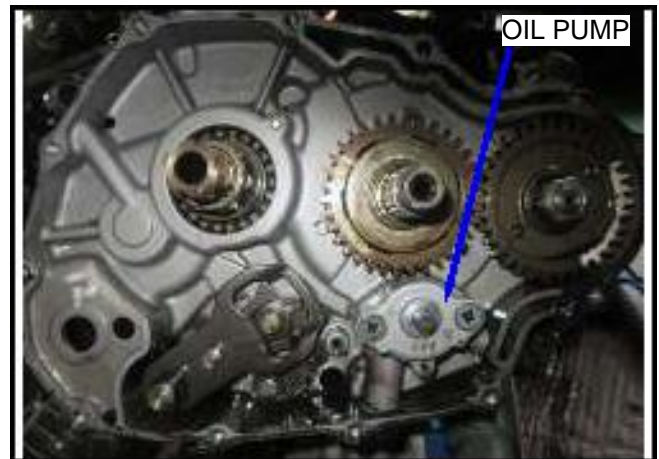

GEARSHIFT LINKAGE GEARSHIFT LINKAGE DISASSEMBLY

Remove the clutch.
Remove the gearshift pedal.
Remove the gearshift spindle.

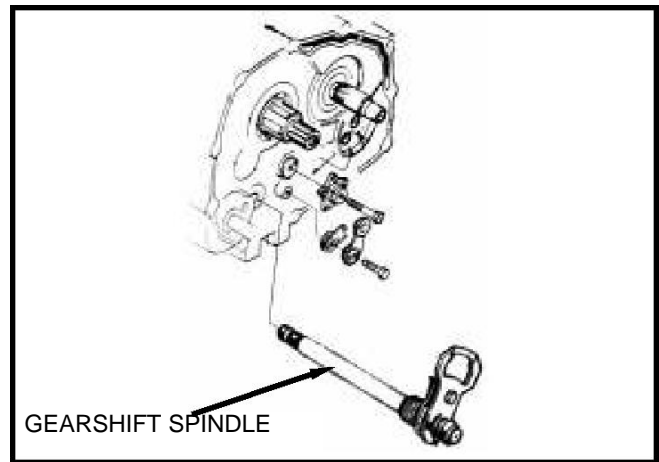

Remove the gearshift drum stopper arm.
Remove the gearshift cam.
Check each part for wear or damage.

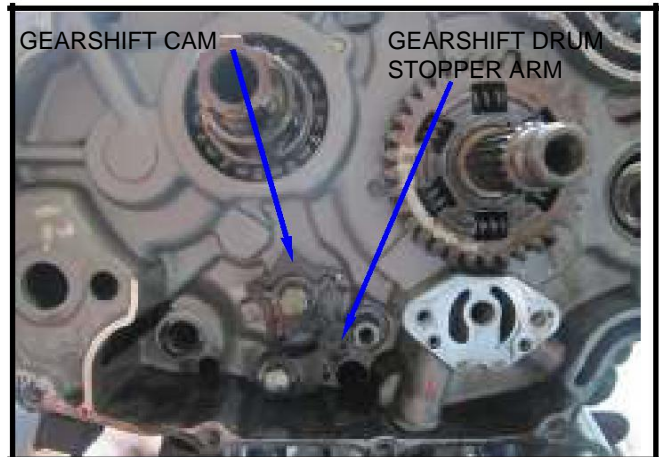

GEARSHIFT LINKAGE ASSEMBLY

Install the four 4mm roller.

Align the hole of the gearshift cam with the roller, then install the gearshift cam.

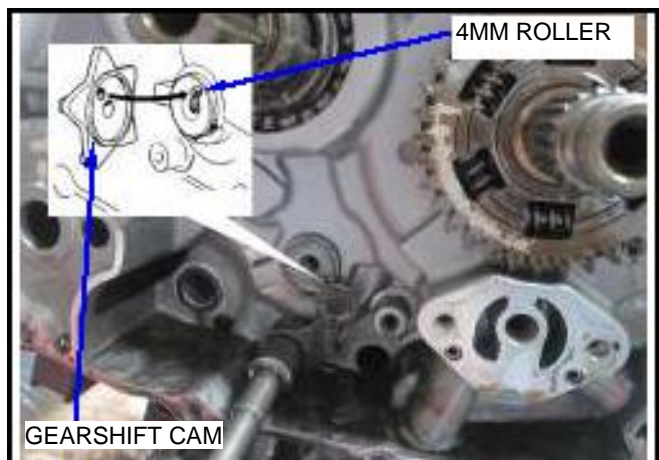

Install the gearshift drum stopper.

NOTE

After installation, check the drum stopper operation.

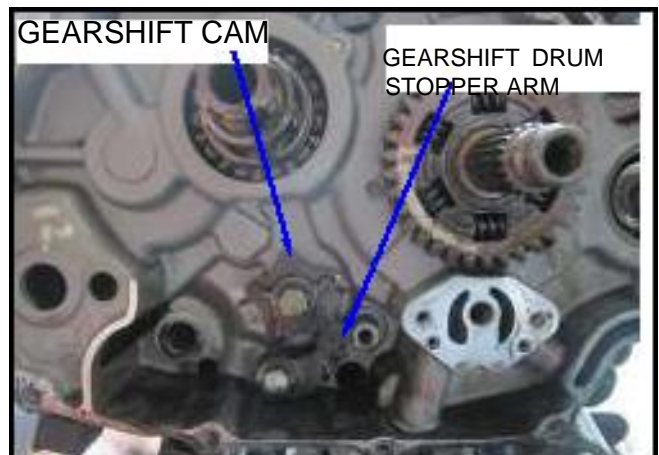

Install the gearshift spindle.

NOTE :

Align the gearshift return spring on the projection of the crankcase.

Check the gearshift linkage for smooth operation.
Install the clutch, balance driven gear, oil pump and oil filter rotor.

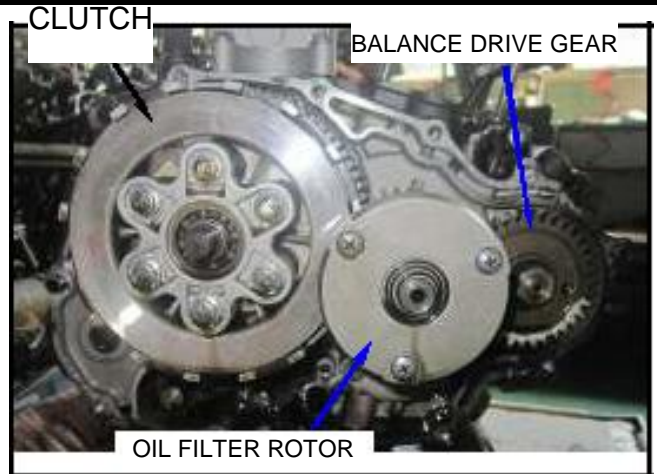
**RIGHT CRANKCASE COVER INSTALLATION**

Install the dowel pins and a new gasket. Install the right crankcase cover and tighten the screws.

Connect the clutch cable.

Fill the crankcase with the recommended oil.

Adjust the clutch lever free play.



SERVICE INFORMATION.....	8-1LEFTCRANKCASECOVERINSTALLATION	8-3
LEFT CRANKCASE COVER REMOVAL.....	8-2	STARTER MOTOR REMOVAL	8-4
FLYWHEEL REMOVAL.....	8-2	STARTER DRIVEN GEAR REMOVAL	8-4
FLYWHEEL INSTALLATION.....	8-3	STARTER MOTOR GEAR SET.....	8-4

SERVICE INFORMATION

GENERAL INSTRUCTION

This section covers removal and installation of the AC generator and starter motor.

These operation can be done with the engine installed in the frame.

Special tool

Rotor puller

TORQUE VALVE

Flywheel bolt 4.00~5.00kgf.m

LEFT CRANKCASE COVER REMOVAL

Remove the gearshift pedal.
Remove the left crankcase rear cover.
Disconnect the AC generator and pulse generator wire connector.
Remove the left crankcase cover.

NOTE:

Generator stator is in the left crankcase cover, it can be removed by removing the attaching screws.

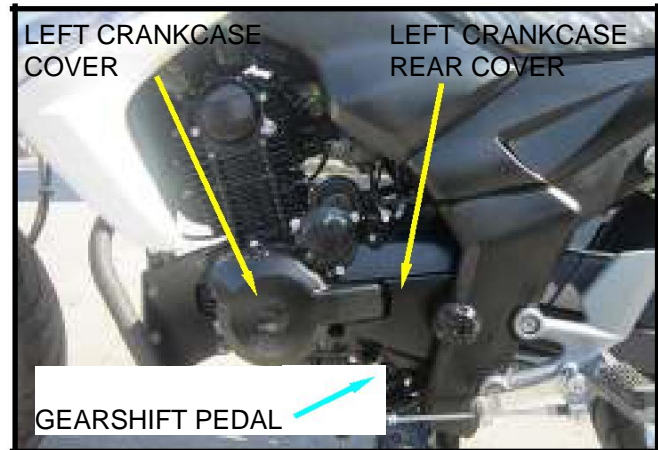

FLYWHEEL REMOVAL

Remove the flywheel bolt.

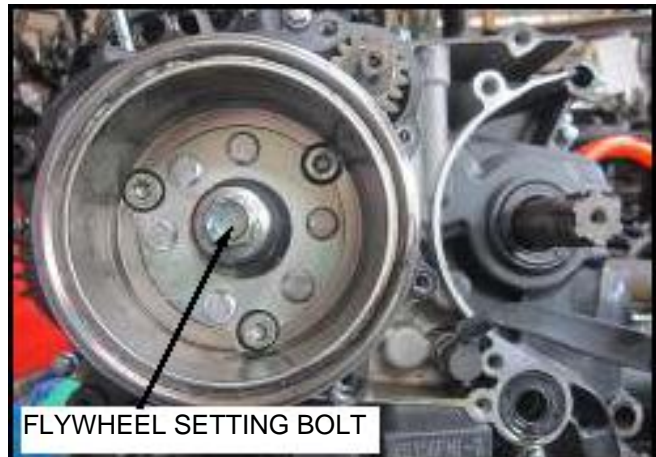

Remove the flywheel with the rotor puller.



STATOR COIL INSPECTION NOTE :

This inspection can be made with the stator in the frame.

Check the starter for continuity.
Continuity should exist between:
Yellow and pink,
Blue/yellow and ground,
Pink,yellow should not continue with the ground.
Replace the stator and pulse generator assembly if necessary.



FLYWHEEL INSTALLATION

Reverse the procedure of removal to assembly.

NOTE :

Check wire for security in its place.
Do not interfere the wire with the flywheel.

Install and tighten the flywheel.

TORQUE: 4.00~5.00 kgf.m

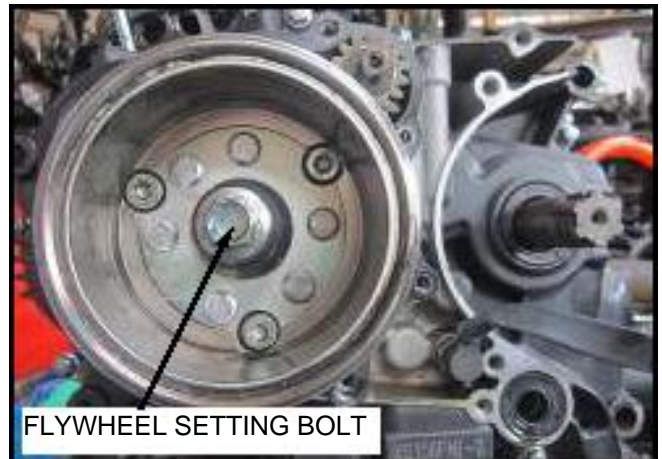

LEFT CRANKCASE COVER INSTALLATION

Install the left crankcase cover (with stator coil)
Connect the generator wire connectors.
Route the neutral switch wire through the groove in the left crankcase cover.
Install the left crankcase rear cover.
Install the gearshift pedal.

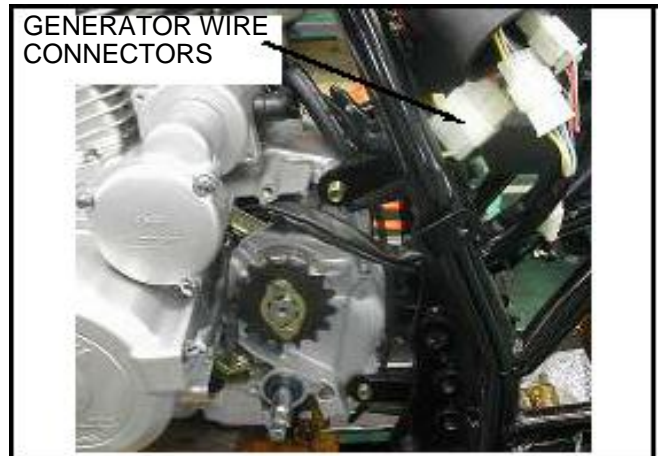

STARTER MOTOR REMOVAL

Disconnect the starter motor wire from the motor.
Remove the starter motor by removing the bolts.

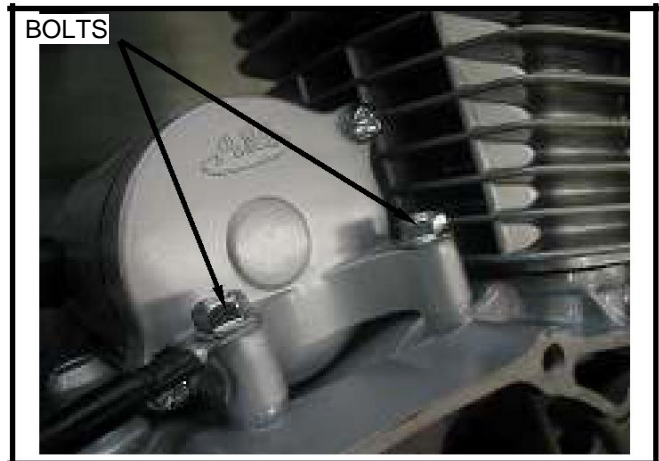

STARTER DRIVEN GEAR REMOVAL

Remove the left crankcase cover .
Remove the flywheel.
Remove the starter driven gear.



STARTER MOTOR GEAR SET

1. Starter driven gear
- 2 Starter reduce gear
- 3 Starter motor

Install the starter motor and gear in the reverse order of removal.

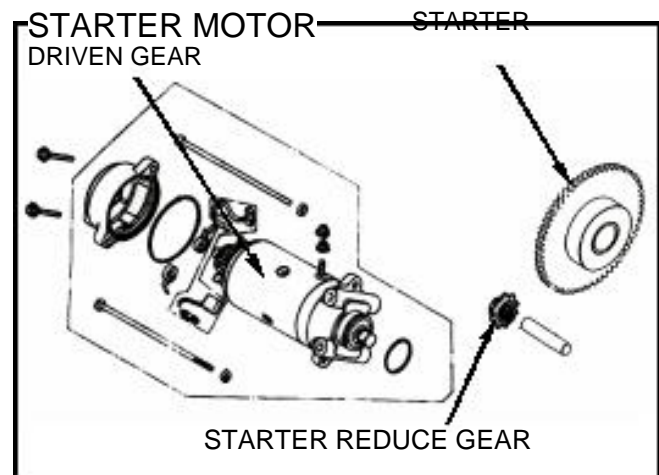

TROUBLE SHOOTING.....9-1	TRANSMISSION DISASSEMBLY.....9-5
SERVICE INFORMATION.....9-2	TRANSMISSION ASSEMBLY.....9-8
CRANKCASE SEPARATION9-2	CRANKCASE ASSEMBLY.....9-11
CRANKSHAFT REMOVAL.....9-3	

TROUBLE SHOOTING

HARD TO SHIFT

1. Shift fork bent
2. Shift fork shaft bent

TRANSMISSION JUMPS OUT OF GEAR

1. Gear dogs worn
2. Shift fork bent or damaged
3. Shift fork shaft bent

CRANKSHAFT NOISE

1. Worn connecting rod big end bearing
2. Bent connecting rod
3. Worn crankshaft bearing

GEAR NOISE

1. Worn transmission gears
2. Worn spline shafts

SERVICE INFORMATION

GENERAL INSTRUCTION

Transmission and crankshaft repairs require crankcase separation.

Remove the following parts before separating the crankcase:

Engine removal	4-2
Cylinder head removal	5-4
Cylinder / Piston removal	6-2
Clutch / oil pump / Gearshift linkage removal	7-2
Left crankcase cover removal	8-2
Flywheel removal	8-2

SPECIAL TOOLS

Bearing driver

Bearing driver pilot

SPECIFICATIONS

ITEM		STANDARD SERVICE	LIMIT	
Gearshift fork	I.D.	12.000 ~ 12.018mm	12.05mm	
	Claw thickness	4.93 ~ 5.00mm	4.80mm	
Shift fork shaft	O.D.	11.976 ~ 11.994mm	11.9mm	
Crankshaft	Runout	0.030mm below	0.050mm	
	Connecting rod small End I.D.	15.000 ~ 15.018mm	15.064mm	
	Connecting rod big End side clearance	Axial	0.050 ~ 0.30mm	0.60mm
		radial	0.000 ~ 0.008mm	0.030mm

CRANKCASE SEPARATION

Remove the right crankcover and internal parts.
(7-3~ 7-13)



Remove left cover and internal parts.



Remove the left crankcover all 6mm attaching bolts.
 Separate the left crankcase from the right crankcase.
 Remove the gasket and dowel pins.



CRANKSHAFT REMOVAL

Remove the left crankcase.
 Remove the crankshaft.

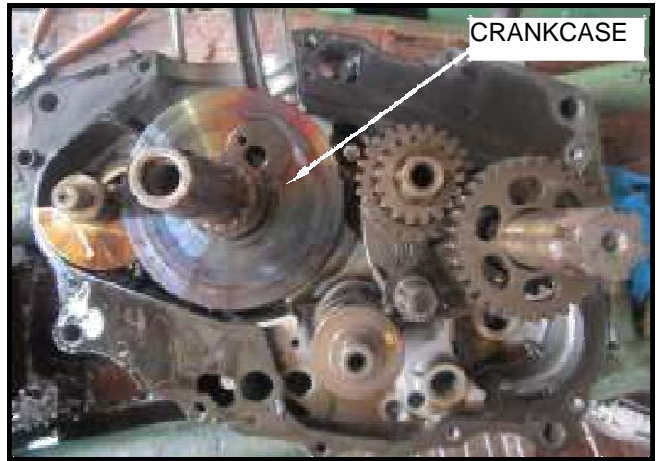

CRANKSHAFT INSPECTION

Measure the connecting rod big end side clearance with a feeler gauge.
 Service limit: 0.60mm

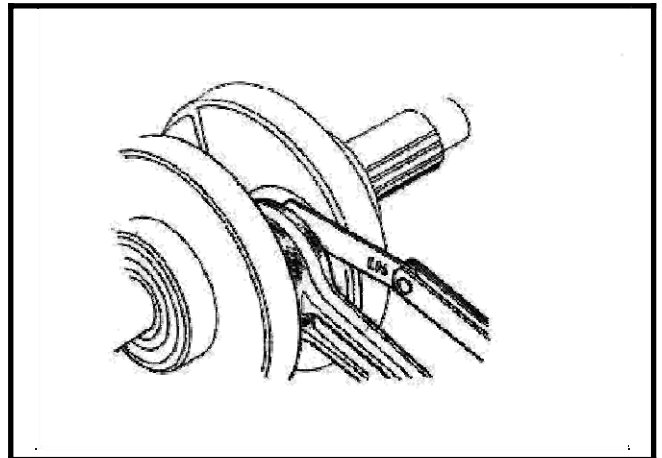

Measure the connecting rod big end radial clearance.
 Service limit: 0.05mm

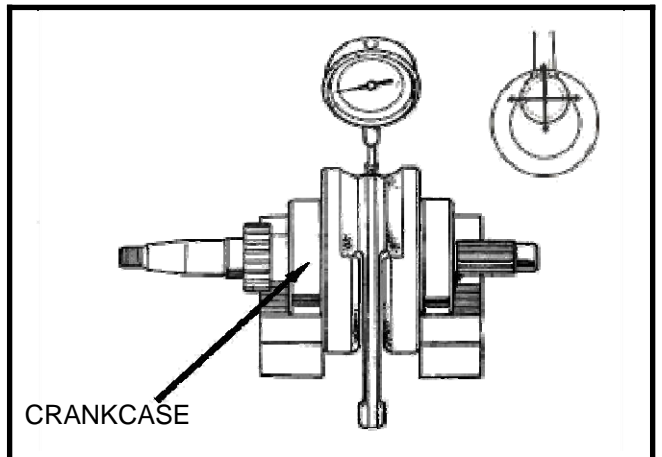

Support the crankshaft bearings on a V-block and measure the runout using a gauge.

NOTE:

Coat the bearing and connecting rod big end with engine oil before installation.

Service limit: 0.050mm

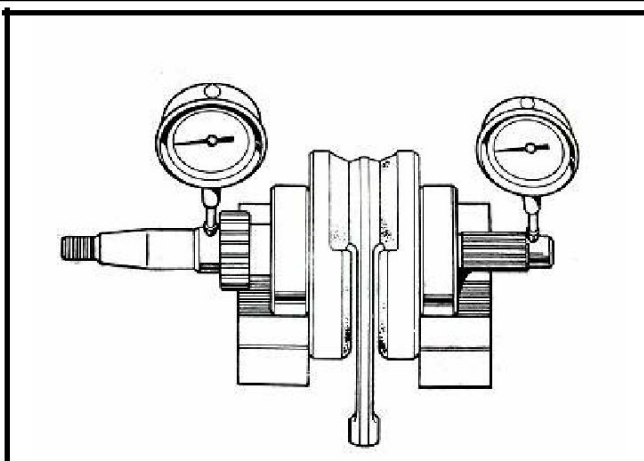

Measure the connecting rod small end I.D.
 Connecting rod small end I.D.
 Service limit: ϕ 15.064mm

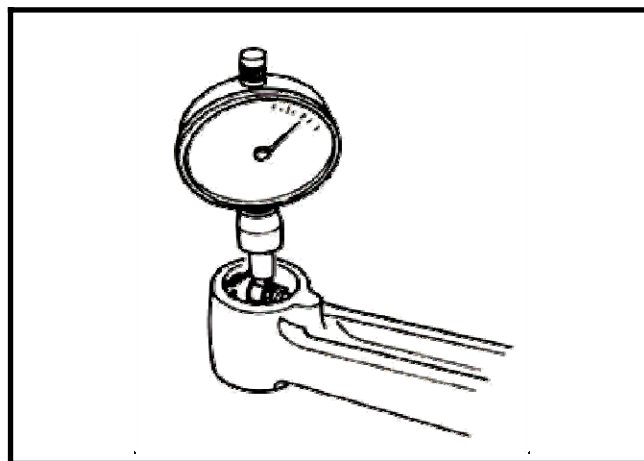

CRANKSHAFT BEARING INSPECTION

Spin the crankshaft bearing by hand and check for play. The bearing must be replaced if it is noisy or has excessive play.

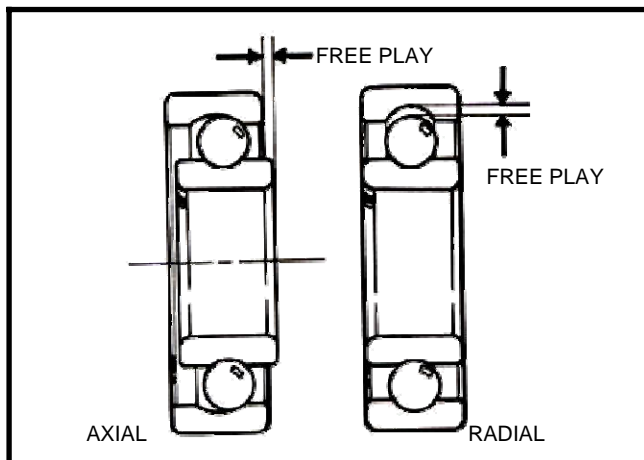

TRANSMISSION DISASSEMBLY

- Remove the crankshaft.
- Remove the shift fork shaft.
- Remove the shift drum.
- Remove the shift forks.

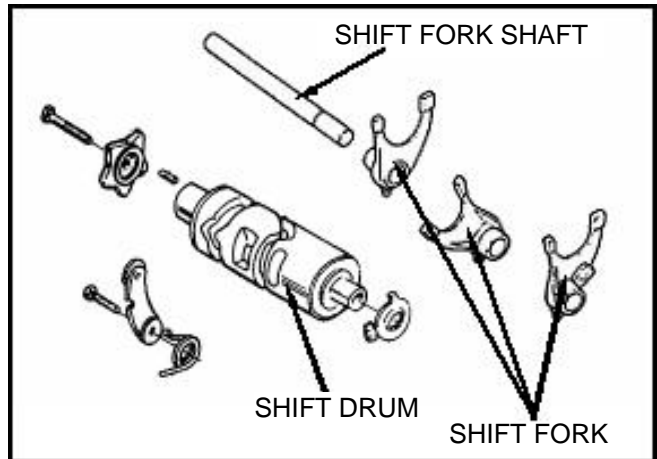
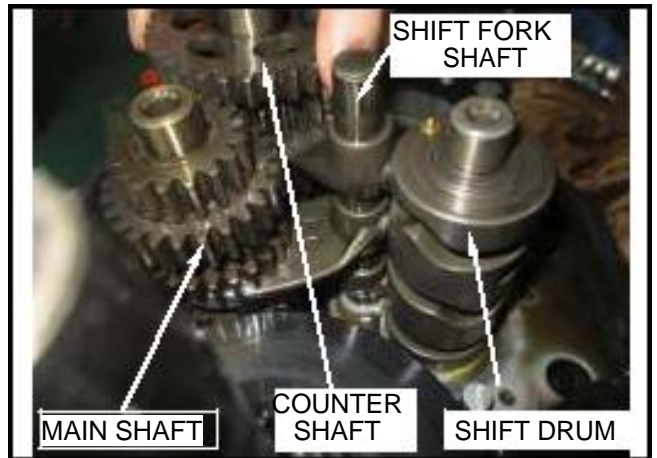

SHIFT FORK AND SHIFT FORK SHAFT INSPECTION

- Check the shift fork for wear, bending or damage.
- Measure the shift fork I.D.
- Service limit: 12.05mm

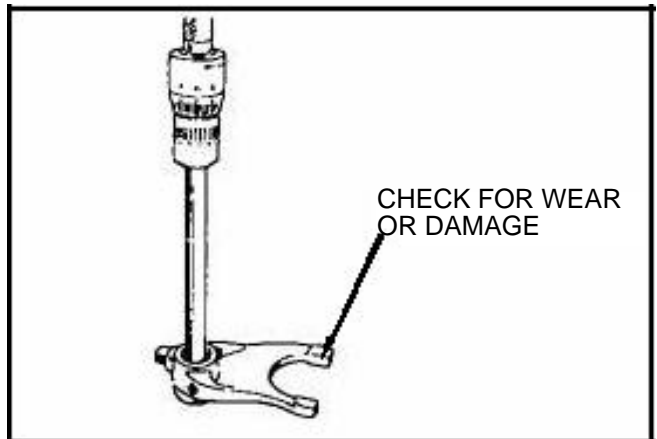

- Measure each shift fork claw thickness.
- Service limit: 4.80mm

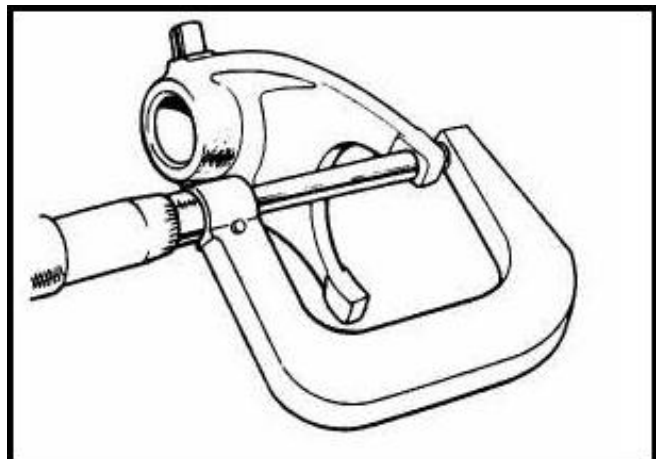

Measure the shift fork shaft O.D.
Service limit: 11.90mm

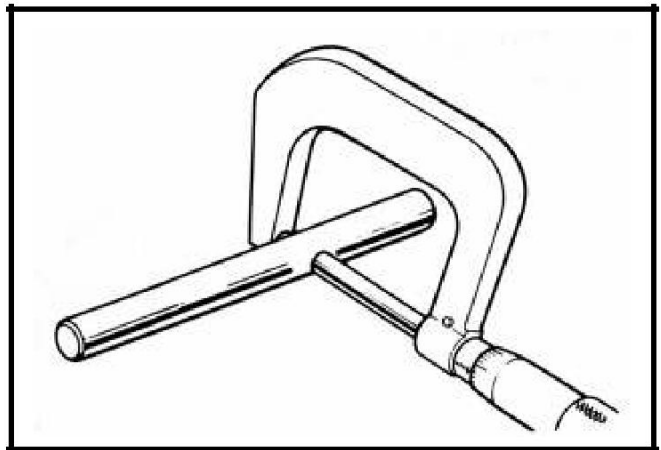

SHIFT DRUM INSPECTION

Check the gearshift drum for wear or damage.



Disassemble the transmission gears.
Check each gear for wear or damage and replace if necessary.

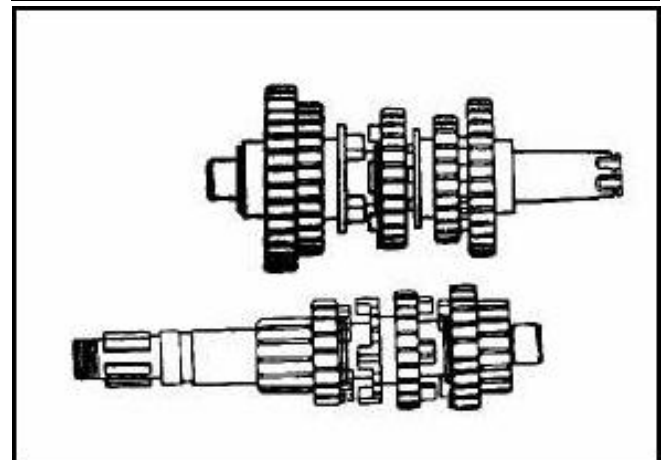

Check the crankcase oil orifice for clogged,
blowing through with compressing air if necessary.



Check the crankcase bearings, replace them if they have excessive free play or noisy.

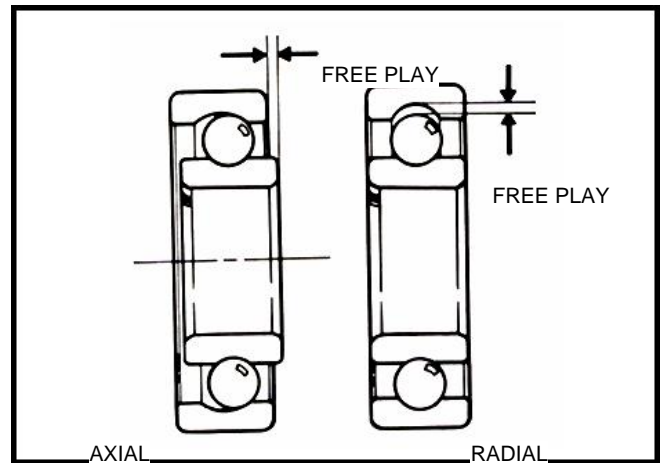

BEARING INSTALLATION

Install the bearings into the left, right crankcase with special tools.

NOTE:

Install the bearing horizontally, to prevent bearing damage.

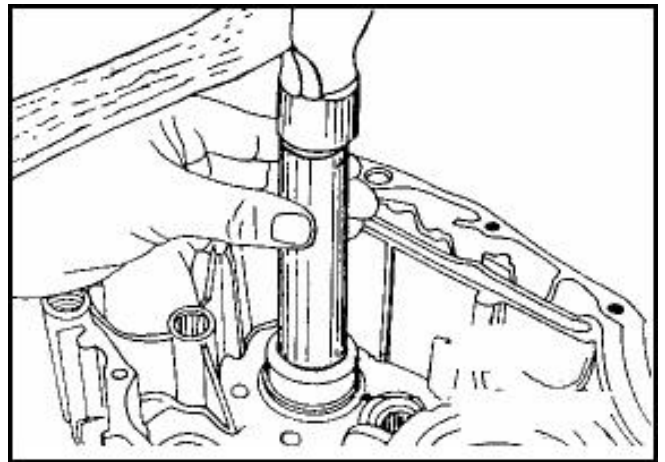

TRANSMISSION ASSEMBLY

NOTE:

Before assembling, coat each gears with engine oil.

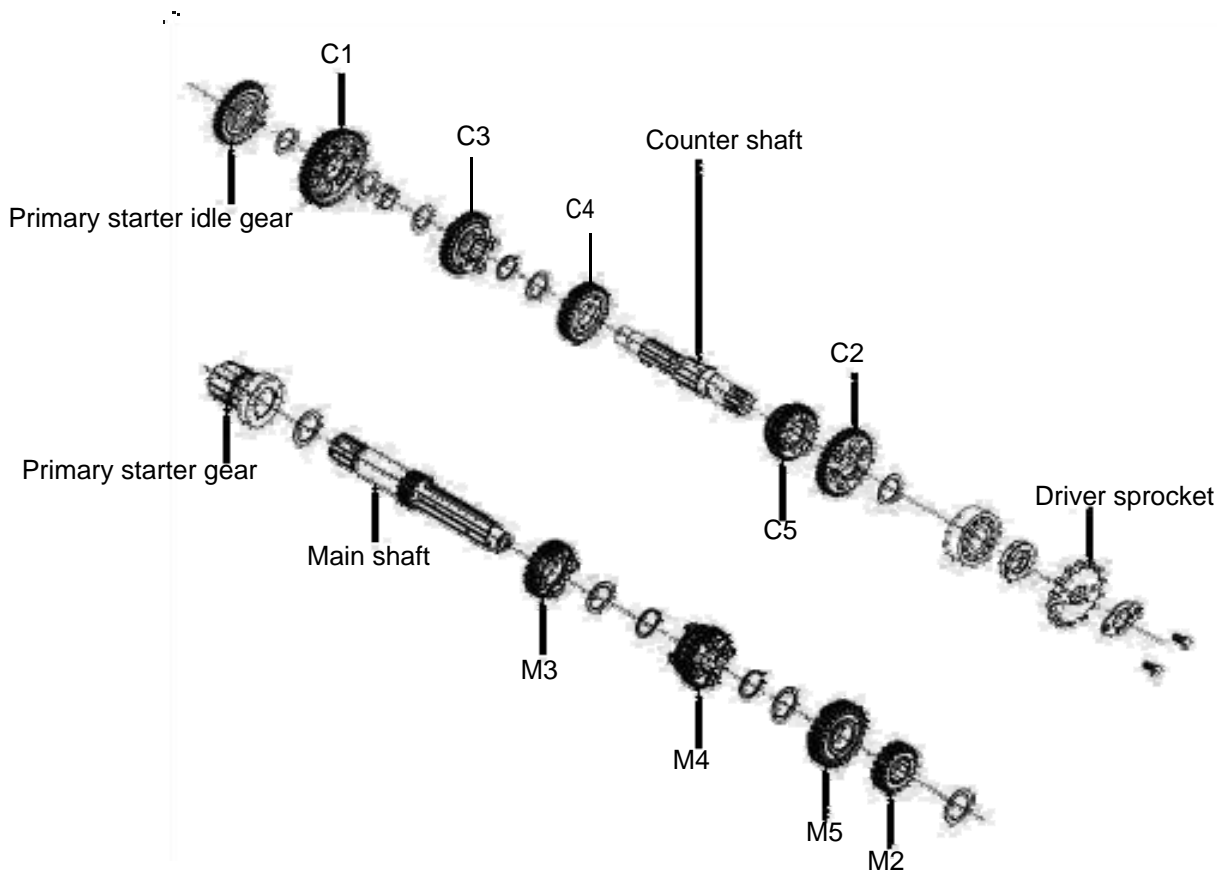

Assemble the gears of the countershaft and mainshaft.

NOTE:

Seat the snap ring in the ring groove properly.

Install the crankshaft assemblies in the right crankcase.

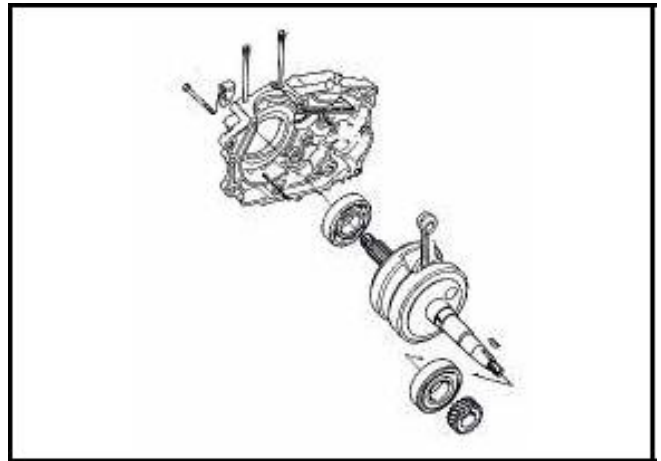

Install the mainshaft and countershaft assemblies in the right crankcase.

NOTE:

Keep the thrust washers in place during installation.

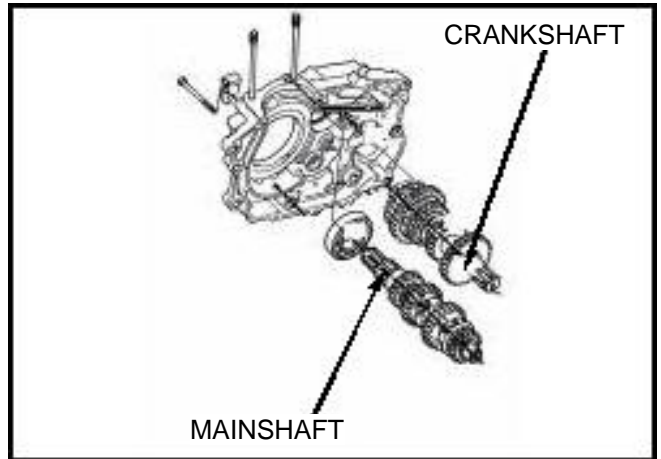

Install the mainshaft, countershaft and shift forks.

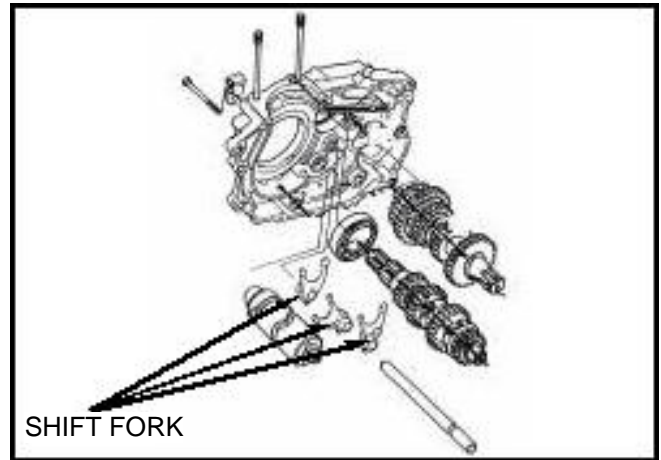

Install the gearshift drum.
Install the shift fork shaft.

NOTE:

Engage the shift fork guide pin with the drum groove by raising the shift fork.
After assembling, check each part for moving freely.



Crankcase assembly

Remove the crankcase gasket and dowel pins.

Clean the gasket residues off the crankcase contact surface.

Caution

Do not damage the contact surface of the crankcase.
Use solvent to wet the gasket material in order to remove it more easily.

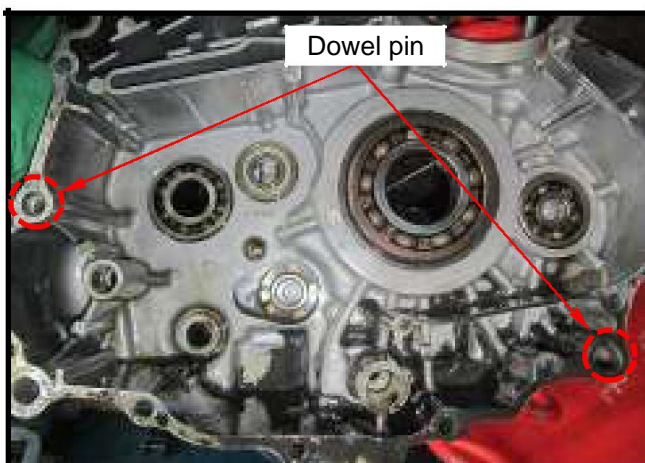

Install main shaft and counter shaft to the right crankcase.

Caution

Make sure the right washer in the position.



Install the gear shift drum.

Caution

When installing shift forks, make sure the letters facing upward.

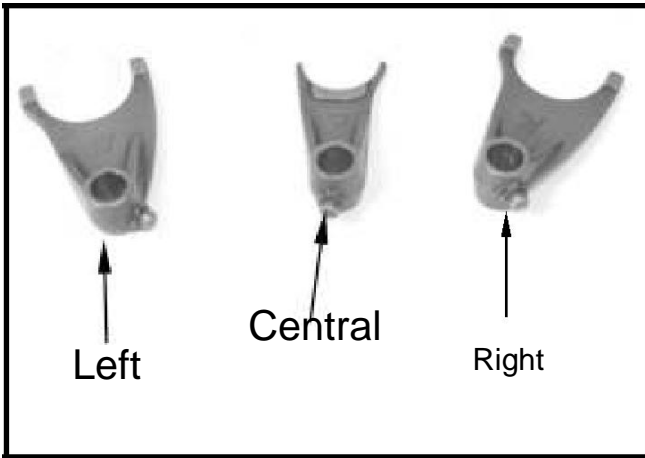

Install shift forks (left, right) on counter shaft, and install the shift fork pin into shifting drum groove. Install shift fork (center) on main shaft, and install Guide shaft the shift fork pin into shifting drum groove. Align the holes of shift forks, then insert gear fork guide shaft.

Caution

Make sure all parts move smoothly; rotate the gear shift drum to neutral gear. (rotate the main shaft, and the counter shaft will not rotate simultaneously).

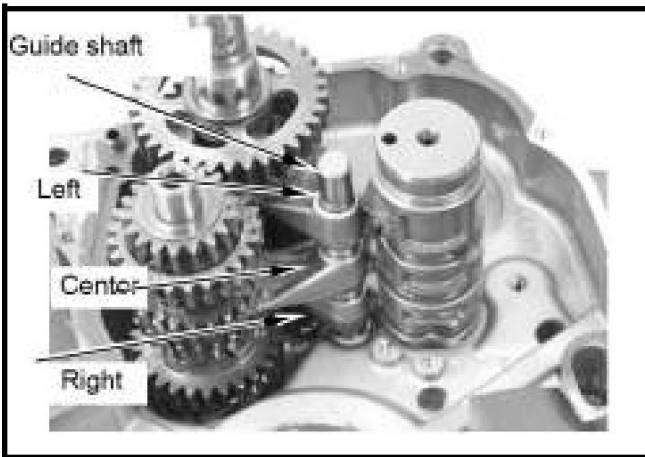

Install crankshaft and balancing shaft to the right crankcase.

Install the new crankcase gasket and dowel pins.

Install left crankcase.

Tighten crankcase left side screws.

Torque value: 0.8~1.2kgf-m

Coat grease to the new counter shaft oil seal and install it to crankcase. Tighten crankcase right side bolts.

Torque value: 0.8~1.2kgf-m

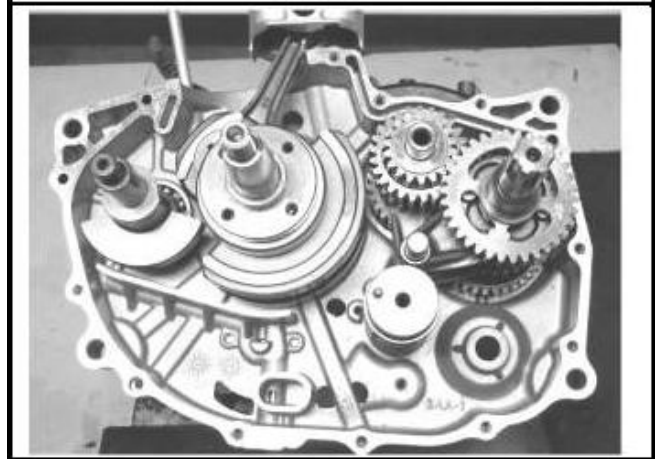

Install balancing shaft drive gear, and align woodruff key and the mark on the gear.

Tighten balancing shaft drive gear bolts.

Torque value: 0.8~1.2kgf-m

Caution

Make sure aligning woodruff key and the mark on the gear; incorrect installation will result in knocking of crankshaft and balancing shaft and cause serious damage.

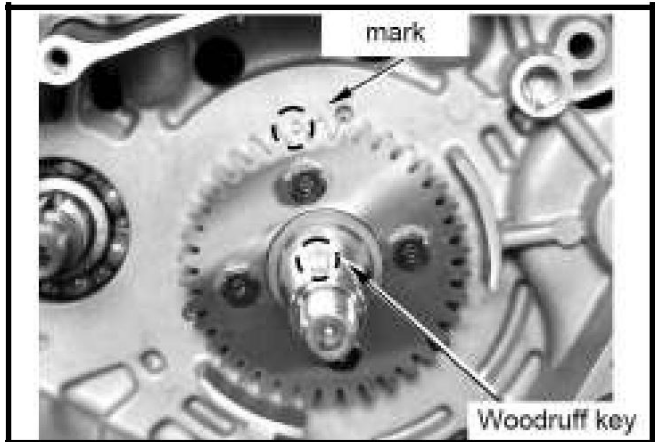

Install balancing shaft gear, align marks on balancing shaft gear and balancing shaft drive gear.

Caution

Make sure aligning marks on balancing shaft gear and balancing shaft drive gear; Woodruff key incorrect installation will result in knocking of crankshaft and balancing shaft and Lock nut cause serious damage.

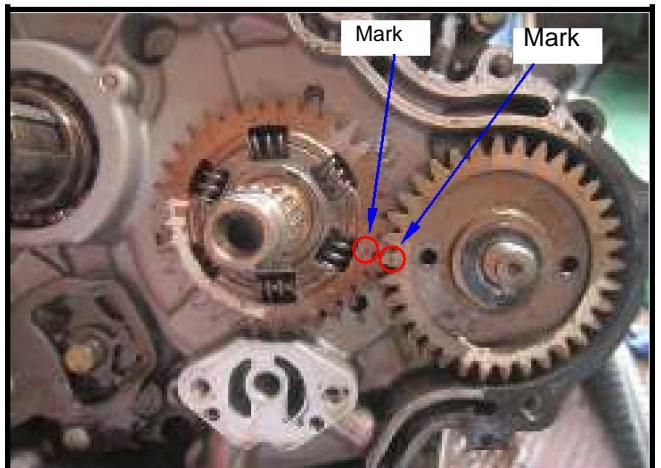

Install the lock washer 12mm on the balancing shaft gear.
Tighten balancing shaft lock nut 12mm.
Torque value: 4.0~5.0kgf-m



EFi System Diagram	4-1	Crankshaft Position Sensor	4-17
EFi System Introduction	4-2	Engine Temperature Sensor / T-Map Sensor	4-18
EFi System Components	4-3	Air By-pass Valve	4-19
EFi System Location	4-4	Fuel Injector	4-19
EFi System Component Description ..	4-5	Fuel Pump	4-19
EFi System Circuit	4-8	Fuel Unit	4-20
Precautions in Operation	4-9	Fuel Tank	4-23
Troubleshooting	4-10	Air Cleaner	4-24
Throttle Body & By-pass Valve Clean Procedure	4-14	EFi Troubleshooting & Solution	4-25
Fuel Lines	4-15	EFi Components Malfunction Check & Replacement Procedure	4-53
Ignition System	4-16		

EFi System Diagram

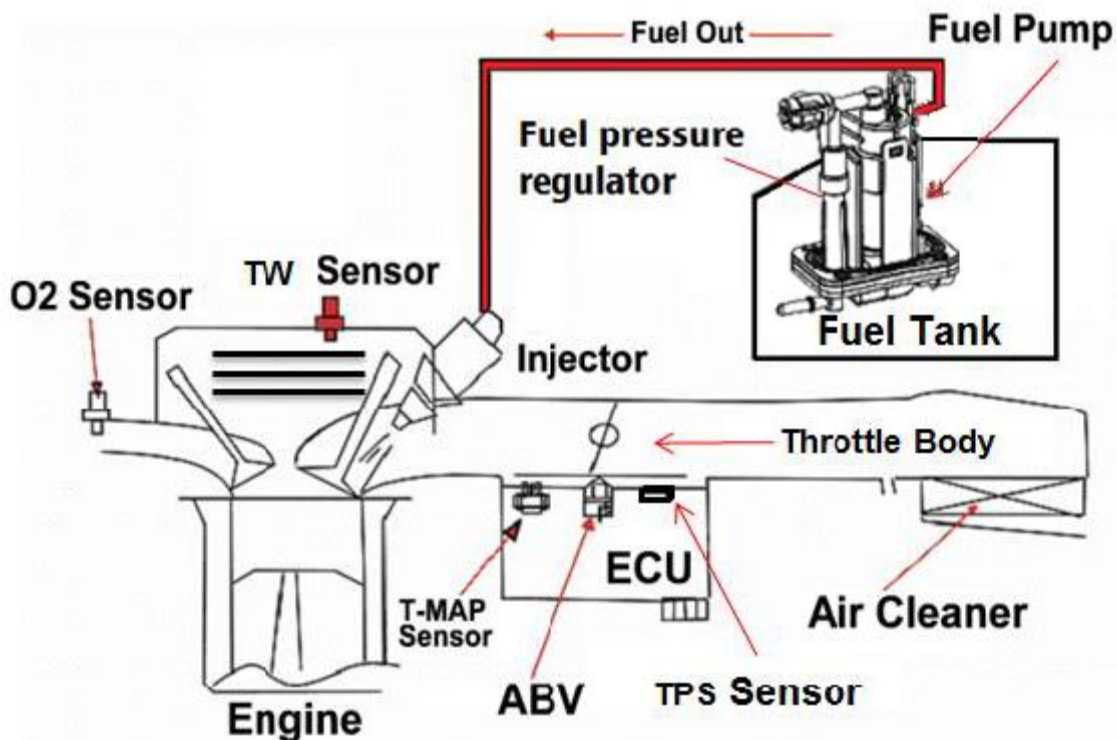

EFI System Introduction

Based on 4-stroke SOHC engine, displacement 125/180 c.c. electronically controlled fuel injection. The O₂ sensor enhances the efficiency of the catalytic converter, by dynamically controlling the Fuel/Air ratio.

Electronic Fuel Injection Device

Fuel supply devices: fuel tank, fuel pump, fuel filter, and fuel pressure regulator.

Fuel control devices: fuel injector, and ECU.

The fuel is pumped from electrical fuel pump in the fuel tank, to the injector on the inlet pipe.

The fuel pressure regulator keeps the pressure around 2.5 Bar. The signals from ECU enable the injector to spray fuel into the combustion chamber once each two crankshaft-revolutions. The excessive fuel flows back to the fuel tank through the fuel pressure regulator. Fuel pump is placed inside the fuel tank to reduce the working noise, and the complicity of fuel pipes.

Electrically controlled ignition and injection system effectively reduce fuel consumption rate and pollution.

In traditional gasoline engine, carburetor supplies the fuel. The process is done by the engine vacuum, and the negative pressure in the carburetor mixes fuel with air. Under this condition, three major processes are done simultaneously in the carburetor: 1. air quantity measurement, the determination of fuel quantity, the mix of fuel and air.

Electronic fuel injection system separates the three major processes into three different devices:

1. T-MAP sensor measures the air quantity and temperature and sends the signal to ECU as a reference.
2. ECU determines the amount of fuel to be injected, according to the default A/F rate.
3. ECU enables the injector to spray appropriate fuel amount. The independence of these three functions will raise the accuracy of the whole process.

EFI engine uses computer-programmed fuel injection, the main features are:

1. The quantity of fuel injected is determined according to the condition of the engine. The engine RPM, and throttle position determines the fuel quantity and injection time-length.
2. The quantity of fuel injection, and the determination of injection time length, are all controlled by 16-bit microcomputer.
3. The fuel pressure regulator maintains a 2.5 Bar pressure difference between inlet pipe and fuel pipe, raising the accuracy of fuel injection.
4. By measuring the air pressure of inlet pipe, this system gives the vehicle better accommodation to the environment.
5. Air by-pass system supplies fuel and air to stabilize the idle running, and cold starting.

EFi System Components

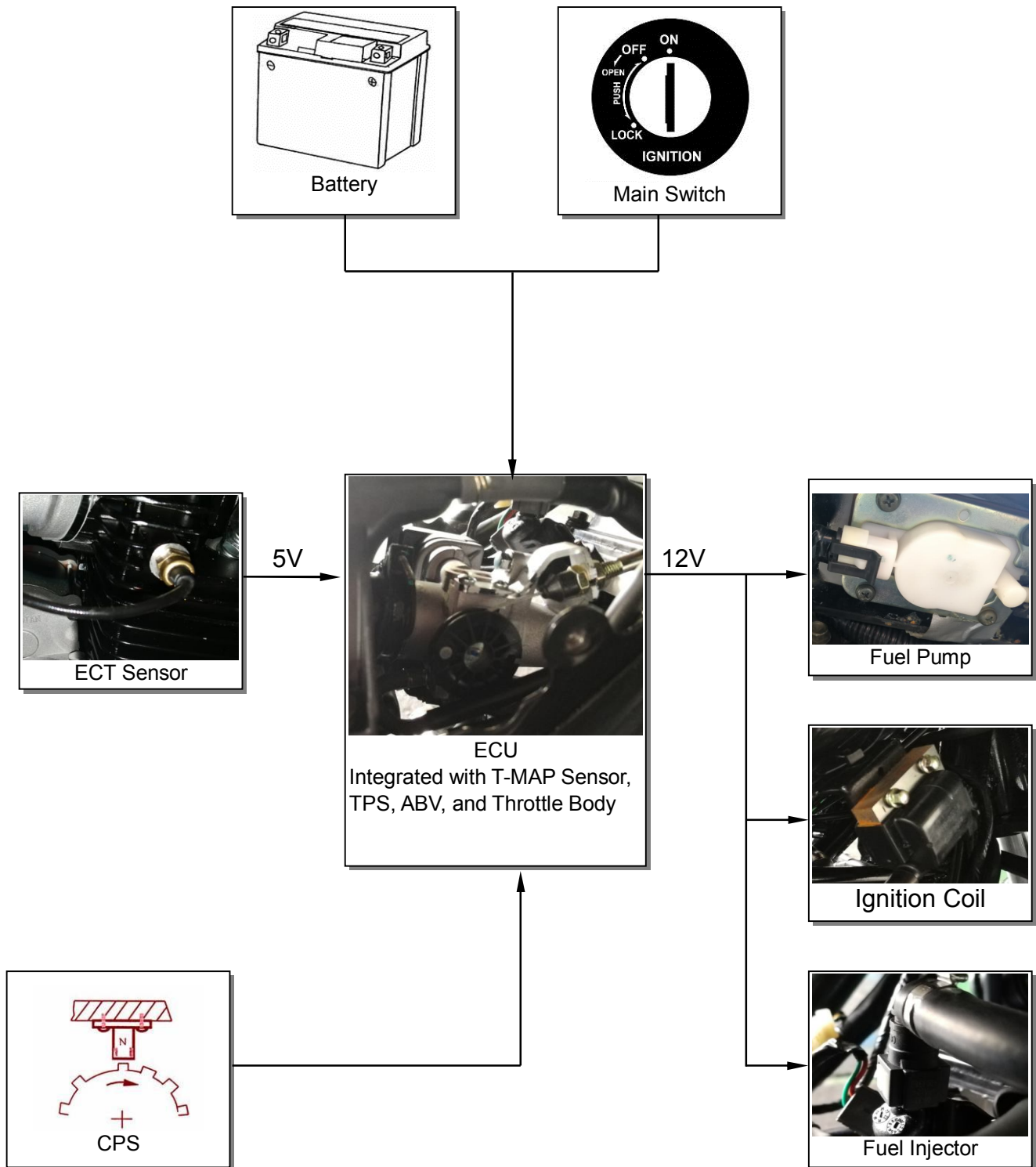

EFi System Component Description

Integrated ECU Module



Engine Control Unit (ECU)

- Powered by DC 8~16V, and has 32 terminals connector on the unit.
- The hardware component consists of an 16-bit computer that is its control center. It contains the functional circuit interface of engine condition sensing and the driving actuator for the air by-pass valve, fuel injector, and fuel pump, as well as transistor ignition coil.
- Its major software is a monitor strategy operation program that includes with controlling strategy, microarray profile and self-diagnosis programs.

Air Bypass Valve (ABV)

- Its major component is the solenoid valve of high resistance driven by electric current.
- By means of signals from all sensors, ECU outputs a signal to control the opening angle of the valve so that can adjust air flowing to the inlet manifold through the air by-pass valve, and then correct the idle speed to have engine in normal operation.

T-MAP Sensor

- The major component of the T-MAP sensor is a variable transistor IC. Its reference voltage is DC 5V, and output voltage range is DC 0~5V.
- It is a sensor of combination by both sensing pressure and temperature, and can measure the absolute pressure and temperature in intake process. It also conducts the fuel injection quantity correction based on environmental temperature and position level.

Throttle Position Sensor (TPS)

- Its major component is a highly variable resistor. The input voltage range: 5V DC.
- Located on the side of throttle body. By means of the throttle valve rotation to cause voltage change in linear, it provides ECU with current throttle valve openness information. And also, the ECU determines the most properly fuel injection and ignition timing.

Idle Speed Control Valve (stepper motor) :

- If it's mainly low-power DC motors, drives idle speed control valve (ISC) of the movement to adjust the idle air flow channel size, control of idle speed of the engine in the cold or hot.

Fuel Injector



- Powered by DC 8~16V, and has 2 terminals connector on the injector.
- Its major component is the solenoid valve of high resistance driven by electronic current.
- The two terminals are connected to power source and ground respective. It is controlled by ECU to determine the injection timing, and the injector pulse width. Working with 2-valve engine, the unique 2-hole designed injector can provide each intake valve with suitable fuel quantity to reduce HC emission.

Fuel Pump



- Powered by DC 8~16V, and has 2 terminals connector on the pump.
- The two terminals are connected to power source and ground respective. The ECU is to control and manage the operation of fuel pump through electrical power.
- Its major component is a driving fan pump that equipped with a low electrical consuming DC motor. Powered by 12V voltage and keep fuel pressure inside the fuel pump in 2.5 bars, which can offer 14 liters of fuel per hour.
- The fuel pump is located inside of the fuel tank, and installed a filter in front of its inlet so that can prevent from foreign materials sucking into the fuel pump to damage it and the fuel injector.

Ignition Coil



- Powered by DC 8~16V, and has 2 terminals connector on the coil.
- The two terminals are connected to power source and ground respective. Its major component is the high transferring rate transformer.
- Its ignition timing is controlled by computer program. From the signals of crankshaft position sensor, throttle position sensor, and engine temperature sensor as well as intake air temperature sensor, and correspondence with engine speed, then the ECU determines the ignition timing properly by means of controlling primary current in ON & OFF operation to create the secondary voltage of 25000~30000V. And then, the voltage triggers the spark plug ignition. Such kind of ignition system not only can enhance engine performance to maximum, but also increases fuel consumption efficiency and improves emission quality.

ECT Sensor

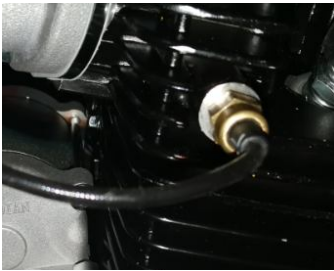

- Powered by 5V DC from ECU, and has 2 terminals connector on the sensor. One terminal is for voltage output and the other one for ground.
- Its major component is the thermo-resistance of negative temperature coefficient (temperature rises up while resistance falls down).
- Located on the cylinder head. Correspondence with engine coolant temperature change, it transferred to voltage signal and sent to ECU to calculate current temperature. Then, the ECU will correct fuel injection time and ignition timing according to engine warm up condition.

CPS

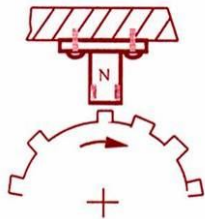

- It does not need power supply, and has 2-signal terminals connector on the sensor.
- Its major component is the magnetic pickup coil, and its output voltage range is $\pm 0.8 \sim 100V$.
- The air gap between the sensor and flywheel must have $.07 \sim 0.9mm$.
- By cutting the magnetic field, the magnetic sensor sends an inductive voltage that is created with the rotation gear (24-1 tooth) on the flywheel, and the pulse will be sent to the ECU. Then, the ECU calculates current engine speed and crank position based on the voltage so that controls fuel injection quantity and ignition timing properly.

O2 Sensor



- Powered by DC 8~16V, and has 1 terminals connector on the sensor. the one is for signal output.
- The O2 sensor feeds signal to ECU, and the ECU can control the air/fuel rate around 14.6. It's a close-loop control system.
- The catalytic converter reaches the best converting rate when this 14.6 A/F ratio is maintained.
- The heating coil resistance $< 200k\Omega$ (30—45k Ω)

EFi System Circuit

EFi System Circuit

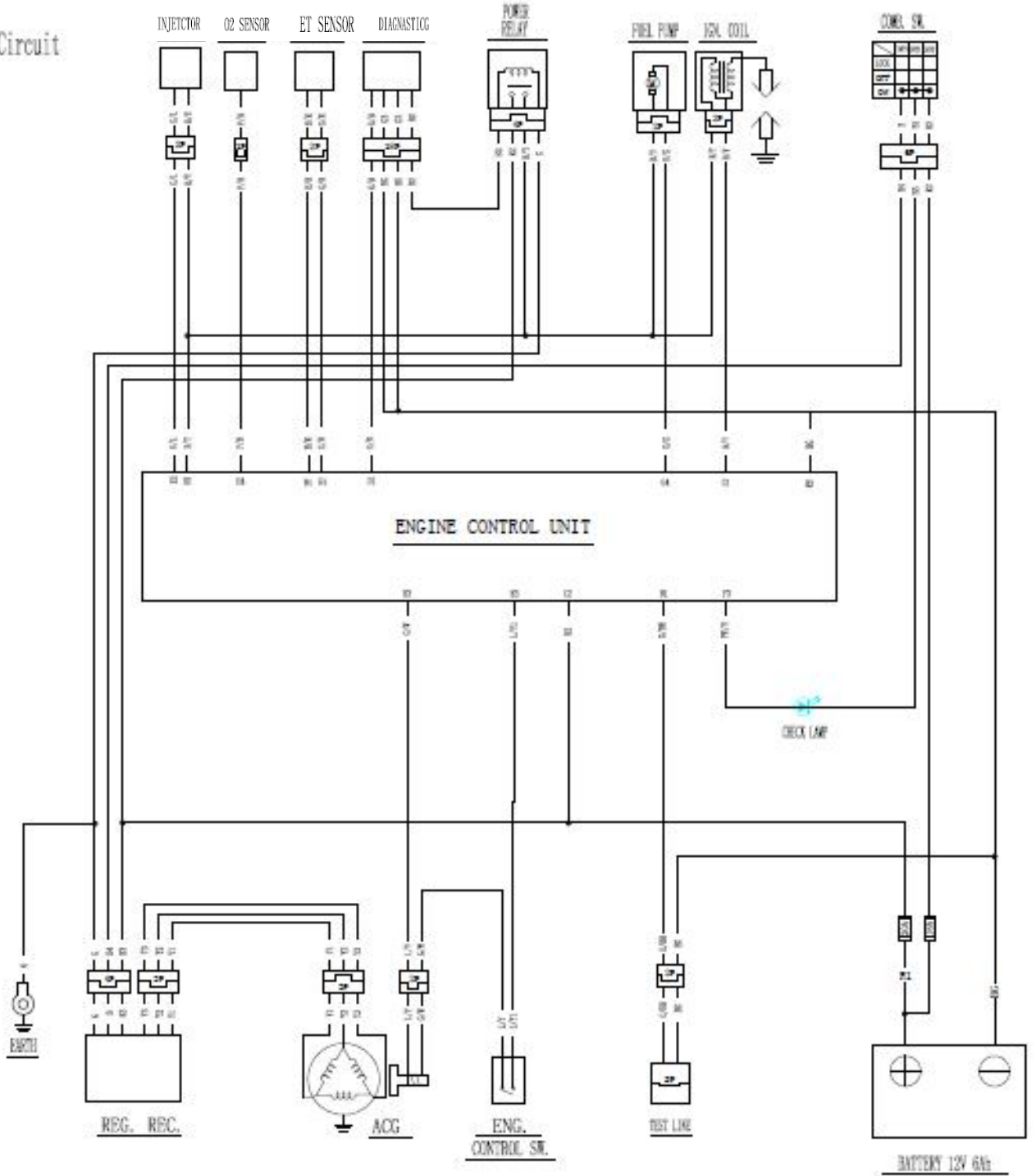

Precautions in Operation

General information

Warning

- Gasoline is a low ignition point and explosive materials, so always work in a well-ventilated place and strictly prohibit flame when working with gasoline.
- Release the fuel pressure before removing the fuel pipe to prevent splashing the fuel.

Caution

- Do not bend or twist throttle cable. Damaged cable will make unstable drive ability.
- When disassembling the fuel system parts, pay attention to O-ring position, replace with new one as re-assembly.

Fuel pressure release procedure:

Disconnect the fuel pump relay, switch on and press the start switch for a few seconds to crank the engine.

Specification

Item	
Idle speed	1700±100 rpm
Throttle grip free play	2~6 mm
Fuel pressure	2.5 bar

Torque value

Engine temperature sensor : 0.74~0.88 kgf-m

O2 sensor : 3.6~4.6 kgf-m

Special tools

Injection system diagnostic tool

Troubleshooting

EFI circuit inspection

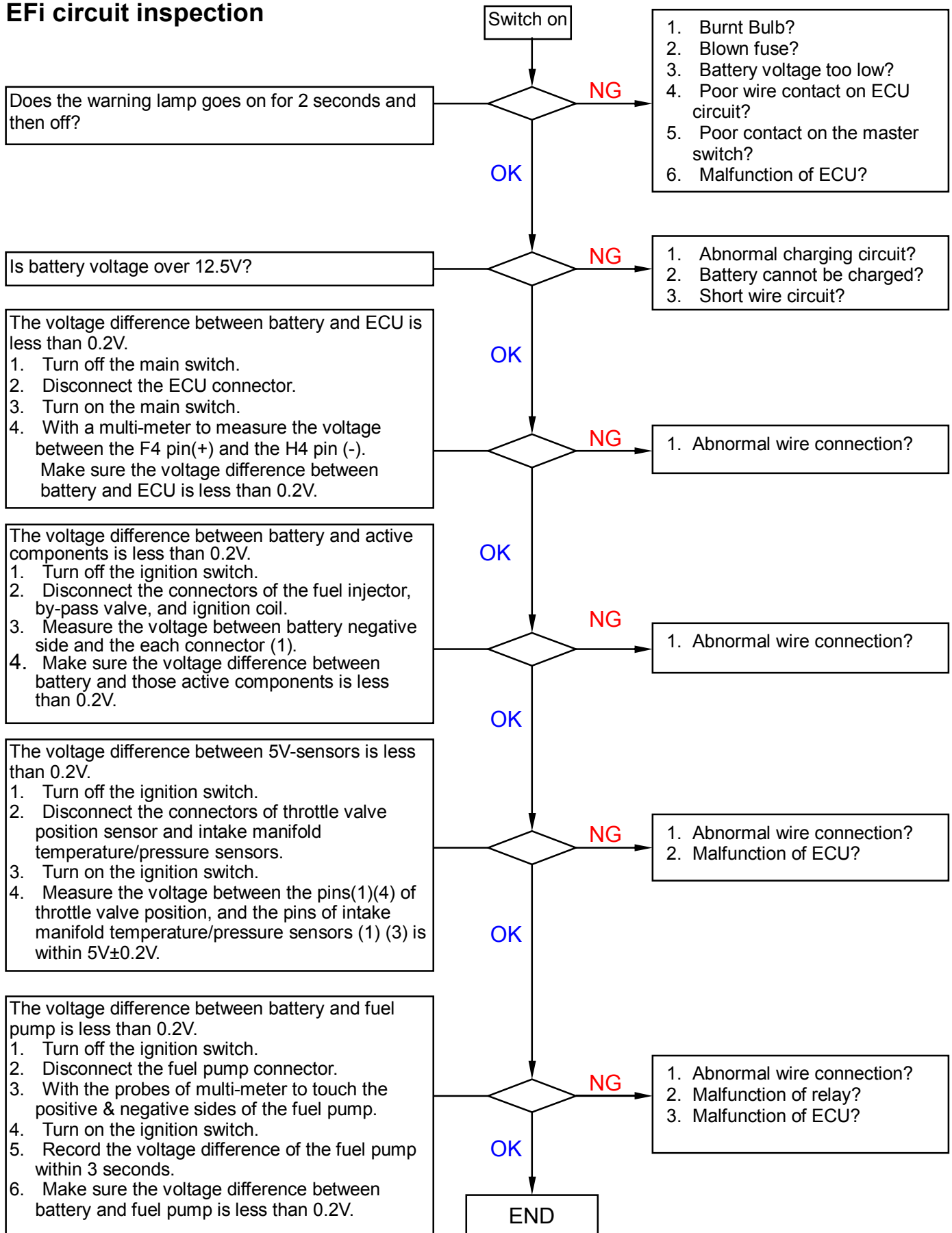

Engine cannot be started or difficult to start.

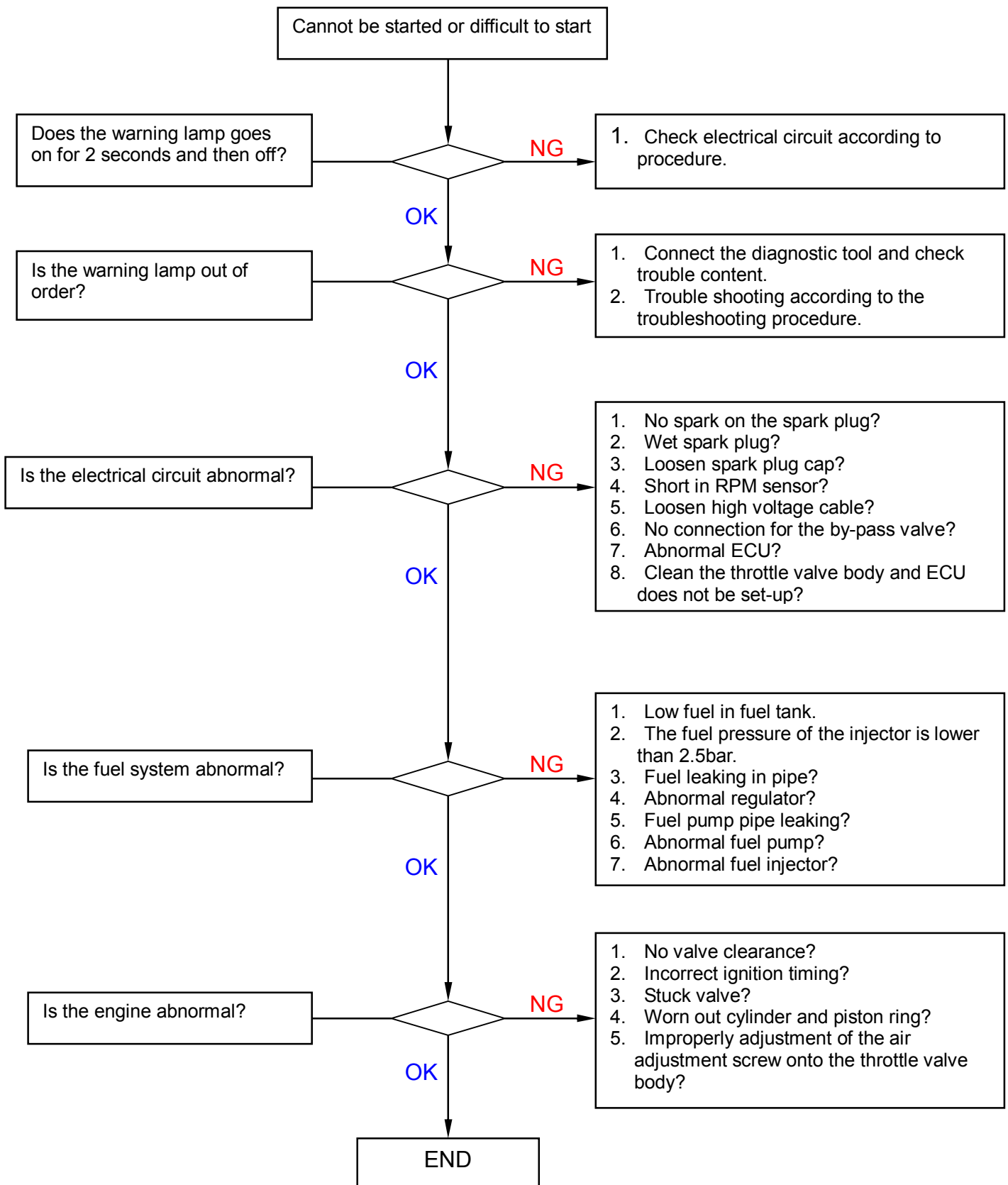

Diagnosis of Idle Speed Misfire

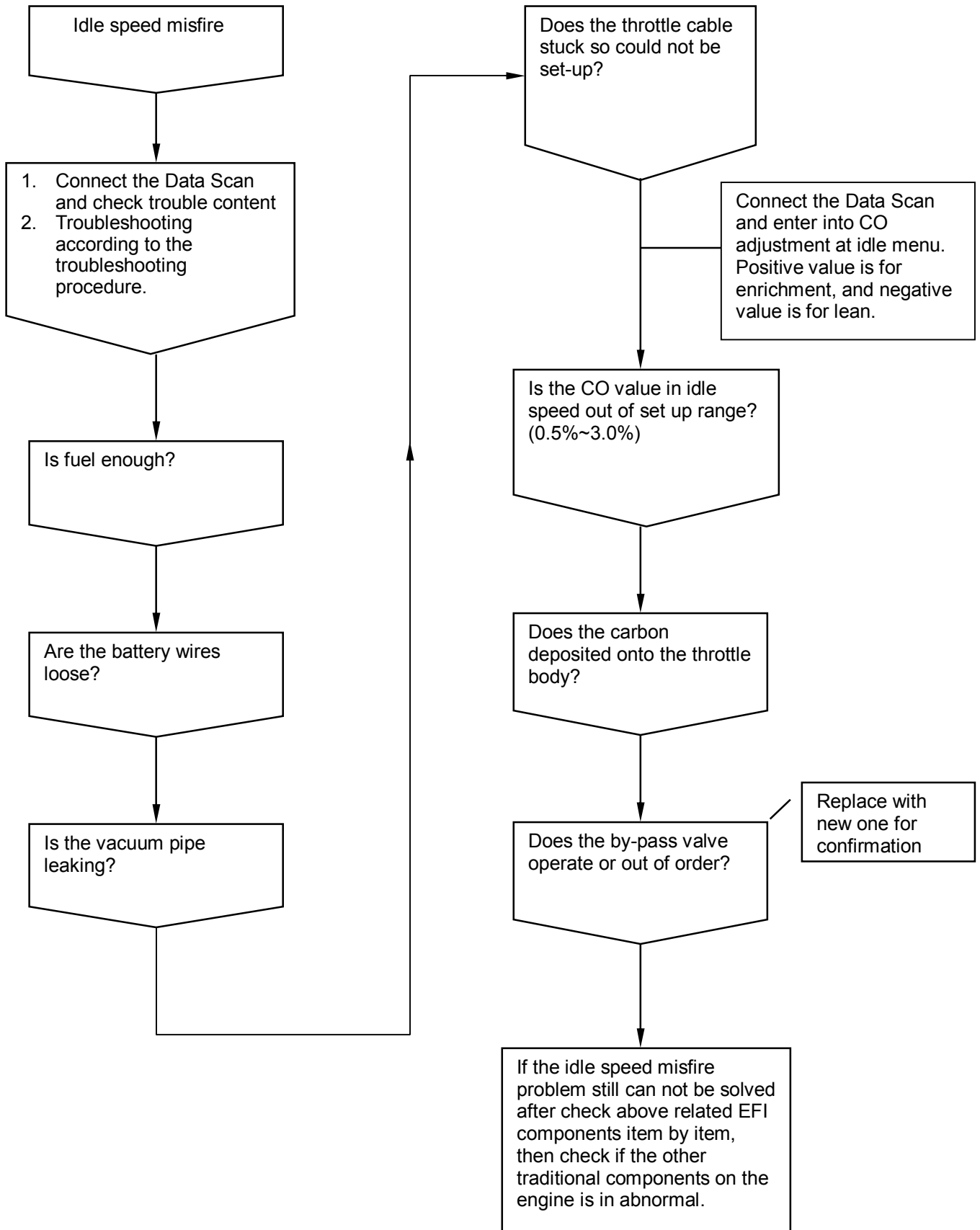

Abnormal CO value

If the system has O2 sensor, the CO value doesn't have to be adjusted. If the CO value still goes abnormal, please check O2 sensor first, to see if any malfunction occurred.

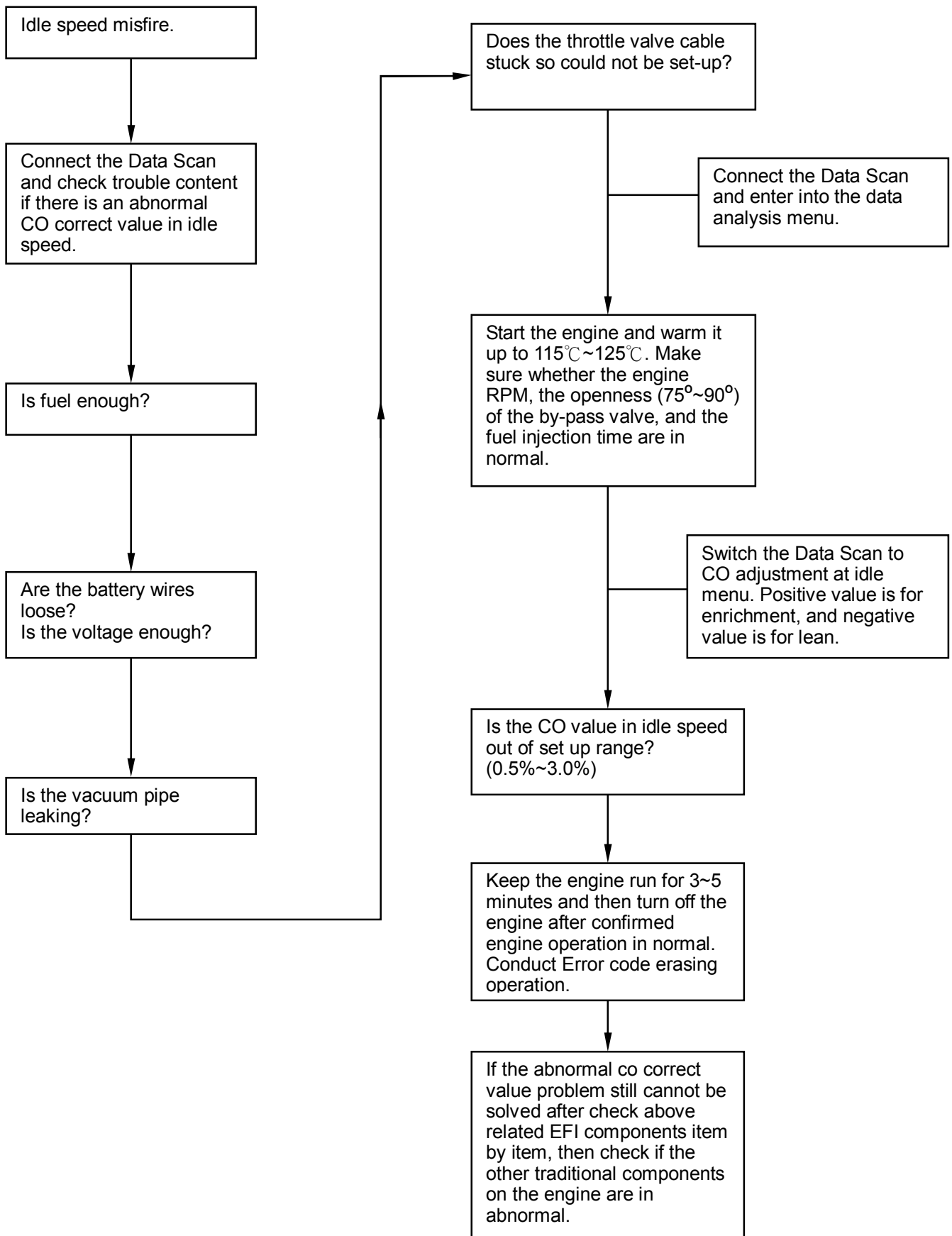

Throttle Body & By-pass Valve Clean Procedure



- It's suggested that clean the air by-pass valve before cleaning the throttle body.
- Recommended cleaning frequency: every 6000 km.

Clean procedure:

1. Air by-pass valve :

1. Switch off; disconnect the air tube between the air by-pass valve and connecting pipe.
2. Turn on the engine and keep the idle speed.
3. Spray a little carburetor cleaner into the air by-pass vale for 3~5 minutes. Do not shut down the engine during cleaning.
4. Connect the air tube.

2. Throttle body:

1. Switch off; remove the throttle body.
2. Spray a little carburetor cleaner into the throttle body.
3. Wipe off the dirty oil with clean cloth or tissue.
4. Dry the throttle body with compressed air and install the throttle body. Connect the diagnostic tool and switch on.

Idle speed learning:

After performing air by-pass valve or throttle body cleaning, idle speed learning should be carried out to let ECU know the engine condition well.

When performing the idle speed learning, run the engine at idle speed over 10 minutes after the engine temperature reaches the working temperature (around 70°C~95°C), and then ECU will get the parameters from sensors.

5. Fuel Injection System

SYM

Fuel Lines

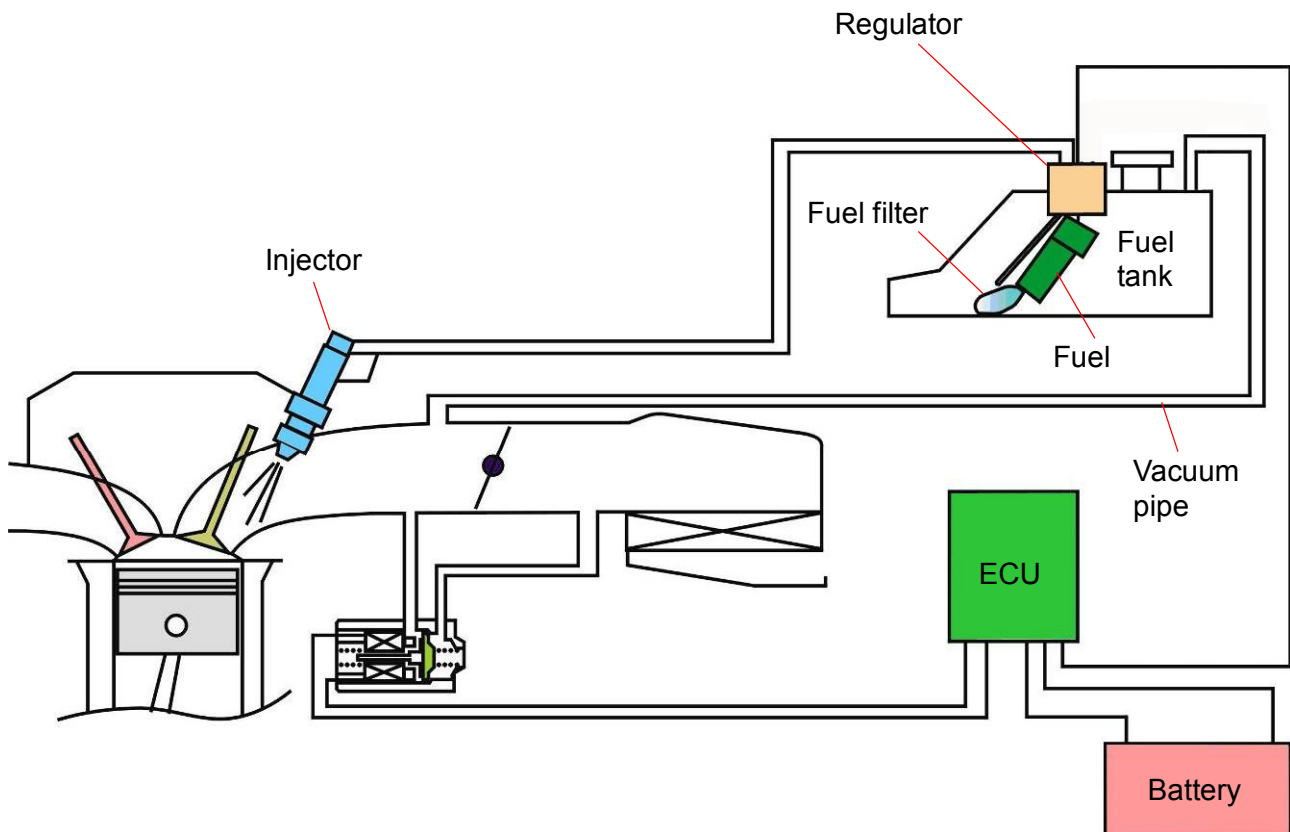

System description:

1. After key-on, all sensors' signals sent to the ECU first. The electrical fuel pump will be activated by ECU signal. If the engine did not start for 2~3 seconds, then the fuel pump will be turned off to save electricity. The pressure regulator maintains the fuel pressure around 2.5 Bar, and the fuel injector spray proper fuel quantity according to the conditions and environmental coefficient. When key-off or engine stopped, the fuel pumps stop operating.
2. The fuel filter is to filter alien materials so it has to be replaced regularly.
3. Do not let the starting motor keep running when the engine cannot start. It will cause battery voltage to decrease. If the voltage drops under 8V, the pump will not operate. The countermeasure will be starting the engine by connecting a new battery or with kick-starter.

Ignition System

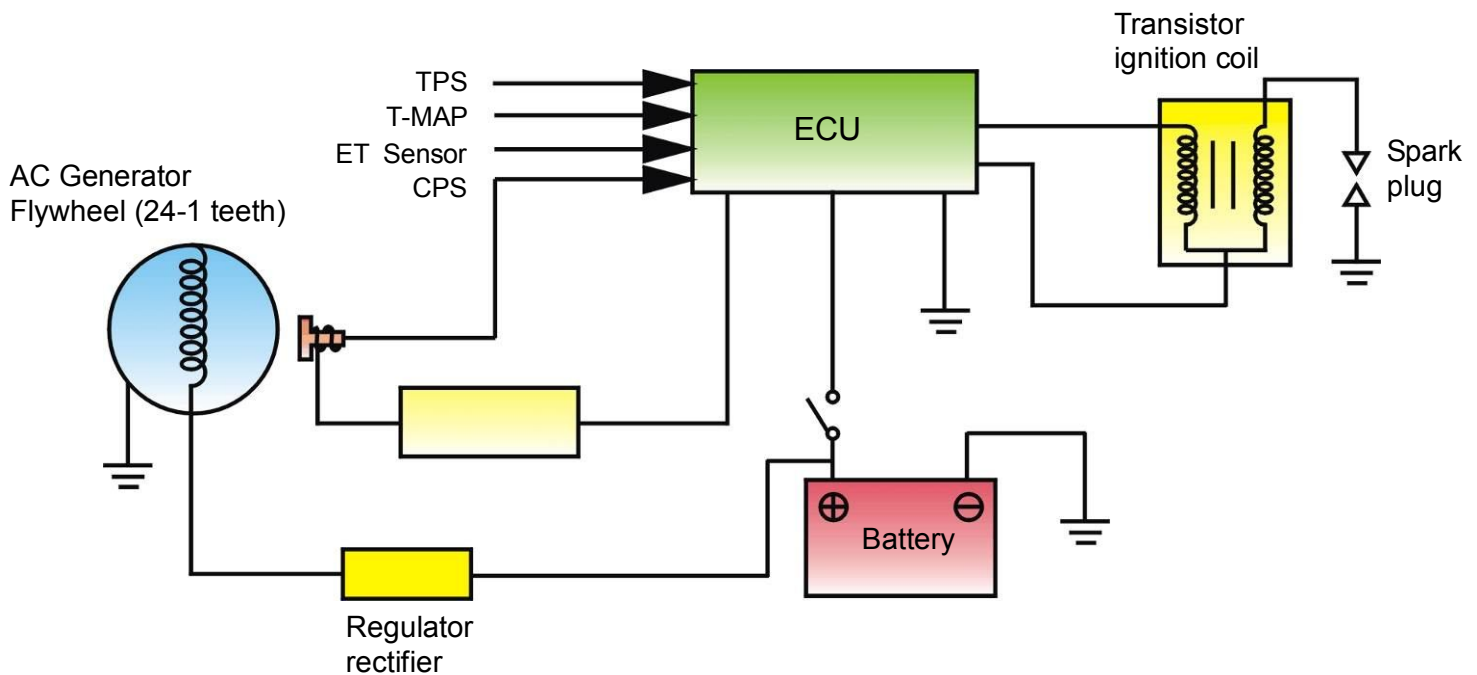

Principle of operation

The engine is equipped with a computerized ignition control system that collects signals from CPS, TPS, ET Sensor, and T-MAP Sensor. Then, correspondence with engine RPM, this 8-bit microcomputer in the system controls ignition timing properly. The secondary coil creates 25000~30000V high voltage to ignite the spark plug by means of the transistor operation of the primary current entry from the ECU. This can maximize engine performance and also decrease fuel consumption.

Specification

1. Ignition timing: BTDC 10° / 1700RPM
2. Spark plug: CPR8EA-9
3. Gap: 0.8mm
3. CPS pulse generator coil: 80~160 Ω / 20°C (G/W-LY)
4. Ignition coil
Primary circuit : 0.63±0.03 Ω (23°C)
5. Battery:
Capacity: 12V 6Ah

Crankshaft Position Sensor

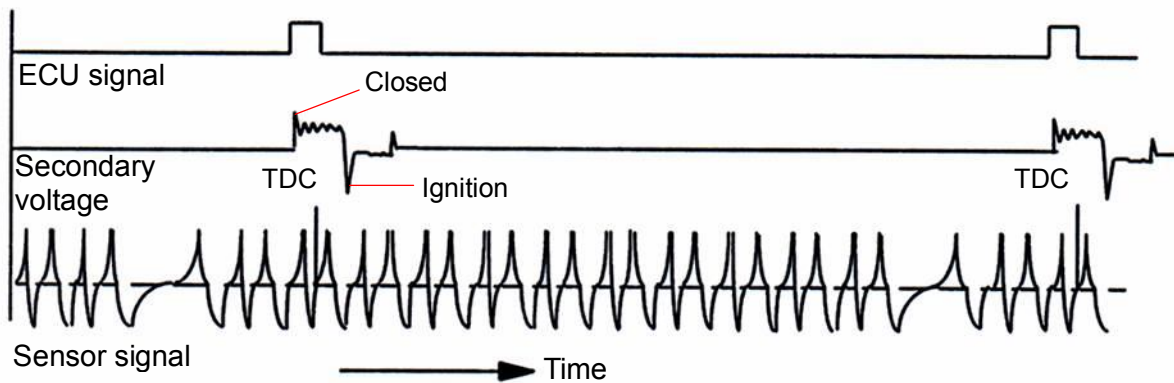
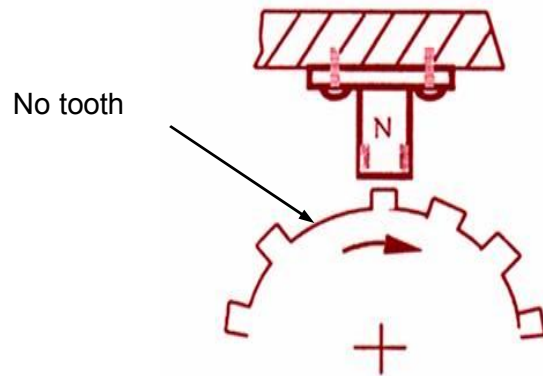

Description:

The magnetic field type sensor generates a voltage signal to calculate engine speed with ACG gear ring (24-1 tooth).

There is one tooth every 15 degree on the gear ring. But, one of the teeth is blank for the TDC calculating base.

Engine Temperature Sensor / T-Map Sensor

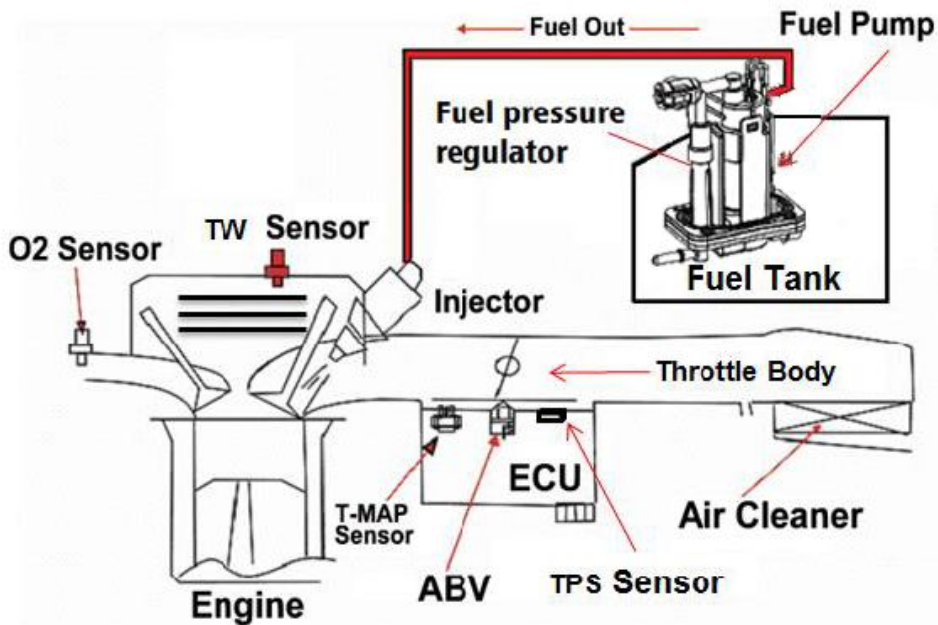

Engine temperature sensor:

According to the semiconductor's characteristic, the sensor detects the temperature of engine oil and metal parts and then sends a voltage signal to the ECU. On this base, the ECU can correct fuel injection and ignition timing.

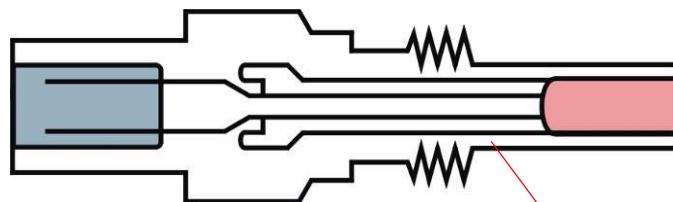

NTC- Negative Temperature Coefficient Resistor

T-MAP Sensor :

Sensor combined both pressure and NTC can detect the absolute pressure and temperature in the intake manifold, and then provides the ECU with signal for adjustment fuel injection quantity based on environmental temperature and air pressure difference from elevation level change.

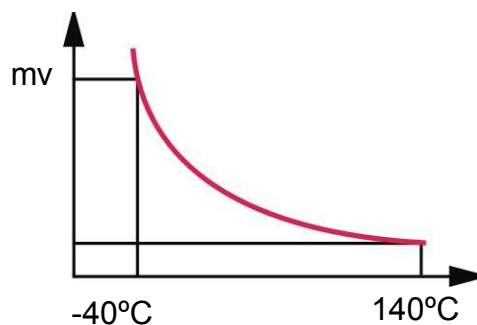

Air By-pass Valve

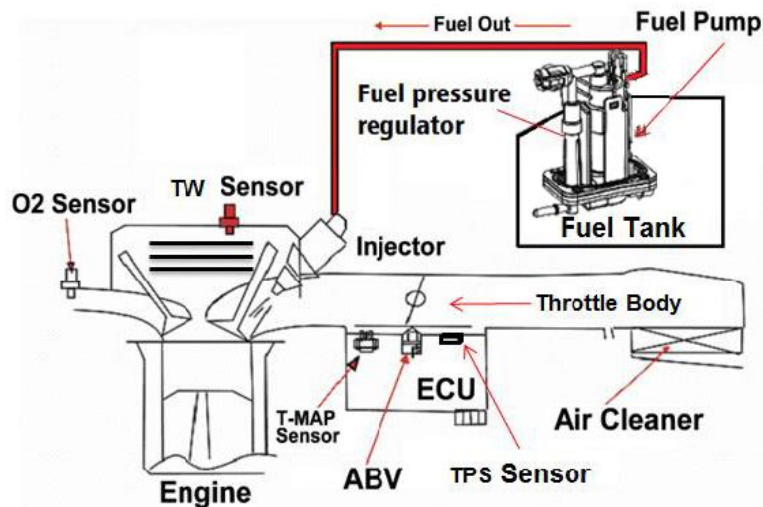

Description:

ECU receives all sensors' signals to control the throttle valve openness with PWM, and adjust airflow through the by-pass valve of the intake manifold. It can adjust idle speed for a stably running engine.

1. When engine cold starting---the by-pass valve open for a while to increase airflow and to stabilize engine idle speed within initial starting
2. Warm-up---when engine oil is in low temperature condition, the by-pass valve adjusts airflow according to engine temperature (engine oil temperature), and raises idle speed.
3. Speed decreasing--- ECU controls the by-pass valve in correspondence with throttle operation, to provide inlet pipe with proper airflow quantity. Such operation will smooth the engine rpm reduction process, preventing the engine from stalling, excessive negative pressure, and also reduce HC emission.

Fuel Injector

The injector provides intake valve a fuel jet. This can reduce the pollution of HC. The shortened version of fuel pump plate makes its size more compact, and sturdier against shocks. ECU signal controls the regulator to maintain 2.5 bars between the fuel pressure and the air pressure of inlet pipe. Through controlling the time length of injection under steady fuel pressure, the system can optimize the fuel injection quantity according to different engine workloads.

Fuel Pump

Electrical fuel pump is mounted inside the fuel tank. The power source is DC current provided and controlled by ECU; the pump can provide 14L/hour under the pressure of 2.5 bars.

Inspection :

Disconnect the fuel pipe from the fuel injector.
Connect the fuel pressure gauge to check the fuel pressure.

⚠ Caution

- Make sure the fuel pressure is normal (2.5 bar).
- Always release the fuel pressure before removing the fuel pipe to prevent the fuel from splashing.

Special tool :**Fuel pressure gauge SYM-HT07010**

Replace the fuel pump with new one if malfunction is confirmed.

Fuel Tank**Removal**

Disconnect the fuel pump and the fuel unit coupler.

Remove fuel pipe.

Remove the fuel cut valve pipe.

Remove the fuel tank

Installation

Install in the reverse order of removal.

⚠ Caution

- Make sure the fuel in the tank is not too much before removing the fuel tank.
- Replace the fuel tank if there is any damage or leakage.

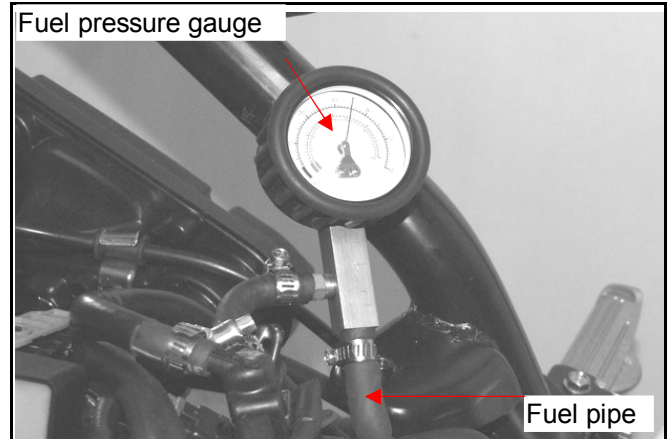

EFi Troubleshooting and Solution

•Electronic fuel injection (EFi) system fault warning light

After the main switch is on, the EFi indicator will be light. If the vehicle existing problems, the EFi indicator will light up all the time after the electrical starter button is on. When the problem is eliminated, restart the electrical starter button, the EFi indicator will light out automatically.

Error Code Message and Solution Operation

DTC code	OBD P-Code	Service priority	Message	Solution operation
P0217	P0217	1	Engine temperature overheat	Stop the vehicle immediately, and solve it with priority. Check the lubricant system for malfunction. Check if the ignition or fuel supply system is in normal. Check if the engine is burnt. Make sure if the engine temperature sensor is in normal. Make sure if the connector is in normal.
P0335	P0335	2	Abnormal crankshaft position sensor	Check if the connection of the crank position sensor is open-circuit. Check if the gap between the sensor and gear tooth is within specification. Check if the crank rotation is run-out. Check if the sensor is in normal according to the new component replacement procedure.
P0120	P0121	2	Abnormal throttle position sensor learning value	Connect the diagnostic and reset the throttle valve position. Make sure if the idle speed position is within standard range. Make sure if the wire circuit of the throttle valve position sensor is loosen or short. Check if the openness of idle speed by-pass valve is within specification. (40~100%) Adjust the idle speed CO value to specified range. (0.5%~2.0%) If this problem symptom still existing, check if the throttle position sensor (TPS) is in normal according to the new
P0121	P0123	2	Abnormal throttle position sensor output voltage	Make sure if the wire circuit of the throttle valve position sensor is loosen or short. If this problem symptom still existing, check if the throttle position sensor (TPS) is in normal according to the new component replacement procedure.
	P0122			
P0124	P0124	2	Abnormal throttle position sensor turning speed	Make sure if the wire circuit of the throttle valve position sensor is loosen or short. If this problem still existing, check if the throttle position sensor (TPS) is in normal according to the new component replacement procedure.
P0560	P0560	1	Abnormal battery voltage	Make sure if the battery voltage is too low or high (below 10V or exceed 16V) Make sure if the ACG generator charging system circuit is short or abnormal. Check the terminal on the ECU to battery positive post is short. Make sure if the battery is in normal. Replace it with new if the battery is out or order.
P0110	P0113	2	Abnormal intake air temperature sensor	Make sure if the sensor's wire is in open-circuit. Make sure if the sensor is normal according to the new component replacement procedure.
	P0112			
	P0114			

DTC code	OBD P-Code	Service priority	Message	Solution operation
P0506	P0509	2	Abnormal air bypass valve learning value	Check if the air bypass valve openness is in normal. Check if the intake manifold is leaking.
	P0508			
P0200	P0262	2	Abnormal fuel injector	Make sure if the fuel injector resistance is within specification. (12 Ω, 20°C) Check if the connector or wire is in open-circuit. (The G1 terminal of ECU) Make sure if the fuel injector power supplied is normal. (12~15V)
	P0261			
P0350	P2301	2	Abnormal ignition circuit	Make sure if the ignition coil resistor is within specification. (0.63 Ω, 23°C) Make sure if the connector or wire is in open-circuit. (The 12th terminal of ECU) Make sure if the ignition coil's power supplied is in normal. (12~15V)
	P2300			
P0219	P0219	2	Engine over-RPM	Engine speed exceed safety limit. Decrease the speed and then the DTC code disappeared. Check if the CVT belt is broken.
P0700	P0894	2	Too high RPM when starting engine	If the engine RPM exceeds 3000rpm as starting, in order to prevent run-away accident, the ECU will decrease engine speed or stop the engine. Rider should avoid to starting engine with WOT suddenly. Check if acceleration cable is stuck. Re-set the idle speed adjustment position.
P0115	P0118	2	Abnormal engine temperature sensor	Make sure if the sensor's resistor is within specification. (60°C, 703.8±40.9Ω) Make sure if the sensor's wire is in open-circuit. (9th terminal of ECU)
	P0117			
	P0119			
P0650	P0650	2	Abnormal check lamp	Check if the check lamp is burnt. Check if the check lamp circuit is open. (C2 terminal of ECU)
P0136	P0132	2	Abnormal O2 sensor wiring	Check O2 sensor coupler. Check O2 sensor wiring (D2, D1 terminal of ECU).
	P0131			
	P0134			
P0141	P0108	2	Abnormal O2 sensor heater wiring	Check O2 sensor coupler. Check O2 sensor wiring (H1 terminal of ECU). Check O2 sensor white cable voltage (12V).
	P0107			

DTC code	OBD P-Code	Service priority	Message	Solution operation
P0170	P0171	2	Abnormal reset coupler	Check the coupler wiring.
	P0172			
	P0172			

ECU coupler terminal layout :

X10	X11	X12	X13	X14	X15	X16	X17	X18
Ignition coil	MIL	(H)EGO Sensor	Crank Pulse Sensor (+)	VBD	CHTS	Veh Speed	Neutral switch / Side stand switch	Fuel pump
PGND	Temperature gauge	SAI / CPV	Crank Pulse Sensor(-)	HEGO heat / Fan relay	Tilt switch	VBK	Diagnostic Tool / K-line	Injection
X1	X2	X3	X4	X5	X6	X7	X8	X9

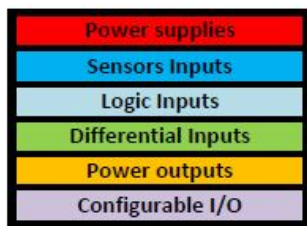

Connector Power slots

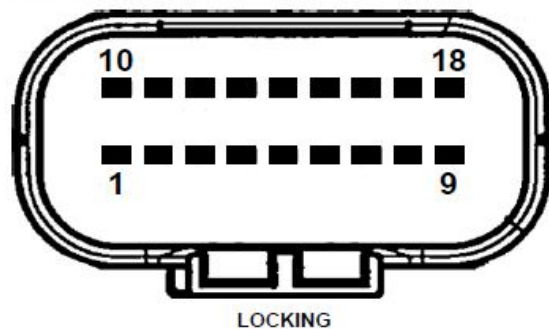

M4L pin insertion connector front view
 JAE reference for development connectors :
 MX23A18NF2 (reverse type)

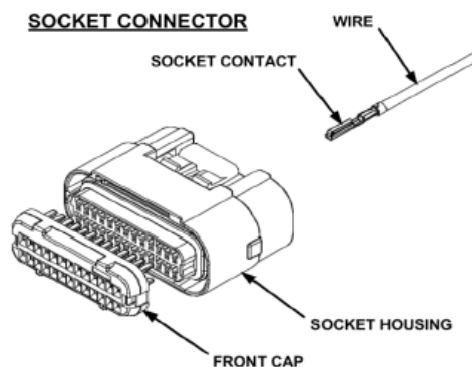

EFi System Diagnosis Methods

When the motorcycle injection system in the wrong signal, causing abnormal functioning of the engine or can not start engine, warning light at the meter will be lighting, to inform drivers to carry out maintenance. Overhaul, the diagnosis tool can be used for troubleshooting (refer to diagnosis tool use guide), or manually by the meter warning light inspection revealed that the fault codes (refer to checking signal fault codes discriminant method), the two methods for maintenance. If the fault has been ruled out or repair after the inspection light will be extinguished, but ECU fault code will be recorded, so the need to get rid of fault codes. If a fault exists, this system has two kinds of methods to eliminate fault codes respectively in the diagnosis tool removal and manual removal.

Injection System for Use diagnosis - V70

**Note:**

- When problems arise, can be used for diagnosis tool of the fault is detected, and exclusion.
- In addition to testing, troubleshooting, another of the operation can be carried out data analysis-type monitor.

Method of Use:

1. Maintain engine flameout state, do not open main switch.
2. Opened the luggage box lighting light cover (screw x2), connected to the diagnostic connector for diagnosis tool.
3. Then open the main switch and the diagnosis tool power switch after diagnosis display screen appeared the words connection.
4. Press the "ENTER" button into the main screen (there are 6 major functions: ECU ID, DATA STREAM, FREEZED DATA, TROUBLE CODE, ERASE TB CODE and CO ADAPTION)
5. Use ▲, ▼ select button under the function, press the "ENTER" button access into various functions.
Example: select "DATA STREAM," by the "ENTER" button, the screen showed that the existing fault codes; indicates no fault "system is OK."
6. Press "EXIT" button to leave of the various functions.
7. Must to close the main switch or power switch of the diagnosis tool after, and then can removal of diagnosis tool coupler.

Diagnostic tool illustration

Connect the diagnostic tool wire connector and turn on the main switch.

Press <Enter> button to proceed.



Press <Enter> button to enter function-options page.

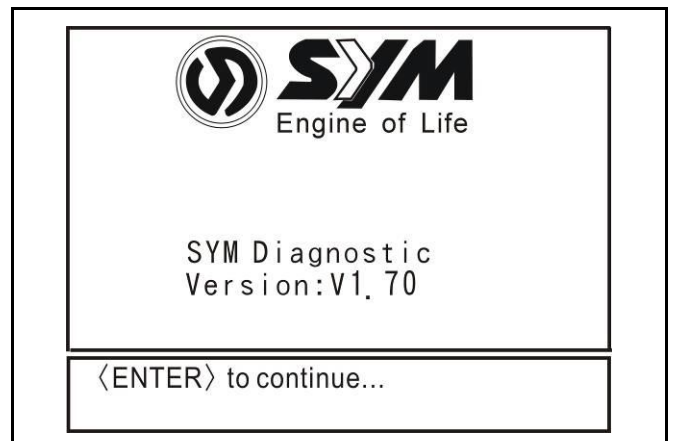

Press <Enter> button to enter ECU ID version page.

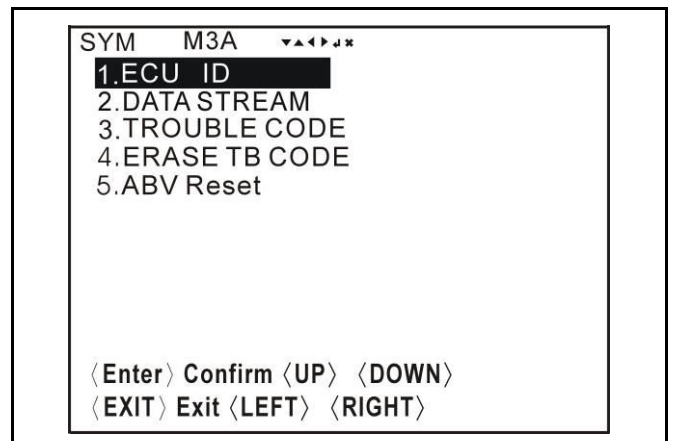

System Information

Press <Enter> button to get back to the function-options page.

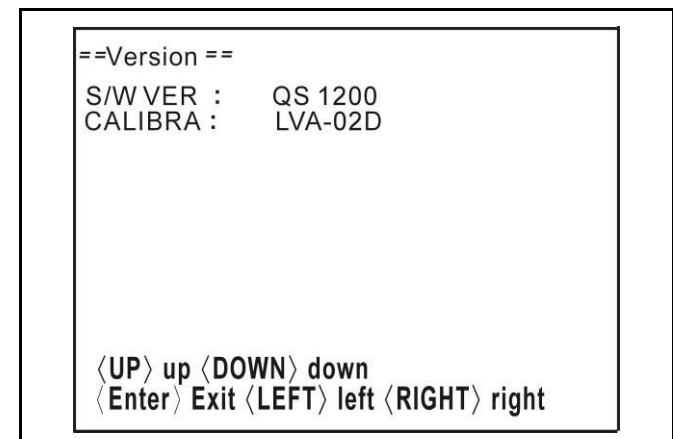

DATA STREAM

Press <Enter> button to enter Data Stream page.

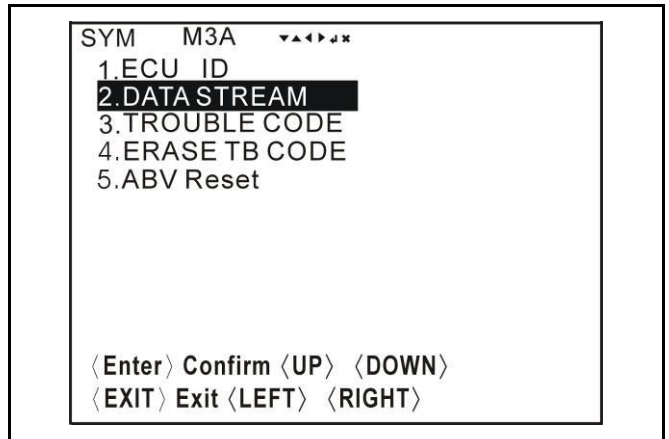

Press <UP> or <DOWN> button to choose Fault No. item.

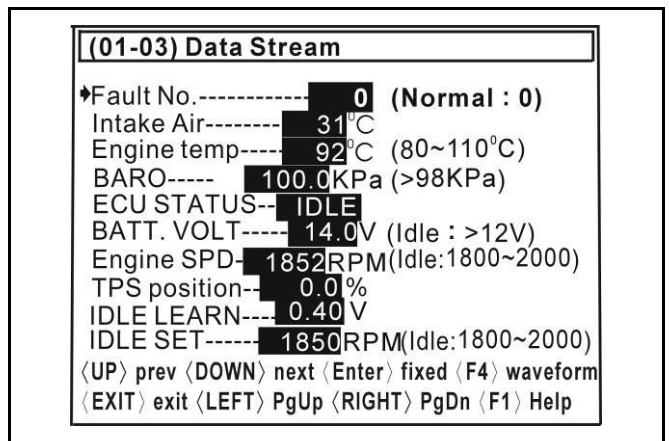

Press <F1> button to enter description page.
Press any key to get back to Data Stream page.

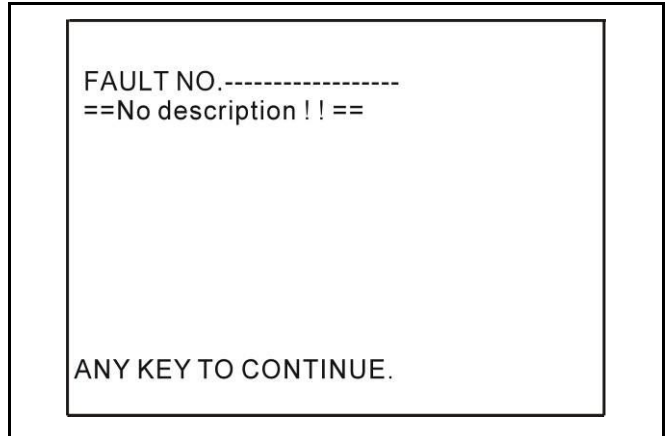

5. Fuel Injection System

SYM

Press <UP> or <DOWN> button to choose Intake Air item.

(01-03) Data Stream

Fault No.----- **0** (Normal : 0)
♦Intake Air----- **31**°C
Engine temp----- **92**°C (80~110°C)
BARO----- **100.0**KPa (>98KPa)
ECU STATUS-- **IDLE**
BATT. VOLT----- **14.0**V (Idle : >12V)
Engine SPD- **1852**RPM(Idle:1800~2000)
TPS position-- **0.0**%
IDLE LEARN--- **0.40**V
IDLE SET----- **1850**RPM(Idle:1800~2000)
<UP> prev <DOWN> next <Enter> fixed <F4> waveform
<EXIT> exit <LEFT> PgUp <RIGHT> PgDn <F1> Help

Press <F1> button to enter description page.
Press any key to get back to Data Stream page.

Intake Air-----
Measure the intake air temperature to convey to ECU, then the ECU calculate out proper compensation and controlling amount of injected fuel.

ANY KEY TO CONTINUE.

Press <F4> button to enter waveform page.
Press <EXIT> button to get back to Data Stream page.

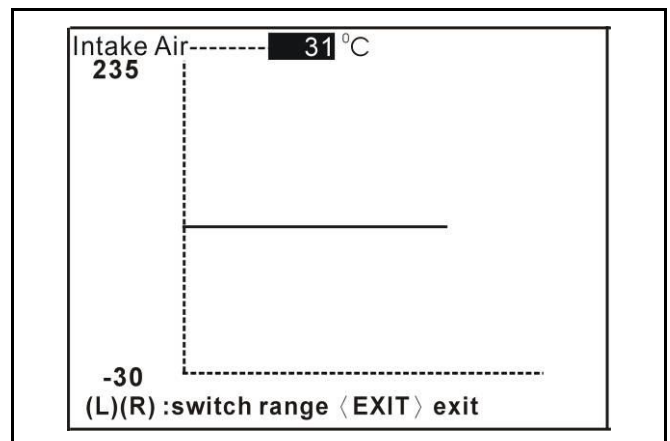

Press <UP> or <DOWN> button to choose Engine Temp item.

(01-03) Data Stream

Fault No.----- **0** (Normal : 0)
 Intake Air----- **31**°C
 ▶Engine temp----- **92**°C (80~110°C)
 BARO----- **100.0**KPa (>98KPa)
 ECU STATUS-- **IDLE**
 BATT. VOLT----- **14.0**V (Idle : >12V)
 Engine SPD- **1852**RPM(Idle:1800~2000)
 TPS position-- **0.0**%
 IDLE LEARN--- **0.40**V
 IDLE SET----- **1850**RPM(Idle:1800~2000)
 <UP> prev <DOWN> next <Enter> fixed <F4> waveform
 <EXIT> exit <LEFT> PgUp <RIGHT> PgDn <F1> Help

Press <F1> button to enter description page.
 Press any key to get back to Data Stream page.

Engine temp-----
 This data can be used for observing the engine been warm-ready or not. Some ECU control items need impleted in engine warm-ready status.

ANY KEY TO CONTINUE.

Press <F4> button to enter waveform page.
 Press <EXIT> button to get back to Data Stream page.

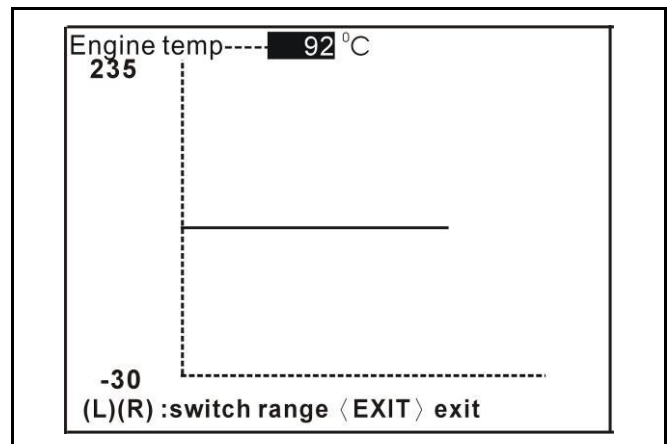

5. Fuel Injection System

SYM

Press <UP> or <DOWN> button to choose BARO item.

(01-03) Data Stream

Fault No.----- **0** (Normal : 0)
Intake Air----- **31**°C
Engine temp----- **92**°C (80~110°C)
▶BARO----- **100.0**KPa (>98KPa)
ECU STATUS-- **IDLE**
BATT. VOLT----- **14.0**V (Idle : >12V)
Engine SPD-- **1852**RPM(Idle:1800~2000)
TPS position-- **0.0**%
IDLE LEARN---- **0.40**V
IDLE SET----- **1850**RPM(Idle:1800~2000)
<UP> prev <DOWN> next <Enter> fixed <F4> waveform
<EXIT> exit <LEFT> PgUp <RIGHT> PgDn <F1> Help

Press <F1> button to enter description page.
Press any key to get back to Data Stream page.

BARO-----
Under different height above sea level, atmospheric pressure will lead to the fact air thin, so will need a compensation coefficient to the injected fuel.

ANY KEY TO CONTINUE.

Press <F4> button to enter waveform page.
Press <EXIT> button to get back to Data Stream page.

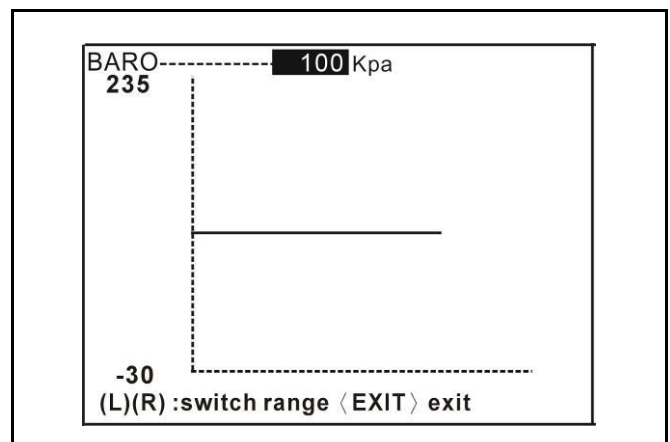

Press <UP> or <DOWN> button to choose BATT. VOLT item.

(01-03) Data Stream

Fault No.----- **0** (Normal : 0)
 Intake Air----- **31**°C
 Engine temp----- **92**°C (80~110°C)
 BARO----- **100.0**KPa (>98KPa)
 ECU STATUS-- **IDLE**
 ▶BATT. VOLT----- **14.0**V (Idle : >12V)
 Engine SPD- **1852**RPM(Idle:1800~2000)
 TPS position-- **0.0**%
 IDLE LEARN--- **0.40**V
 IDLE SET----- **1850**RPM(Idle:1800~2000)
 <UP> prev <DOWN> next <Enter> fixed <F4> waveform
 <EXIT> exit <LEFT> PgUp <RIGHT> PgDn <F1> Help

Press <F1> button to enter description page.
 Press any key to get back to Data Stream page.

BATT. VOLT-----

ECU measure the battery voltage pin. This pin connected to injector, igniter on coil and fuel pump circuit.

ANY KEY TO CONTINUE.

Press <F4> button to enter waveform page.
 Press <EXIT> button to get back to Data Stream page.

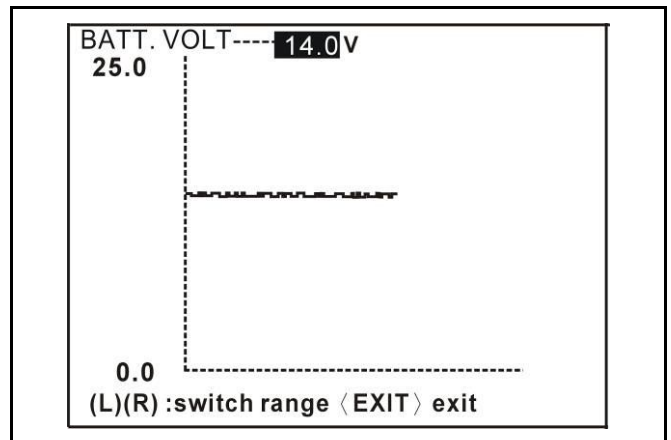

5. Fuel Injection System

SYM

Press <UP> or <DOWN> button to choose Engine SPD item.

(01-03) Data Stream

Fault No.----- **0** (Normal : 0)
Intake Air----- **31**°C
Engine temp----- **92**°C (80~110°C)
BARO----- **100.0**KPa (>98KPa)
ECU STATUS-- **IDLE**
BATT. VOLT----- **14.0**V (Idle : >12V)
→Engine SPD-- **1852**RPM(Idle:1800~2000)
TPS position-- **0.0**%
IDLE LEARN---- **0.40**V
IDLE SET----- **1850**RPM(Idle:1800~2000)
<UP> prev <DOWN> next <Enter> fixed <F4> waveform
<EXIT> exit <LEFT> PgUp <RIGHT> PgDn <F1> Help

Press <F1> button to enter description page.
Press any key to get back to Data Stream page.

Engine SPD-----
Utilize the crankshaft position sensor with the gear teeth to calculate out the engine RPM count.

ANY KEY TO CONTINUE.

Press <F4> button to enter waveform page.
Press <EXIT> button to get back to Data Stream page.

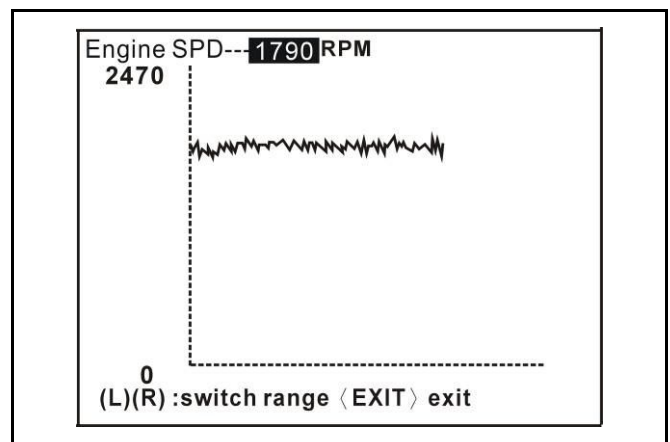

Press <UP> or <DOWN> button to choose TPS position item.

(01-03) Data Stream

Fault No.----- **0** (Normal : 0)
 Intake Air----- **31**°C
 Engine temp----- **92**°C (80~110°C)
 BARO----- **100.0**KPa (>98KPa)
 ECU STATUS-- **IDLE**
 BATT. VOLT----- **14.0**V (Idle : >12V)
 Engine SPD- **1852**RPM(Idle:1800~2000)
 ▶TPS position-- **0.0**%
 IDLE LEARN--- **0.40**V
 IDLE SET----- **1850**RPM(Idle:1800~2000)
 <UP> prev <DOWN> next <Enter> fixed <F4> waveform
 <EXIT> exit <LEFT> PgUp <RIGHT> PgDn <F1> Help

Press <F1> button to enter description page.
 Press any key to get back to Data Stream page.

TPS position-----
 This data is 0% in idle speed, 100% i
 n full speed.

ANY KEY TO CONTINUE.

Press <F4> button to enter waveform page.
 Press <EXIT> button to get back to Data Stream page.

TPS position---- **0.0**%
128.0

0.0
 (L)(R) :switch range <EXIT> exit

5. Fuel Injection System

SYM

Press <UP> or <DOWN> button to choose IDLE LEARN item.

(01-03) Data Stream

Fault No.----- **0** (Normal : 0)
Intake Air----- **31**°C
Engine temp----- **92**°C (80~110°C)
BARO----- **100.0**KPa (>98KPa)
ECU STATUS-- **IDLE**
BATT. VOLT----- **14.0**V (Idle : >12V)
Engine SPD- **1852**RPM(Idle:1800~2000)
TPS position-- **0.0**%
▶IDLE LEARN--- **0.40**V
IDLE SET----- **1850**RPM(Idle:1800~2000)
<UP> prev <DOWN> next <Enter> fixed <F4> waveform
<EXIT> exit <LEFT> PgUp <RIGHT> PgDn <F1> Help

Press <F1> button to enter description page.
Press any key to get back to Data Stream page.

IDLE LEARN-----
==No description !!==

ANY KEY TO CONTINUE.

Press <F4> button to enter waveform page.
Press <EXIT> button to get back to Data Stream page.

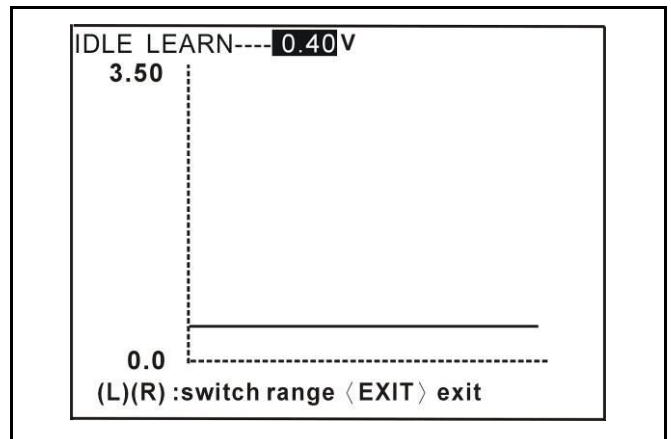

Press <UP> or <DOWN> button to choose IDLE SET item.

(01-03) Data Stream

Fault No.----- **0** (Normal : 0)
 Intake Air----- **31**°C
 Engine temp----- **92**°C (80~110°C)
 BARO----- **100.0**KPa (>98KPa)
 ECU STATUS-- **IDLE**
 BATT. VOLT----- **14.0**V (Idle : >12V)
 Engine SPD- **1852**RPM(Idle:1800~2000)
 TPS position-- **0.0**%
 IDLE LEARN--- **0.40**V
 *IDLE SET----- **1850**RPM(Idle:1800~2000)
 <UP> prev <DOWN> next <Enter> fixed <F4> waveform
 <EXIT> exit <LEFT> PgUp <RIGHT> PgDn <F1> Help

Press <F1> button to enter description page.
 Press any key to get back to Data Stream page.

IDLE SET-----

Utilize the engine temperature and intake air temperature to calculate out the idle speed RPM.

ANY KEY TO CONTINUE.

Press <F4> button to enter waveform page.
 Press <EXIT> button to get back to Data Stream page.

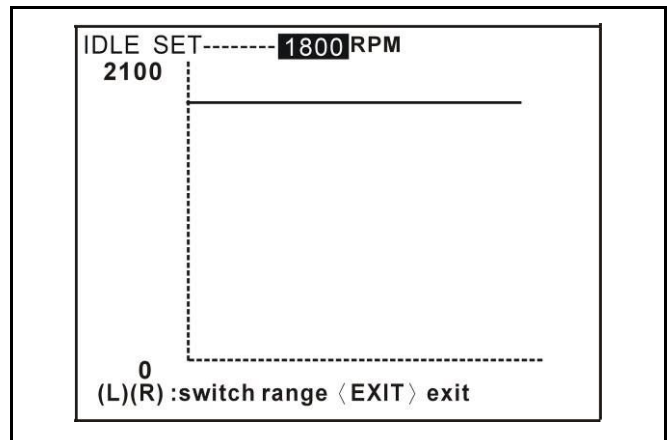

Press <RIGHT> button to get to next page to choose MAP item.

```

(02-03) Data Stream  < *
▶MAP----- 52Kpa (40~60 Kpa)
INJECT TIME---- 3.3ms (1.5~2.5 ms)
IGN. ANGLE---- 5.6° (8~18°)
IGN. CHARGE-- 3.36ms (2.5~4.0ms)
RUN TIME---- 5Hr
FUEL PUMP---- ON
TILTED SNSR--- 0.58V
BYPASS ADAPT-- -0.46° (-50~120°)
BYPASS LEARN-- 104.6°
BYPASS OPEN--- 19.2 (0~240°)
<UP> prev <DOWN> next <Enter> fixed <F4> waveform
<EXIT> exit <LEFT> PgUp <RIGHT> PgDn <F1> Help
    
```

Press <F1> button to enter description page.
Press any key to get back to Data Stream page.

```

MAP-----
This data used for measure manifold v
acuity to calculate fuel amount and i
gnition angle.

ANY KEY TO CONTINUE.
    
```

Press <F4> button to enter waveform page.
Press <EXIT> button to get back to Data Stream page.

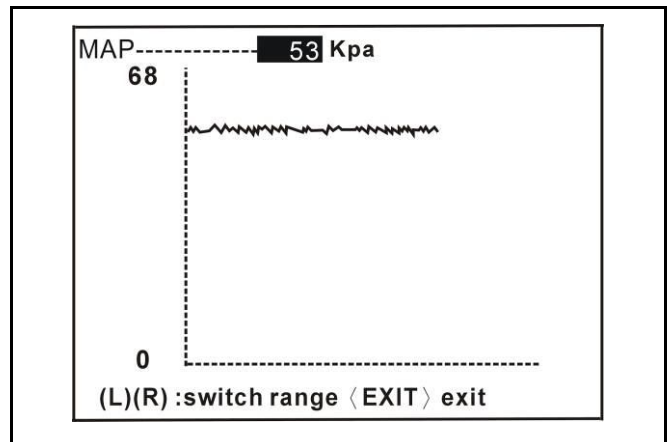

Press <UP> or <DOWN> button to choose INJECT TIME item.

```

(02-03) Data Stream  ←*
MAP----- 52Kpa (40~60 Kpa)
♦INJECT TIME---- 3.3ms (1.5~2.5 ms)
IGN. ANGLE---- 5.6° (8~18°)
IGN. CHARGE-- 3.36ms (2.5~4.0ms)
RUN TIME---- 5Hr
FUEL PUMP---- ON
TILTED SNSR--- 0.58V
BYPASS ADAPT-- -0.46° (-50~120°)
BYPASS LEARN-- 104.6°
BYPASS OPEN--- 19.2 (0~240°)
<UP> prev <DOWN> next <Enter> fixed <F4> waveform
<EXIT> exit <LEFT> PgUp <RIGHT> PgDn <F1> Help
    
```

Press <F1> button to enter description page.
Press any key to get back to Data Stream page.

```

INJECT TIME-----
ECU set the injetter ON time interval
, it also means the injected fuel val
ue.

ANY KEY TO CONTINUE.
    
```

Press <F4> button to enter waveform page.
Press <EXIT> button to get back to Data Stream page.

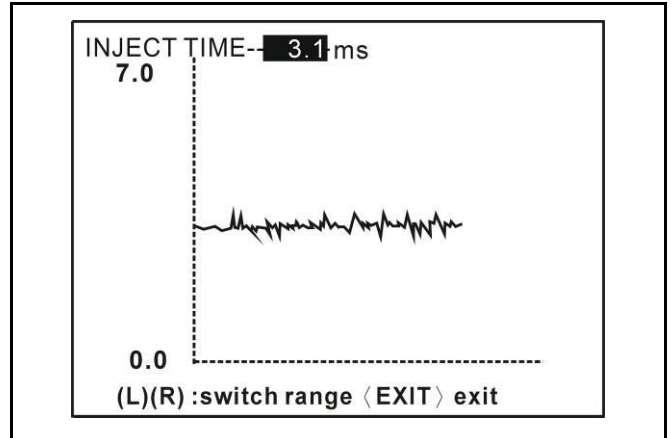

5. Fuel Injection System

SYM

Press <UP> or <DOWN> button to choose IGN. ANGLE item.

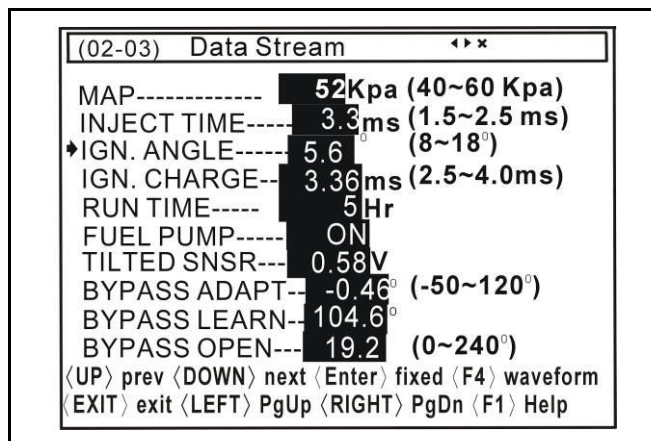

Press <F1> button to enter description page.
Press any key to get back to Data Stream page.

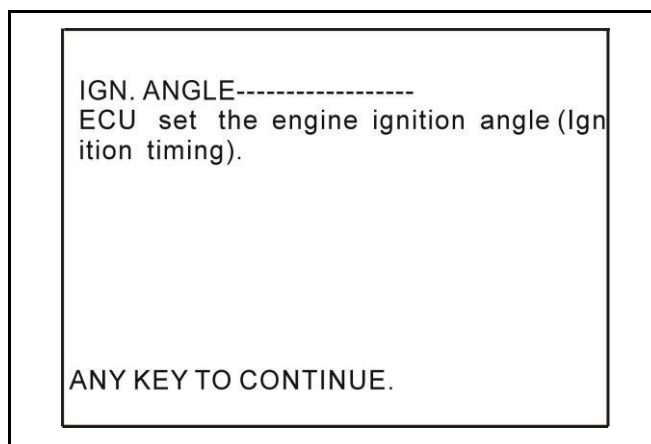

Press <F4> button to enter waveform page.
Press <EXIT> button to get back to Data Stream page.

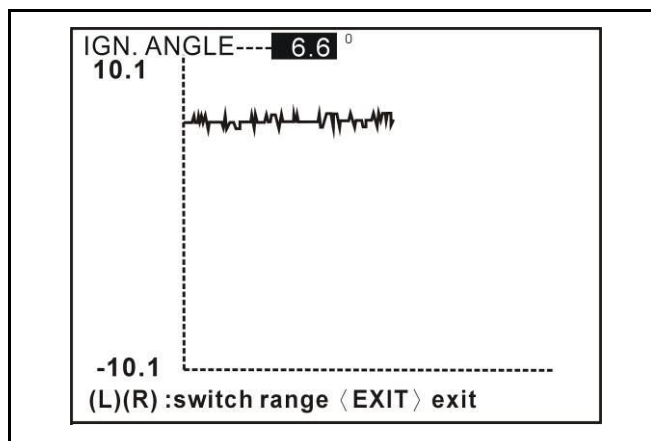

Press <UP> or <DOWN> button to choose IGN. CHARGE item.

(02-03) Data Stream ← * →

MAP-----	52 Kpa (40~60 Kpa)
INJECT TIME----	3.3 ms (1.5~2.5 ms)
IGN. ANGLE-----	5.6 ^o (8~18 ^o)
▶IGN. CHARGE--	3.36 ms (2.5~4.0ms)
RUN TIME----	5 Hr
FUEL PUMP-----	ON
TILTED SNSR---	0.58 V
BYPASS ADAPT--	-0.46 ^o (-50~120 ^o)
BYPASS LEARN--	104.6 ^o
BYPASS OPEN---	19.2 (0~240 ^o)

<UP> prev <DOWN> next <Enter> fixed <F4> waveform
 <EXIT> exit <LEFT> PgUp <RIGHT> PgDn <F1> Help

Press <F1> button to enter description page.
 Press any key to get back to Data Stream page.

IGN. CHARGE-----

ECU set the ignition transistor ON time interval (Ignition energy).

ANY KEY TO CONTINUE.

Press <F4> button to enter waveform page.
 Press <EXIT> button to get back to Data Stream page.

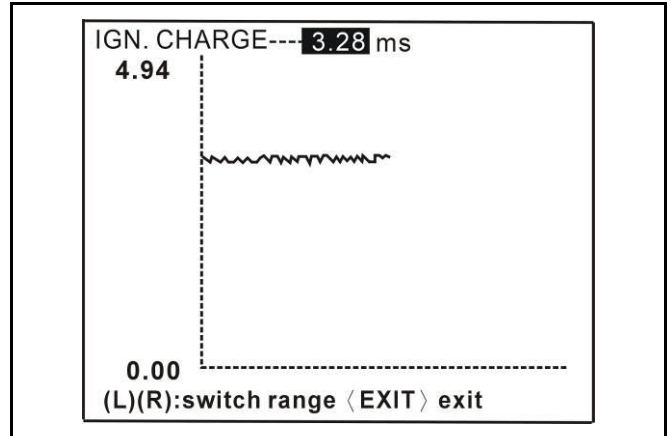

5. Fuel Injection System

SYM

Press <UP> or <DOWN> button to choose RUN TIME item.

```
(02-03) Data Stream  ←*
MAP----- 52Kpa (40~60 Kpa)
INJECT TIME---- 3.3ms (1.5~2.5 ms)
IGN. ANGLE----- 5.6° (8~18°)
IGN. CHARGE-- 3.36ms (2.5~4.0ms)
▶RUN TIME---- 5Hr
FUEL PUMP----- ON
TILTED SNSR--- 0.58V
BYPASS ADAPT-- -0.46° (-50~120°)
BYPASS LEARN-- 104.6°
BYPASS OPEN--- 19.2 (0~240°)
<UP> prev <DOWN> next <Enter> fixed <F4> waveform
<EXIT> exit <LEFT> PgUp <RIGHT> PgDn <F1> Help
```

Press <F1> button to enter description page.
Press any key to get back to Data Stream page.

```
RUN TIME-----
ECU interval timer to count key-on ad
d up time.

ANY KEY TO CONTINUE.
```

Press <UP> or <DOWN> button to choose FUEL PUMP item.

```
(02-03) Data Stream  ←*
MAP----- 52Kpa (40~60 Kpa)
INJECT TIME---- 3.3ms (1.5~2.5 ms)
IGN. ANGLE----- 5.6° (8~18°)
IGN. CHARGE-- 3.36ms (2.5~4.0ms)
RUN TIME---- 5Hr
▶FUEL PUMP----- ON
TILTED SNSR--- 0.58V
BYPASS ADAPT-- -0.46° (-50~120°)
BYPASS LEARN-- 104.6°
BYPASS OPEN--- 19.2 (0~240°)
<UP> prev <DOWN> next <Enter> fixed <F4> waveform
<EXIT> exit <LEFT> PgUp <RIGHT> PgDn <F1> Help
```

Press <F1> button to enter description page.
Press any key to get back to Data Stream page.

```
FUEL PUMP-----
==No description !! ==

ANY KEY TO CONTINUE.
```

Press <UP> or <DOWN> button to choose BYPASS ADAPT item.

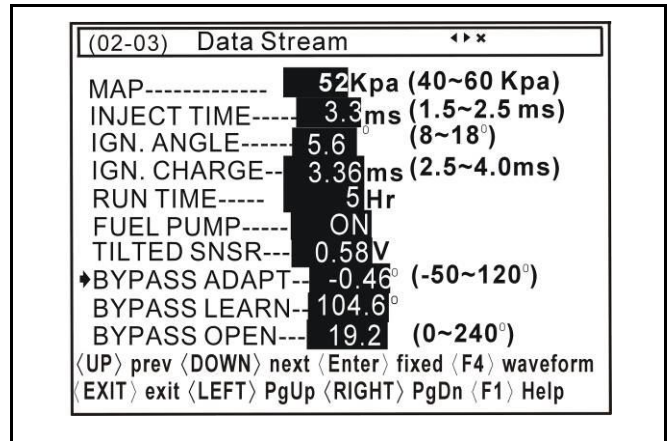

Press <F1> button to enter description page.
Press any key to get back to Data Stream page.

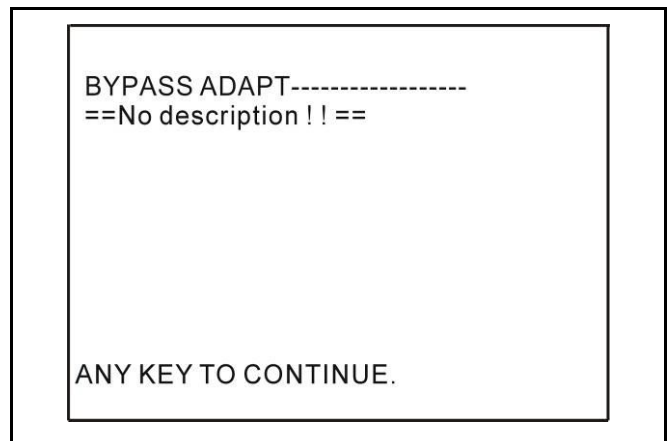

Press <F4> button to enter waveform page.
Press <EXIT> button to get back to Data Stream page.

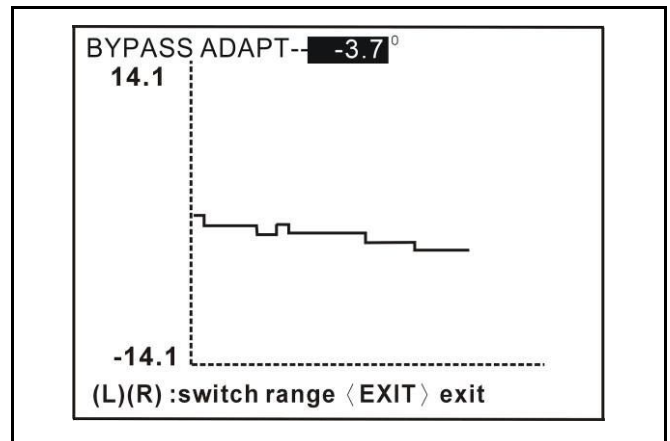

5. Fuel Injection System

SYM

Press <UP> or <DOWN> button to choose BYPASS LEARN item.

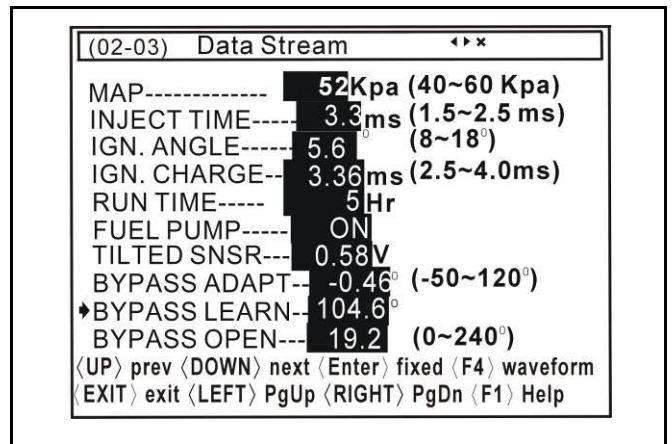

Press <F1> button to enter description page.
Press any key to get back to Data Stream page.

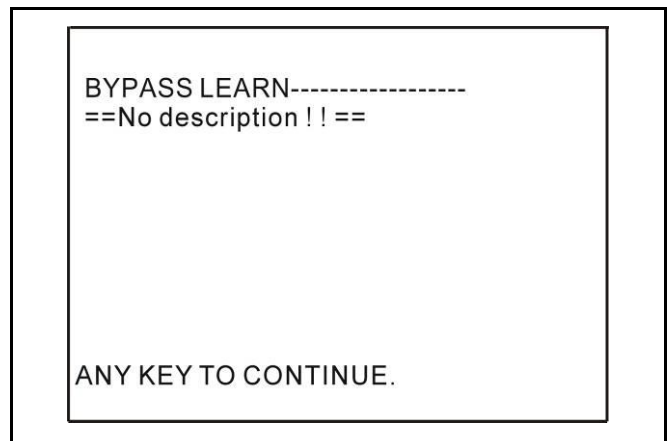

Press <F4> button to enter waveform page.
Press <EXIT> button to get back to Data Stream page.

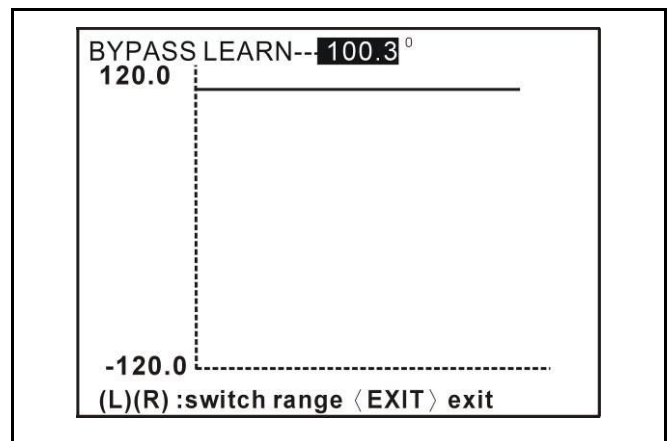

Press <UP> or <DOWN> button to choose BYPASS OPEN item.

```

(02-03) Data Stream  ←→*
MAP----- 52Kpa (40~60 Kpa)
INJECT TIME---- 3.3ms (1.5~2.5 ms)
IGN. ANGLE---- 5.6° (8~18°)
IGN. CHARGE-- 3.36ms (2.5~4.0ms)
RUN TIME---- 5Hr
FUEL PUMP---- ON
TILTED SNSR--- 0.58V
BYPASS ADAPT-- -0.46° (-50~120°)
BYPASS LEARN-- 104.6°
♦BYPASS OPEN--- 19.2 (0~240°)
<UP> prev <DOWN> next <Enter> fixed <F4> waveform
<EXIT> exit <LEFT> PgUp <RIGHT> PgDn <F1> Help
    
```

Press <F1> button to enter description page.
Press any key to get back to Data Stream page.

```

BYPASS OPEN-----
==No description !!==

ANY KEY TO CONTINUE.
    
```

Press <F4> button to enter waveform page.
Press <EXIT> button to get back to Data Stream page.

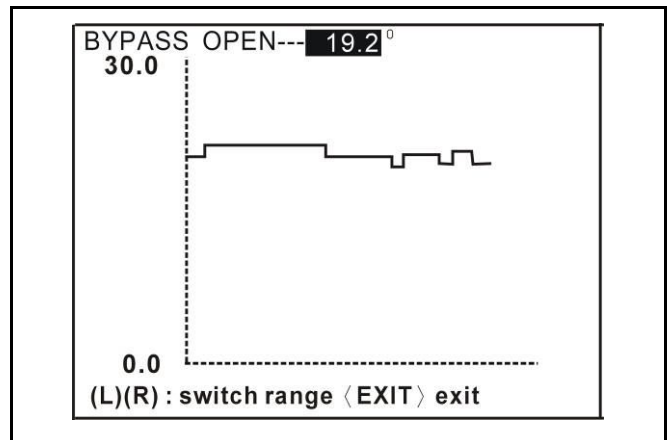

Press <RIGHT> button to get to next page to choose O2 SENSOR item.

(03-03) Data Stream ◀ ▶ *

▶ O2 SENSOR---- **0.82V** (0~1V)
O2 HEATER---- **ON** (ON)
O2 ADAPT---- **0.00** % (-32~32%)

<UP> prev <DOWN> next <Enter> fixed <F4> waveform
<EXIT> exit <LEFT> PgUp <RIGHT> PgDn <F1> Help

Press <F1> button to enter description page.
Press any key to get back to Data Stream page.

O2 SENSOR-----
==No description !! ==

ANY KEY TO CONTINUE.

Press <F4> button to enter waveform page.
Press <EXIT> button to get back to Data Stream page.

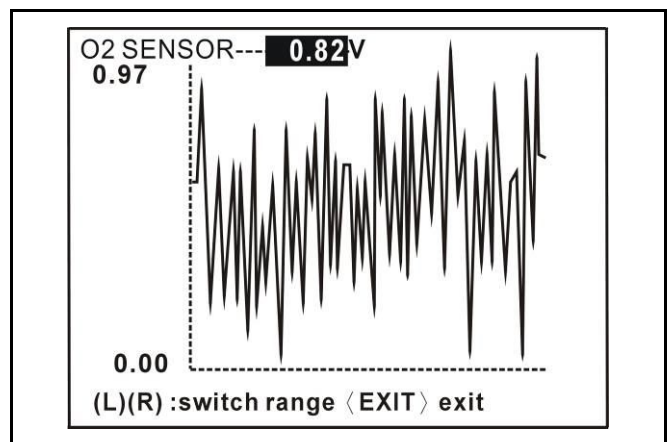

Press <UP> or <DOWN> button to choose O2 HEATER item.

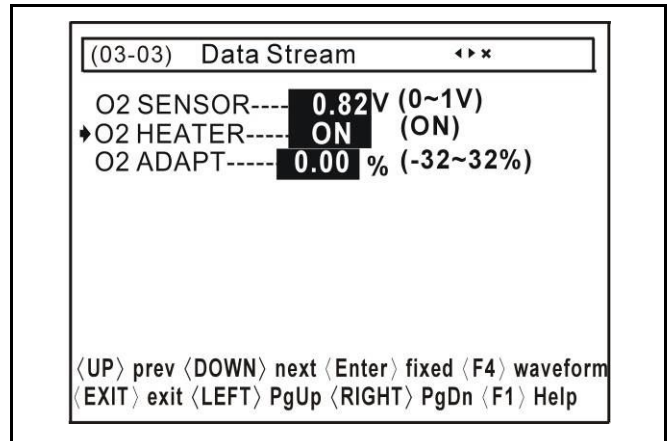

Press <F1> button to enter description page.
 Press any key to get back to Data Stream page.

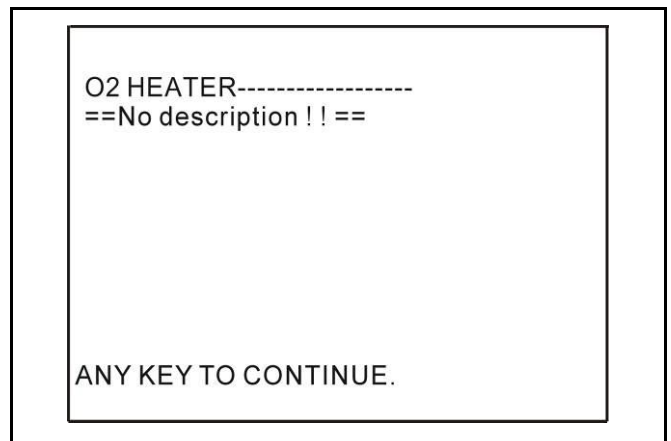

Press <UP> or <DOWN> button to choose O2 ADAPT item.

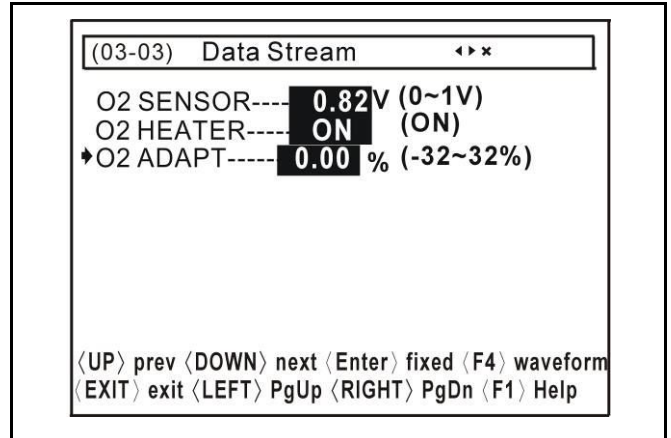

Press <F1> button to enter description page.
 Press any key to get back to Data Stream page.

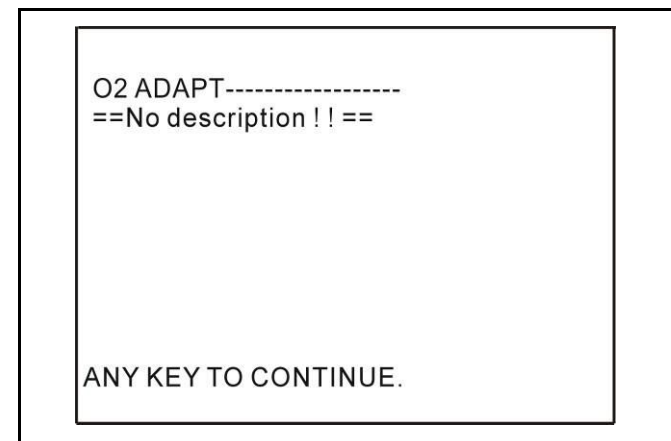

Read Trouble Code

Press <UP> or <DOWN> button to choose Trouble Code item.

Press <Enter> button read trouble code.

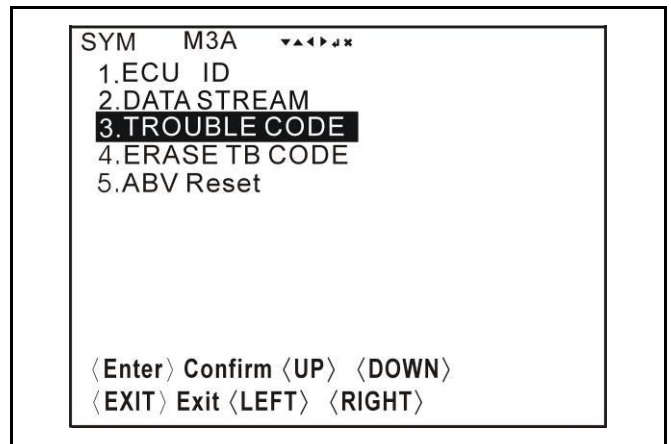

If there is no malfunction in the EFi system, "System is OK" will be shown.

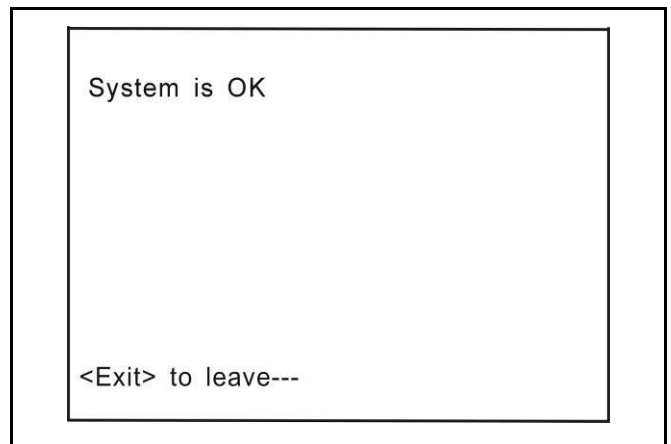

If there is malfunction happen to the EFi system, Trouble Code will be shown.

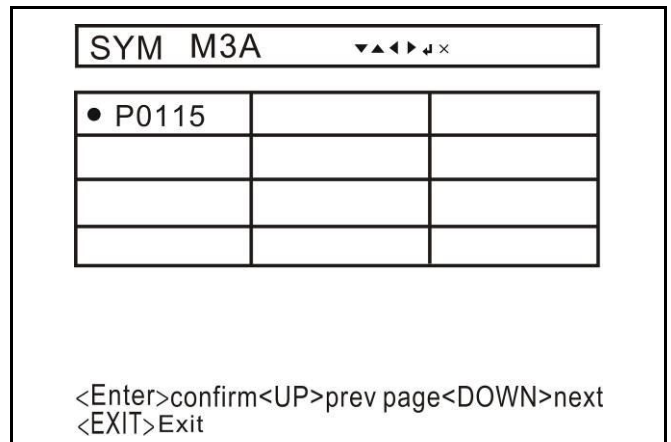

Press <Enter> button to enter Trouble Code and troubleshooting description page.

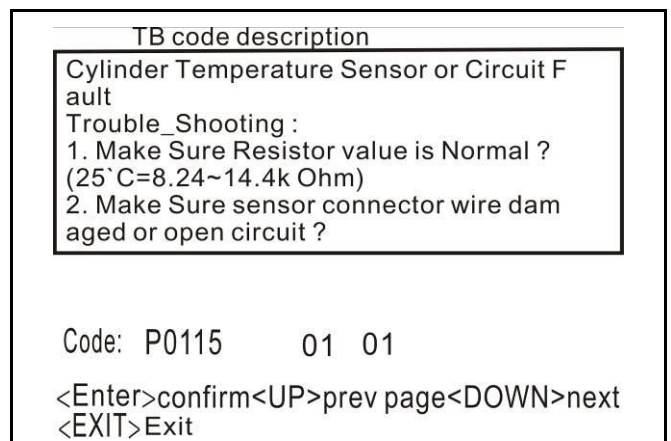

Erase Trouble Code

Press <UP> or <DOWN> button to choose Erase TB Code item.

Press <Enter> button erase Trouble Code.

```

SYM  M3A  ▼▲▶♦*
1.ECU ID
2.DATA STREAM
3.TROUBLE CODE
4.ERASE TB CODE
5.ABV Reset

```

```

<Enter> Confirm <UP> <DOWN>
<EXIT> Exit <LEFT> <RIGHT>

```

Key on but do not start the engine.
Press any key to erase Trouble Code.

```

POWER ON , ENG. STOP
TB CODE can erase
ANY KEY TO CONTINUE

```

Trouble Code is erased successfully.
Press <Enter> button to leave.

```

ERASE TB SUCC. !!
<Enter> leave...

```

Get back to function-options page.

```

SYM  M3A  ▼▲▶♦*
1.ECU ID
2.DATA STREAM
3.TROUBLE CODE
4.ERASE TB CODE
5.ABV Reset

```

```

<Enter> Confirm <UP> <DOWN>
<EXIT> Exit <LEFT> <RIGHT>

```

Reset ABV

Press <UP> or <DOWN> button to choose ABV reset item.

Press <Enter> button to reset ABV.

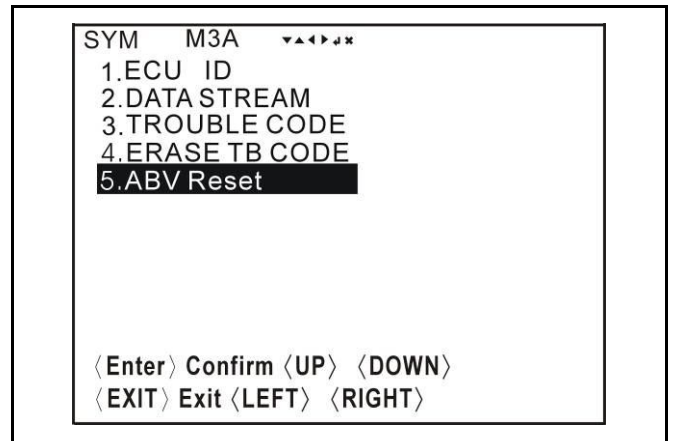

ABV reset is completed.
Press any key to continue.

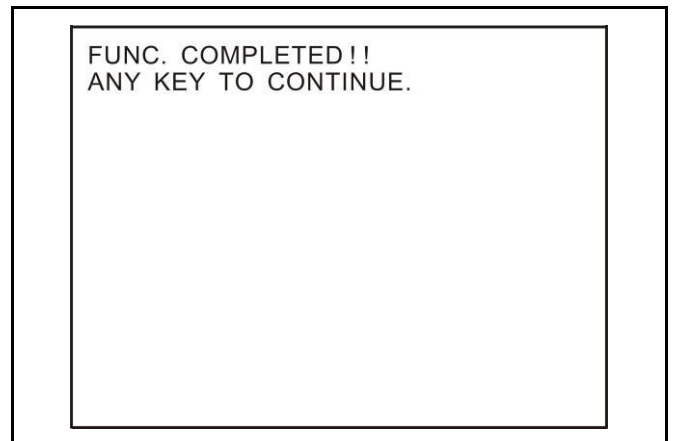

Get back to function-options page.

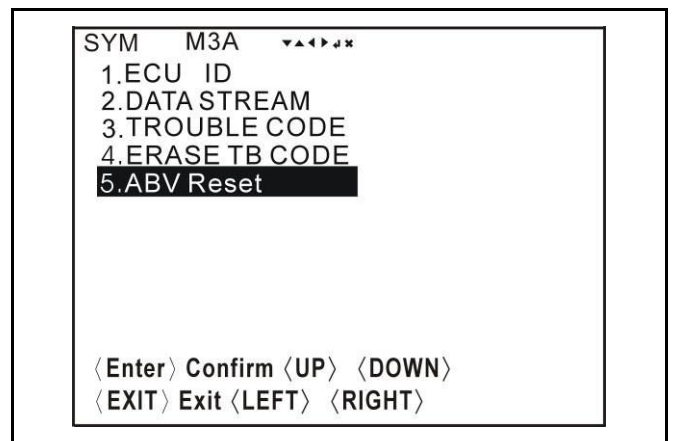

EFi Component Malfunction Check & Replacement Procedure

Item	Parts Name	Service schedule	Inspection Method	Adjustment & replacement procedure
1	Ignition coil	At least 20000km life-expectancy Check it every 3000km	Use diagnostic tool to check if the ignition coil has malfunction. Erase the DTC codes and replace with new coil and confirm again. If the DTC codes disappear, then the ignition coil is abnormal. Replace it with new one. If the DTC codes still exist, replace the ECU for confirm. If the DTC codes disappear, then the ECU is abnormal. Replace it with new one Before the ignition coil is verified for malfunction, check the coil resistance and connector wire for short-circuit.	If the ignition coil has to be changed, erase the DTC codes with the diagnostic tool. Turn off ignition switch, and replace the coil with new one. Turn on ignition switch and make sure the DTC codes disappear.
2	Air by-pass valve	At least 20000km life-expectancy Check it every 3000km	Check if the by-pass valve DTC code appears on the diagnostic. Erase the DTC codes and replace with new one & confirm again. If the DTC codes disappear, then the by-pass valve is abnormal. Replace it with new one. If the DTC codes still exist, check if the wire connector and by-pass valve resistance are normal. If the DTC codes still exist, replace the ECU for confirmation. If the DTC codes disappear, then the ECU is abnormal. Replace it with new one.	If the by-pass valve has to be changed, erase the DTC codes with the diagnostic tool first. Turn off the ignition switch, and then replace the valve with new one. Turn on ignition switch and make sure the DTC codes disappear. Check idle speed CO value and adjust if necessary.
3	fuel pump and fuel regulating valve	At least 20000km life-expectancy Check it every 6000km	Connect a pressure gauge between the regulator and fuel injector. Make sure fuel pressure is within 2.5bar. The pressure should reach 2.5 bars within 3 seconds after turning on ignition switch. If the fuel pressure is out of the range, check if the fuel pipe is leaking. And check if the fuel pump voltage is over 12V? Replace the fuel-regulating valve and confirm again.	The oil seal has to be replaced along with replacement of the fuel-regulating valve. Oil seal has to be installed into the outer cover before assembling.
4	Engine temperature sensor	At least 20000km life-expectancy Check it every 3000km.	Is there any DTC code on the Data Scan diagnostic? Engine temperature has to reach to environmental temperature after engine stopped for a while. Erase the DTC codes and replace with new one and confirm again. If the DTC codes disappear, then the sensor is abnormal. Replace it with new one. If the DTC codes still exist, check if wire connector and sensor's resistance are in normal range	If the sensor has to be changed, erase the DTC codes with the diagnostic tool. Turn off ignition switch, and remove connector. Remove the sensor with tools. Engine temp. Sensor tighten torque is 0.74~0.88kg-m. Connect the coupler, and the diagnostic tool. Then, turn on ignition switch. Check if the DTC codes disappear. The value of stopped engine temperature should approximate the environmental temperature.

Item	Parts Name	Service schedule	Inspection Method	Adjustment & replacement procedure
5	Intake temperature/pressure sensor	At least 20000km life-expectancy Check every 3000km	Connect the diagnostic tool for inspection. The engine intake temperature and pressure should approximate environmental temperature and atmosphere pressure. (Execute this task after engine is stopped for a while) If the DTC codes of intake temperature or pressure shown on the diagnostic tool, replace the pressure sensor with new one. Check if the DTC codes are disappearing. If not, check the connector wires for short-circuit. Replace the connector if necessary. If the DTC codes still exist, replace the ECU. But if the DTC codes disappear, install the original pressure sensor and check it again. If the original sensor doesn't trigger the DTC error code, replace the ECU with new one.	Replacement procedure for T-MAP (intake temperature/pressure sensor) Turn off the ignition switch. Disconnect the connector of intake temperature/pressure sensor. Replace the sensor with new one. Connect the connector with diagnostic tool. Turn on the ignition switch, and check if the intake temperature/ pressure readings close to environmental temperature and atmosphere pressure. Erase the DTC codes, and make sure the problem is solved.
6	Throttle body	At least 20000km life-expectancy Check every 3000km	Please refer to idle speed adjustment section for the idle speed CO adjustment. Connect the diagnostic tool and check if the throttle position DTC code appears. If the code appears, replace the throttle body to make sure the code can be erased. If the code disappears, replace the throttle body. If the code still exists, replace the ECU with new one.	The throttle body replacement procedure: Install a new throttle body Make sure there is no leaking. Connect the diagnostic tool and read the carbon-accumulated time. Reset the time with the diagnostic tool. Reset the throttle position data with the diagnostic tool. Throttle valve WOT set up. Turn off ignition switch, and WOT the throttle valve and hold. Turn on the ignition switch and hold WOT position for 2 seconds. Then release the throttle valve. Please refer to the idle speed adjustment section for the idle speed CO if necessary.
7	Fuel injector	At least 20000km life-expectancy Check every 3000km	Check if the fuel injector DTC code appears. If the code appears, replace a new fuel injector for confirmation. If the code can be erased, then, replace the fuel injector. If the code still is there after changing a new injector, check if connector wire is short. If the code still exists, replace the ECU with new one. If the code can be erased after changing the ECU, this ECU has to be replaced.	Confirmation or replacement procedure for the fuel injector: Erase the DTC code with the Data Scan. Turn off ignition switch and disconnect the fuel injector coupler. Connect to a new fuel injector. Connect the diagnostic tool, and turn on the ignition switch. Make sure the DTC code had been cleared. Please refer to idle speed adjustment section for idle speed CO value confirmation. (Firstly, make sure if the fuel injector DTC code had been clear, and then install a new fuel injector.)

Item	Parts Name	Service schedule	Inspection Method	Adjustment & replacement procedure
8	ECU	At least 20000km life-expectancy Check every 3000km	Connect the diagnostic tool. Record the ECU service time.	ECU replacement procedure: Connect the Diagnostic tool onto the original ECU. Record the ECU service time. Turn off the ignition switch. Replace the ECU with new one. Re-set the ECU service time. Clean the carbon deposition around the throttle body. Please refer to idle speed adjustment section for idle speed CO value confirmation.
9	Idle speed CO Adjustment	Check for new motorcycle and every 3000km.	Warm up the motorcycle by running it in 50km/hr for 5 minutes. Connect the diagnostic tool. Record the idle speed CO value, and engine rpm In O2 sensor closed-loop system, the CO value should be kept in normal range. If the CO value goes wild, please check the O2 sensor, engine, injector, and the fuel system for malfunction.	Warm up the motorcycle by running it in 50km/hr for 5 minutes. Connect the Diagnostic tool. Record the idle speed CO value, rpm. Use the Data Scan to adjust the idle speed CO value to be 0.5%~2.0%. Record the idle speed CO value, rpm and CO variant value. (The engine temperature has to be in 115°C~140°C, and intake temperature to be in 25°C~40°C as adjusting.) Perform ECU learning

NOTE:

Mechanism Diagram - Front Disk Brake.....11-1	Brake Fluid Replacement / Air Bleed.....11-6
Mechanism Diagram - Rear Disk Brake.....11-2	Front Brake Caliper.....11-7
Precautions in Operation.....11-3	Rear Brake Caliper.....11-8
Troubleshooting.....11-4	Brake Disk.....11-9
Disk Brake System Inspection.....11-5	Brake Master Cylinder.....11-10

Mechanism diagram – front disk brake

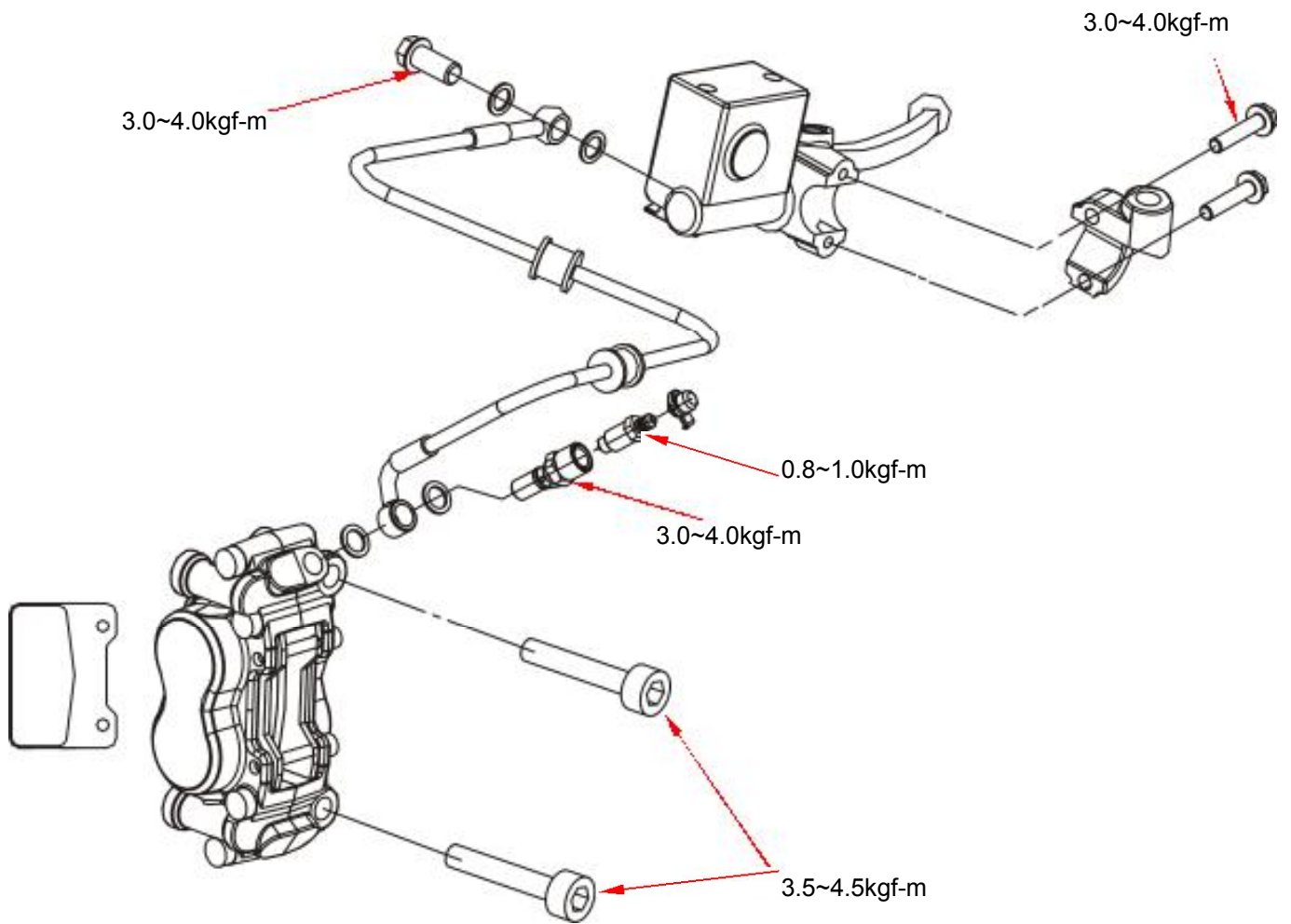

Mechanism diagram – rear disk brake

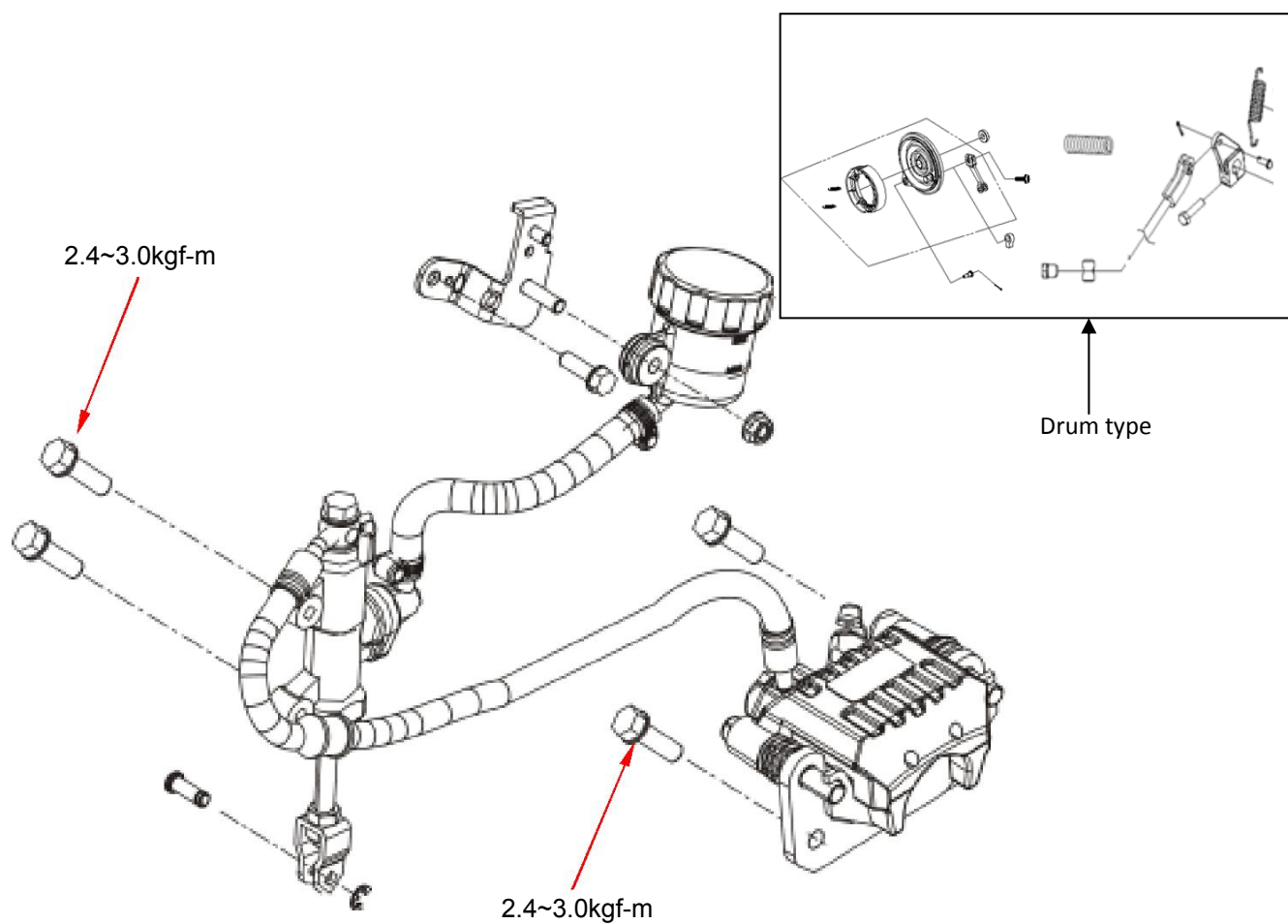
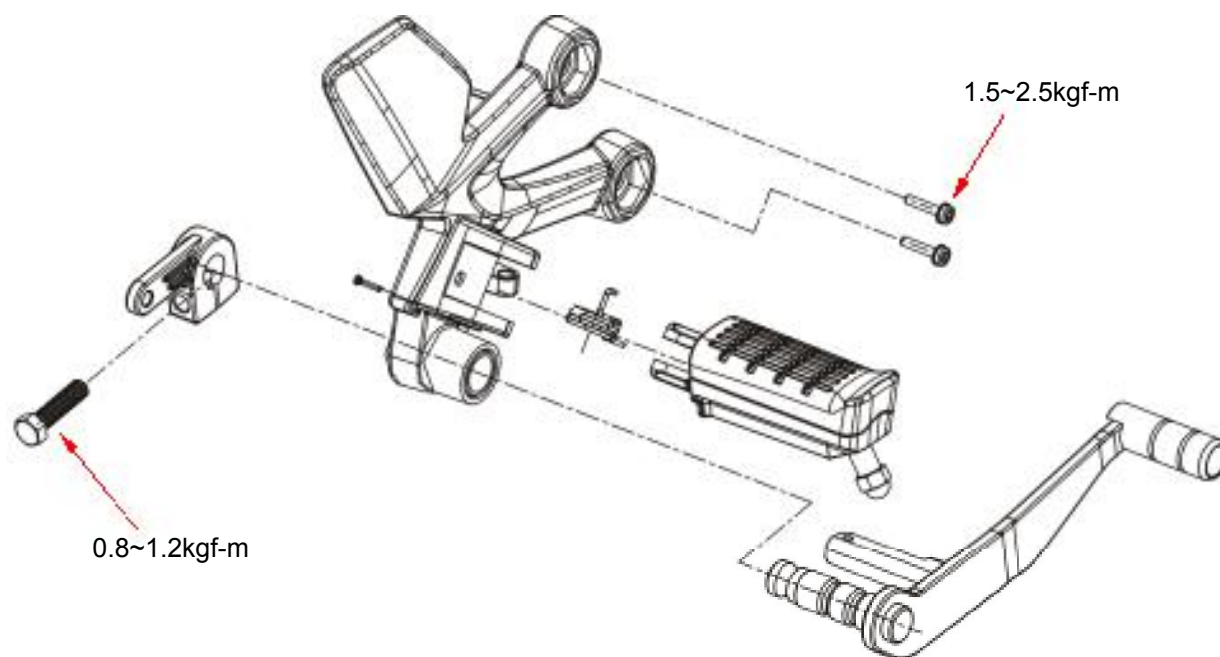

CBS System structure

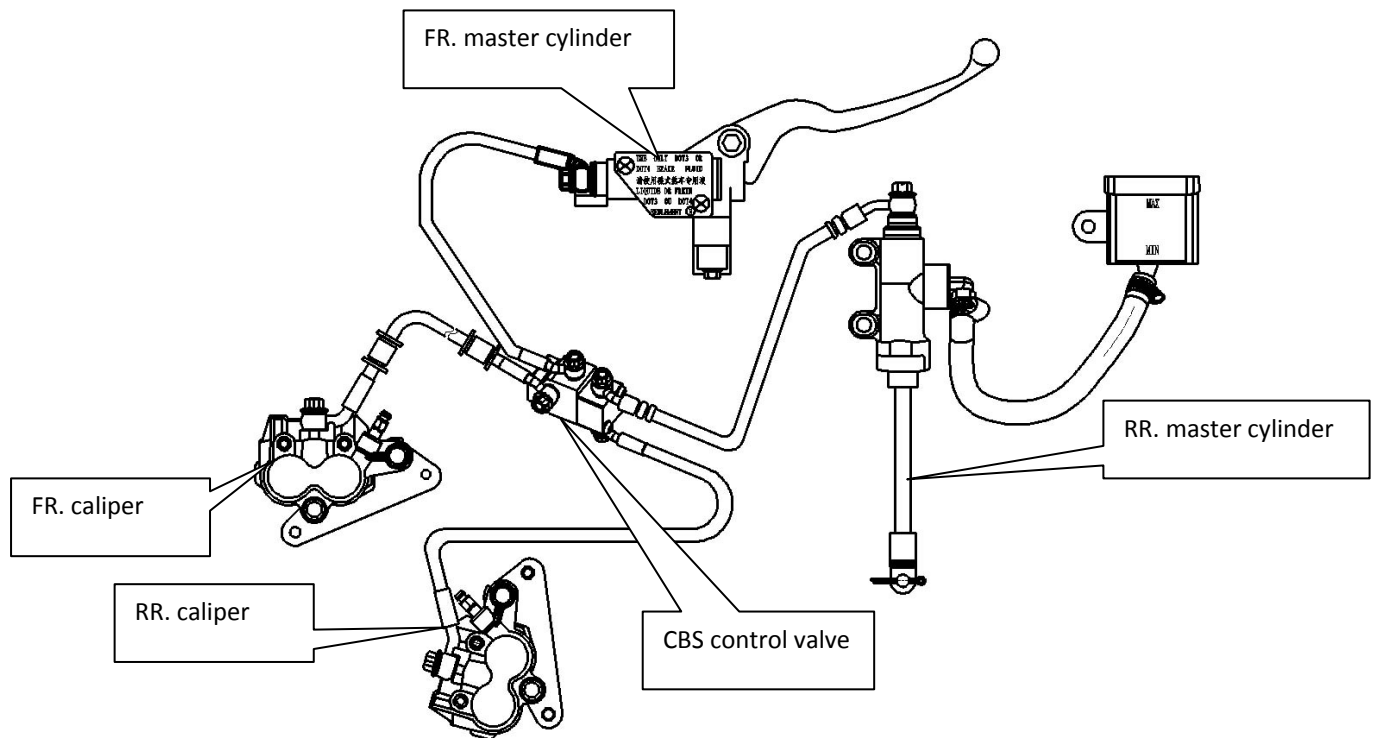

The front brake handle controls the front brake calipers through the front brake oil pipe, which is an independent front brake system; the rear brake master pump passes through the rear brake oil pipe and passes through the CBS control valve, producing two separate forces, one of which controls the rear brake calipers, the other drives the piston on the proportional valve, and controls the front brake calipers through the oil pipe. There is a delay piston spring on the proportional valve. When the operating force applied on the rear brake master pump is greater than or equal to the resultant force of the delay piston spring, the piston of the proportional valve starts to work and the linkage front brake caliper starts to brake. This is the working principle of the CBS system. The operating mode and braking type of the general rear brake can be decided by the production enterprise according to its own actual situation.

In the CBS system, the key component is actually a proportional valve, which is equivalent to the brain in the CBS system and acts as a delay valve.

When the foot brake pedal, the hydraulic pressure generated by the brake pedal is first transmitted to the rear brake caliper through the proportional valve to control the rear wheel braking. When the hydraulic pressure generated by the brake pedal gradually rises to a predetermined value, the proportional valve transmits the pressure to the front brake caliper at the same time. So that the front wheel brake of the vehicle also starts to work, and then the motorcycle decelerates.

When motorcycle uses CBS system, it can reduce the phenomenon of "brake after single operation, brake after lock" and distribute the brake force to front and rear wheel brake reasonably through the distribution of CBS distributor, so as to avoid the phenomenon of holding brake caused by excessive brake force of single brake and brake.

Precautions in operation

Caution

Inhaling asbestos may cause disorders of respiration system or cancer, therefore, never use compressed air or dry brush to clean brake system. Use vacuum cleaner or other authorized tool instead.

The brake caliper can be removed without removing the hydraulic system.

After the hydraulic system is removed, or the brake system is felt to be too soft, bleed the hydraulic system.

While refilling brake fluid, care should be taken not to let the foreign material entering the brake system.

Do not spill brake fluid on the painted surfaces, plastic, or rubber parts to avoid damage. Check the operation of the brake system before riding.

Specification

measurement: mm

Item	Standard	Service limit
Front brake disk thickness	5.00	4.50
Rear brake disk thickness	4.00	3.00
Front brake disk outer diameter	288.00	—
Rear brake disk outer diameter	222.00	—
Brake disk eccentricity	0.1	0.30
Bake pad thickness	—	Mark on brake pad

Torque value

Brake hose bolt	3.0~4.0kgf-m
Front brake caliper bolt	3.5~4.5kgf-m
Brake disk bolt	3.7~4.3kgf-m
Air bleed valve	0.8~1.0kgf-m
Front wheel axle nut	6.0~8.0kgf-m
Rear wheel axle nut	10.0~12.0kgf-m

Special tool

Inner bearing puller SYM-6204020

Troubleshooting

Disk brake

Soft brake lever

1. Air inside the hydraulic system
2. Hydraulic system leakage
3. Worn master cylinder piston
4. Poor brake caliper
5. Worn brake pad
6. Low brake fluid
7. Blocked brake hose
8. Warped / bent brake disk
9. Bent brake lever

Hard brake lever operation

1. Blocked brake system
2. Poor brake caliper
3. Blocked brake hose
4. Seized / worn master cylinder piston
5. Bent brake lever

Uneven brake

1. Dirty brake pad / disk
2. Poor wheel alignment
3. Blocked brake hose
4. Warped / bent brake disk
5. Blocked brake hose / joint

Tight brake

1. Dirty brake pad / disk
2. Unbalanced brake disk / wheel
3. Warped / bent brake disk

Brake noise

1. Dirty brake pad / disk
2. Deformed brake disk
3. Poor brake caliper installation
4. Imbalanced brake disk / wheel

Disk brake system inspection

Inspection

Visually examine for leakage or damage. Inspect the brake hose joint for looseness. Turn the handle bar to right and left; press the cushion to see if there is any interference with the brake system.

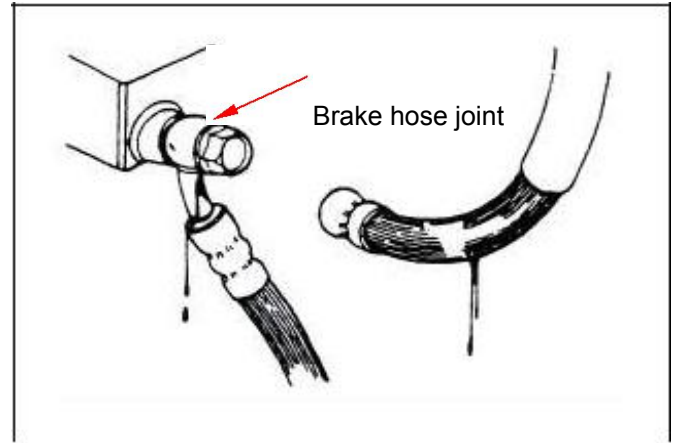

Check if the brake pads worn. Replace the brake pads if either pad is worn to the bottom of wear limit groove.

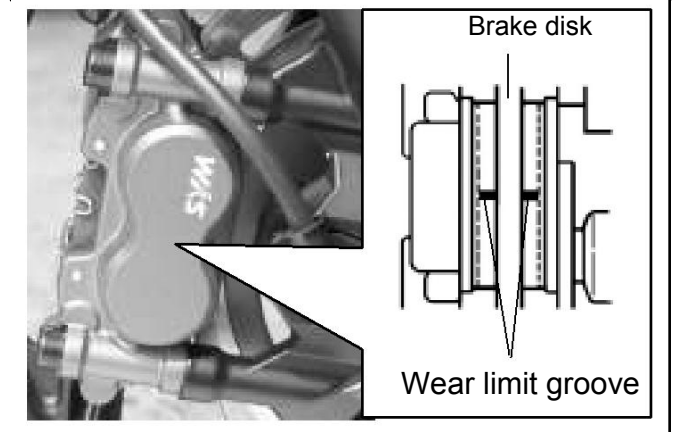

Park the vehicle on the level ground. Check the brake fluid level.

Recommended Brake Fluid: WELL RUN BRAKE OIL (DOT 3).

Caution

When the vehicle is inclined or just stopped, the brake fluid level could not be accurate.
Do not mix different types of brake fluid which are not compatible with each other.
Use the same brand brake fluid to ensure the brake efficiency.

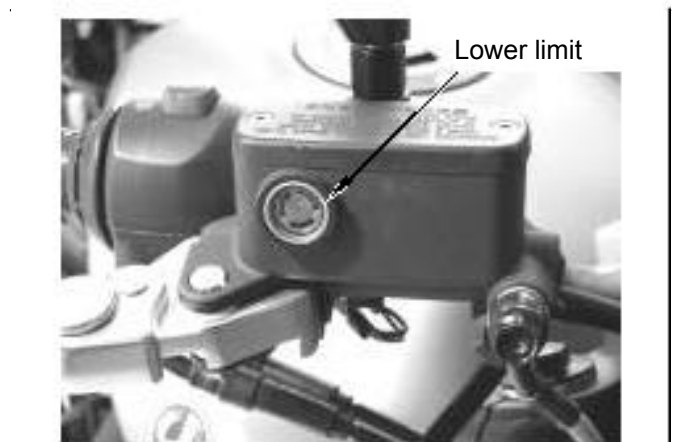

Adding brake fluid

Turn the handlebar to make the reservoir level before opening the reservoir cap. Cover the painted, plastic or rubber surface with a rag before performing brake system maintenance.

Caution

Do not fill brake fluid over upper limit.

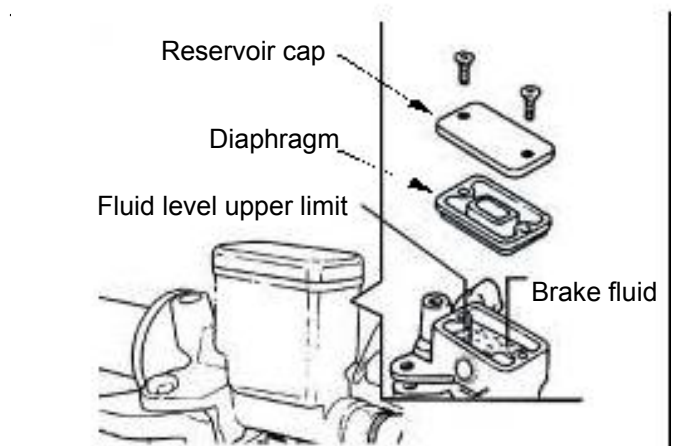

Remove the reservoir cap and diaphragm.
Fill the clean brake fluid.
Clean the dirty brake disk.

⚠ Caution

Contaminated brake disk or pad decreases braking performance.
Foreign material will clog brake system and lead to decline or malfunction of braking capability.

Brake fluid replacement / air bleed Connect a drain hose to air-bleed valve. Open the air-bleed valve. Pump the brake lever until the old brake fluid is entirely drained out. Close the air-bleed valve and add specified brake fluid into the brake fluid reservoir.

⚠ Caution

Reuse of old brake fluid will affect brake efficiency.

Connect a drain hose to the air-bleed valve, and put the other end into a container.

Open the air-bleed valve around 1/4 turns, and at the same time pump the brake lever until there is no air bubble in the drain hose and also feeling resistance on the brake lever.

Close the air-bleed valve when the brake system fluid filling procedure is finished. Pump the brake lever to check whether air bubble is in brake system or not.

If brake is still soft, please bleed the system as described below:

1. Tightly hold the brake lever and open the drain valve around 1/4 turns, and then close the valve.

⚠ Caution

Do not release the brake lever before the air-bleed valve is closed.
When bleeding air, frequently check fluid level to avoid air entering the brake system.

2. Release the brake lever slowly.
3. Repeat step 1 and 2 until there is no air bubble at the end of the hose. Tighten air-bleed valve.
4. Confirm the brake fluid level, add fluid if necessary.
5. Cover the reservoir cap.

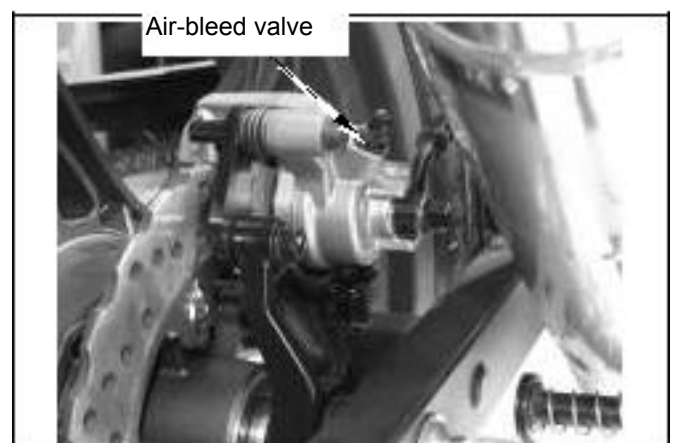
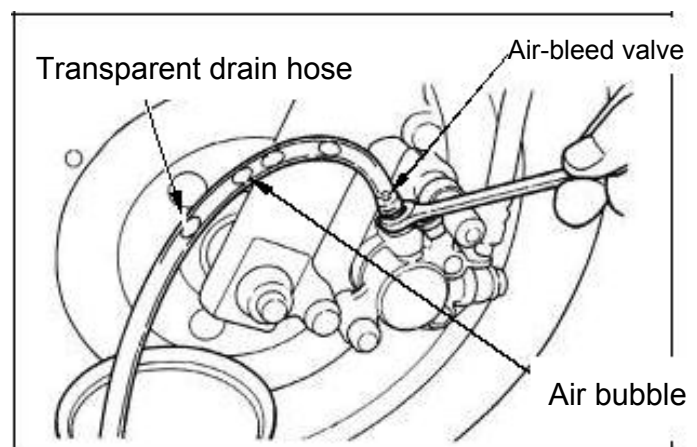
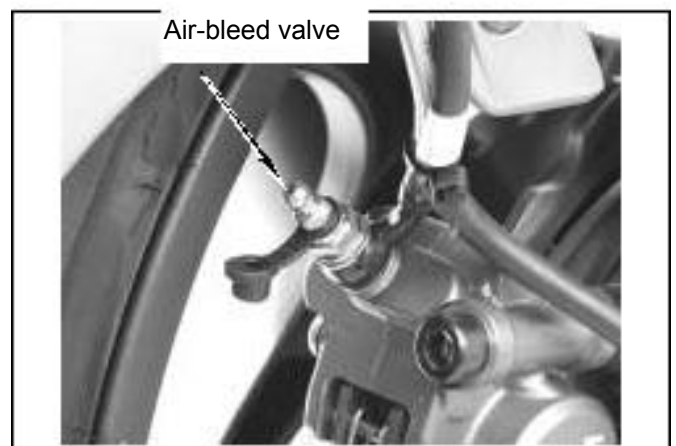
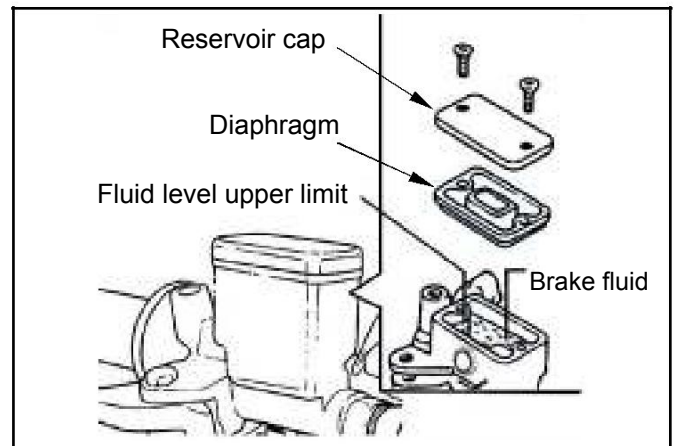

Front brake caliper

Removal

Place a container under the brake caliper, and loosen the brake hose bolt, drain brake fluid.

Caution

Do not spill brake fluid on painted surfaces.

Remove caliper bolts, (bolt×2) remove the caliper.

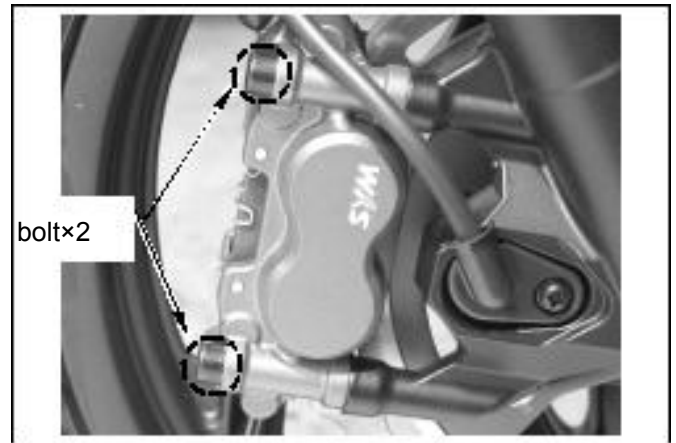

Check the brake pad wear condition, replace with new brake pad if wear limit is reached. Installation

Install the caliper and tighten the bolts.

Torque value: 3.5~4.5kgf-m



Brake pad replacement

Remove pin clips.

Remove pad pins and spring.



Remove brake pads.

Install new brake pads, pad pins, and spring.

Install pin clip.

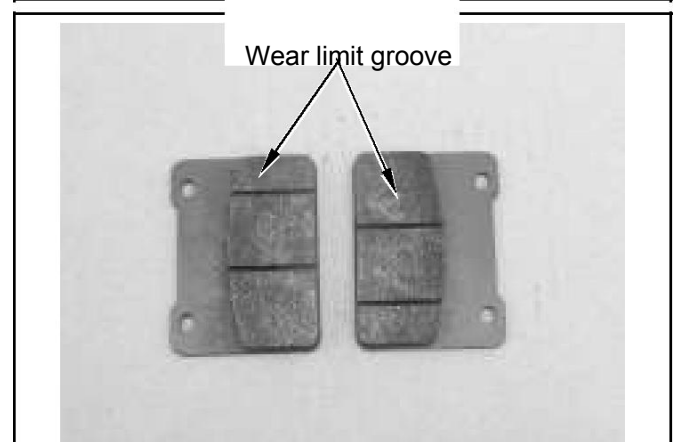

Rear brake caliper

Removal

Place a container under the brake caliper, and loosen the brake hose bolt, drain brake fluid.

⚠ Caution

Do not spill brake fluid on painted surfaces.

Remove caliper bolts, (bolt×2) remove the caliper.

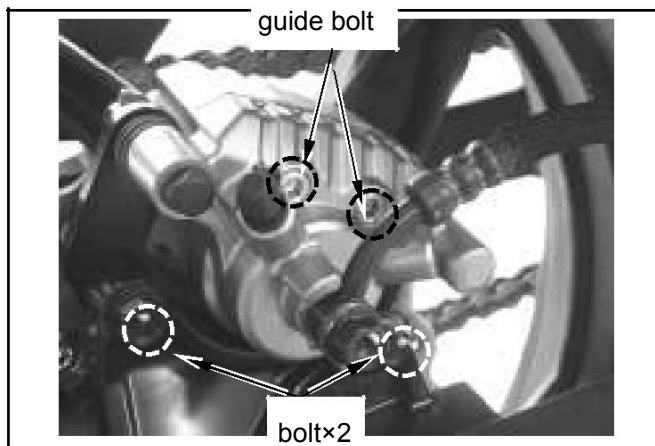

Check the brake pad wear condition, replace with new brake pad if wear limit is reached. Installation

Install the caliper and tighten the bolts.

Torque value: 3.1~3.5kgf-m

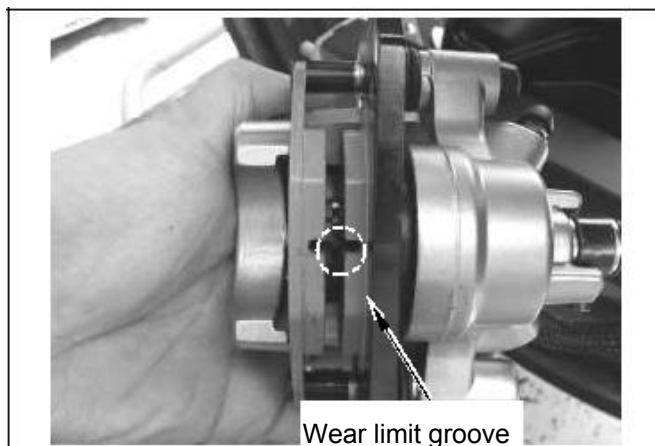

Brake pad replacement

Remove guide bolts.

Remove brake pads.

Remove pad support.

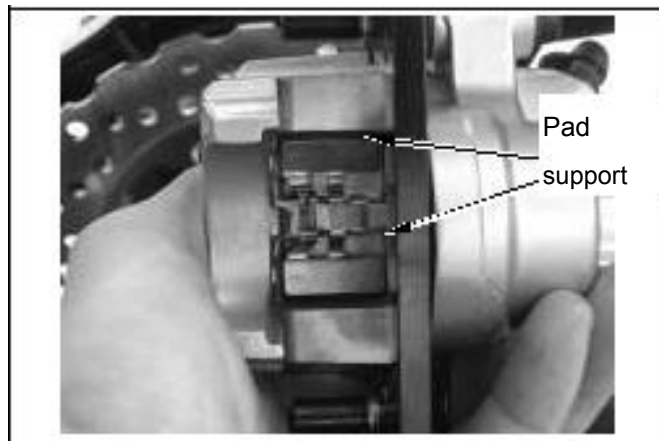

Install pad support.

Install new brake pads.

Install guide bolts.

Install brake caliper, tighten caliper bolts.

Torque value: 1.5~2.0kgf-m

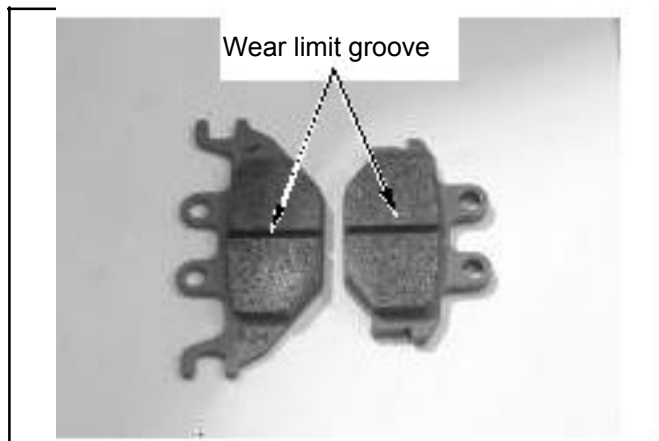

Brake disk

Inspection

Visually check if the brake disk worn or damaged.

Measure the thickness of the disk at several places. Replace the disk if it has exceeded the service limit.

Remove the brake disk from wheel.
Check if the disk for deformed or bent.

Caution

The dirty brake pad or disk will reduce the brake performance.

Brake pad includes the asbestos ingredient. Do not use compressed air to clean the brake system. The operator should put on gauze mask and glove, use vacuum cleaner to clean it.

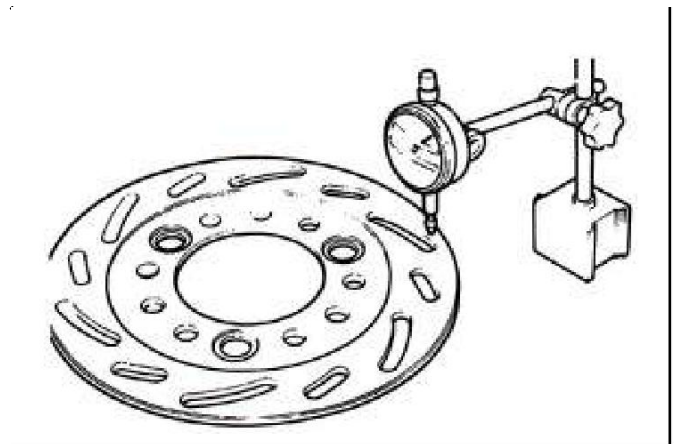
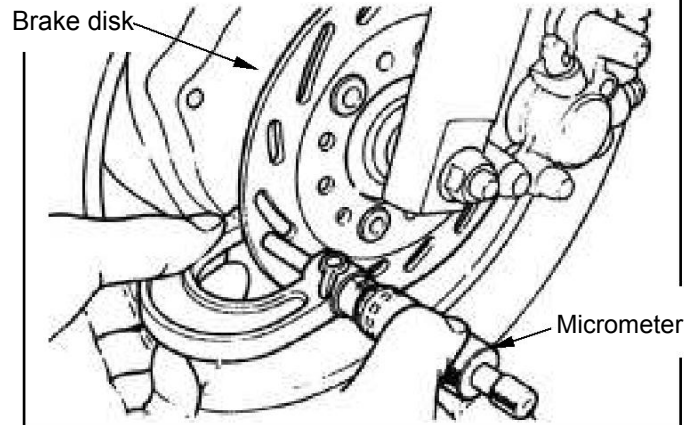

Front brake disk service limit: 4.5 mm



brake disk service limit: 3.0 mm

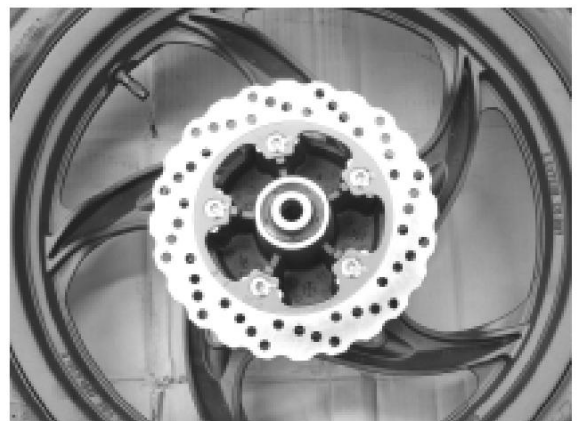

Brake master cylinder

Removal

Caution

Do not let foreign materials entering the cylinder.

- Remove back mirror.
- Disconnect brake light coupler.
- Drain brake fluid.
- Remove the brake lever from brake master cylinder.
- Remove brake hose.
- Remove brake master cylinder from handlebar. (bolt×2).
- Clean the master cylinder with recommended brake fluid.

Installation

- Install brake master cylinder on handle bar, tighten bolts. (bolt×2).
- Torque value: 0.8~1.2kgf-m
- Install brake lever, connect brake light coupler.

- Apply 2 new seal washers, install brake hose.
- Tighten the brake hose bolt to the specified torque value.
- Torque value: 3.0~4.0kgf-m
- Make sure the hose is installed correctly.

Caution

Improper routing may damage the hose and wire.
Twisted brake hose and wire may reduce brake performance.

Add specified brake fluid and bleed the system.

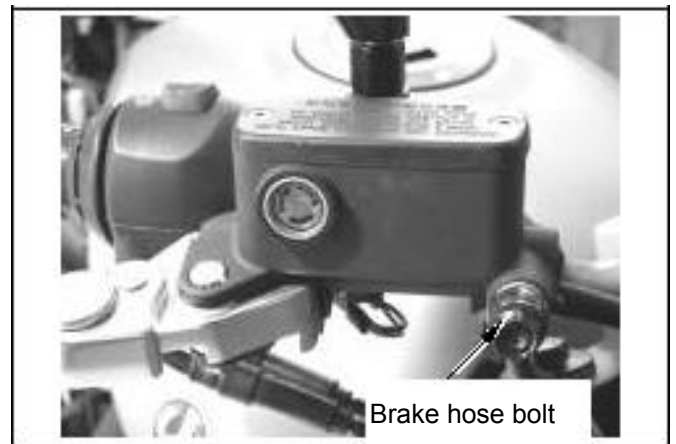
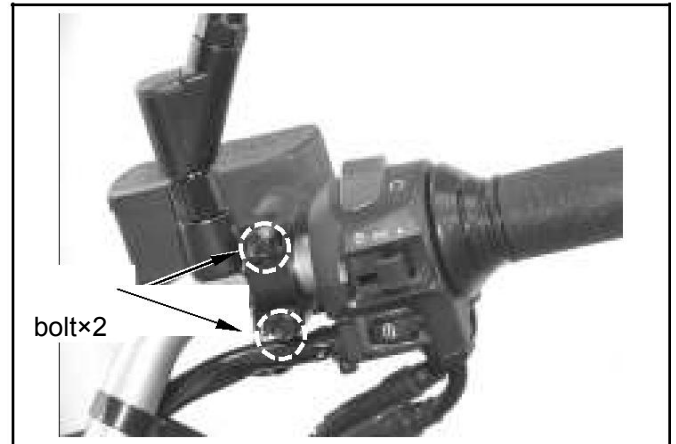

Brake Drum

Removal

Use a vacuum cleaner and other suitable tools to clean the brake parts to minimize the hazard caused by the asbestos dust.

⚠ Caution

- Inhaling asbestos dust may cause respiration system disorder or even cancer. Never use compressed air or dry brush to clean the brake system.
- Grease on brake shoe will reduce braking efficiency.

Remove the wheel rim and brake drum.

Inspection

Check the brake drum for wear or damage. Replace the wheel hub if necessary.

Measure the brake drum inner diameter at several points and record the largest value.

Service limit : 130.5mm

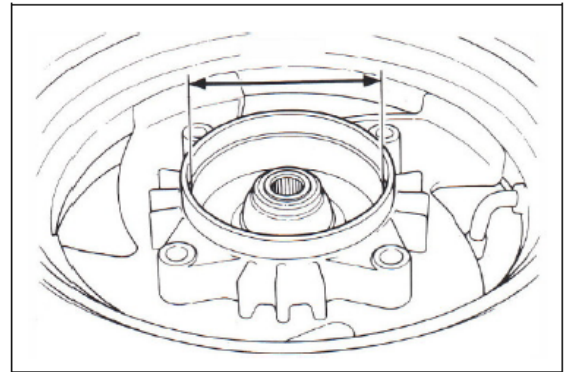
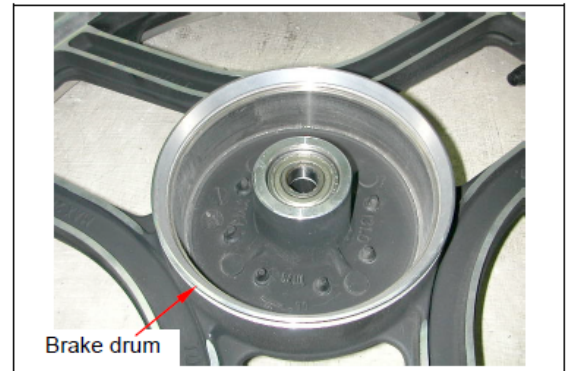

⚠ Caution

Remove the rust by using #120 sand papers.

- An inside micrometer must be used when measuring the brake drum inner diameter.

Brake Shoe

Inspection

Measure the brake shoe thickness at three points (both ends and center).

If the thickness is less than specified, or if it is contaminated by oil or grease, replace as a set.

Service limit : 2.0 mm

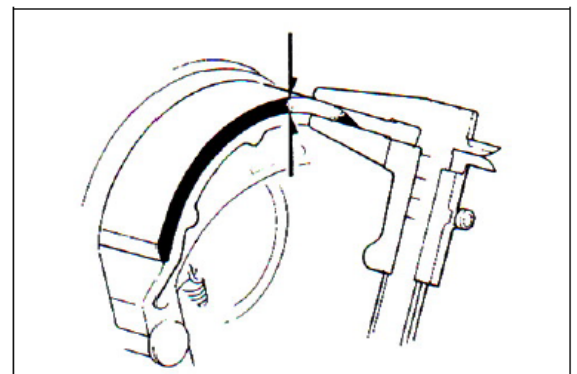
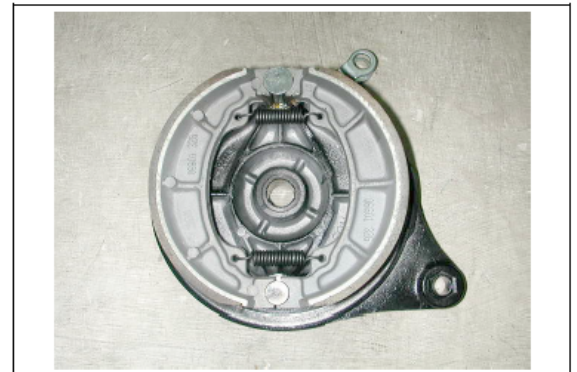

Removal

⚠ Caution

- Brake linings must be replaced as a set.

Remove the brake shoes from the brake panel by pulling out the brake shoes.

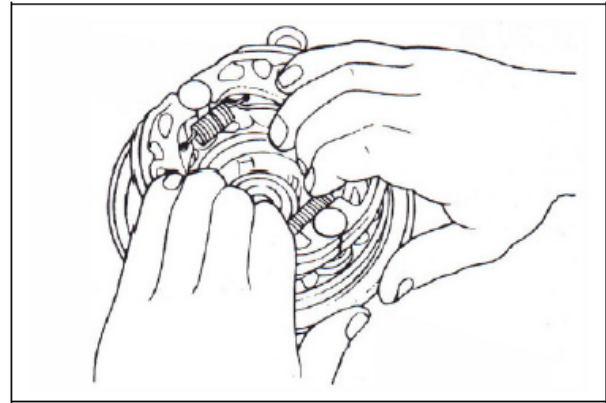

Installation

Apply a thin coat of grease to the brake cam and the position pin.

Hook the brake shoe spring onto the brake cam.

Pull out the brake shoes and install them onto the brake panel.

Wipe off the excessive grease from the brake cam installation.

Slightly grind the brake shoe surface with sand-paper to clean the surface.

⚠ Caution

- Braking efficiency will be reduced if brake shoe is contaminated by oil or grease.

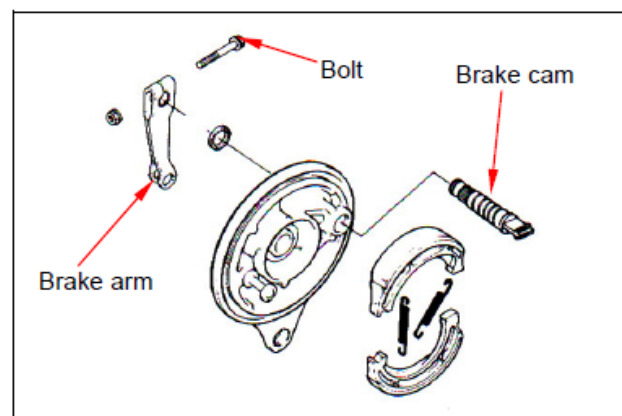
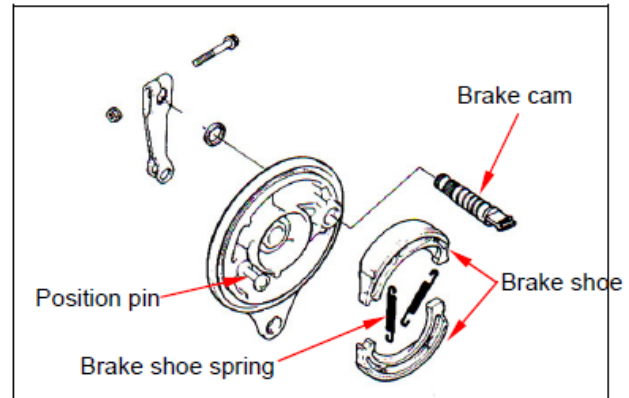

Brake Panel

Removal

Remove the brake arm bolt, brake arm, brake return spring and brake cam as well as the oil seal from the brake panel.

Installation

Apply a thin coat of grease between the oil seals on the brake cam.

Install the brake cam.

Align the mark on the brake arm with the inner gear of the brake cam.

Tighten the bolts and nuts to specified torque.

Torque value : 0.8~1.2kgf-m

CBS Brake System

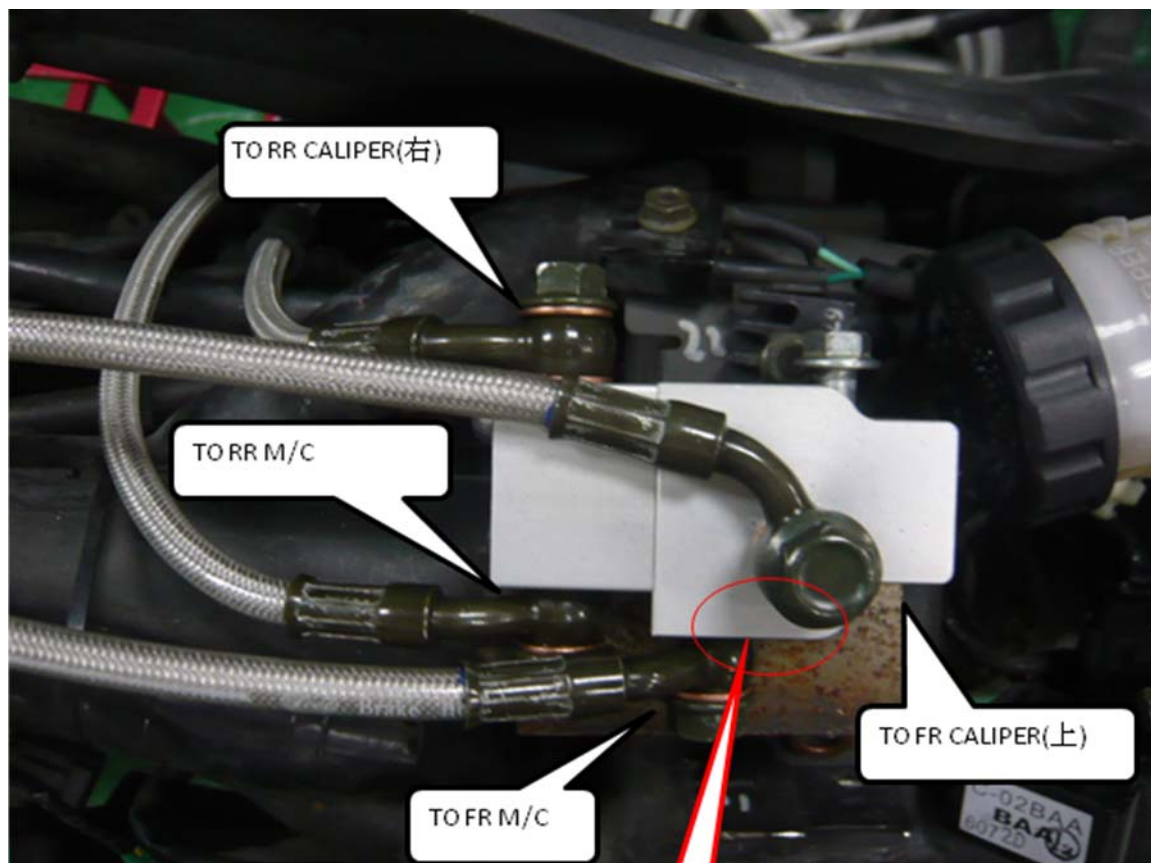

空氣累積處

Mechanism Diagram.....12-1	Front Wheel.....12-6
Precautions in Operation.....12-2	Front Fork.....12-9
Troubleshooting.....12-3	Steering Stem.....12-12
Steering Handlebar.....12-4	

Mechanism diagram

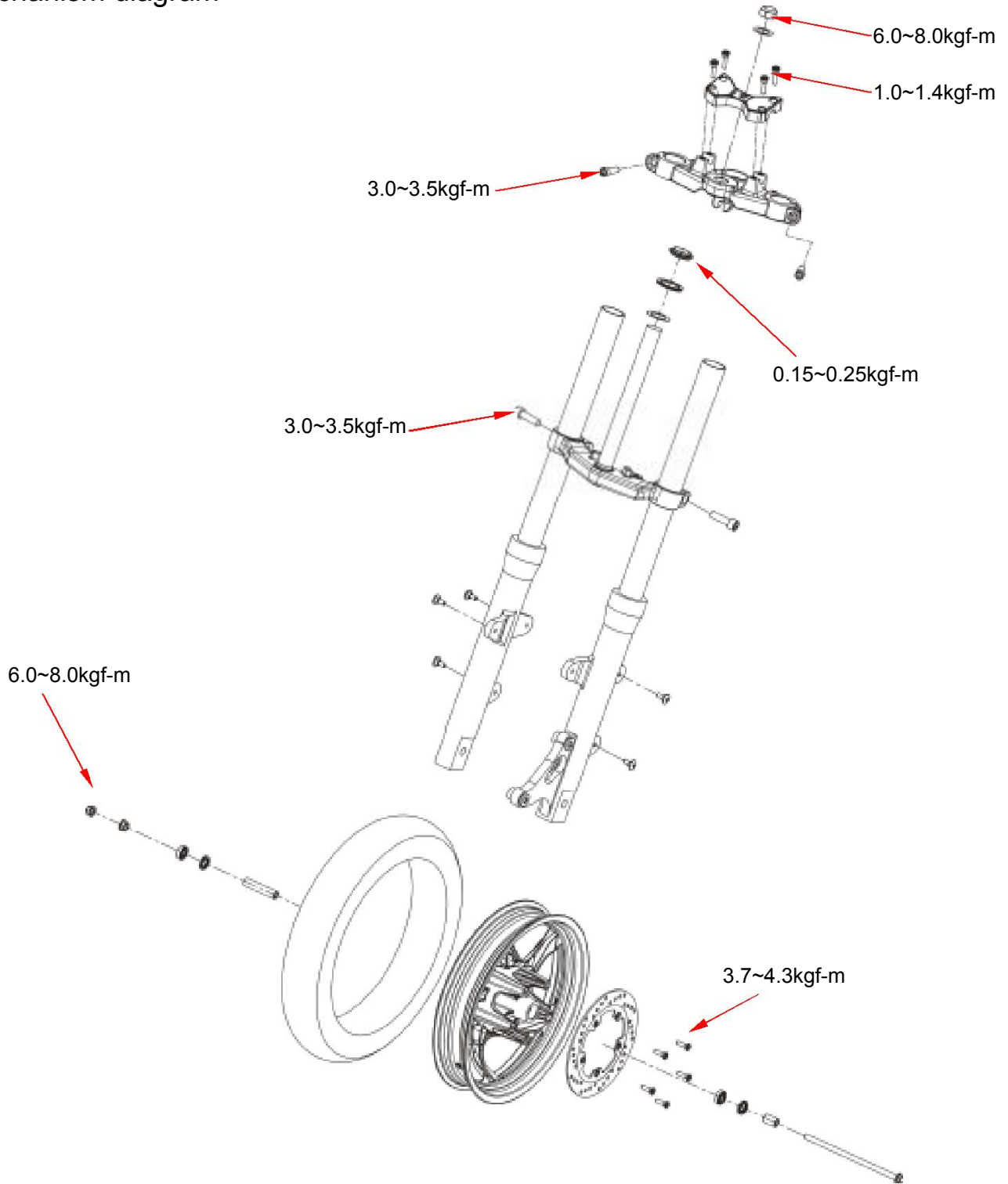

12. STEERING / FRONT WHEEL / FRONT FORK



Precautions in operation

General information

While removing the front wheel, hold the engine bottom with a hanger to lift the front wheel.
During maintaining, do not stain brake pads with any oil or grease.

The brake caliper can be removed without removing the hydraulic system.

After the hydraulic system is removed, or the brake system is felt to be too soft, bleed the hydraulic system.

While refilling brake fluid, care should be taken not to let the foreign material entering the brake system.

Do not spill brake fluid on the painted surfaces, plastic, or rubber parts to avoid damage.
Check the operation of the brake system before riding.

Caution

Inhaling asbestos may cause disorders of respiration system or cancer, therefore, never use compressed air or dry brush to clean brake system. Use vacuum cleaner or other authorized tool instead.

Specification

measurement : mm

Item		Standard	Service limit
Wheel axle runout		—	0.2
Wheel rim runout	Axial	—	2.0
	Radial	—	2.0

Torque value

Front wheel axle locknut	6.0~8.0kgf-m	Front brake hose bolt	3.0~4.0kgf-m
Steering handlebar bolt	1.0~1.4kgf-m	Air bleed valve	0.8~1.0kgf-m
Steering head thread comp	0.15~0.25kgf-m	Brake disk fix bolt	3.7~4.3kgf-m
Steering stem locknut	6.0~8.0kgf-m	Front brake caliper bolt	3.5~4.5kgf-m
Front fork bolt	3.0~3.5kgf-m		

Special tool

Cone race puller

Steel ball race driver 32×35mm

Steel ball race driver 42×47mm

Inner bearing puller SYM-6204020

Steering stem locknut socket wrench SYM-5320000、SYM-5320010

Troubleshooting

Steering mechanism / front fork

Hard steering

Steering stem nut too tight

Worn or damaged steering ball bearing
/ seat

Insufficient tire pressure

Steering handlebar tilted

Incorrect fork adjustment

Bent forks

Bent wheel axle

Damaged tire

Front wheel runout

Bent wheel rim

wheel axle locknut loosened

Worn tire

Worn or damaged front wheel bearing

Soft suspension

Worn fork spring

Fork seal leakage

Hard suspension

Bent fork pipes

Excessive fork fluid

Front suspension noise

Bent fork pipes

Insufficient fork fluid

Loosened suspension

12. STEERING / FRONT WHEEL / FRONT FORK



Steering handlebar

Removal

Loosen the throttle cable locknut. Remove the right handle switch screws. (screw×2) ◦

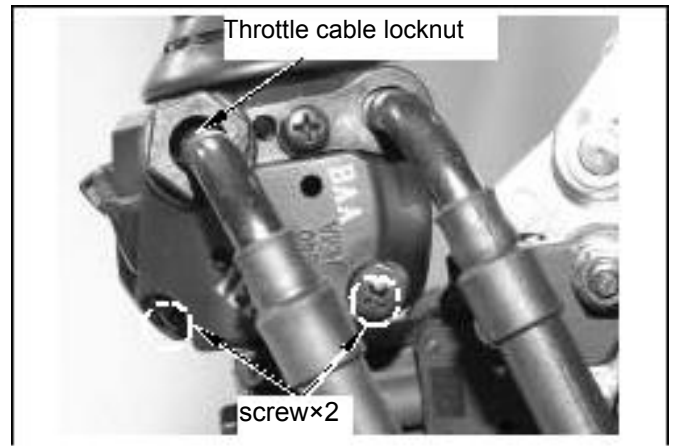

Remove the throttle cable. Remove the throttle grip and right handle switch.

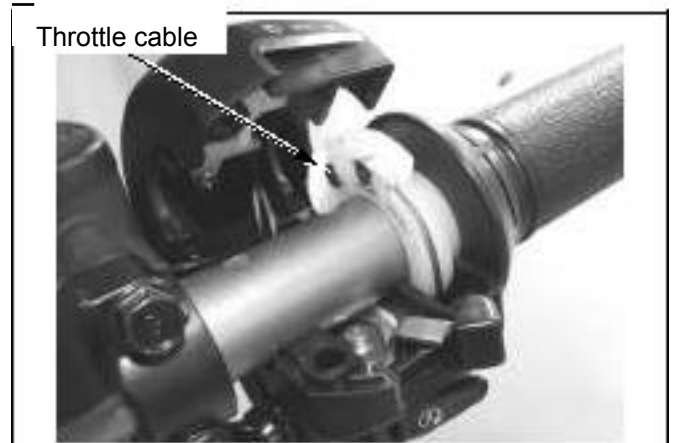

Remove the front brake master cylinder. (bolt x2)

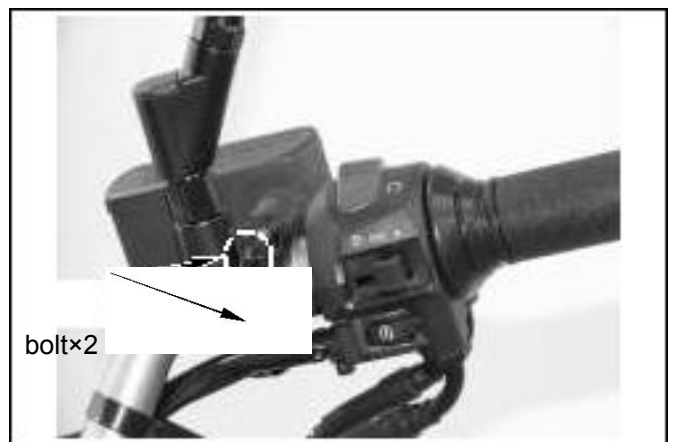

Remove the left handle switch. (screw x2)

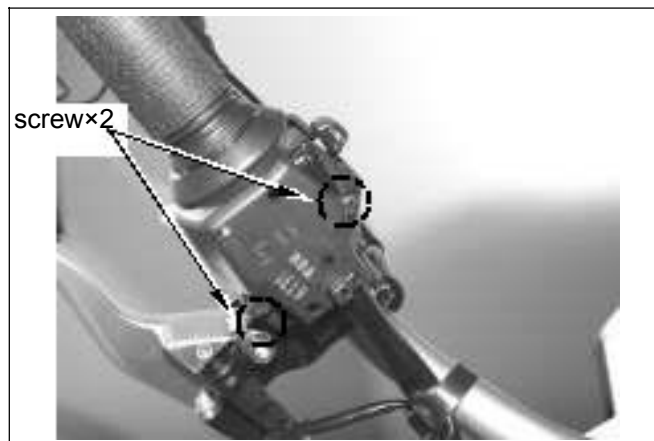

Loosen the clutch cable locknut and adjusting nut.

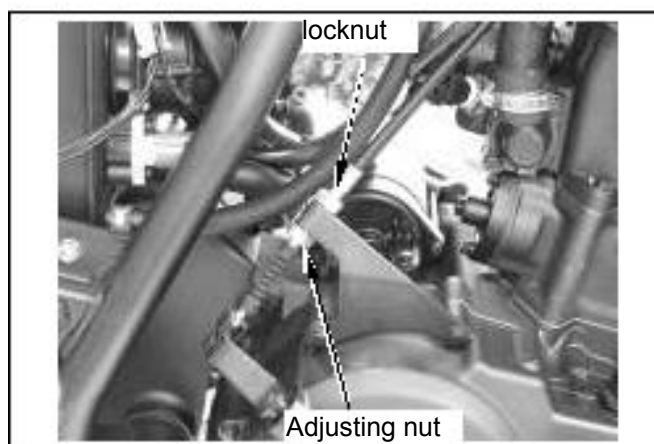

Remove the clutch lever pivot bolt.
Remove the clutch lever and clutch cable.
Remove the clutch lever socket. (bolt x2)
Remove the handlebar bolts and holders. (bolt x4)
Remove the handlebar.

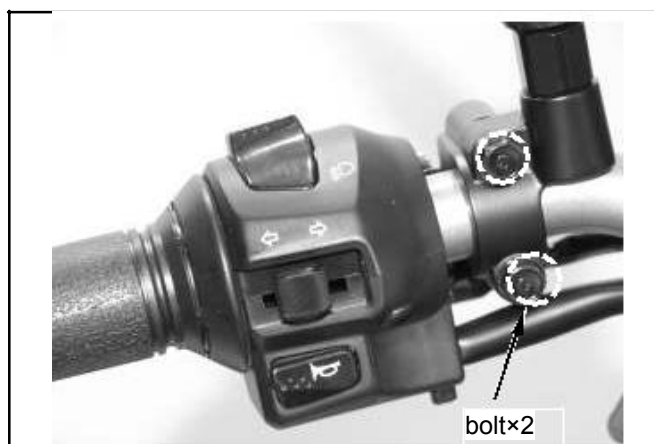

Installation

Install in the reverse order of removal.

Torque value:

Steering handlebar bolt 3.0~3.5kgf-m

Lubricate switches, throttle grip, and throttle cable when installing.

Align the salient on the switch and the intaglio on the handlebar holder.

After the handlebar is installed, confirm and adjust :

- throttle grip operation and free play
- meter, electrical parts operation

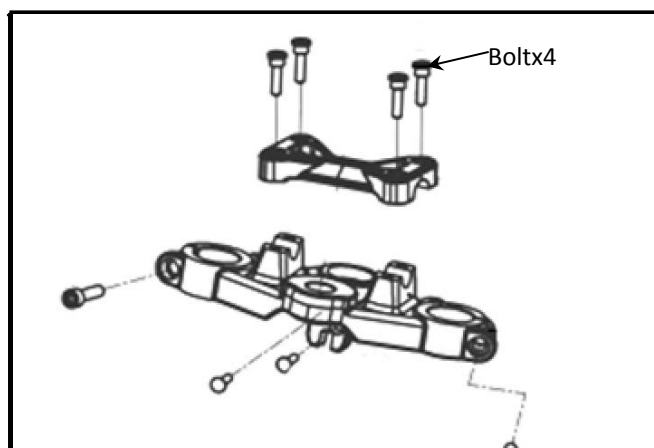

12. STEERING / FRONT WHEEL / FRONT FORK



Front wheel

Removal

Use a bracket to hold the bottom of engine and let the front wheel away from the ground.

Remove the front wheel axle locknut.

Pull out the front wheel axle.

Remove the front wheel and side collar.

Caution

Do not pull the front brake lever when the front wheel is removed to prevent the brake pads from being pushed out.

axle locknut

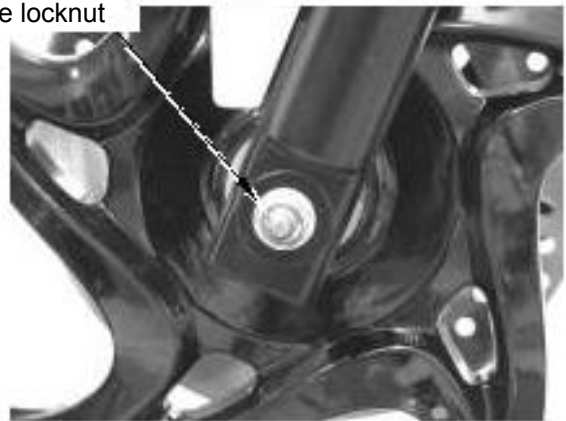

Inspection

Wheel axle

Put the axle on a V-block and measure the run out.

Service limit: 0.2 mm

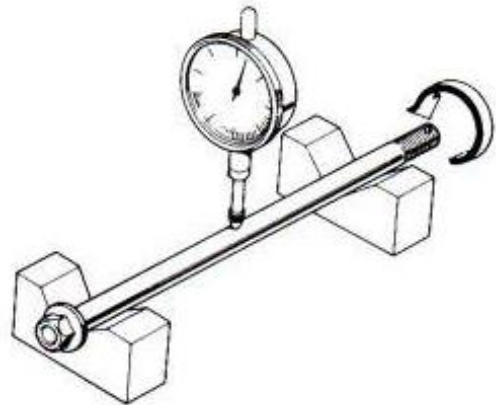

Bearing

Rotate the bearings to check if the bearings rotate smoothly and silently.

Check if the outer ring of the bearing fixes firmly on the wheel hub.

Replace the bearing if there is excessive noise, roughness, or looseness.

Caution

The bearings should be replaced in pair.

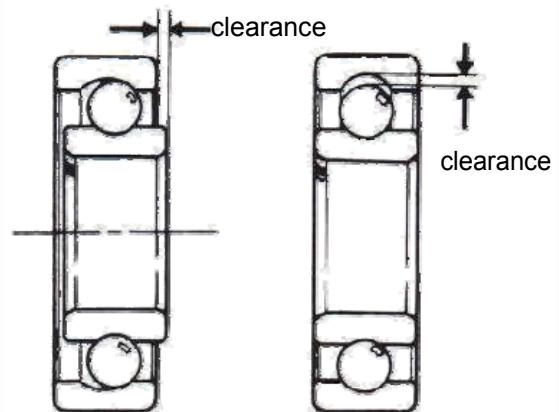

Wheel rim

Place the rim in a rotating stand.

Spin the rim by hand and measure the runout by using a dial indicator.

Service limit: radial 2.0mm

axial 2.0mm

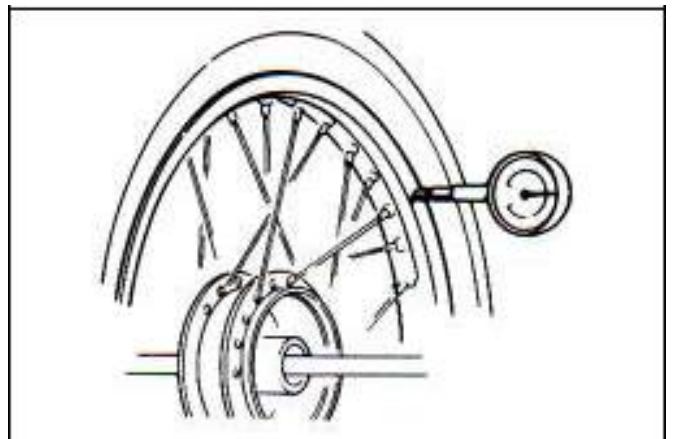

Disassembly

Remove the brake disk. (bolt×5).

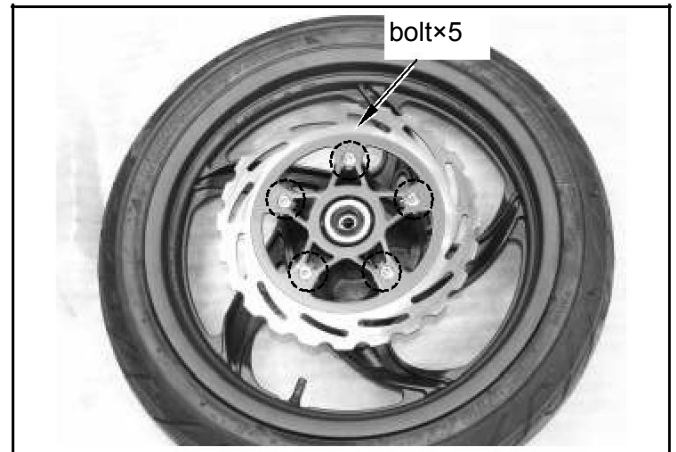

Pull out the left side bearing and oil seal by using the inner bearing puller. Remove the distance collar.

Pull out the right side bearing and oil seal by using the inner bearing puller.

Special tool

Inner bearing puller SYM-6204020

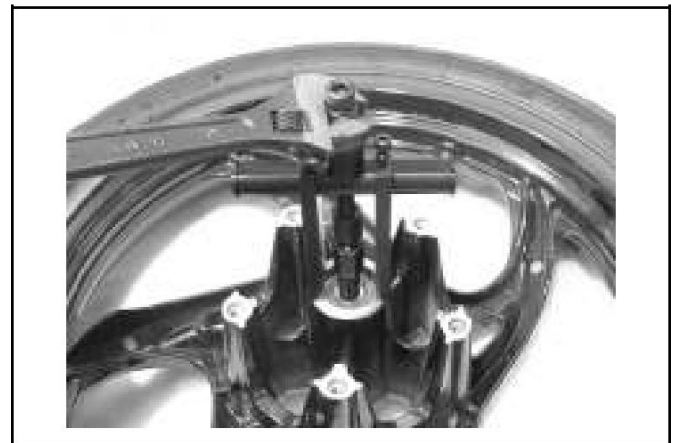

Assembly

Install in the reverse order of removal.

Apply grease to the wheel hub / bearing contact surface.

Install the left side bearing.

Install the distance collar and the right side bearing.

Caution

Do not use a used bearing; replace the bearings in pair when removed from wheel hub.

The bearing cannot lean to one side during installation.

Tool:

Bearing driver

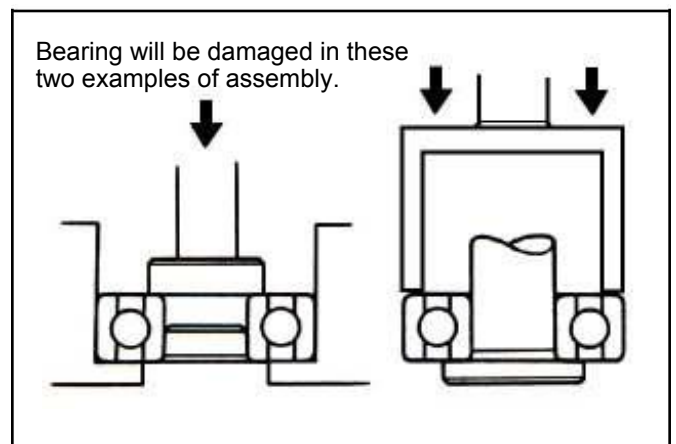

12. STEERING / FRONT WHEEL / FRONT FORK



Installation

Apply grease to the inner and outer side of oil seal and install oil seal into the wheel hub.

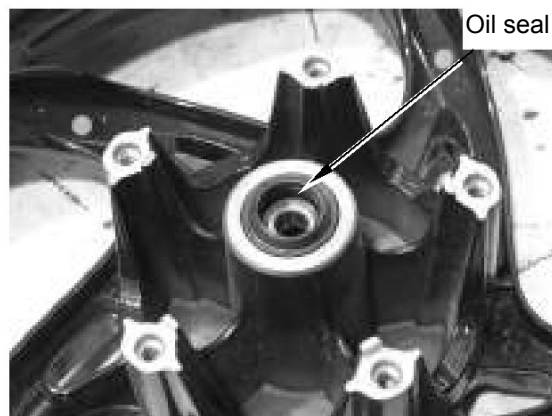

Install brake disk. (bolt×5) ◦
Torque value: 1.4~1.6kgf-m
Install side collar.

Caution

Contaminated brake pad will decrease braking efficiency; therefore grease cannot be applied to brake pad and brake disk.

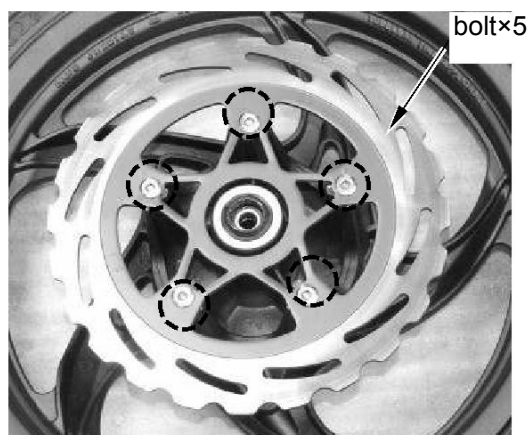

Install the front wheel axle from the right cushion.
Install the axle locknut and tighten the locknut to the specified torque.
Torque value: 6.0~8.0kgf-m

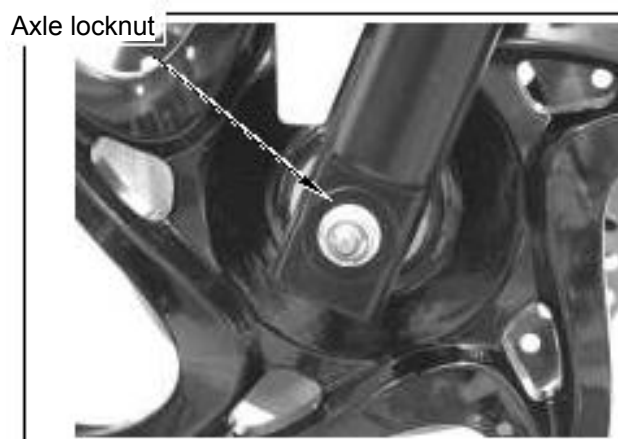

12. STEERING / FRONT WHEEL / FRONT FORK

SYM

Speed sensor

Front fork

Disassembly

Remove the front wheel, speed sensor and front brake caliper.

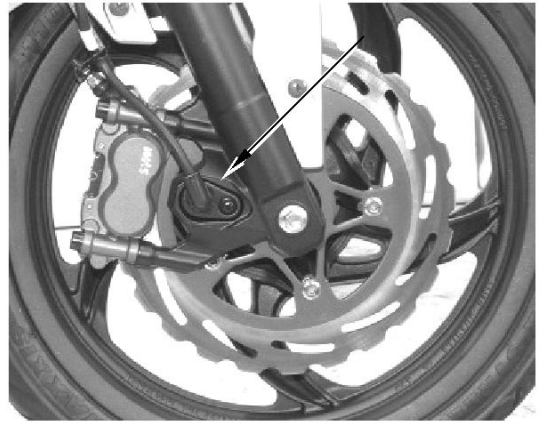

Remove the front fender. (bolt×6)

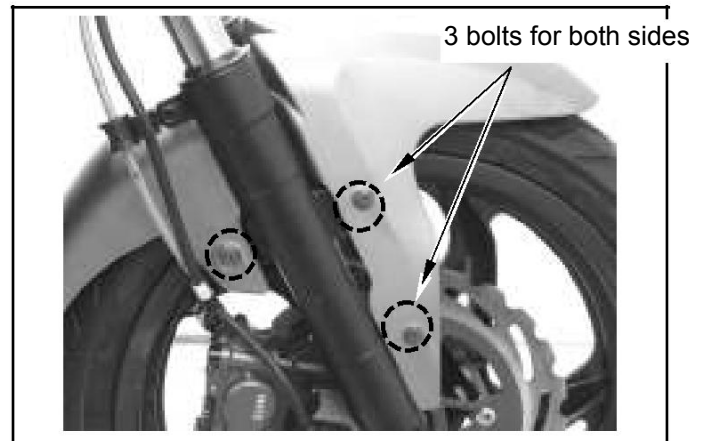

Loosen the front fork bolt on the top bridge. (bolt×2)



Loosen the front fork bolt on the steering stem. (bolt×2) Remove the front fork

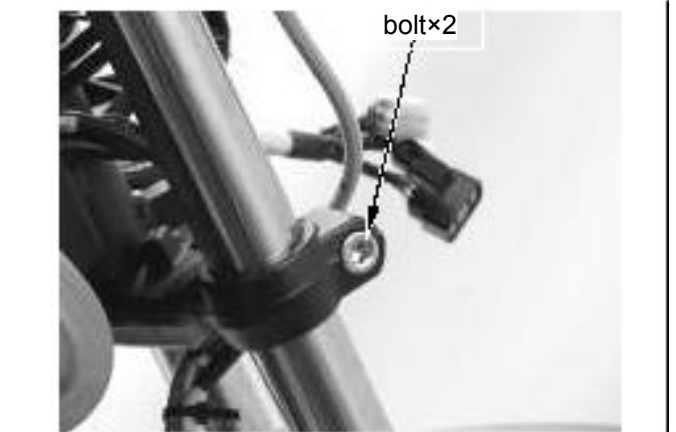

12. STEERING / FRONT WHEEL / FRONT FORK



Front fork inspection / oil seal replacement

Push the fork pipe for several times to check if there is any oil leakage or excessive noise. Check if there is any scratch on the fork pipe if oil leakage happens. Replace the front fork if there is a scratch on the fork pipe.

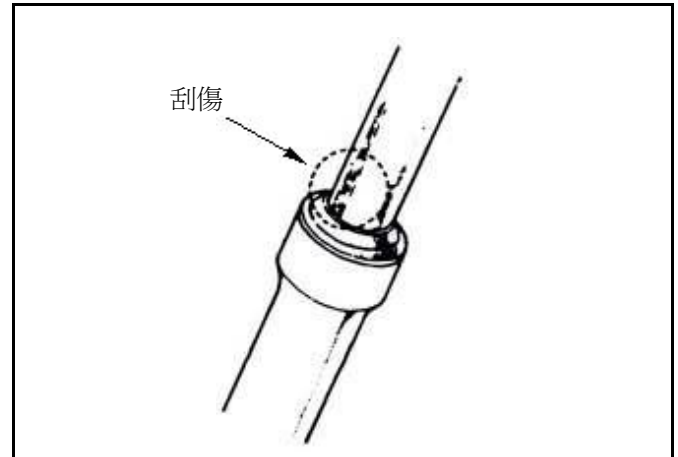

If there is oil leakage but without scratch on the fork pipe, replace the oil seal. Pour out the fork fluid.

Remove the oil seal stopper ring and then remove the old oil seal.

Caution

Do not damage the fork pipe when removing the oil seal.



Coat the inner side of the new oil seal with cushion oil and then put in the fork pipe. Oil seal
Install the oil seal to the right position by using an oil seal driver.
Clip the stopper ring.

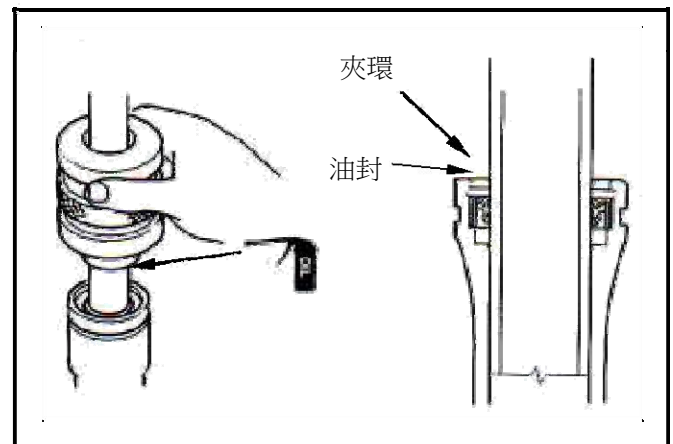

Adjust the fork fluid capacity if the front fork is too hard or too soft.

Cushion oil: BRAMAX CUSHION OIL

Capacity: 160~180c.c.

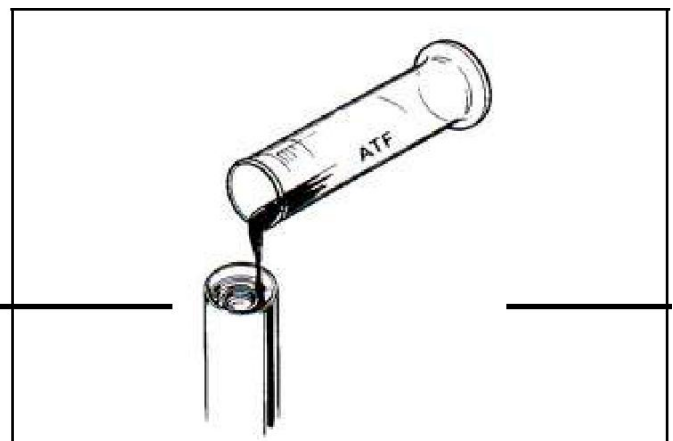

Installation

Caution

The installing will be easier by rotating the fork pipe.

Install the fork pipe from the bottom of the front fork. Align the fork pipe cap with the top bridge.

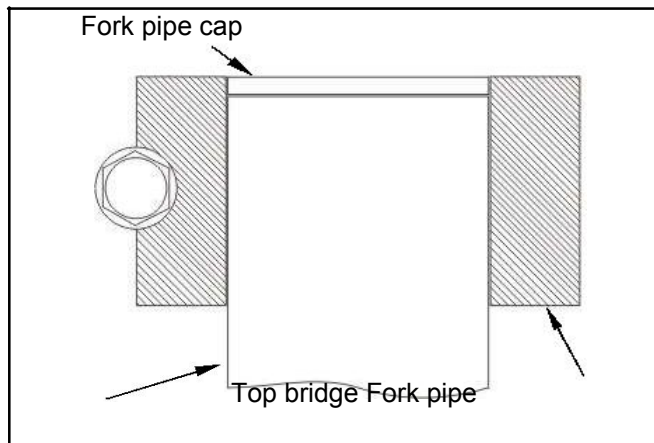

Hold the fork pipe by hand and tighten the front fork upper bolt. (bolt×2)

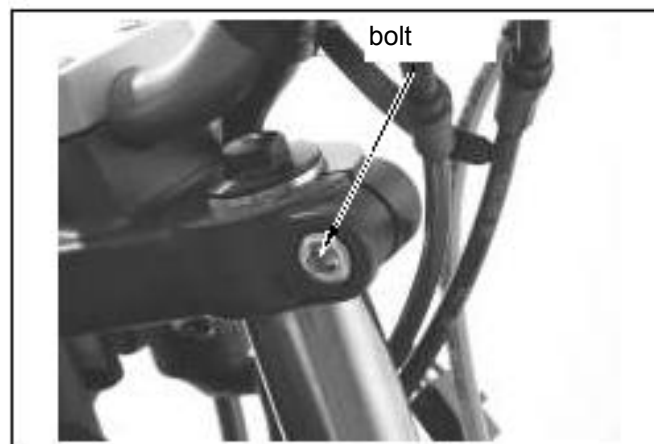

Tighten the fork bolt on the steering stem. (bolt×2)
Torque value: 3.0~3.5kgf-m

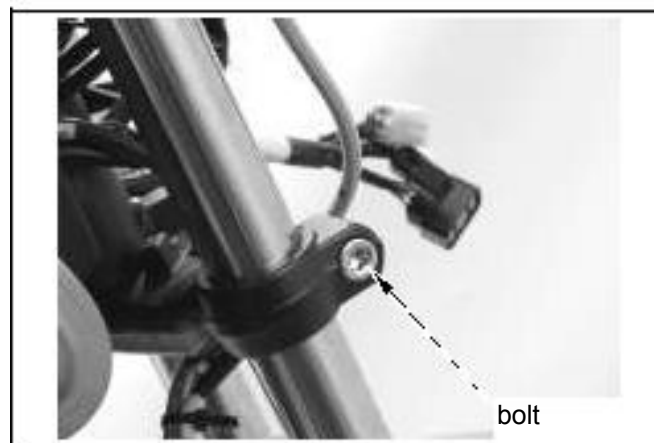

Tighten the front fork upper bolt. (bolt×2)
Torque value: 3.0~3.5kgf-m

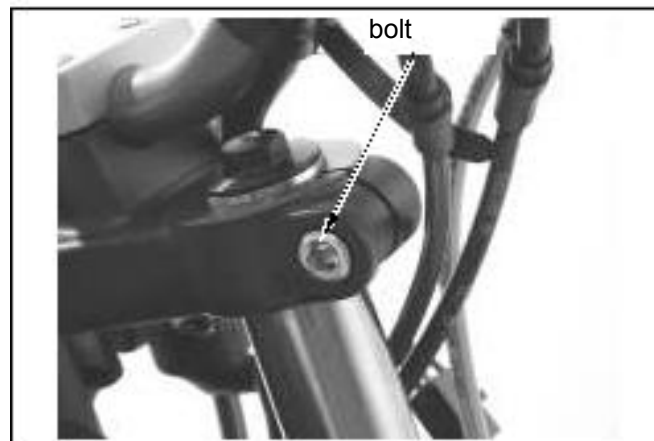

12. STEERING / FRONT WHEEL / FRONT FORK



Steering stem

Removal

Remove the meter, headlight, steering handlebar, front wheel, front brake and front fork.

Remove top bridge locknut. (nut×1)

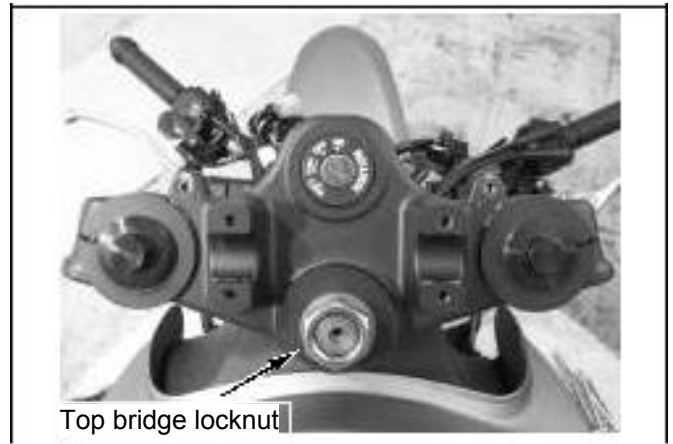

Remove the steering stem locknut and steering upper cone race by using stem locknut socket wrench.

Special tool:

Stem locknut socket wrench SYM-5320000

Remove the steering stem.

Caution

Keep the steering steel balls in a container to avoid missing them.



Remove the steering upper ball race by rubber hammer.

Remove the steering bottom ball race by driver.

Remove the steering bottom cone race from the steering stem.

Caution

Do not damage the frame and steering stem.

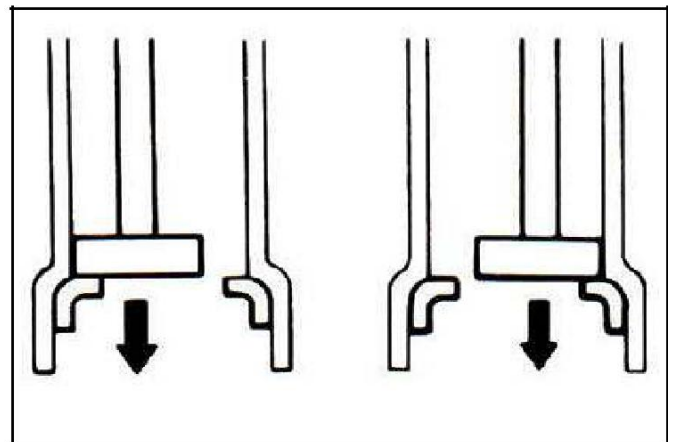

Installation

Install a new steering bottom cone race onto the steering stem and lubricate with grease. Install the steering upper / bottom ball race to steering stem locknut. Bottom ball race the right position.

Caution

Do not let the ball race lean on one side Upper ball race during installation.

Coat the upper / bottom ball race with grease and install the steering balls.

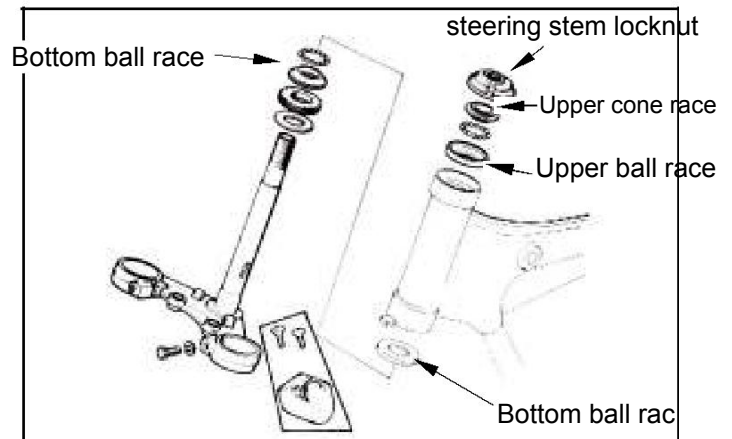

12. STEERING / FRONT WHEEL / FRONT FORK



Install the steering stem into the frame.
Lubricate the steering upper cone race. Tighten the upper cone race and steering stem locknut to the steering stem till the steering balls touch the upper cone race closely.

Turn the upper cone race counterclockwise 1/2 circle and then tighten it with specific torque value.

(1/4~3/8 circle)

Special tool:

Stem locknut socket wrench SYM-5320000

Top bridge locknut socket SYM-5320010

Torque value: 0.15~0.25kgf-m



Caution

- Do not over tighten upper cone race or
- the steering ball race may be damaged.

Install the top bridge and tighten the nut.

Torque value: 6.0~8.0kgf-m



Caution

- After installation, check if the steering stem rotate freely without vertical clearance.

Install other parts in the reverse order of removal.

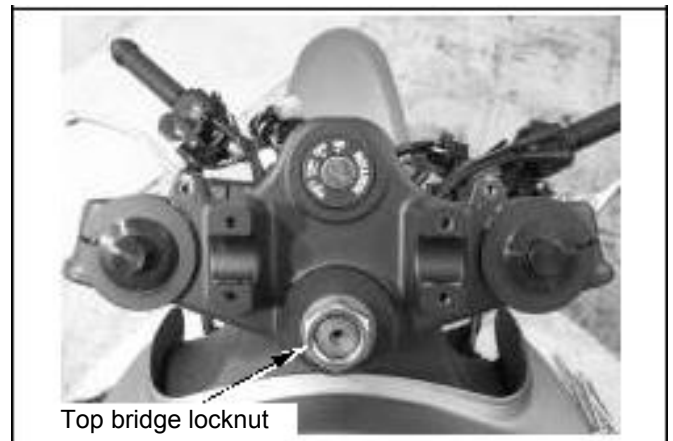
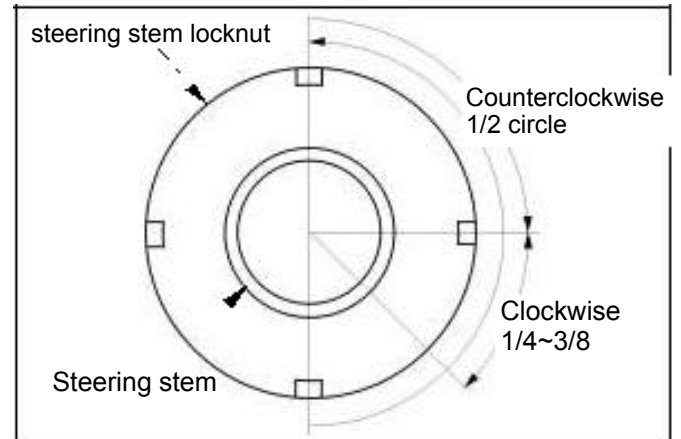

NOTE:

Mechanism Diagram.....13-1	Drive Chain / Sprocket / Flange 13-6
Precautions in Operation13-2	Rear Cushion13-9
Troubleshooting13-2	Swingarm13-10
Rear Wheel.....13-3	

Mechanism diagram

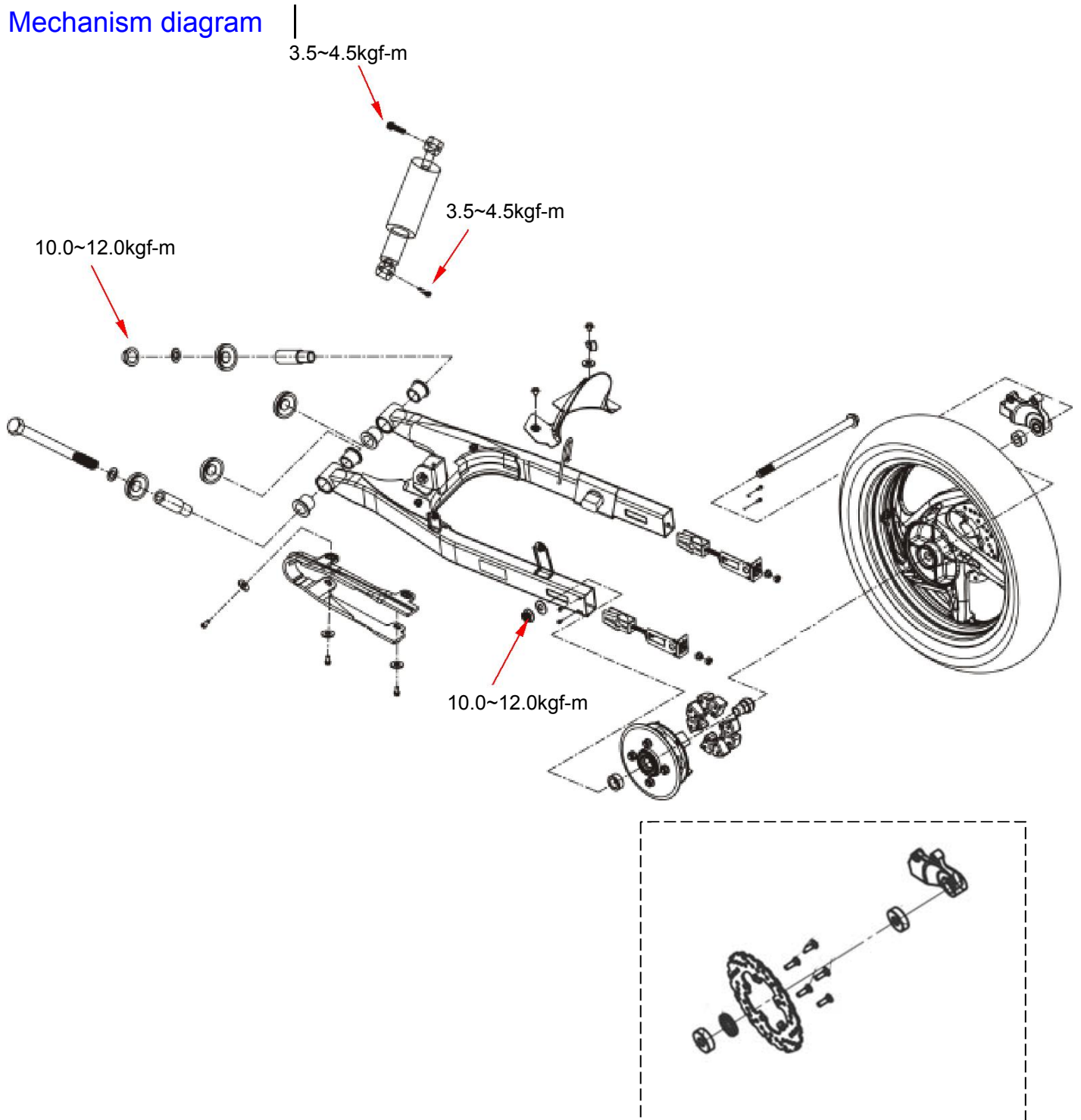

Precautions in operation

General information

Refer to the service manual of tire for the information of tire removal, repair and installation.

Specification

measurement: mm

Item	Standard	Service limit
Axle runout	—	0.2
Wheel rim runout	Radial	2.0
	Axial	2.0
Drive chain slack	—	10~20

Torque value

Rear drive sprocket bolt	2.7~3.0kgf-m
Rear wheel axle nut	10.0~12.0kgf-m
Rear cushion upper bolt	3.5~4.5kgf-m
Rear cushion lower bolt	3.5~4.5kgf-m

Special tool

Inner bearing puller	SYM-6204020
Stem locknut socket wrench	SYM-5320000
Rubber bush puller / driver	SYM-1120310

Troubleshooting

Rear wheel wobbling

- Bent rim
- Faulty rear tire
- Incorrect wheel axle tightening

Rear suspension noise

- Incorrect cushion nut tightening
- Damaged rubber bush
- Cushion fluid leakage
- Bent rear cushion / spring

Too soft suspension

- Weak cushion spring
- Faulty rear cushion

Poor brake efficiency

- Poor brake adjustment
- contaminated brake pad
- Worn brake pad

Too hard suspension

- Damaged rubber bush
- Bent rear cushion

Rear wheel

Removal

Remove the rear brake caliper. (boltX2)

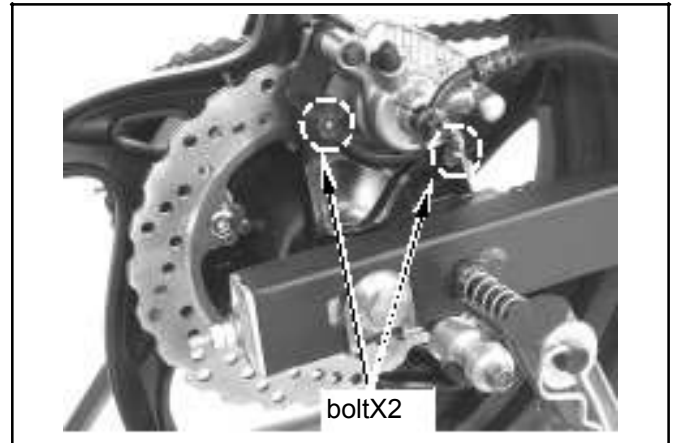

Loosen the drive chain adjusting nuts on both sides.

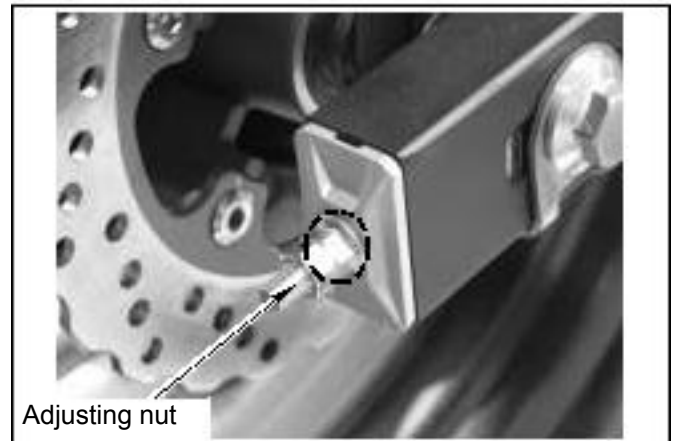

Remove the rear axle locknut.

After removing rear axle, remove the rear wheel, right / left side collar, chain adjuster, and brake disk



13. REAR WHEEL / REAR CUSHION



Inspection

Wheel axle

Put the axle on a V-block and measure the run out.

Service limit: 0.2 mm

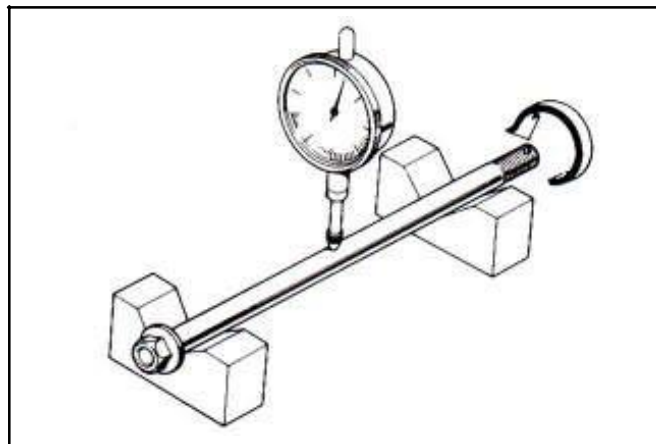

Bearing

Rotate the bearings to check if the bearings rotate smoothly and silently.

Check if the outer ring of the bearing fixes firmly on the wheel hub.

Replace the bearing if there is excessive noise, roughness, or looseness.

Caution

The bearings should be replaced in pair.

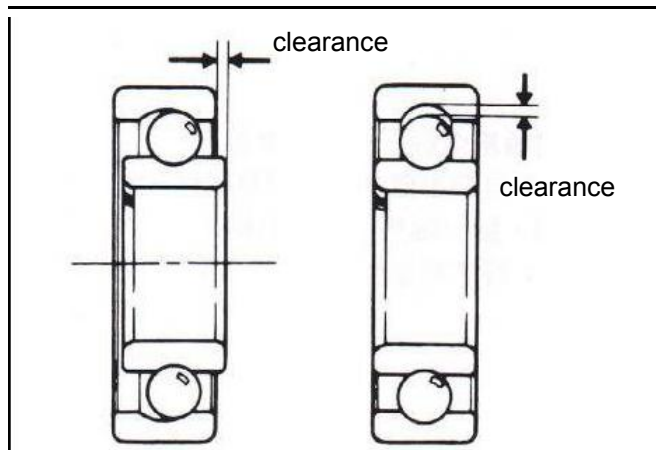

Wheel rim

Place the rim in a rotating stand.

Spin the rim by hand and measure the runout by using a dial indicator. Service limit:

radial 2.0mm

axial 2.0mm

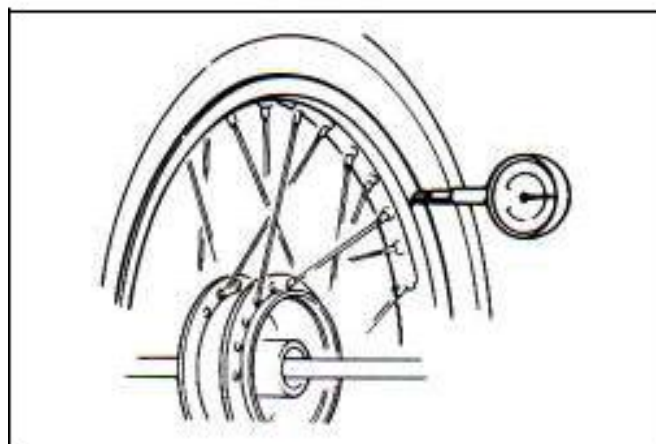

Rear wheel installation

Install in the reverse order of removal.
Adjust drive chain slack. (refer to ch 2)
Tighten rear wheel washer nut.

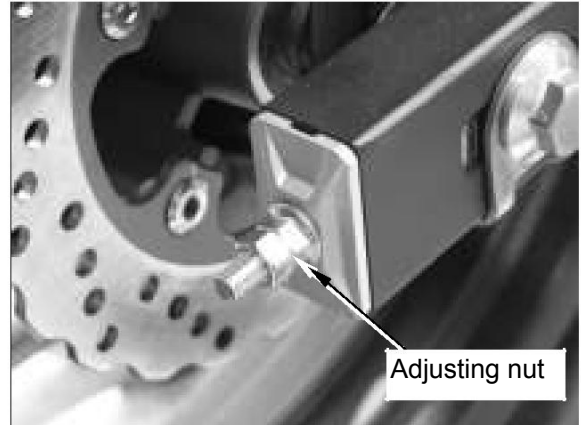

Tighten axle locknut.

Torque value: 10.0~12.0kgf-m



Install the caliper.



13. REAR WHEEL / REAR CUSHION



Drive chain / sprocket / flange

Drive chain / sprocket removal

Remove the left crankcase rear cover. (bolt×2)

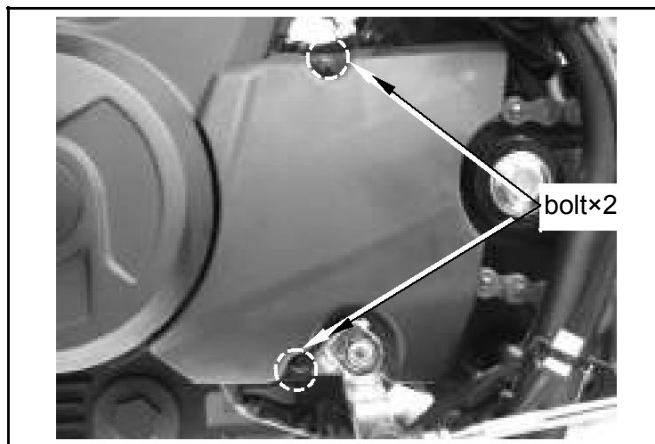

Remove the drive sprocket

bolt s (boltX2),
sprocket fixing plate, and drive sprocket.

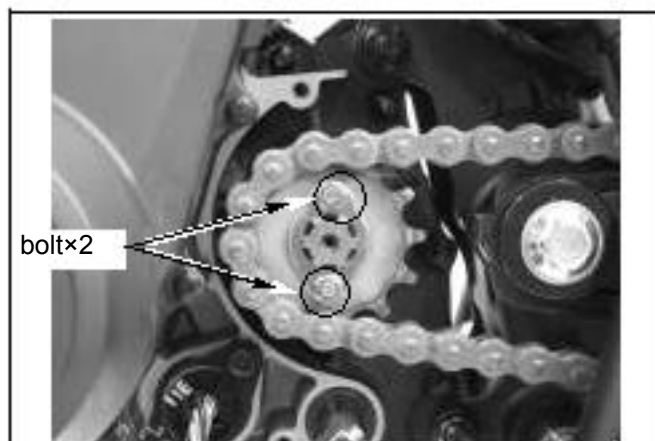

Remove the drive chain cover. (boltX2)

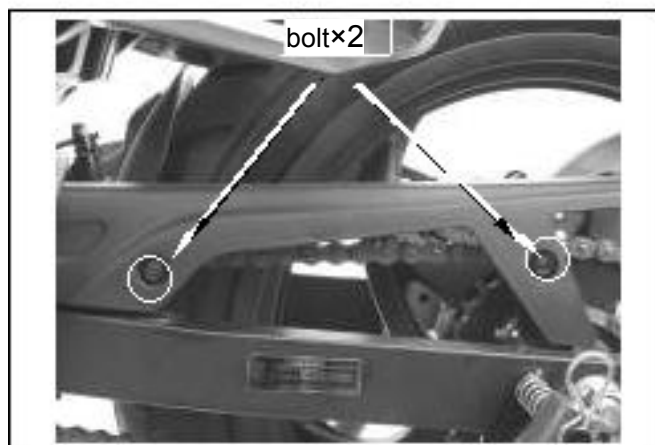

Remove the drive chain fixing clip and
drive chain.

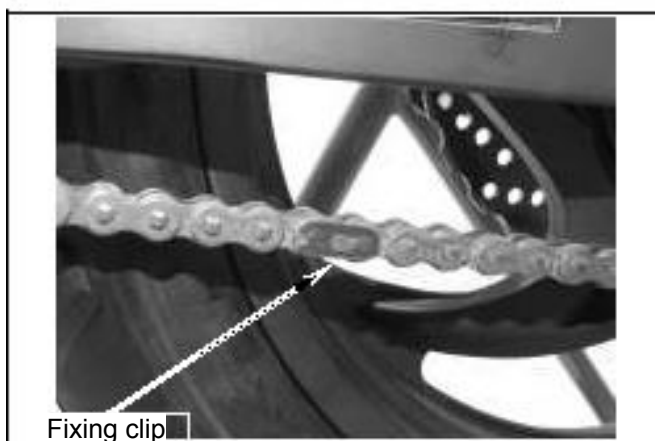

Drive chain / sprocket inspection

Sprocket

Check the condition of sprocket teeth.

Replace the sprocket if the teeth are worn out.

Caution

Sprocket and drive chain condition should be checked at the same time.

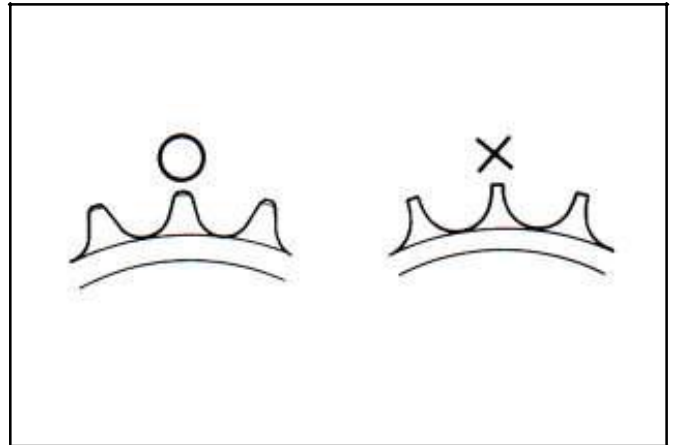

Drive chain

Clean and check the drive chain links condition. Replace the drive chain if it is worn out.

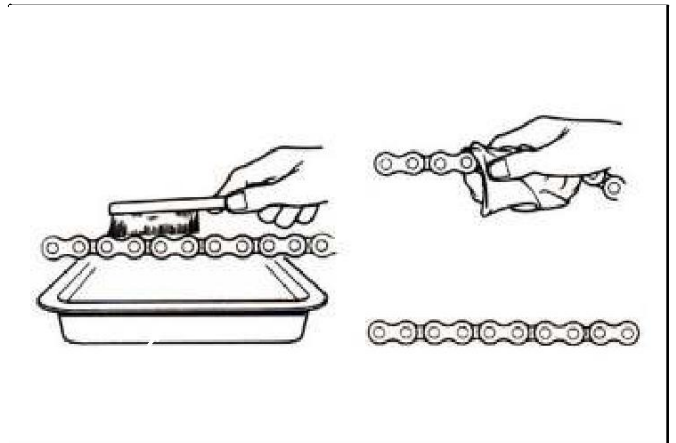

Sprocket / flange removal

Remove rear wheel / drive chain.

Flat the sprocket bolt fixing washer.

Remove sprocket nuts and fixing washer.

Remove the sprocket.

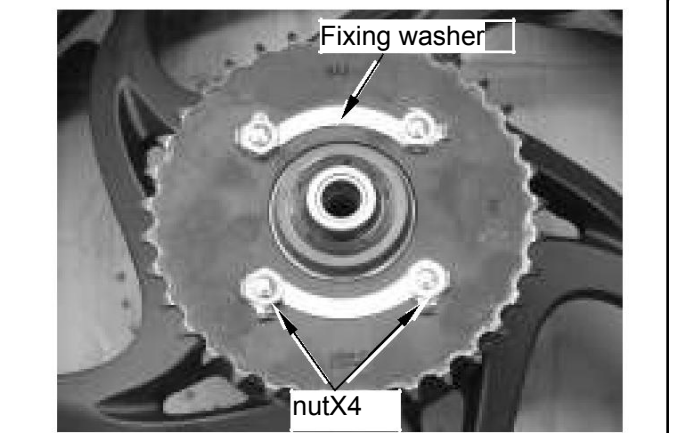

Remove the flange.



13. REAR WHEEL / REAR CUSHION



Damper rubber inspection

Check if the damper rubbers worn or damaged, replace if necessary.

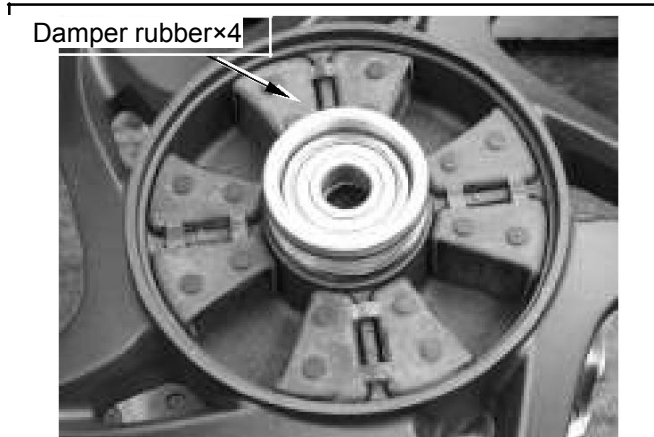

Drive chain adjustment

Turn the left and the right side adjusting nut evenly to make the chain slack within the standard range.

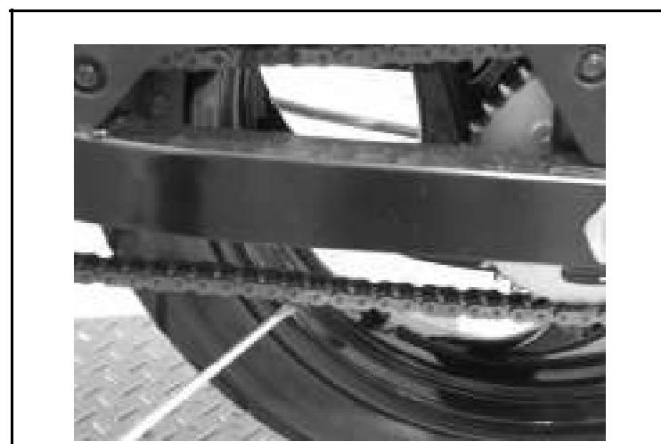

Turn the nuts clockwise to tighten the chain, or counterclockwise to loosen the chain.
Chain slack: 10~20mm

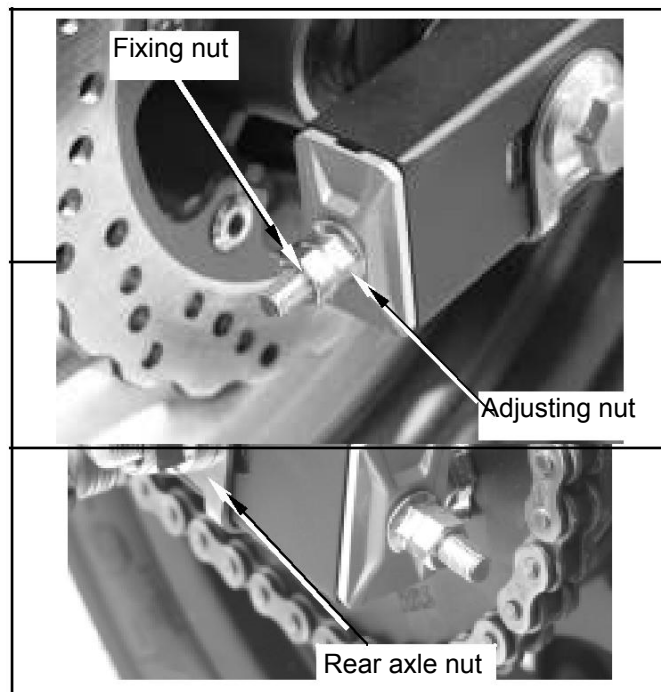

Tighten axle nut.

Torque value: 10.0~12.0kgf-m

After tightening the rear axle nut, please check the adjusting nuts to prevent them from loosening.

Recheck the chain slack, and make sure the rear

wheel rotates smoothly.

Lubricate the chain with chain lubricant.

Rear cushion

Removal

Remove the left body cover.

Remove the fuse / relay bracket. (bolt x2)

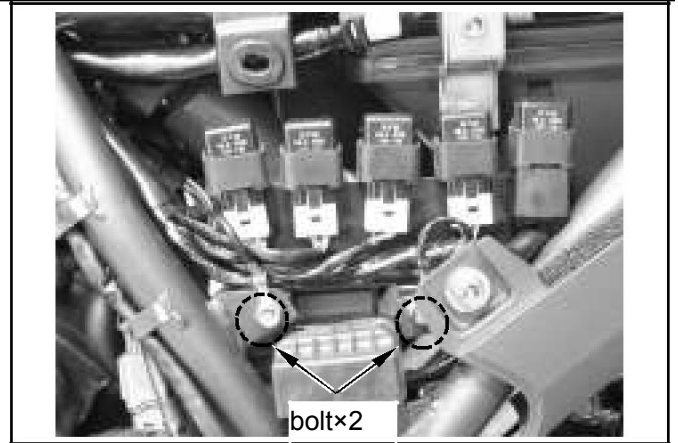

Remove the rear cushion upper bolt. (bolt x1)

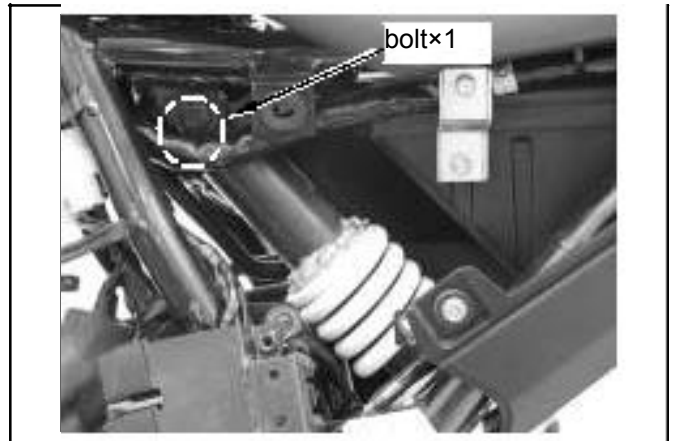

Remove the rear cushion lower bolt.

Remove the rear cushion.

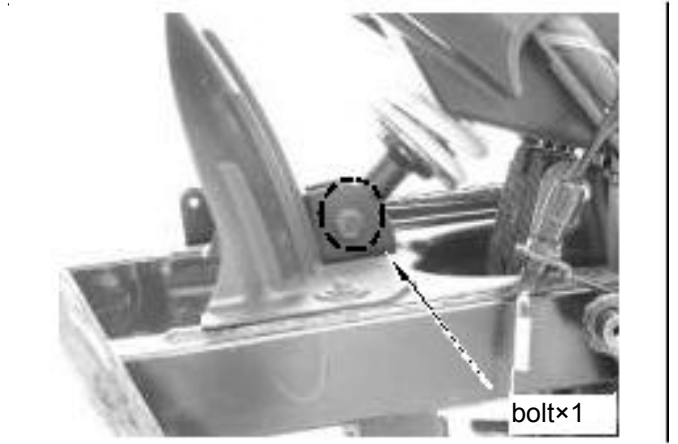

Installation

Install in the reverse order of removal.

Torque value: cushion locknut 3.5~4.5kgf-m bolt x 1

Caution

The rear cushion should be replaced as a complete set. Do not disassemble it, or the structure and rubber bush will be damaged.

Press the rear cushion to check if the rear cushions move freely.

Special tool:

Steering stem locknut socket wrench
SYM-5320000



13. REAR WHEEL / REAR CUSHION



Swingarm

Removal

Remove rear wheel, drive chain, sprocket, and rear cushion lower bolt.

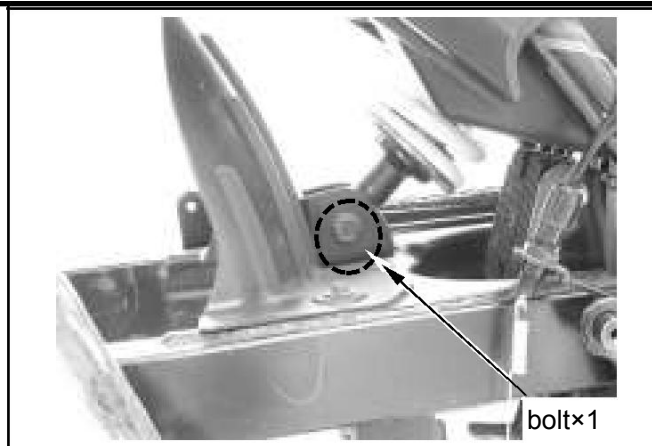

Remove the swingarm pivot locknut. (nut!á1

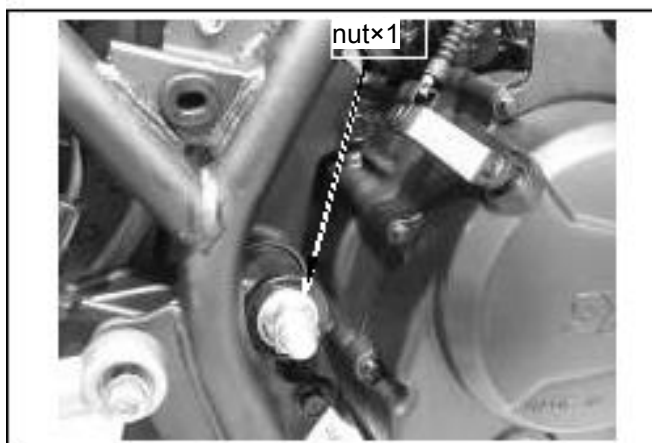

Pull out the swingarm pivot bolt.

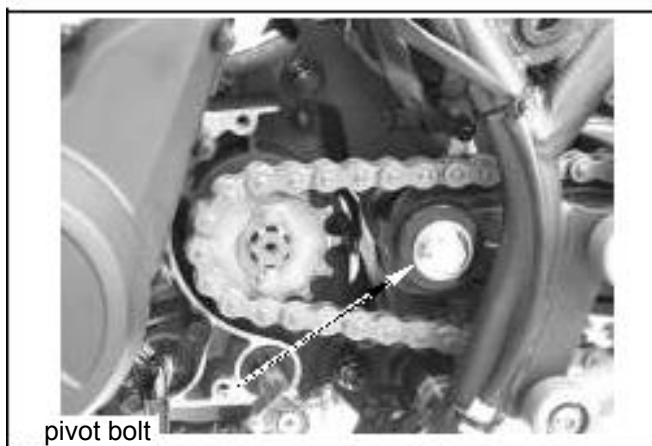

Remove the swingarm pivot sleeve and dust seal.

Swingarm pivot sleeve
Remove the swingarm.

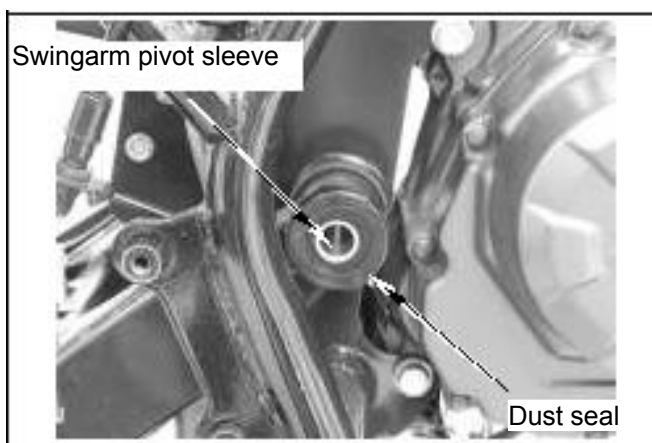

Inspection

Check if the swingarm worn or damaged.

Check if swingarm collars, sleeves and dust seals cracked or worn.

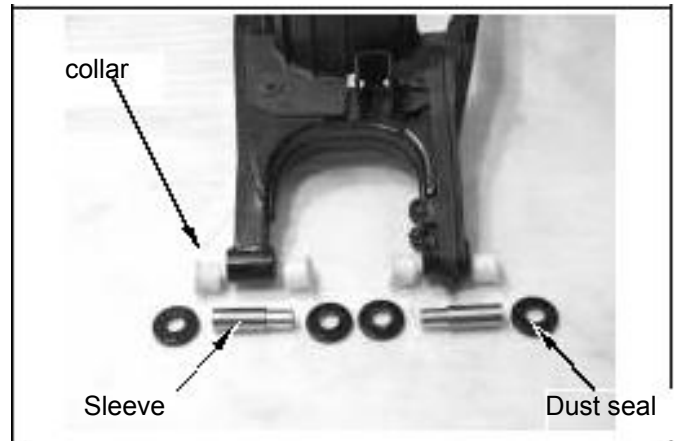

Installation

Install in the reverse order of removal.

Torque value: swingarm pivot locknut
10.0~12.0kgf-m

Caution

The rear cushion should be replaced as a complete set. Do not disassemble it, or the structure and rubber bush will be damaged.

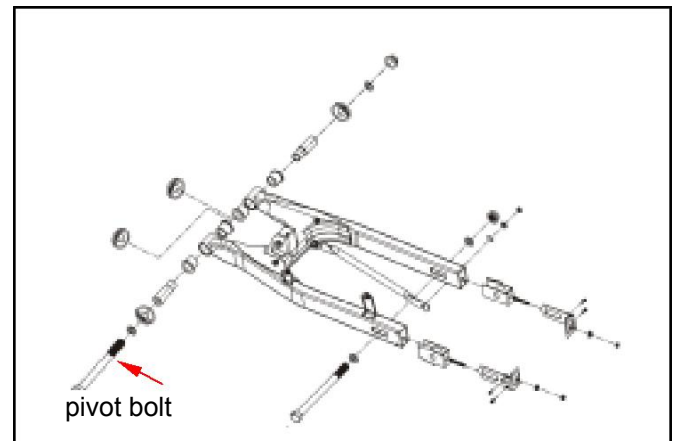

13-2. REAR WHEEL / REAR CUSHION



REAR WHEEL (Drum type)

REAR WHEEL REMOVAL

Raise the rear wheel off the ground on the main stand.
Remove the exhaust muffler.

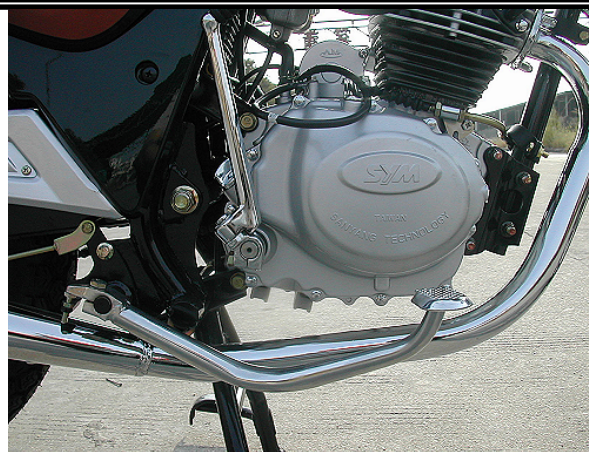

Disconnect the brake rod from the brake arm.
Disconnect the brake torque link from the brake panel.



Remove the axle nut and loose the chain adjusting nut.
Slide out the axle shaft and remove the drive chain from the drive
sprocket, then remove the rear wheel.



AXLE INSPECTION

Set the axle in the V-blocks and measure the runout. The
actual runout is 1/2 of the total indicator reading.
service limit: 0.2mm under

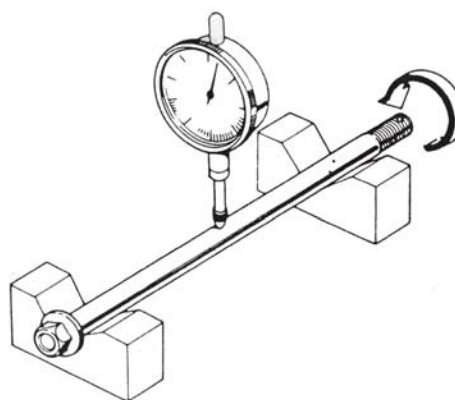

BEARING FREE PLAY INSPECTION

Shake the bearing back and forth and spin it by hand, replace it with a new one if it is noisy or has excessive free play.

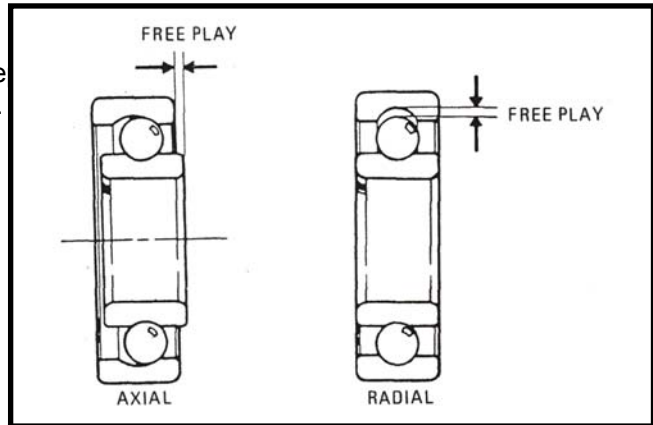

WHEEL RIM RUNOUT INSPECTION

Check the rim runout by placing the wheel in a turning stand. Turn the wheel by hand and read the runout using a dial indicator gauge.

TORQUE: 0.25-0.50 kgf · m

Runout:

Axial: 2.0mm under

Radial: 2.0mm under

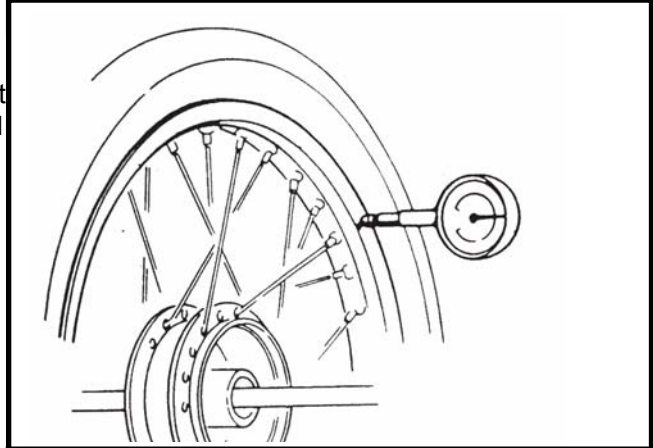

FINAL DRIVEN SPROCKET INSPECTION

Check the condition of the final driven sprocket teeth. Replace the sprocket if it is worn.

NOTE:

The drive chain and drive sprocket must be also inspected for wear.

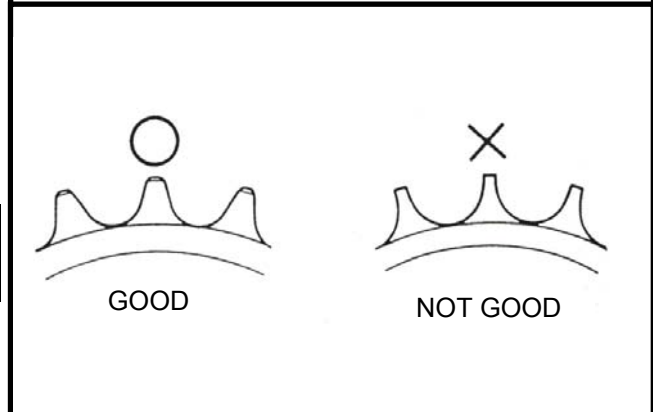

DAMPER RUBBER INSPECTION

Check the damper rubbers for wear or damage and replace if necessary.



FINAL DRIVEN SPROCKET ASSEMBLY

Install the drive sprocket and new lock plates on the drive flange and tighten them with the bolts and nuts.

TORQUE:240~300 kg f • cm

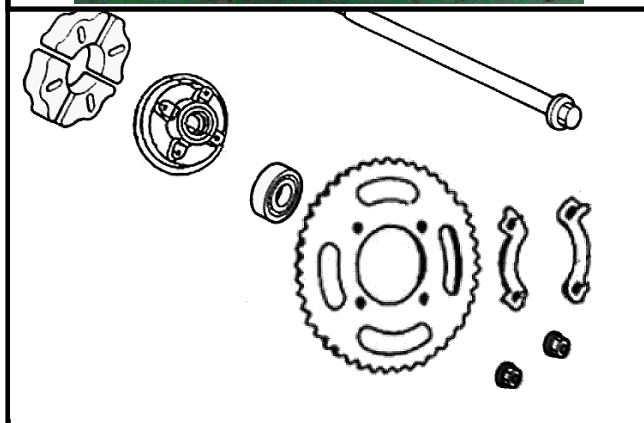

Bend up the lock plate tabs against the nuts.



Install the driven flange on the wheel hub.



Measure the brake drum I.D.
Service limit: ϕ 152mm

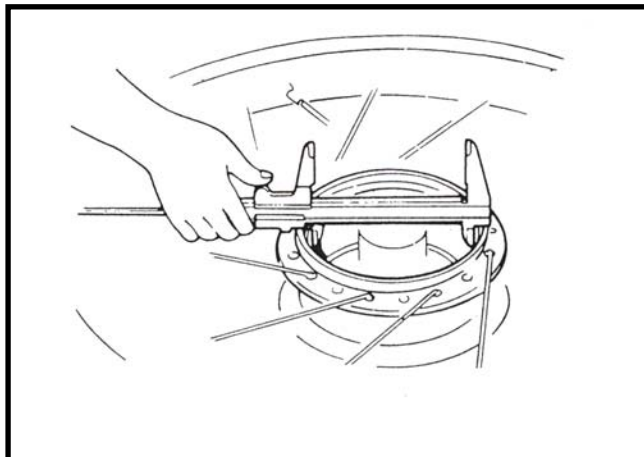

REAR BRAKE PANEL

NOTE:

Grease the place as figure.

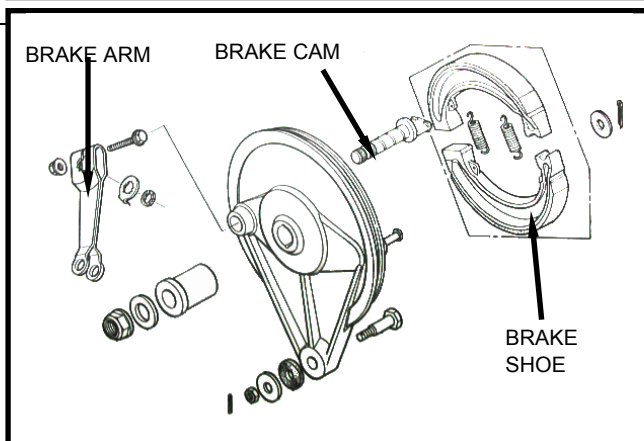

BRAKE SHOE INSPECTION

Measure the lining thickness.
Service limit: 2.0mm

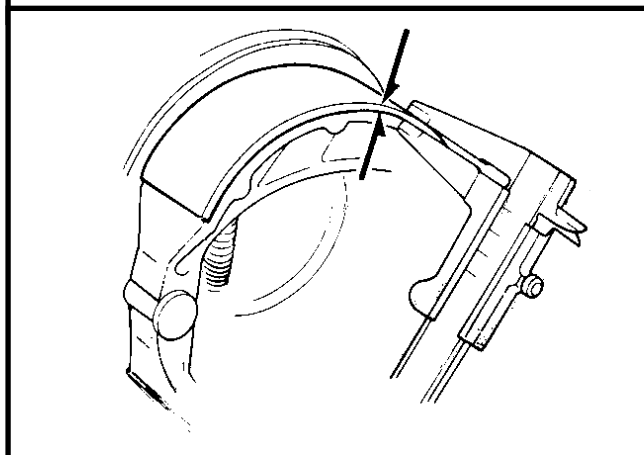

BRAKE SHOE REPLACEMENT

Separate the brake shoes with the brake cam.
Remove the brake shoes and springs.
Grease the brake cam.
Install the new brake shoes.

WARNING:

Contaminated brake lining reduces stopping power.
Keep grease off the lining.



Install the hold arm.
Install the brake linkage.



Adjust the drive chain tension (2-13).
Drive chain slack: 10 ~ 20mm
Tighten the chain tension adjusters.
Tighten the axle nut.
TORQUE: 1000~1200 kg f.cm
Apply engine oil to the drive chain.
Install the step bar and the muffler.

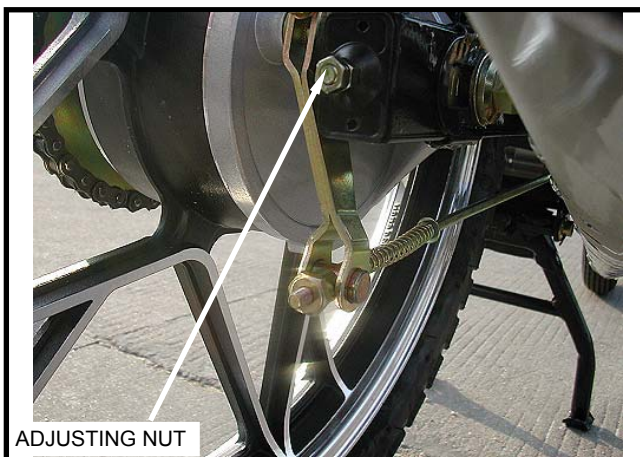

SHOCK ABSORBER SHOCK ABSORBER REMOVAL

Remove the left and right shock absorber assembly.



SHOCK ABSORBER DISASSEMBLY

Compress the shock absorber spring with a shock absorber compressor.

Loosen the lock nut, remove the upper holder.

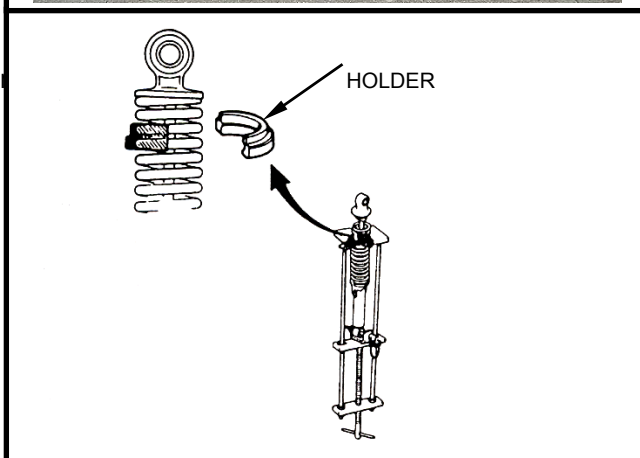

Remove the spring and rubber.

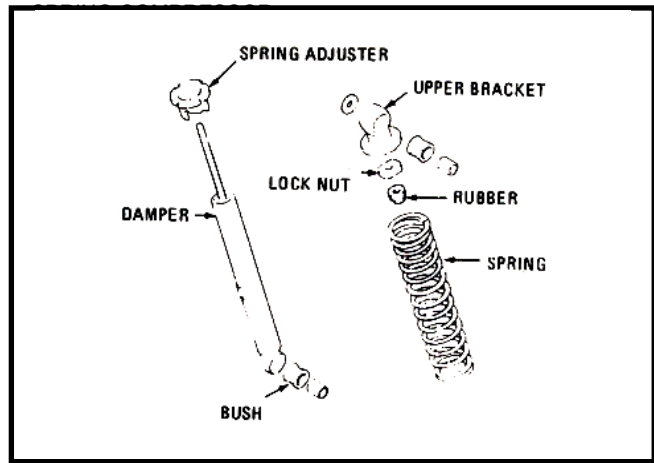

SHOCK ABSORBER SPRING INSPECTION

Measure the shock absorber spring free length.
Service limit: 183mm
Check the shock absorber for noisy or leaks.

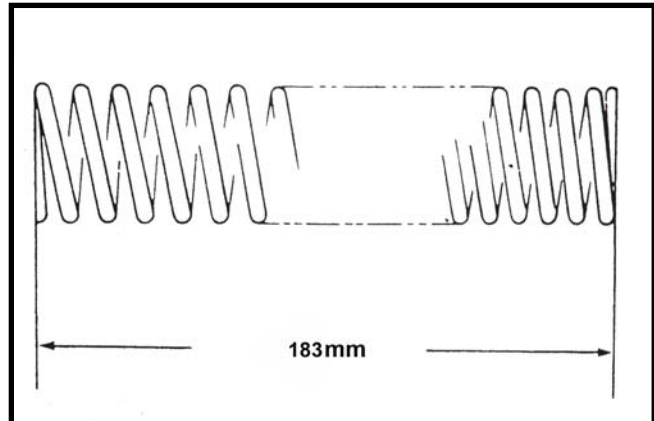

SHOCK ABSORBER ASSEMBLY

NOTE:

Install the spring with the tightly wound coils at the top.

TORQUE: 1.50-2.50kgf • m

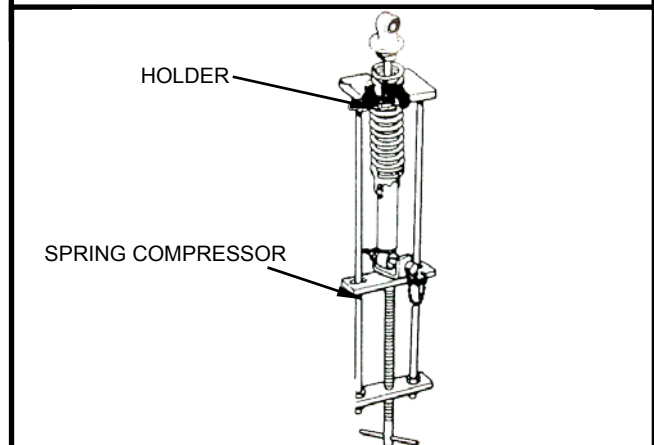

SHOCK ABSORBER INSTALLATION

Tighten the shock absorber upper and lower mounting nuts.

TORQUE: 3.00-4.00 kgf • m

Check the shock absorber operation.

NOTE:

- Adjust the right and left absorber to the same scales.
- The standard position is "1".

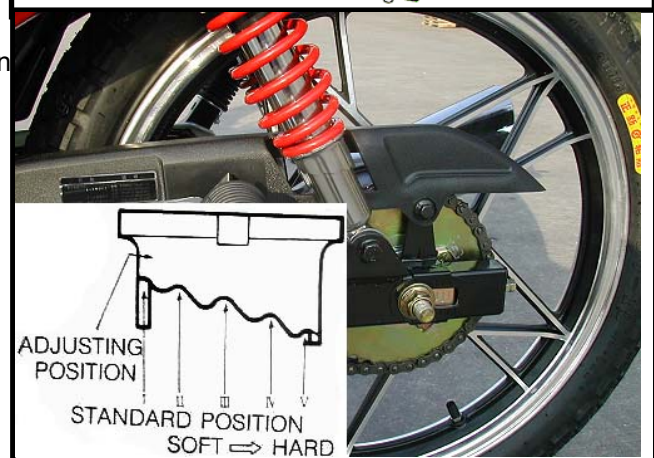

REAR FORK

REAR FORK REMOVAL

- Remove the muffler.
- Remove the rear wheel (12-3).
- Remove the rear shock absorber (12-9).
- Remove the drive chain cover.
- Remove the rear fork mounting bolts.



REAR FORK DISASSEMBLY/ASSEMBLY

NOTE:

Drive the bushings out with a soft hammer, making sure that they are not damaged. Lubricate with grease after installation.

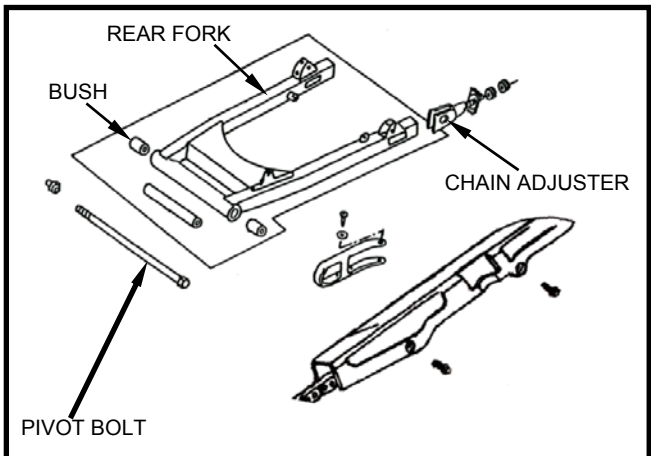

REAR FORK INSPECTION

- Inspect the pivot bushing for cracks or damage.
- Check each part for wear or damage.



REAR FORK INSTALLATION

Install the rear fork.

TORQUE: 8.00~10.00 kgf • m

Install the rear shock absorber and rear wheel.

Install the muffler.



REAR BRAKE PEDAL

Remove the muffler.

Remove the brake linkage rod.

Remove the brake light switch spring.

Remove the brake return spring.



Adjust the rear brake after installation.

NOTE :

Do not forget to install the brake light switch spring.

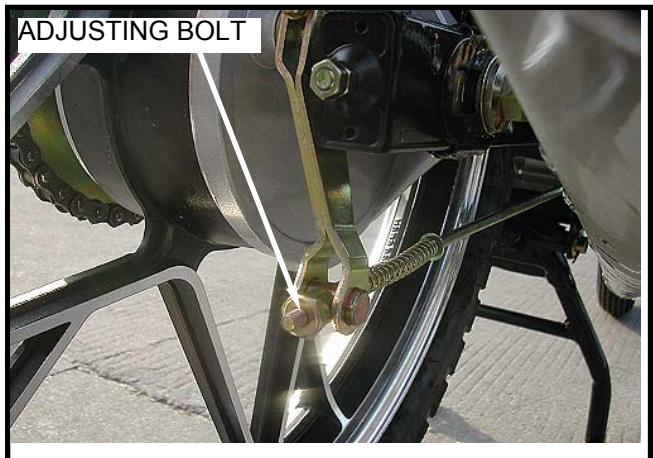

NOTE:

TROUBLE SHOOTING.....	14-1	BATTERY.....	14-3
SERVICE INFORMATION.....	14-2	CHARGING SYSTEM	14-4

TROUBLE SHOOTING

NO POWER --- KEY TURNED ON

1. Dead battery
 - Battery electrolyte evaporated
 - Battery not charged
 - Charging system failure
2. Disconnected battery cable
3. Main fuse burned out
4. Faulty ignition switch

LOW POWER --- KEY TURNED ON

1. Weak battery
 - Low battery electrolyte level
 - Charging system failure
2. Loose battery connection

LOW POWER --- ENGINE RUNNING

1. Battery undercharged
 - One or more dead cells
 - Low battery electrolyte level
2. Charging system failure
3. Generator failure
4. Faulty voltage regulator
5. Faulty ignition coil

INTERMITTENT POWER

1. Loose battery connection
2. Loose charging system connection
3. Loose connection or short circuit in ignition system
4. Loose connection or short circuit in light system

CHARGING SYSTEM FAILURE

1. Loose broken or shorted wire
2. Faulty voltage regulator
3. Faulty generator
4. Battery undercharged

SERVICE INFORMATION

GENERAL INSTRUCTIONS

1. Battery acid level should be checked and refill with distilled water when necessary.
2. When charging the battery, quick-charging should only be done in an emergency; slow charging is preferred.
3. Remove the battery from the motorcycle for charging whenever possible. If battery must be charged on the motorcycle, keep away from flames or sparks.
4. The parts of charging system can be tested on the motorcycle.
5. Refer to section 8 for generator removal and installation.

SPECIFICATIONS

Item		Specification	
Battery	Capacity / Model		12V 6Ah
	Charging rate		Standard:1.2A / 5~10hr
			Rapid:5A / 1hr
	Fully charged	voltage(20°C)	13.0~13.2V
	Need to be charged		12.6V
ACG	Charging output		76W/5000rpm
	Charging rpm		1200rpm max.(Day)
			2400rpm max.(Night)
Rectifier		One-way full wave	
Fuse		15A×3 and 20A×1	

BATTERY

BATTERY REMOVAL AND INSTALLATION

Remove the rear seat.

Disconnect the battery negative cable first, then the battery positive cable.

Disconnect the battery band, remove the battery.

BATTERY INSTALLATION

Put the battery on the battery rack.

Install the battery holder.

Connect the battery positive cable first, then the battery negative cable. Battery Install the rear seat.

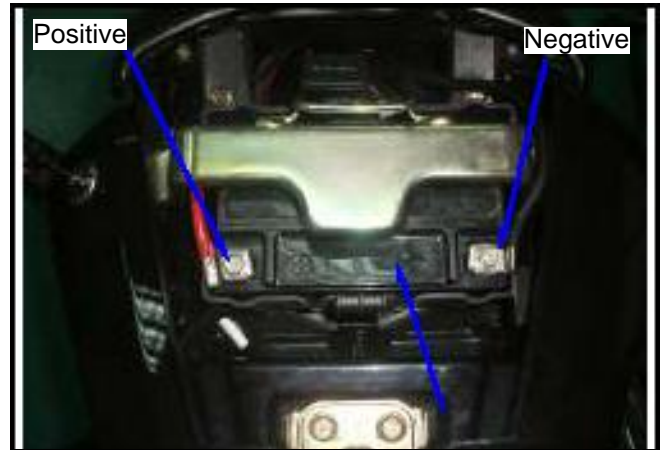

SPECIFIC GRAVITY TEST

Test each cell by using a hydrometer.

SPECIFIC GRAVITY :

1.260-1.280	Fully charged
1.220 or below	Undercharged

(20°C/68 ° F)

NOTE :

- The battery must be recharged if the specific gravity is below 1.23.
- The specific gravity varies with the temperature as shown in the accompanying table.
- Replace the battery if sulfating is evident.
- The battery must be replaced if there are pastes on the bottom of each cell.

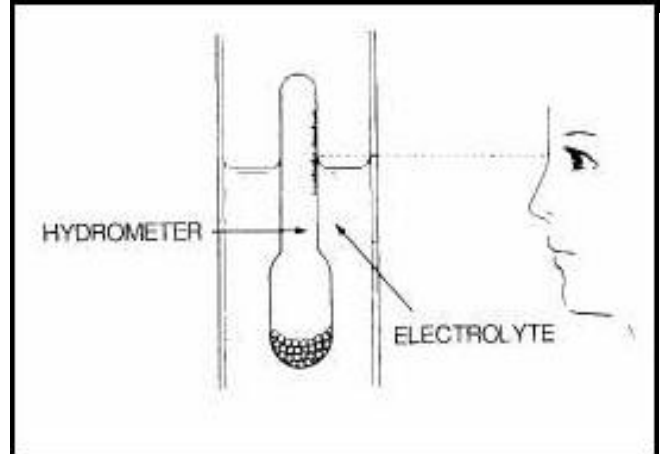

WARNING:

The battery electrolyte contains sulfuric acid. Protect your skin, eyes and clothing. Note the followings:

1. In case of contact, flush thoroughly with water.
2. In case of drinking, drink mass of water or milk, and eat the white of an egg or drink vegetable oil.
3. Cover the eyes when operating at short distance, in case of contact, flush thoroughly with water and spread of eye-ointment.
4. Keep flames and sparks away from a charging battery.
5. Place the charging battery in a ventilated area.

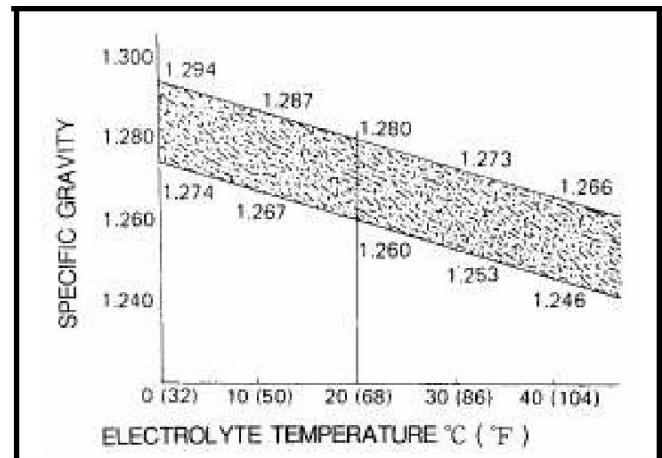

14. BATTERY/CHARGING SYSTEM



Connect the charger positive(+) cable to the battery positive (+) terminal, negative (-) cable to the battery negative (-) terminal.

Charge the battery until the specific gravity of the electrolyte is 1.260-1.280 (20°C/68°F)

Charging current: 0.7A max.

WARNING:

Before charging a battery, remove the cap from each cell.

Keep flames and sparks away from a charging battery.

Connect the cables first, then turn on the power. Discontinue charging if the electrolyte temperature exceeds 45 °C (113°F).

CAUTION:

Quick-charging only be done in an emergency; slow-charging is preferred.

After installed the battery, coat the terminals with clean grease to keep from oxidation.

CAUTION:

Route the breather tube as shown on the battery caution label.

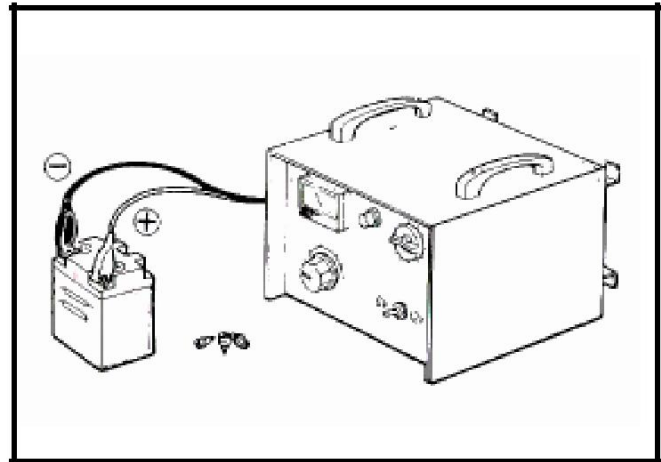

CHARGING SYSTEM

PERFORMANCE TEST

Warm up the engine before taking readings.

Connect a voltmeter and an ammeter to check charging output.

NOTE:

Use a fully charged battery to check the charging system output.

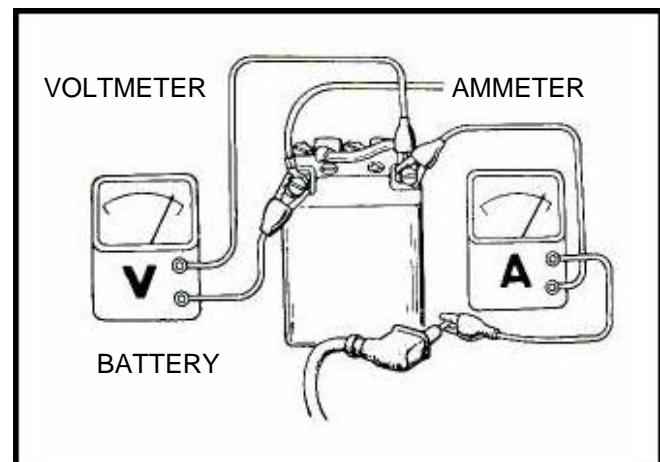

STATOR COILS TEST

NOTE:

This test can be made with the stator on the frame.

Disconnect and measure the A.C. generator connectors with a multi-meter. Conductivity should exist between : Red-green, red-yellow, red-pink. Green-red, yellow-red, yellow-pink should not conduct electricity with ground.

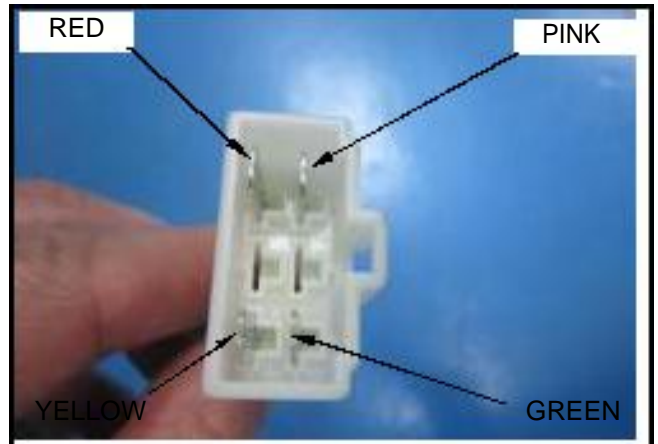

RECTIFIER

Disconnect the rectifier connector and check its performance.

WARNING:

Do not use high voltage power, especially the ohmmeter, or the rectifier will be burnt out.

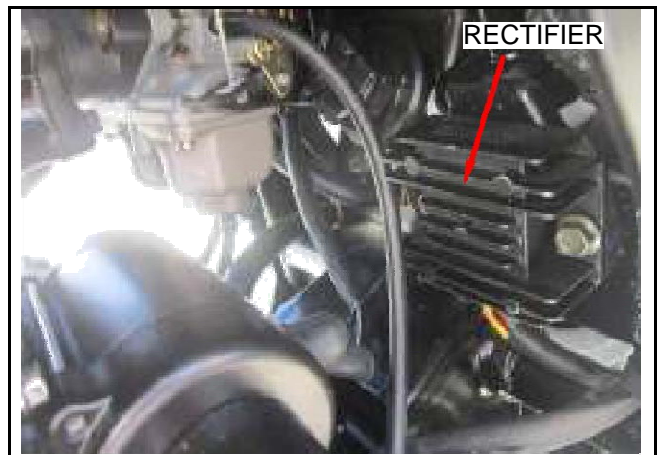

Voltage Regulator Check

Unit: Ω

	black	yellow	yellow	yellow	black	red	green	shell
red								
yellow		∞	∞	∞	∞	4	∞	
yellow		∞	∞	∞	∞	5	∞	
yellow		∞	∞	∞	∞	5	∞	
black		∞	∞	∞	∞	8	∞	
red		5	5	5	∞	12	∞	
green		∞	∞	∞	∞	∞	∞	
shell		∞	∞	∞	∞	∞	∞	

Rectifier is normal if there is continuity only in the direction shown. Replace the rectifier if there is continuity in reverse direction.

TROUBLE SHOOTING.....	16-1	HEADLIGHT SWITCH.....	16-3
SERVICE INFORMATION.....	16-2	START/HAZARD SWITCH.....	16-3
MAIN/DIMMER SWITCH	16-3	FRONT/REAR BRAKELIGHT SWTICH	16-4
WINKER/HORN SWITCH.....	16-3	HORN SWTICH.....	16-4
HEADLIGHT SWITCH.....	16-3		

TROUBLE SHOOTING

NO LIGHTS COME ON WHEN IGNITION SWITCH IS TURNED ON:

1. Battery low
2. Wiring loose or blown
3. Fuse blown
4. Open or shorted wiring
5. Faulty combination switch
6. Bulb at fault or burned out

ALL LIGHTS COME ON BUT DIMLY WHEN IGNITION SWITCH IS TURNED ON:

1. Battery low
2. Wiring or switch has excessive resistance

HEADLIGHT BEAMS DO NOT SHIFT WHEN HIGH-LOW SWITCH IS OPERATED:

1. Faulty dimmer switch
2. Faulty headlight switch

SERVICE INFORMATION

GENERAL INSTRUCTIONS

All electrical wires are color-coded. Check the color before connecting wires.

All plastic plugs have locking tabs that must be released before disconnecting, and must be aligned when reconnecting.

A conductivity check can usually be made without removing the part from the motorcycle by simply disconnecting the wires and connecting a galvanometer or voltmeter to the terminals or connections.

SPECIFICATIONS

Headlight	12V 14W(1LED)/25W(1LED)
Winker light	13.5V 1.8W(3 LEDS)*4
Tail / Stop light	13.5V 5.5W(15 LEDS)
Position light (headlight)	12 V 1.5 W (6 LEDS) * 2
Position light (taillight)	13.5 V 2.5W (15 LEDS)*1

MAIN SWITCH

WIRE COLOR \ SWITCH POSITION	BLACK/WHITE BW	GREEN G	RED R	BLACK B

DIMMER SWITCH

WIRE COLOR \ SWITCH POSITION	BLUE L	WHITE W	BROWN/WHITE Br/W

WINKER SWITCH

WIRE COLOR \ SWITCH POSITION	ORANGE O	GRAY Gr	SKY BLUE SB

HORN SWITCH

WIRE COLOR \ SWITCH POSITION	GREEN G	LIGHT GREEN LG

START SWITCH

WIRE COLOR \ SWITCH POSITION	YELLOW/RED Y/R	BLACK B

ENGINE STOP SWITCH

WIRE COLOR \ SWITCH POSITION	BLACK B	BLACK/RED B/R

FRONT LIGHTBRAKE SWITCH

Check that the front brakelight switch for conductivity between the BLACK and GREEN/YELLOW wires. The switch is normal if there is conductivity with the front brake applied.

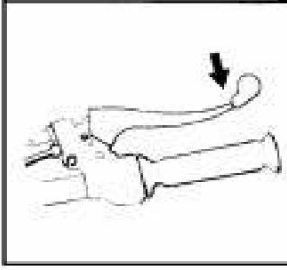
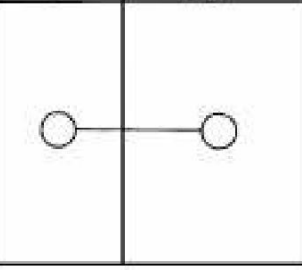
SWITCH \ WIRE COLOR	BLACK B	GREEN/YELLOW G/Y
		

REAR LIGHT BRAKE SWITCH

The switch is normal if there is conductivity with the rear brake applied.

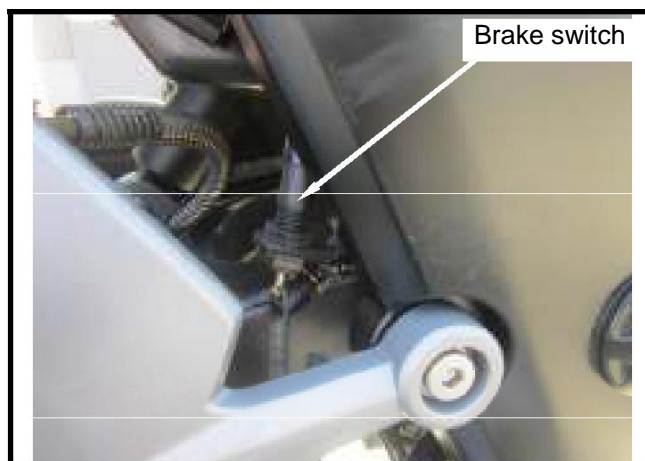

HORN

Connect the horn to a 12V battery for testing its performance. Adjust the horn if the noise is not loud enough.

