

# SERVICE MANUAL



This service manual contains the technical data of each component inspection and repair for the SYM series motorcycle. The manual is shown with illustrations and focused on 「 Service Procedures 」 , 「 Operation Key Points 」 , and 「 Inspection Adjustment 」 so that provides technician with service guidelines.

If the style and construction of the motorcycle are different from that of the photos, pictures shown in this manual, the actual vehicle shall prevail. Specifications are subject to change without notice.

This manual that contains all data, illustration, indication and specifications is based on current production information. SYM reserves the right to make changes at any time without notice and without incurring any obligation whatever. No part of this manual can be duplicated by any means without written permission of SANYANG.

**SERVICE DEPARTMENT  
SAN YANG INDUSTRY CO., LTD.**

---

This service manual describes basic information of different system parts and system inspection & service for SYM series motorcycles. In addition, please refer to the manual contents in detailed for the model you serviced in inspection and adjustment.

The first chapter covers general information and trouble diagnosis.

The second chapter covers service maintenance.

The third to the eleventh chapters cover engine and driving systems.

The twelfth to fifteenth chapters are contained the parts set of assembly body.

The sixteenth chapter is electrical equipment.

The seventh chapter is for wiring diagram.

Please see index of content for quick having the special parts and system information.

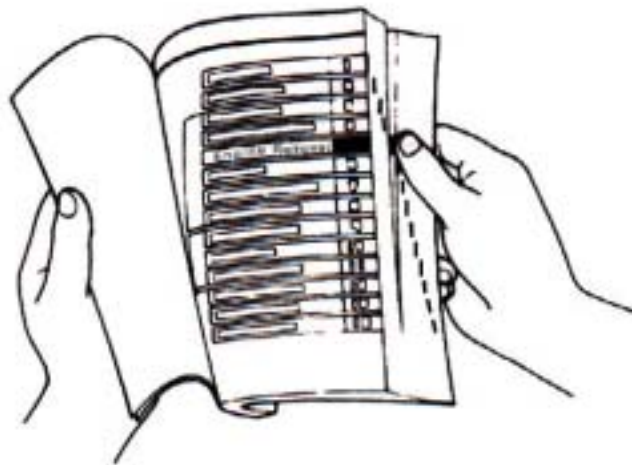

## CONTENTS



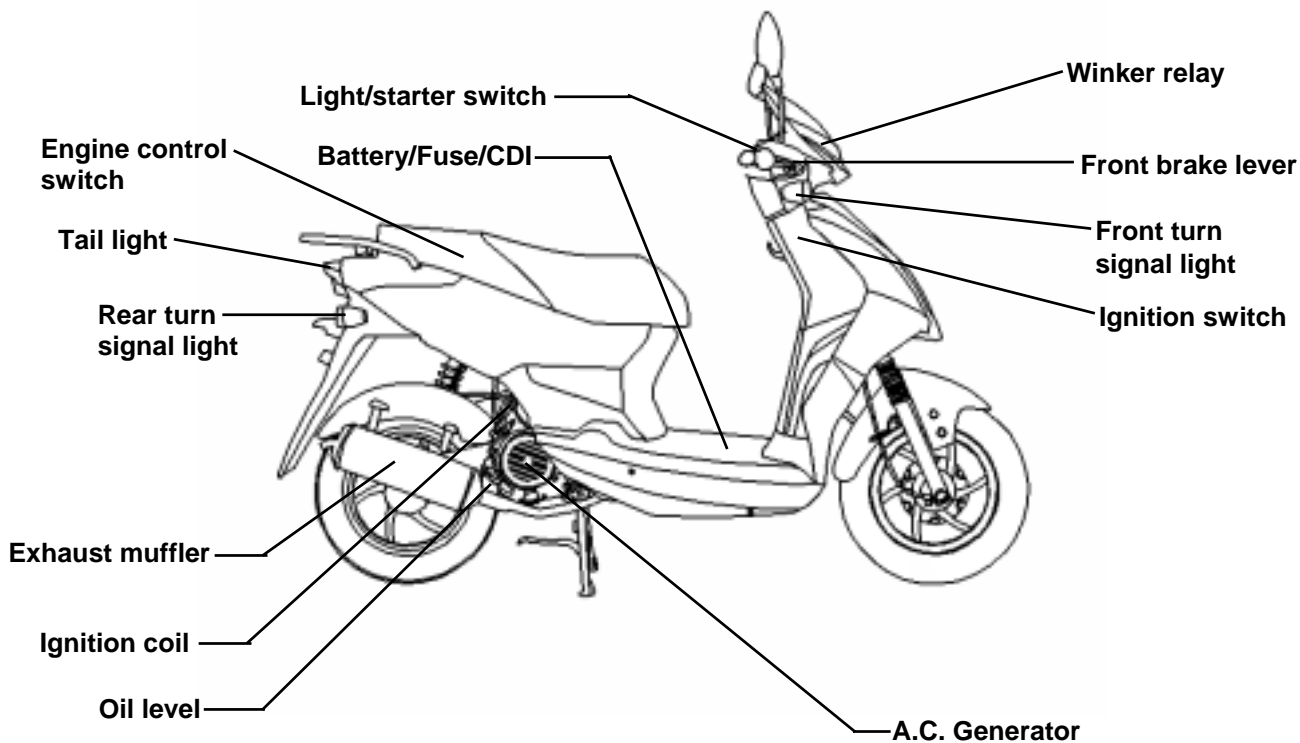
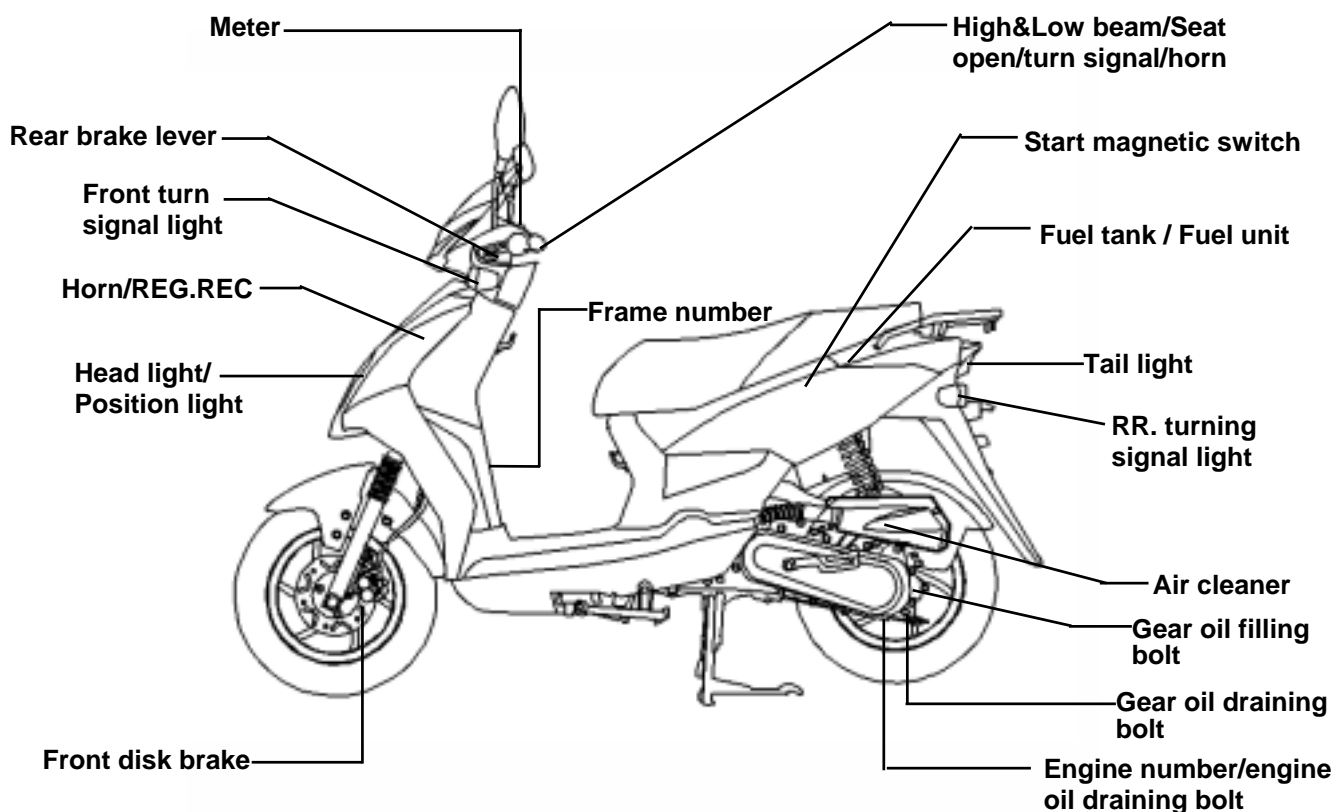









<b>GENERAL INFORMATION/TROUBLE DIAGNOSIS .....</b>	<b>1</b>
<b>MAINTENANCE INFORMATION .....</b>	<b>2</b>
<b>LUBRICATION SYSTEM.....</b>	<b>3</b>
<b>FUEL SYSTEM .....</b>	<b>4</b>
<b>ENGINE REMOVAL.....</b>	<b>5</b>
<b>CYLINDER HEAD/VALVE.....</b>	<b>6</b>
<b>CYLINDER/PISTON.....</b>	<b>7</b>
<b>"V" TYPE BELT DRIVING SYSTEM/KICK STARTER ARM .....</b>	<b>8</b>
<b>FINAL DRIVING MECHANISM.....</b>	<b>9</b>
<b>A.C. GENERATOR/STARTING CLUTCH .....</b>	<b>10</b>
<b>CRANKCASE/CRANKSHAFT .....</b>	<b>11</b>
<b>BODY COVER .....</b>	<b>12</b>
<b>BRAKE SYSTEM.....</b>	<b>13</b>
<b>STEERING/FRONT WHEEL/FRONT SHOCK ABSORBER .....</b>	<b>14</b>
<b>REAR WHEEL/SUSPENSION.....</b>	<b>15</b>
<b>ELECTRICAL EQUIPMENT .....</b>	<b>16</b>
<b>ELECTRICAL DIAGRAM .....</b>	<b>17</b>



SYMBOLS AND MARKS ..... 1-1	TORQUE VALUES (ENGINE) ..... 1-10
GENERAL SAFETY ..... 1-2	TORQUE VALUES (FRAME) ..... 1-11
SERVICE PRECAUTIONS ..... 1-3	TROUBLES DIAGNOSIS ..... 1-12
SPECIFICATIONS ..... 1-9	LUBRICATION POINTS ..... 1-16

**SYMBOLS AND MARKS**

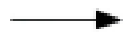
Symbols and marks are used in this manual to indicate what and where the special service are needed, in case supplemental information is procedures needed for these symbols and marks, explanations will be added to the text instead of using the symbols or marks.

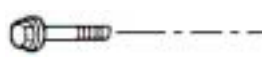
 <b>Warning</b>	Means that serious injury or even death may result if procedures are not followed.
 <b>Caution</b>	Means that equipment damages may result if procedures are not followed.
 <b>Engine oil</b>	Limits to use SAE 10W-30 API SH/CD class oil. Warranty will not cover the damage that caused by not apply with the limited engine oil.
 <b>Grease</b>	King Mate G-3 is recommended.
 <b>Locking sealant</b>	Apply sealant, medium strength sealant should be used unless otherwise specified.
 <b>Oil seal</b>	Apply with lubricant.
 <b>Renew</b>	Replace with a new part before installation.
 <b>Brake fluid</b>	Use recommended brake fluid DOT3 or WELLRUN brake fluid.
 <b>Special tools</b>	Special service tools.
 <b>Correct</b>	Meaning correct installation.
 <b>Wrong</b>	Meaning wrong installation.
 <b>Indication</b>	Indication of components.
 <b>Directions</b>	Indicates position and operation directions.
	Components assembly directions each other.
	Indicates where the bolt installation direction, --- means that bolt cross through the component (invisibility).

## GENERAL SAFETY

### Carbon monoxide

If you must run your engine, ensure the place is well ventilated. Never run your engine in a closed area. Run your engine in an open area, if you have to run your engine in a closed area, be sure to use an extractor.

 **Caution**

Exhaust contains toxic gas which may cause one to lose consciousness and even result in death.

### Gasoline

Gasoline is a low ignition point and explosive material. Work in a well-ventilated place, no flame or spark should be allowed in the work place or where gasoline is being stored.

 **Caution**

Gasoline is highly flammable, and may explode under some conditions, keep it away from children.

### Used engine oil

 **Caution**

Prolonged contact with used engine oil (or transmission oil) may cause skin cancer although it might not be verdict.

### Hot components

 **Caution**

Components of the engine and exhaust system can become extremely hot after engine running. They remain very hot even after the engine has been stopped for some time. When performing service work on these parts, wear insulated gloves and wait until cooling off.

### Battery

 **Caution**

- Battery emits explosive gases; flame is strictly prohibited. Keep the place well ventilated when charging the battery.
- Battery contains sulfuric acid (electrolyte) which can cause serious burns so be careful do not be spray on your eyes or skin. If you get battery acid on your skin, flush it off immediately with water. If you get battery acid in your eyes, flush it off immediately with water, then go to hospital to see an ophthalmologist.
- If you swallow it by mistake, drink a lot of water or milk, and take some laxative such as castor oil or vegetable oil, and then go to see a doctor.
- Keep electrolyte beyond reach of children.

### Brake shoe

Do not use an compressed air or a dry brush to clean components of the brake system, use a vacuum cleaner or the equivalent to avoid asbestos dust flying.

 **Caution**

Inhaling asbestos dust may cause disorders and cancer of the breathing system.

### Brake fluid

 **Caution**

Spilling brake fluid on painted, plastic, or rubber parts may cause damage to the parts. Place a clean towel on the above-mentioned parts for protection when servicing the brake system. Keep brake fluid beyond reach of children.

**SERVICE PRECAUTIONS**

- Always use with SANYANG genuine parts and recommended oils. Using non-designed parts for SANYANG motorcycle may damage the motorcycle.



- Special tools are designed for remove and install of components without damaging the parts being worked on. Using wrong tools may result in parts damaged.

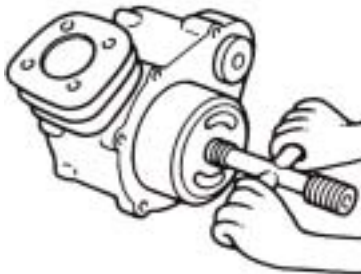

- When servicing this motorcycle, use only metric tools. Metric bolts, nuts, and screws are not interchangeable with the English system, using wrong tools and fasteners may damage this vehicle.
- Clean the outside of the parts or the cover before removing it from the motorcycle. Otherwise, dirt and deposit accumulated on the part's surface may fall into the engine, chassis, or brake system to cause a damage.
- Wash and clean parts with high ignition point solvent, and blow dry with compressed air. Pay special attention to O-rings or oil seals because most cleaning agents have an adverse effect on them.

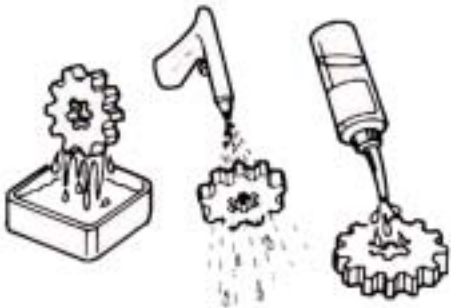

- Never bend or twist a control cable to prevent stiff control and premature worn out.



- Rubber parts may become deteriorated when old, and prone to be damaged by solvent and oil. Check these parts before installation to make sure that they are in good condition, replace if necessary.
- When loosening a component which has different sized fasteners, operate with a diagonal pattern and work from inside out. Loosen the small fasteners first. If the bigger ones are loosen first, small fasteners may receive too much stress.
- Store complex components such as transmission parts in the proper assemble order and tie them together with a wire for ease of installation later.

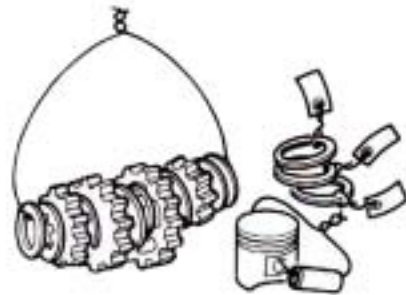

- Note the reassemble position of the important components before disassembling them to ensure they will be reassembled in correct dimensions (depth, distance or position).
- Components not to be reused should be replaced when disassembled including gaskets metal seal rings, O-rings, oil seals, snap rings, and split pins.





- The length of bolts and screws for assemblies, cover plates or boxes is different from one another, be sure they are correctly installed. In case of confusion, Insert the bolt into the hole to compare its length with other bolts, if its length out side the hole is the same with other bolts, it is a correct bolt. Bolts for the same assembly should have the same length.

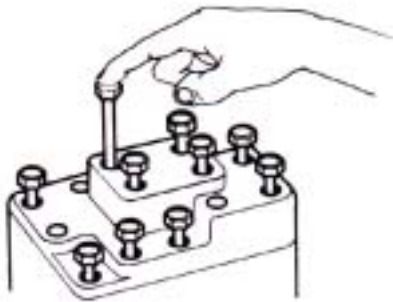

- Tighten assemblies with different dimension fasteners as follows:
- Tighten all the fasteners with fingers, then tighten the big ones with special tool first diagonally from inside toward outside, important components should be tightened 2 to 3 times with appropriate increments to avoid warp unless otherwise indicated. Bolts and fasteners should be kept clean and dry. Do not apply oil to the threads.

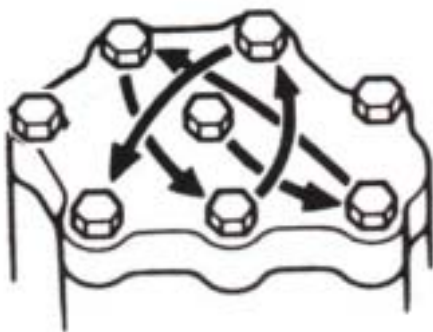

- When oil seal is installed, fill the groove with grease, install the oil seal with the name of the manufacturer facing outside, check the shaft on which the oil seal is to be installed for smoothness and for burrs that may damage the oil seal.

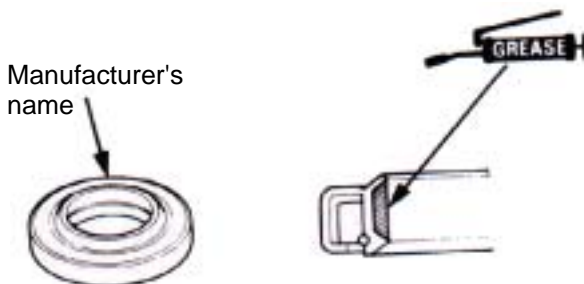

- Remove residues of the old gasket or sealant before reinstallation, grind with a grindstone if the contact surface has any damage.



- The ends of rubber hoses (for fuel, vacuum, or coolant) should be pushed as far as they can go to their connections so that there is enough room below the enlarged ends for tightening the clamps.

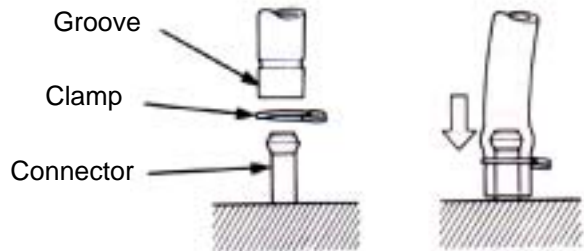

- Rubber and plastic boots should be properly reinstalled to the original correct positions as designed.

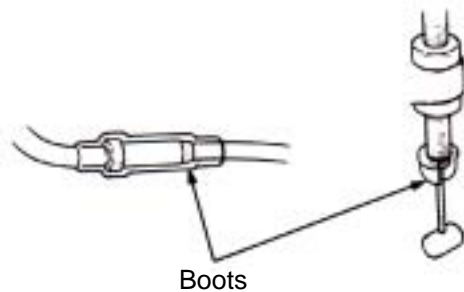

- The tool should be pressed against two (inner and outer) bearing races when removing a ball bearing. Damage may result if the tool is pressed against only one race (either inner race or outer race). In this case, the bearing should be replaced. To avoid damaging the bearing, use equal force on both races.

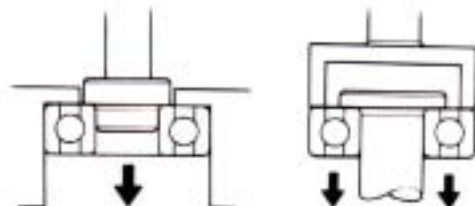

Both of these examples can result in bearing damage.

- Lubricate the rotation face with specified lubricant on the lubrication points before assembling.

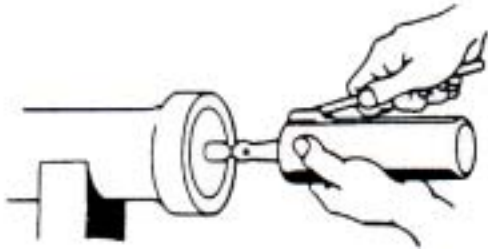

- Check if positions and operation for installed parts is in correct and properly.

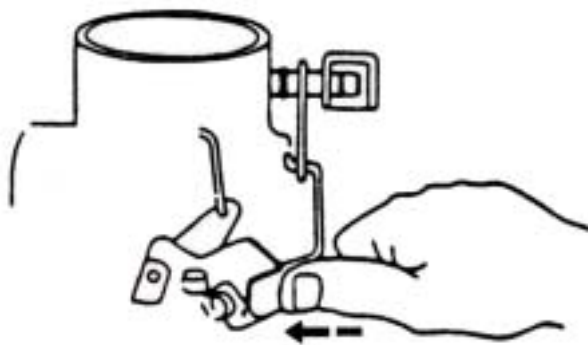

- Make sure service safety each other when conducting by two persons.



- Note that do not let parts fall down



- Before battery removal operation, it has to remove the battery negative (-) cable firstly. Notre tools like open-end wrench do not contact with body to prevent from circuit short and create spark.

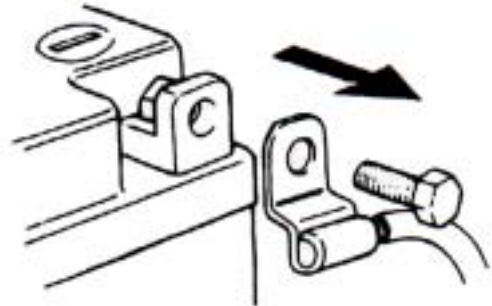

- After service completed, make sure all connection points is secured. Battery positive (+) cable should be connected firstly. And the two posts of battery have to be greased after connected the cables.



- Make sure that the battery post caps are located in properly after the battery posts had been serviced.

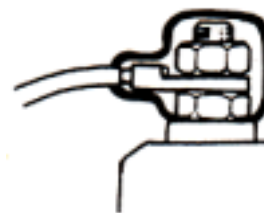

- If fuse burned, it has to find out the cause and solved it. And then replace with specified capacity fuse.

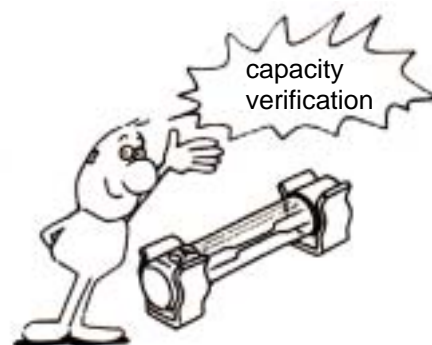

- When separating a connector, it locker has to be unlocked firstly. Then, conduct the service operation.

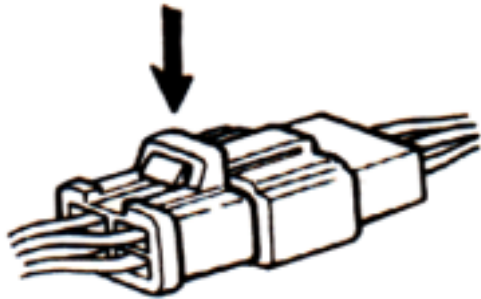

- Do not pull the wires as removing a connector or wires. Hold the connector body.



- Make sure if the connector pins are bent, extruded or loosen.

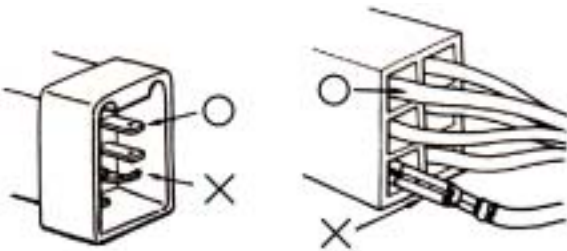

- Insert the connector completely. If there are two lockers on two connector sides, make sure the lockers are locked in properly. Check if any wire loose.

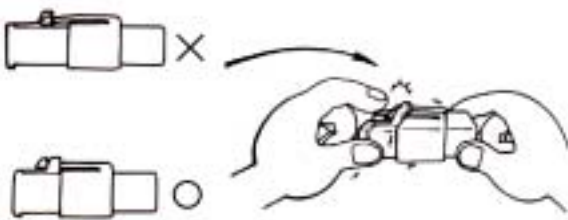

- Check if the connector is covered by the twin connector boot completely and secured properly.

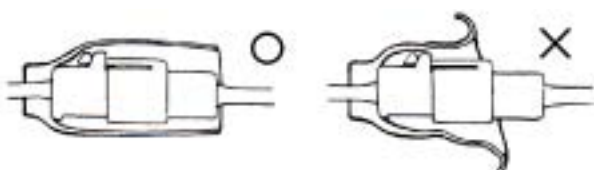

- Before terminal connection, check if the boot is crack or the terminal is loose.



- Insert the terminal completely. Check if the terminal is covered by the boot. Do not let boot open facing up.

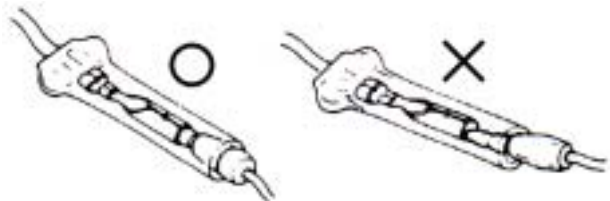

- Secure wires and wire harnesses to the frame with respective wire bands at the designated locations. Tighten the bands so that only the insulated surfaces contact the wires or wire harnesses.

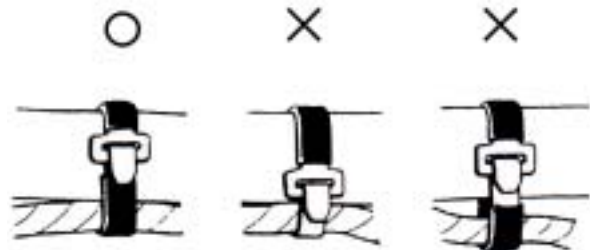

- Wire band and wire harness have to be clamped secured properly.

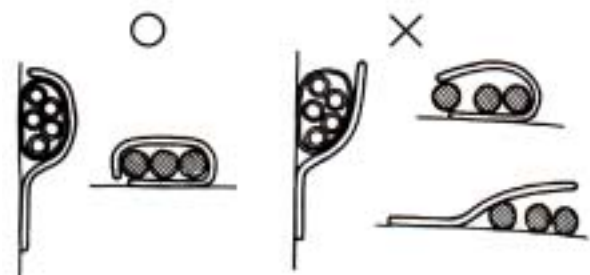

- Do not squeeze wires against the weld or its clamp.



- Do not let the wire harness contact with rotating, moving or vibrating components as routing the harness.

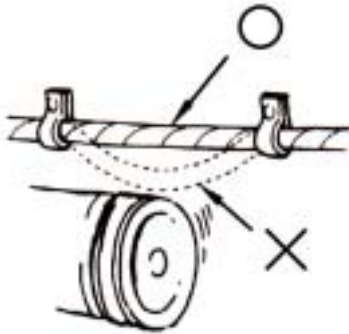

- Protect wires or wire harnesses with electrical tape or tube if they contact a sharp edge or corner. Thoroughly clean the surface where tape is to be applied.

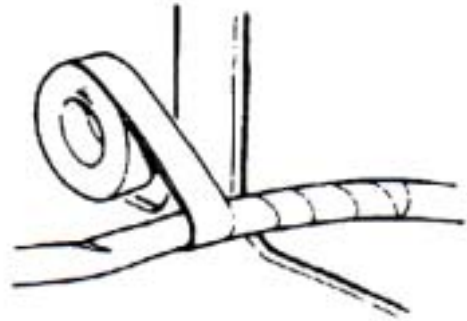

- Keep wire harnesses far away from the hot parts.

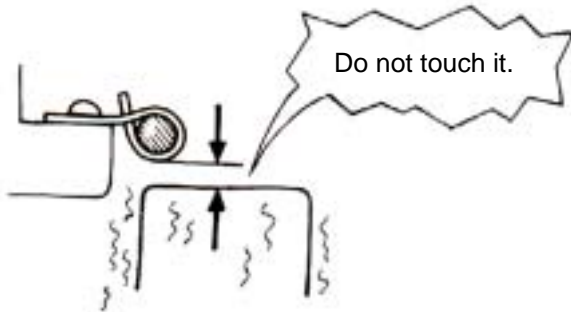

- Secure the rubber boot firmly as applying it on wire harness.

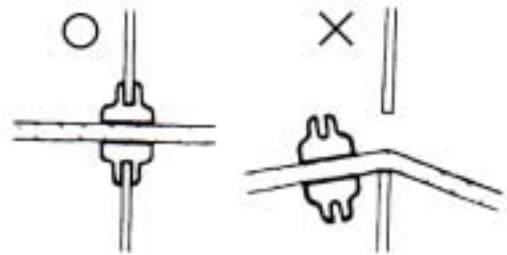

- Route wire harness to avoid sharp edges or corners and also avoid the projected ends of bolts and screws.

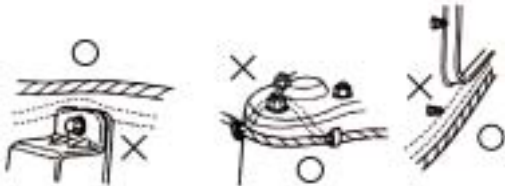

- Never use wires or harnesses which insulation has been broken. Wrap electrical tape around the damaged parts or replace them.

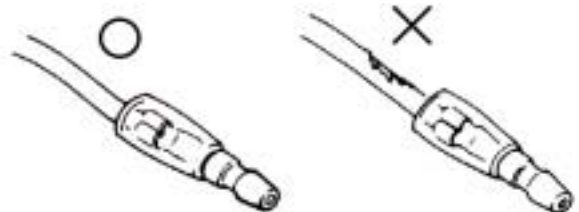

- Route harnesses so that they neither pull too tight nor have excessive slack.

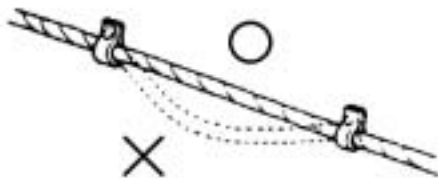

Do not extend it too much.



- Never clamp or squeeze the wire harness as installing other components.

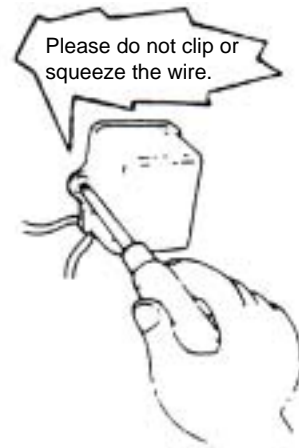

- Do not let the wire harness been twisted as installation.

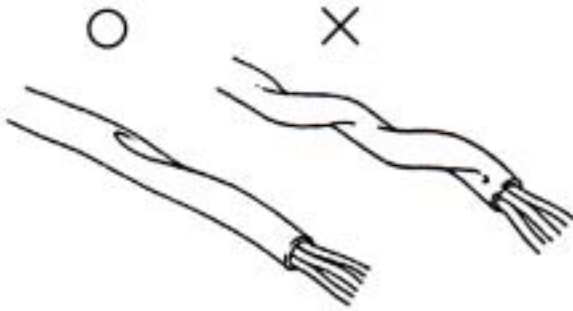

- With sand paper to clean rust on connector pins/terminals if found. And then conduct connection operation later.



- Wire harnesses routed along the handlebar should not be pulled too tight or have excessive slack, be rubbed against or interfere with adjacent or surrounding parts in all steering positions.

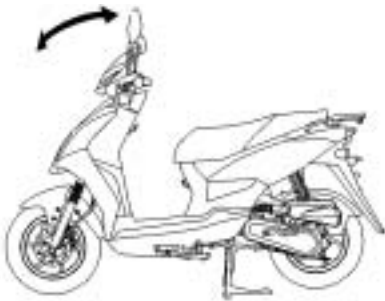

- Before operating a test instrument, operator should read the operation manual of the instrument. And then, conduct test in accordance with the instruction.

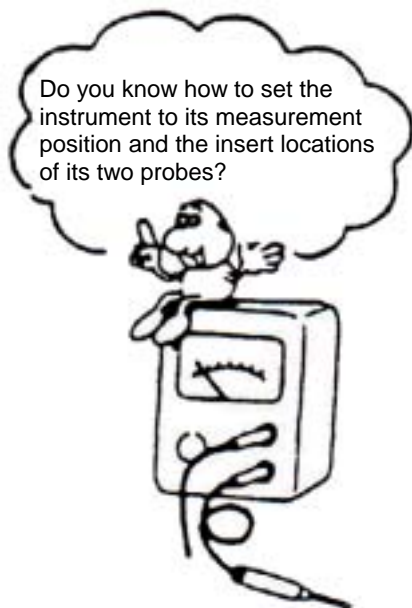

## SPECIFICATIONS

MAKER		SANYANG		MODEL		AAA			
DIMENSION	Overall Length	1905mm		Suspension System	Front	TELESCOPIC FORK			
	Overall Width	690 mm			Rear	SINGLE SWING ARM			
	Overall Height	1238 mm		Tire Specifications	Front	120/70-12 56J			
	Wheel Base	1325mm			Rear	130/70-12 56J			
WEIGHT	Curb Weight	Front	41kg		Brake System	Front	DISK (∅ 190 mm)		
		Rear	68kg						
		Total	109kg			Rear	DRUM (∅ 130 mm)		
	Passengers/Weight		Two men/150 kg		Performance	Max. Speed		91km/hr Above	
	Total Weight	Front	91kg			Climb Ability		28° Below	
		Rear	168kg		Deceleration equipment	Primary Reduction		BELT	
Total		259kg		Secondary Reduction		GEAR			
ENGINE	Type		4-STROKE ENGINE		Deceleration equipment	Clutch		Centrifugal, dry type	
	Installation and arrangement		Vertical, below center, incline 80°			Transmission		C.V.T.	
	Fuel Used		Unleaded (92/95)		Speedometer		0 ~ 140 km/hr		
	Cycle/Cooling		4-stroke/forced air cooled		Horn		95~115dB(A)		
	Cylinder	Bore	39.0 mm		Muffler		Expansion & Pulse Type		
		Stroke	41.5 mm		Exhaust Pipe Position and Direction		Right side, and Backward		
		Number/Arrangement	Single Cylinder/horizontal		Lubrication System		forced-circulation&splashing		
	Displacement		49.6 cc		Exhaust Concentration	Solid Particulate		15 % ↓	
	Compression Ratio		11.8 ± 0.1			CO		1.5 % ↓	
	Max. HP		2.35KW/ 7500 rpm			HC(Europe )		Below900 PPM	
	Max. Torque		2.96N.m /6500 rpm						
	Ignition		C.D.I.						
Starting System		Electrical & foot type							

## TORQUE VALUES (ENGINE)

ITEM	Q'TY	THREAD DIA (mm)	TORQUE VALUE(Kg-m)	REMARKS
Cylinder head bolts	4	6	1.0~1.4	
Cylinder head nuts	4	8	1.8~2.2	Apply oil to thread
Cylinder/cylinder head two-ends bolts	4	8	0.7~1.0	Tighten to crankcase
Cylinder head left bolts	4	6	1.0~1.4	
Valve adjustment fixing nuts	4	5	0.7~1.1	Apply oil to thread
Spark plug	1	10	1.0~1.4	
Carburetor heat protector connecting nuts	2	6	0.7~1.1	
Engine oil draining plug	1	12	3.5~4.5	
Engine oil strainer cap	1	30	1.3~1.7	
Gear oil draining plug	1	10	1.0~1.4	
Gear oil filling bolt	1	10	1.0~1.4	
Oil pump screws	3	3	0.1~0.3	
Engine left side cover bolts	7	6	1.0~1.5	Rubber washer attached
Camshaft chain tensioner bolt	1	6	0.8~1.2	Hex socket bolt
Camshaft chain adjuster bolts	2	6	1.0~1.4	
Clutch driving plate nut	1	28	5.0~6.0	
Clutch outer bracket nut	1	12	5.0~6.0	
Driving disk nut	1	12	5.0~6.0	
Flywheel nut	1	12	5.0~6.0	
One-way clutch tighten bolts	3	6	1.0~1.4	Apply locking sealant
One-way clutch nut	1	22	9.0~10.0	Apply oil to thread
Crankcase bolts	7	8	1.5~2.0	
Gear box cap bolts	7	8	2.0~2.4	
Exhaust pipe bolts	2	8	3.0~3.6	
Exhaust pipe connecting nuts	2	6	1.0~1.4	

**TORQUE VALUES (FRAME)**

ITEM	Q'TY	THREAD DIA (mm)	TORQUE VALUE(Kg-m)	REMARKS
Mounting bolt for steering handlebar	1	10	4.0~5.0	
Mounting nut for steering rod	1	25.4	1.0~2.0	
Cone seat for steering rod	1	25.4	0.2~0.3	
Front wheel shaft nut	1	12	5.0~7.0	
Rear wheel shaft nut	1	16	11.0~13.0	
Wheel hub/rim mounting nuts	8	8	2.8~3.2	
Speedometer cable locking screw	1	5	0.15~0.3	
Front shock absorber mounting bolts	4	8	2.4~3.0	
Rear shock absorber upper connection bolt	1	10	3.5~4.5	
Rear shock absorber upper connection bolt	1	8	2.4~3.0	
Brake lever bolts	2	6	0.8~1.2	
Front brake hose bolts	2	10	3.3~3.7	
Front brake air-bleeding valve	1	6	0.8~1.0	
Front brake disc mounting bolts	4	10	4.0~4.5	
Front brake clipper mounting bolts	2	10	3.1~3.5	
Drum brake arm bolts (front/rear)	2	6	0.8~1.2	
Engine suspension bracket bolts	2	10	4.5~5.5	On frame side
Engine connection bolt	1	10	4.5~5.5	On engine side
Main standard nut	1	10	3.5~4.5	
Foot-starting lever bolt	1	6	1.6~1.8	
Air cleaner bolts	2	6	1.0~1.4	

The torque values listed in above table are for more important tighten torque values. Please see standard values for not listed in the table.

**Standard Torque Values for Reference**

TYPE	TIGHTEN TORQUE	TYPE	TIGHTEN TORQUE
5mm bolt, nut	0.45~0.60kgf-m	3mm screw	0.05~0.08kgf-m
6mm bolt, nut	0.80~1.20kgf-m	4mm screw	0.10~0.15kgf-m
8mm bolt, nut	1.80~2.50kgf-m	5mm screw	0.35~0.50kgf-m
10mm bolt, nut	3.00~4.00kgf-m	6mm screw, SH nut	0.70~1.10kgf-m
12mm bolt, nut	5.00~6.00kgf-m	6mm bolt, nut	1.00~1.40kgf-m
		8mm bolt, nut	2.40~3.00kgf-m
		10mm bolt, nut	3.50~4.50kgf-m



**TROUBLES DIAGNOSIS**

**A. Engine hard to start or can not be started**

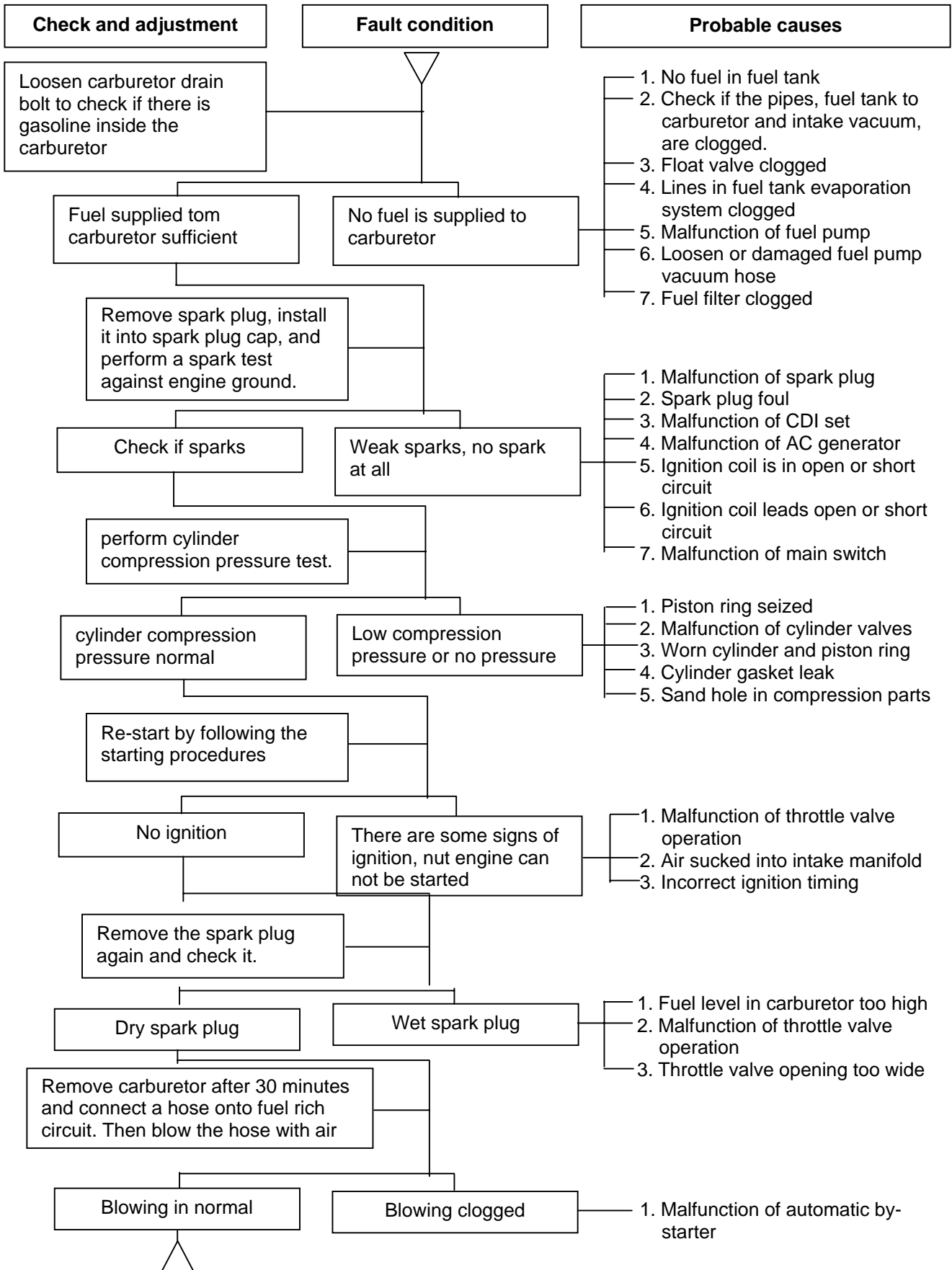

**B. Engine run sluggish (Speed does not pick up, lack of power)**

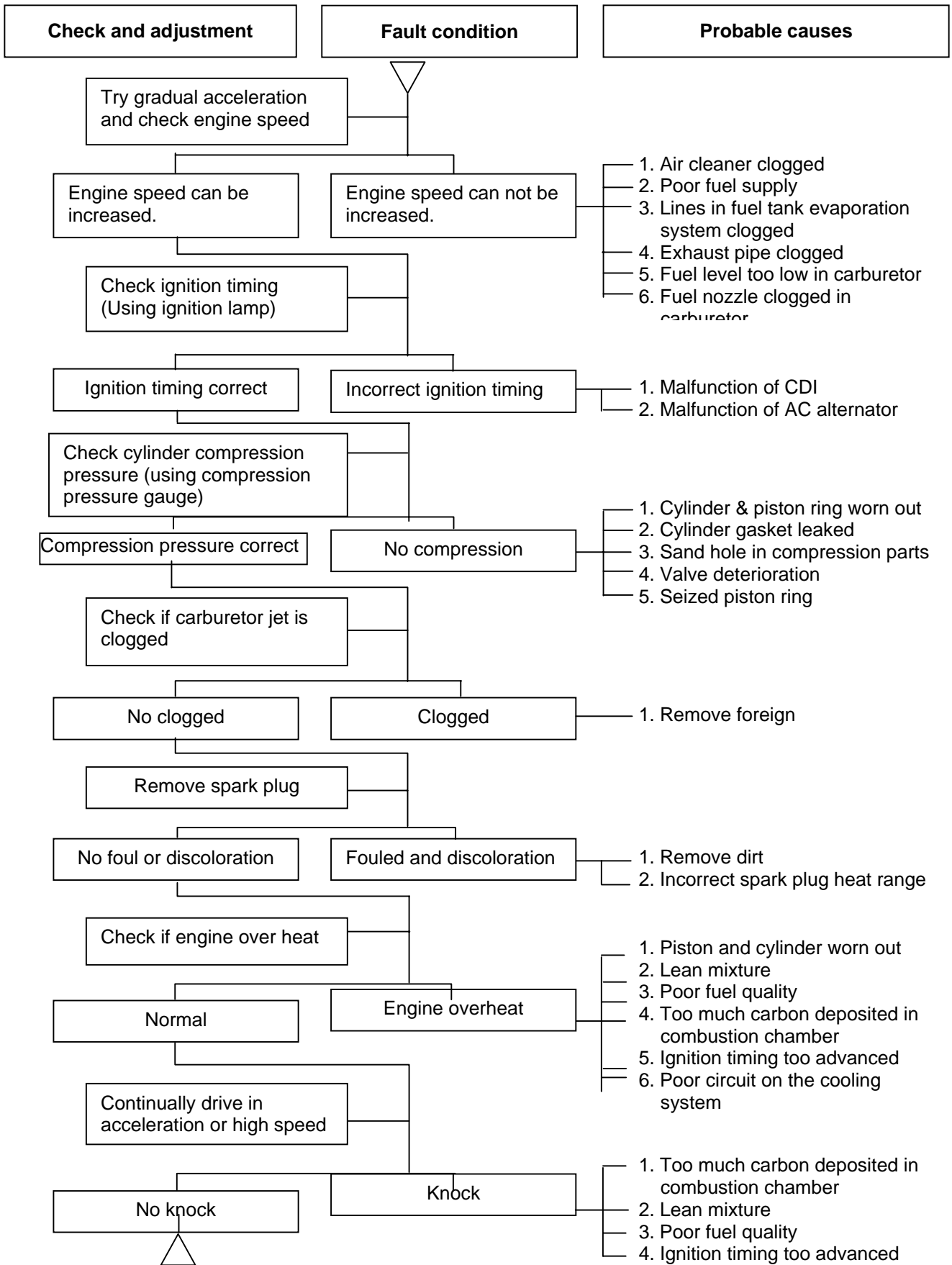

C. Engine runs sluggish (especially in low speed and idling)

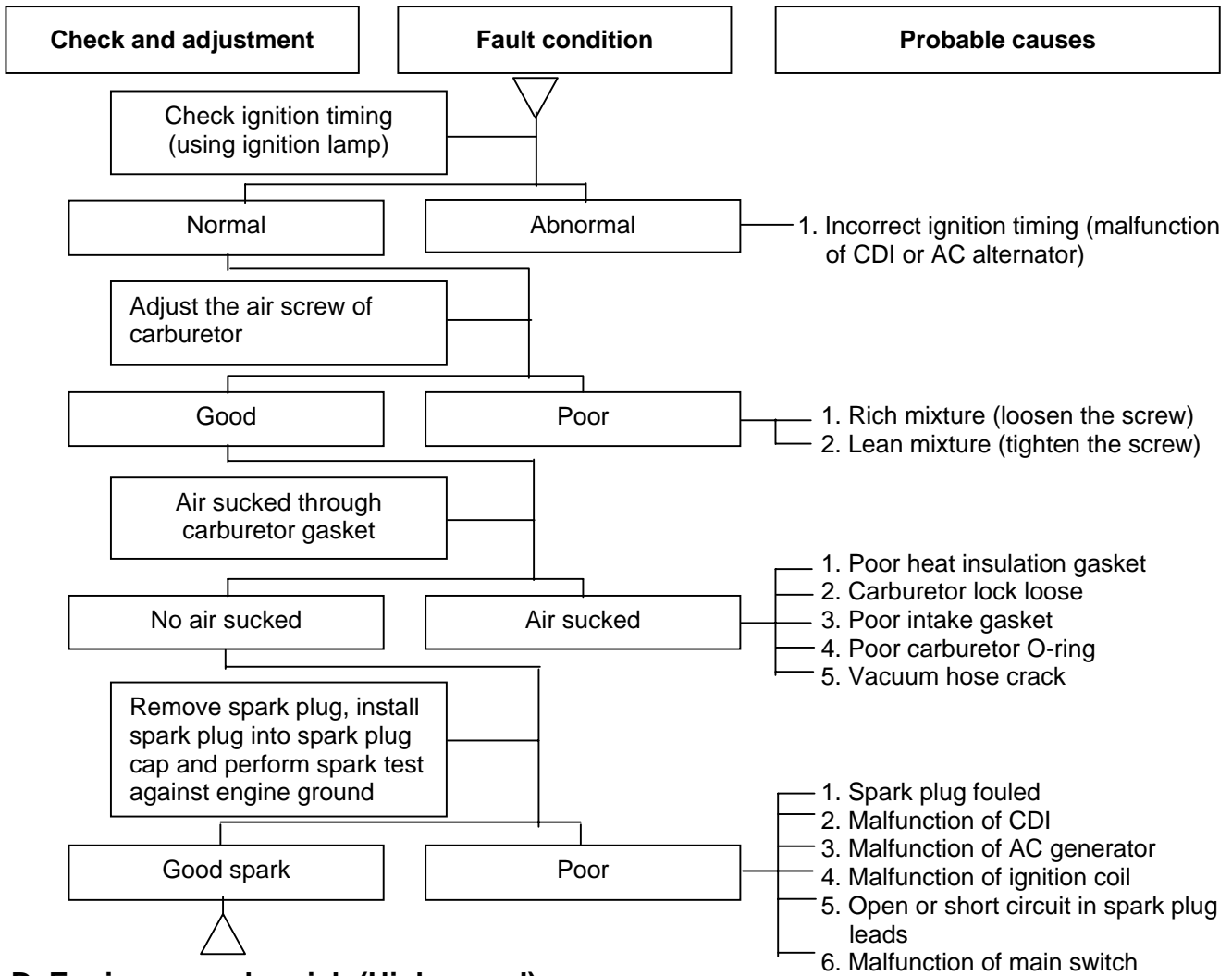

D. Engine runs sluggish (High speed)

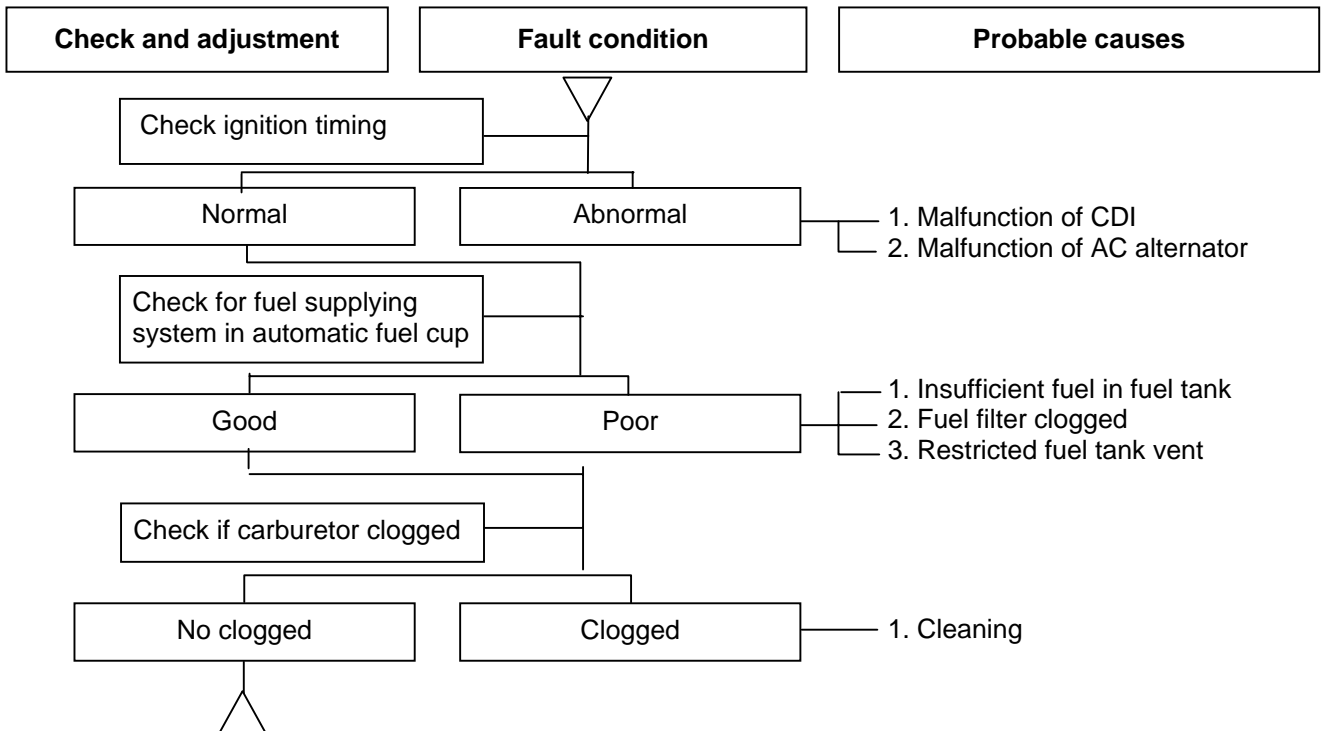

**E. CLUTCH, DRIVING AND DRIVING PULLEY**

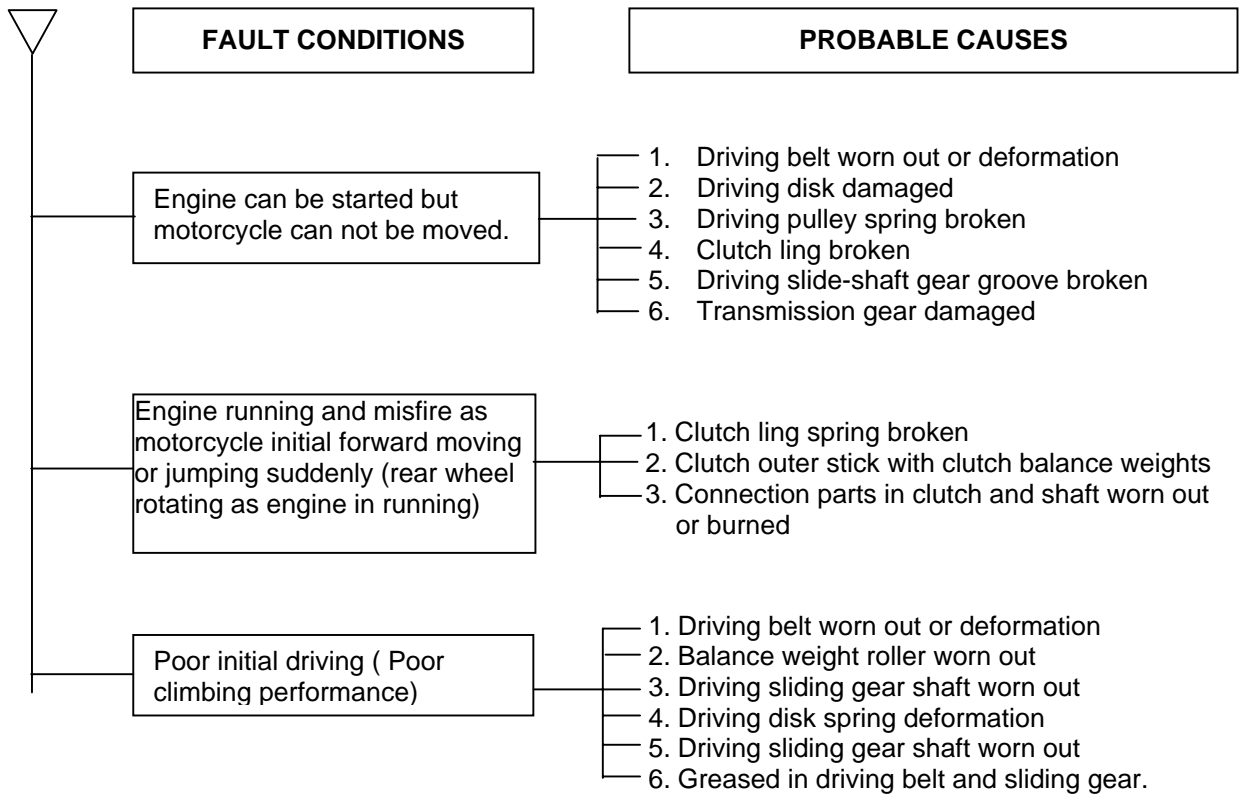

LUBRICATION POINTS

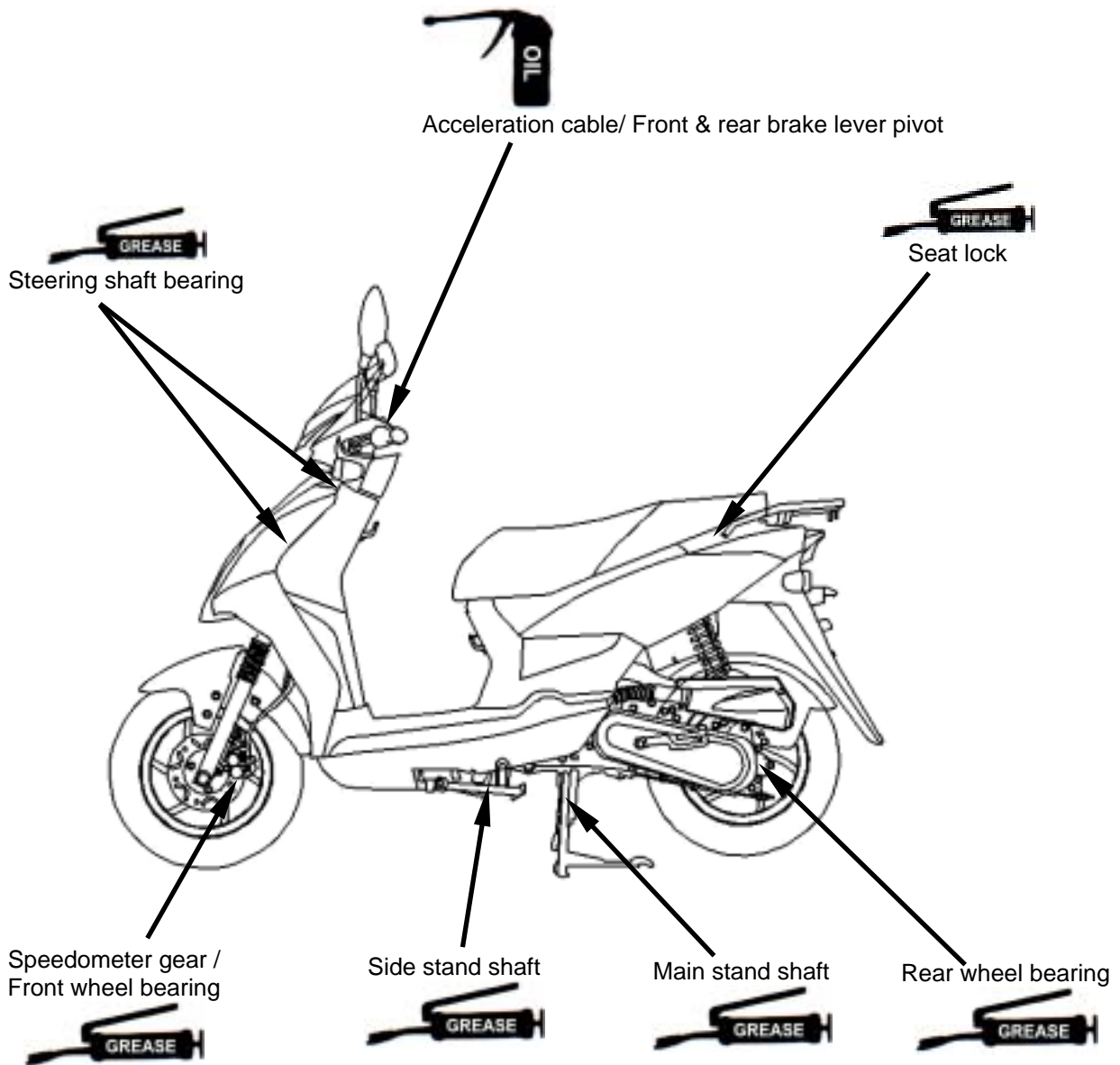

PRECAUTIONS IN OPERATION .....2-1	DRIVING SYSTEM.....2-9
PERIODICAL MAINTENANCE SCHEDULE.....2-2	STEERING SYSTEM .....2-10
LUBRICATION SYSTEM.....2-3	SUSPENSION SYSTEM .....2-10
FUEL SYSTEM.....2-4	FRONT DISK BRAKE SYSTEM.....2-11
AIR CLEANER.....2-5	DRUM BRAKE SYSTEM.....2-13
THROTTLE VALVE OPERATION .....2-5	WHEEL/TIRE.....2-14
VALVE CLEARANCE INSPECTION & ADJUSTMENT .....2-6	BATTERY .....2-15
CARBURETOR IDLING SPEED ADJUSTMENT ..2-7	HEADLIGHT ADJUSTMENT .....2-15
IGNITION SYSTEM/SPARK PLUG ..2-8	NUTS、BOLTS TIGHTEN.....2-15
CYLINDER COMPRESSION PRESSURE ..2-9	

**PRECAUTIONS IN OPERATION**

**Specification**

Fuel Tank Capacity	Main	5200 c.c.
	auxiliary	1500 c.c.
Engine Oil	capacity	850 c.c.
	change	750 c.c.
Transmission Gear oil	capacity	120 c.c.
	change	110 c.c.
Clearance of throttle valve		2~6 mm
Spark plug		TORCH A7RC Gap: 0.6~0.7 mm
“F” Mark in idling speed		Before TDC 13° / 2200 rpm
Full timing advanced		Before TDC 26° / 8000 rpm
Idling speed		2200±100 rpm
Cylinder compression pressure		12±2 kg/cm <sup>2</sup>
Valve clearance: IN/EX		0.06±0.02 mm
Tire dimension	front / rear	120/70-12 56J / 130/70-12 56J
Tire pressure (cold)	single	Front: 1.75 kg/cm <sup>2</sup> rear: 2.00 kg/cm <sup>2</sup>
	Two persons	Front: 1.75 kg/cm <sup>2</sup> rear: 2.25 kg/cm <sup>2</sup>
battery		12V6Ah (MF battery)
Play of drum brake lever		10~20 mm

### PERIODICAL MAINTENANCE SCHEDULE

Maintenance Code	Item	Initial 300KM	1 Month Every1000KM	3 month Every3000KM	6 month Every6000KM	1 year Every12000KM
1	Air cleaner	I		C	C	R
2	2nd air jet leaner	I		C	C	R
3	Fuel filter	I			I	R
4	Oil filter	C			C	C
5	Engine oil change	R	Replacement for every 1000km			
6	Tire pressure	I	I			
7	Battery inspection	I	I			
8	Brake & free play check	I	I			
9	Steering handle check	I	I			
10	Cushion operation check	I	I			
11	Every screw tightening check	I	I			
12	Gear oil check for leaking	I	I			
13	Spark plug check or change	I		I	R	
14	Gear oil change	R	Replacement for every 5000km			
15	Frame lubrication				L	
16	Exhaust pipe	I	I			
17	Ignition timing	I	I			
18	Emission check in Idling	A	I			
19	Throttle operation	I		I		
20	Engine bolt tightening	I		I		
21	CVT driving device (belt )				I	R
22	CVT driving device (roller)				C	
23	Lights/electrical equipment/multi-meters	I	I			
24	Main/side stands & springs	I			I	
25	Fuel pipes	I		I		
27	Cam chain	I		I		
28	Valve clearance	I		A		
29	Crankcase vapor control System	I		C		
30	Crankcase blow-by over-flow pipe	I	Replacement for every 2000km			
31	2nd air jet system	I		I	C	
32	vapor control system			I		

**Code: I ~ Inspection, cleaning, and adjustment R ~ Replacement C ~ Cleaning (replaced if necessary) L ~ Lubrication**

Have your motorcycle checked, adjusted, and recorded maintenance data periodically by your SYM Authorized Dealer to maintain the motorcycle at the optimum condition

The above maintenance schedule is established by taking the monthly 1000 kilometers as a reference which ever comes first.

#### Remarks:

1. These marks “ ” in the schedule are emission control items. According to EPA regulations, these items must be perform normally periodical maintenance following the use r manual instructions. They are prohibited to be adjusted or repaired by unauthorized people. Otherwise, SYM is no responsible for the charge.
2. Clean or replace the air cleaner element more often when the motorcycle is operated on dusty roads or in the Heavily- polluted environment.
3. Maintenance should be performed more often if the motorcycle is frequently operated in high speed and after the motorcycle has accumulated a higher mileage.
4. Preventive maintenance
  - a. Ignition system - Perform maintenance and check when continuous abnormal ignition, misfire, after-burn, overheating occur.
  - b. Carbon deposit removal - Remove carbon deposits in cylinder head, piston heads, exhaust system when power is obvious lower than ever.
  - c. Replace worn out pistons, cylinder head.

**LUBRICATION SYSTEM**

**Engine Oil Capacity**

**⚠ Caution**

- The vehicle must be parked on a level ground when checking oil capacity.
- Run the engine for 2-3 minutes then stop, wait about 2-3 more minutes allowing engine oil to settle before checking the oil level.

Remove dipstick to check the oil level. If oil level is below the lower limit mark, add oil to the specified upper limit mark.

**Oil change**

Shut off the engine and remove dipstick.

Remove the oil drain plug on the bottom-left of crankcase to drain oil.

After draining out oil, clean oil plug and its +-gasket and reinstall. Replace the gasket if it is damaged.

**Torque value: 3.5~4.5 kgf-m**

**⚠ Caution**

Warm up the engine. This will make the oil flow out easily.

Add oil to the specified capacity.

Oil Viscosity: SAE 10W-30, recommended using King-Mate serial oil.

**Engine oil capacity:**

**Disassembly: 850cc**

**Change: 750cc**

When checking for oil leak, run the engine at idle speed for a few minutes, then check oil capacity with dipstick.

**Cleaning the oil strainer**

Drain oil from engine, remove the strainer cover, spring and strainer.

If there is an accumulation on the screen, wash it off with suitable solvent (recommended using compressed air). Check O-ring for damage, replace if necessary.

Reinstall strainer, spring, O-ring and strainer cover.

**Torque value: 1.3~1.7 kgf-m**



Dipstick

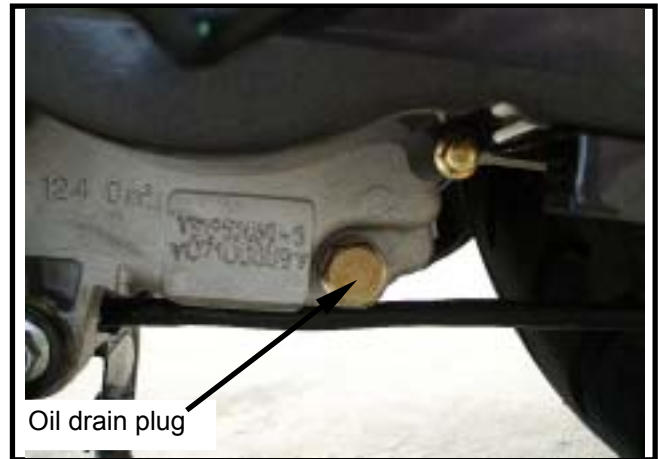

Oil drain plug

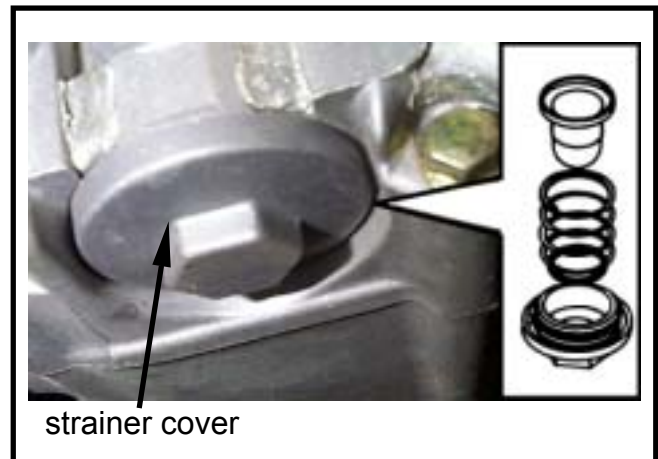

strainer cover

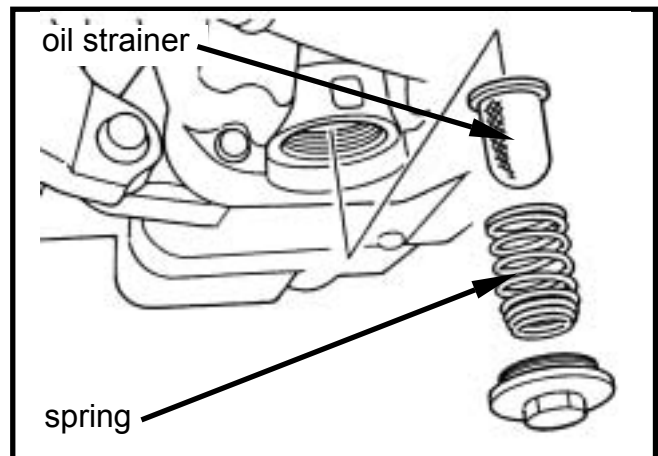

spring



### Gear Oil

#### Inspection

Check gear oil if leaking.  
Park the motorcycle with main stand on flat level place.  
Turn off engine and remove the gear oil draining plug.  
Place a measurement cup under the draining hole.  
Remove the oil drain plug and drain gear oil into a measurement cup.  
Check gear oil if enough.

#### Replacement

At first, remove the gear oil refilling bolt, and then remove the draining plug.  
Install the draining plug after drained oil out.

**Torque value: 0.8~1.2 kgf-m**

#### ⚠ Caution

Inspect if washer is in good condition.  
Replace it with new one if it was deformed or damaged.

Fill out gear oil to specified quantity from the engine oil filling hole.  
Install the oil filling bolt.

**Torque value: 0.8~1.2 kgf-m**

**Quantity: 100 c.c.**

Recommended: King-Mate HYPOID GEAR OIL ( #140 ).



### Fuel System

#### Fuel Pipe

Remove luggage box, rear center cover, body cover, and rear fender, as well as front inner box.  
Check all pipes, and replace it when they are deterioration, damage or leaking.

#### ⚠ Warning

Gasoline is a low ignition material so any kind of fire is strictly prohibited as dealing it.

#### Fuel filter

Remove the fuel tank.  
Remove fuel pipe from the fuel filter.  
Replace the fuel filter with new one.  
Install the fuel filter.

#### ⚠ Caution

The arrow on the fuel filter means the flow direction of fuel and check it if leaking after installation.

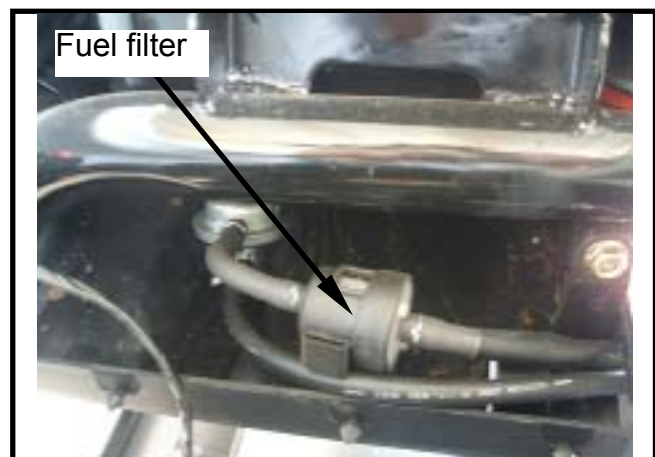

**AIR CLEANER**

**Element**

Remove 7 screws from the air cleaner cover.  
 Remove element of air cleaner (2 screws).  
 Check the element if dirt or damaged.  
 Replace it with new one if dirt or damaged.

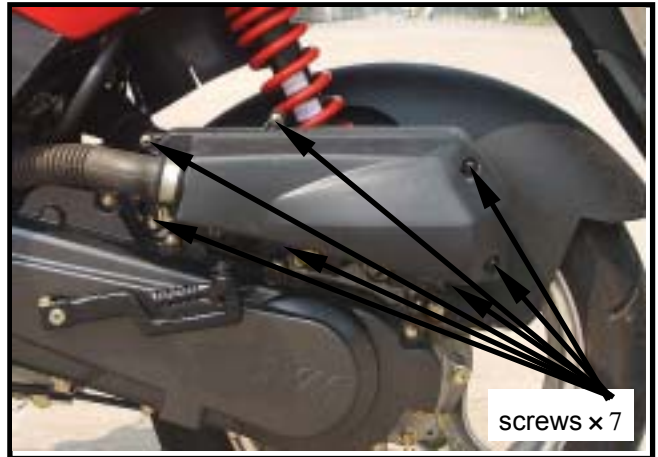

**⚠ Caution**

- Air cleaner element contains a paper made filter so do not try to clean it.
- Make sure that the air cleaner cover had been installed properly after installation.

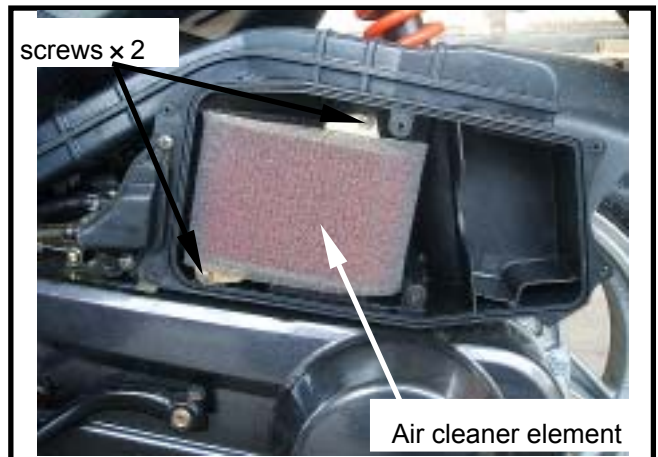

**THROTTLE VALVE OPERATION**

Have a wide open of throttle valve as handle bar in any position and release it to let back original (full closed) position.  
 Check handle bar if its operation is smooth.  
 Check throttle valve cable and replace it if deteriorated, twisted or damaged.  
 Lubricate the cable if operation is not smooth.  
 Measure handle bar free play in its flange part.

**Free play : 2~6 mm**

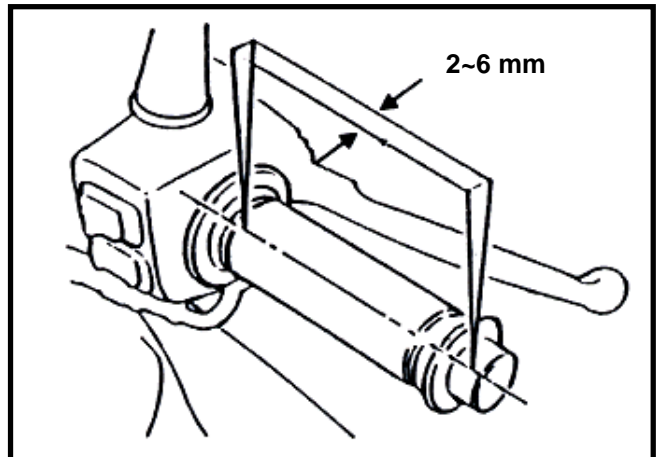

Adjustment can be done in either ends.  
 Secondary adjustment is conducted from top side.  
 Remove rubber boot, loosen fixing nut, and then adjust it by turning the adjustment nut.

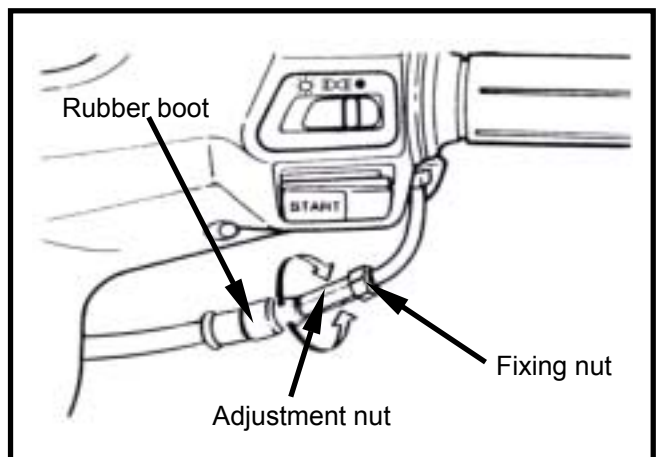

Primary adjustment is conducted from button side.

Loosen fixing nut, and adjust by turning the adjustment nut.

Tighten the fixing nut, and check acceleration operation condition.

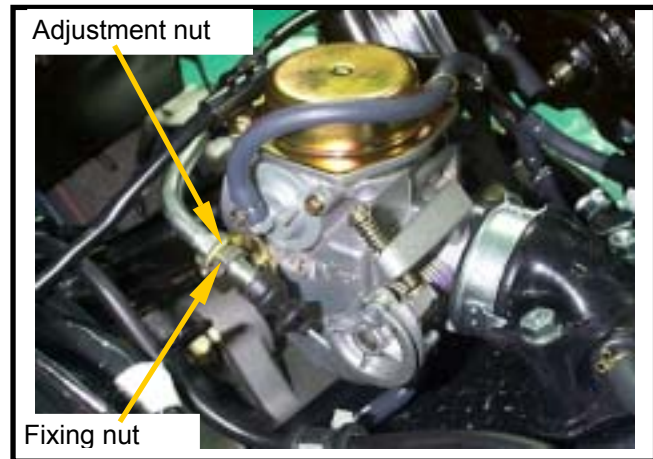

### **Caution**

When always riding in rainy area or full throttle position, maintenance period must be shorted. The deposits can be seen in the transparent section of draining hose.

## VALVE CLEARANCE ADJUSTMENT

### **Caution**

Checks and adjustment must be performed when engine is cold (below 35 °C).

Remove luggage box and front center cover.  
Remove the left body cover & left side cover.  
Remove cylinder head cap.  
Remove the ignition timing check hole on the cooling fan cover.

With "T" type wrench, turn crankshaft in clockwise motion so that mark ("T") on the generator flywheel aligns with the mark on the crankshaft, and camshaft is at TDC position also as same as level of cylinder head top-end. A single hole on camshaft sprocket is forward to up. (Piston is at TDC position in the compression stroke.)

### **Caution**

The crankshaft can not be rotated in counter-clockwise to prevent from damage so that valve clearance can not be measured.

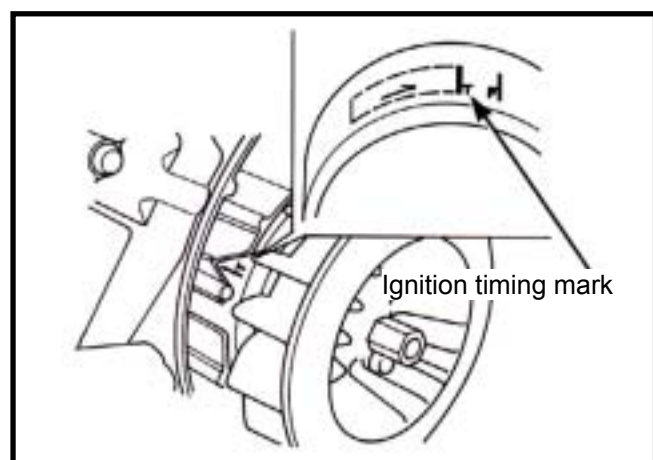
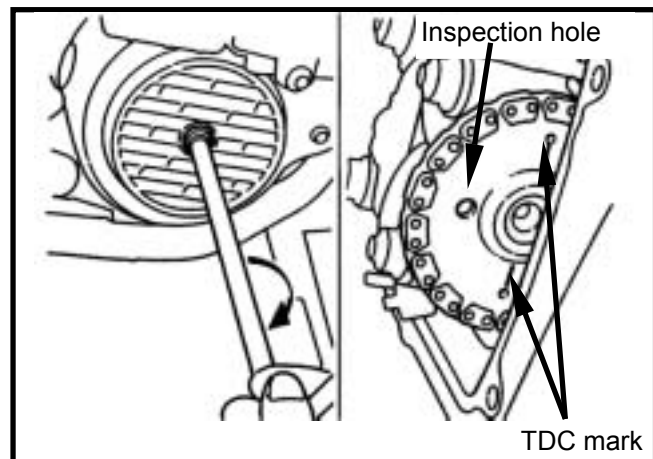

## VALVE CLEARANCE INSPECTION AND ADJUSTMENT

Check & adjust valve clearance with feeler gauge.

**Valve clearance (IN/EX):  $0.12 \pm 0.02$  mm**

Loosen fixing nut and turn the adjustment nut for adjustment.

### Caution

It has to make sure that valve-rocker arm is be adjusted to standard level when adjusting it, and re-check the valve clearance after tightened the fixing nut.

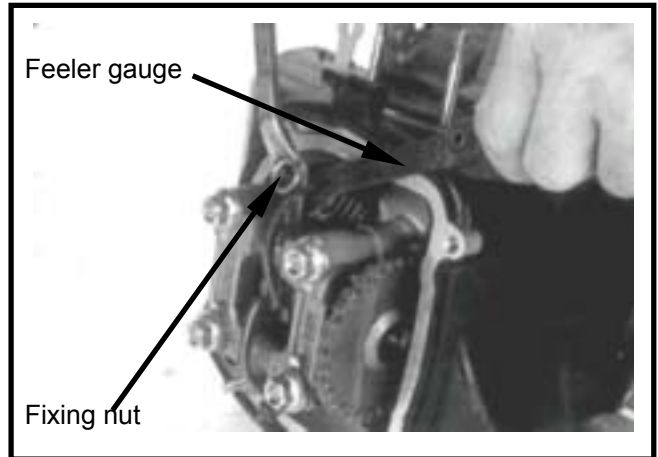

## CARBURETOR IDLE SPEED ADJUSTMENT

### Caution

- Inspection & adjustment for idle speed have to be performed after all other parts in engine that needed adjustment have been adjusted.
- Idle speed check and adjustment have to be done after engine is being warm up (around 10 minutes).

Park the motorcycle with main stand and warm up engine.

Open the carburetor cover from the luggage box.

Turn the throttle valve stopper screw to specified idle speed.

**Specified idle speed:  $1700 \pm 100$  rpm**

### Emission adjustment in Idle speed

Warm up the engine for around 10 minutes and then conduct this adjustment.

1. Connect the tachometer onto engine.
2. Adjust the idle speed adjustment screw and let engine runs in  $1700 \pm 100$  rpm.
3. Insert the exhaust sampling muffler of exhaust analyzer into the front section of exhaust pipe. Adjust the air adjustment screw so that emission value in idle speed is within standard.
4. Slightly accelerate the throttle valve and release it immediately. Repeat this for 2~3 times.
5. Read engine RPM and value on the exhaust analyzer. Repeat step 2 to step 4 procedures until measured value within standard.

**Emission standard: CO: below 4.5%**

**HC: below 9000 ppm**

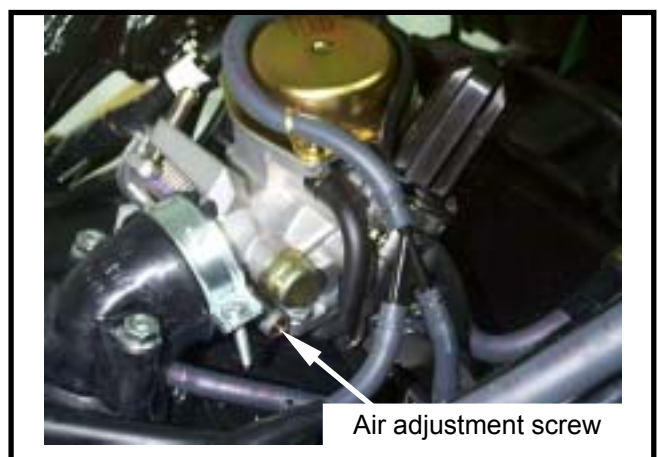
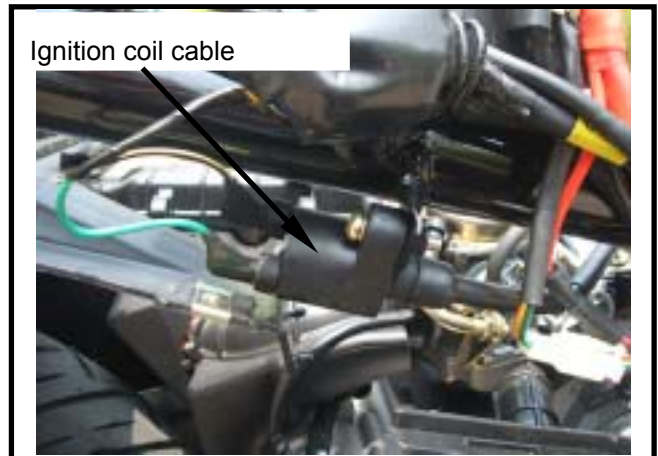

### IGNITION SYSTEM

#### Ignition timing

##### **Caution**

C.D.I ignition system is set by manufacturer so it can not be adjusted.  
Ignition timing check procedure is for checking whether C.D.I. function is in normal or not.

Remove ignition timing hole cap located on the cooling fan cap, or remove the cooling fan cap.

Check ignition timing with ignition light.  
Start engine and set engine idle speed in 1700 rpm, and if the mark aligns with the "F", then it means that ignition timing is correct.  
Increase engine speed to 8000 rpm to check ignition timing advance. If the detent aligns with advance mark "H", then it means ignition timing advance is in functional. If not, check CDI set, pulse flywheel, and pulse generator. Replace these components if malfunction of these parts are found.

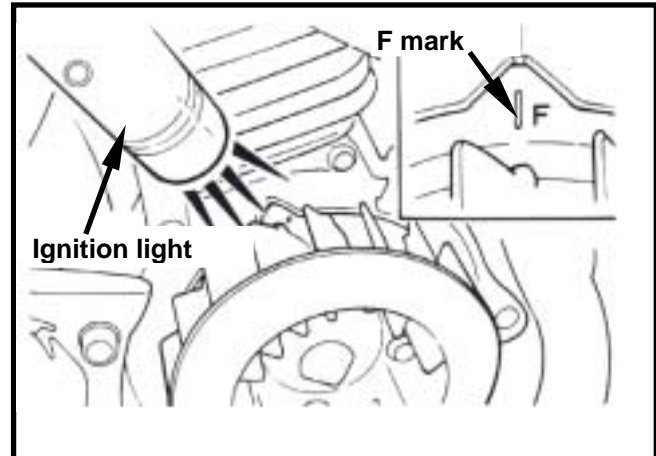

### SPARK PLUG

#### **Appointed spark plug: TORCH A7RC**

Remove luggage box.

Remove center cover.

Remove spark plug cap.

Clean dirt around the spark plug hole.

Remove spark plug.

Measure spark plug gap.

#### **Spark plug gap: 0.6~0.7 mm**

Carefully bend ground electrode of the plug to adjust the gap if necessary.

Screw the park plug into the plug hole with hands, then tighten the plug with a wrench to prevent from damaging the spark plug's thread.

#### **Torque value: 1.0~1.2 kgf-m**

Connect spark plug cap.

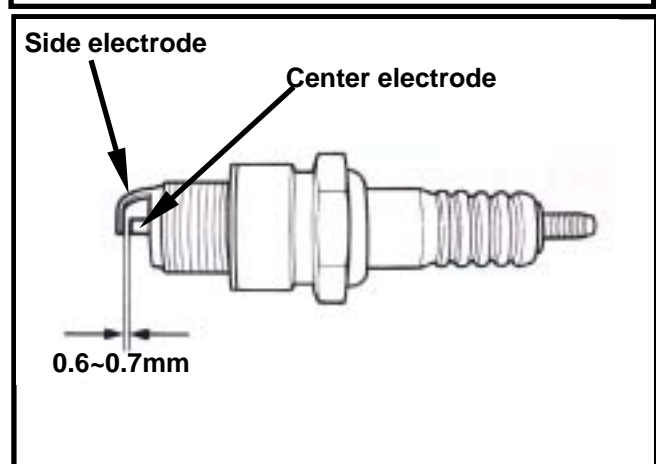

**CYLINDER COPMRESSION PRESSURE**

Warm up engine and then turnoff the engine.  
 Remove the luggage box and the center cover.  
 Remove spark plug cap and spark plug.  
 Install compression gauge.  
 Full open the throttle valve, and rotate the engine by means of stepping the kick-starting lever.

**⚠ Caution**

Rotate the engine until the reading in the gauge no more increasing.  
 Usually, the highest pressure reading will be obtained in 4~7 seconds.

**Compression pressure: 12±2 Kg/cm<sup>2</sup>**

Check following items if the pressure is too low:

- Incorrect valve clearance
- Valve leaking
- Cylinder head leaking, piston, piston ring and cylinder worn out

If the pressure is too high, it means carbon deposits in combustion chamber or piston head.

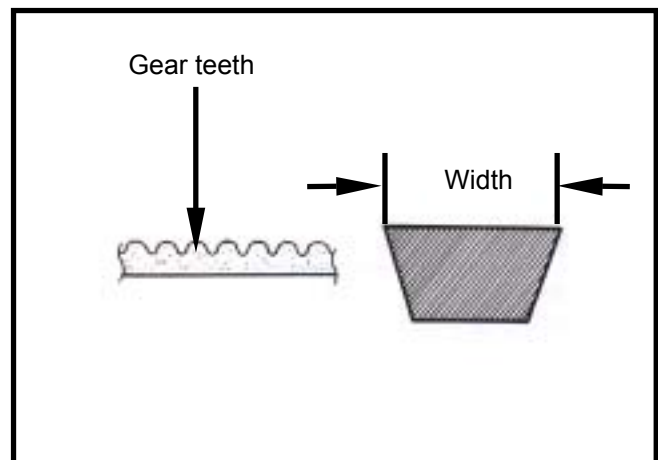
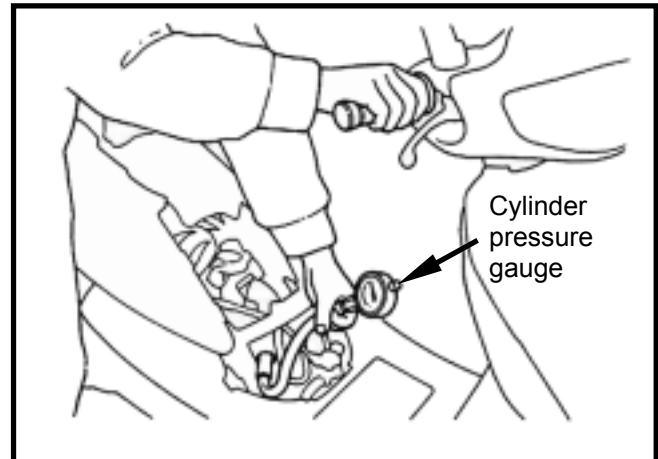

**DRIVING SYSTEM**

**DRIVING BELT**

Remove left side cover.  
 Remove mounting bolt located under air cleaner.  
 Remove 9 bolts of the engine left crankcase.  
 Remove the left crankcase cover.  
 Check if the belt is crack or worn out.  
 Replace the belt if necessary or in accord with the periodical maintenance schedule to replace it.

**Width limit: above 18.5 mm**

**Clutch pad**

Start the motorcycle and gradually increase throttle valve openness to check clutch pad operation.  
 If the motorcycle moves with shaking, then check its clutch pad for wearing. Replace it if necessary.

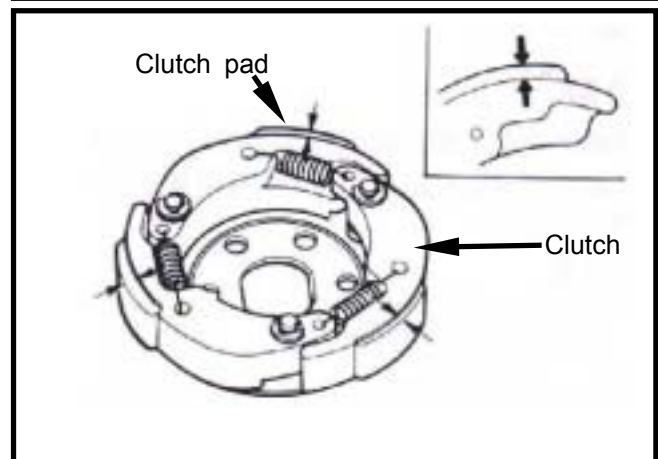

### STEERING SYSTEM

#### Caution

Check all wires and cables if they are interfered with the rotation of steering handle bar.

Lift the front wheel out of ground.  
Turn handle from right to left and check if turning is smoothly.  
If handle turning is uneven and bending, or the handle can be operated in vertical direction, then adjust the handle top bearing.



### SUSPENSION SYSTEM

#### Warning

- Do not ride the motorcycle with poor shock absorber.
- Looseness, wear or damage shock absorber will make poor stability and driveability.

#### Front shock absorber

Hold front brake lever and press down the front shock absorber for several times to check its operation.  
Hold front brake lever and push forward the front shock absorber for several times to check its locking status.  
Check if it is scratched or leaking.  
Replace damaged and non-repairable components.  
Tighten all nuts and bolts.

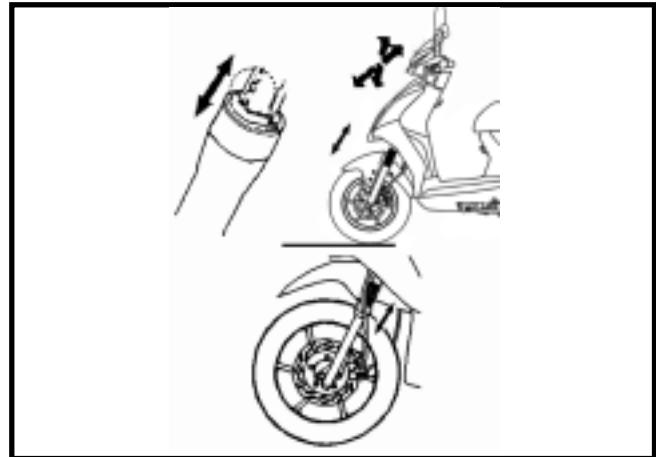

#### Rear Shock absorber

Press down the rear shock absorber for several times to check its operation.  
Check if it is scratched or leaking.  
Replace damaged and non-repairable components.  
Park the motorcycle with main standard.  
Start engine and let the rear wheel rotate after increased engine rpm. Check engine for any parts loose or shaking. Also check the engine suspension bushing for wear out.  
Replace the bushing if worn out.  
Tighten all nuts and bolts.



**FRONT DISC BRAKE SYSTEM**

**BRAKE SYSTEM HOSE**

Make sure the brake hoses for corrosion or leaking oil, and also check brake system for leaking.

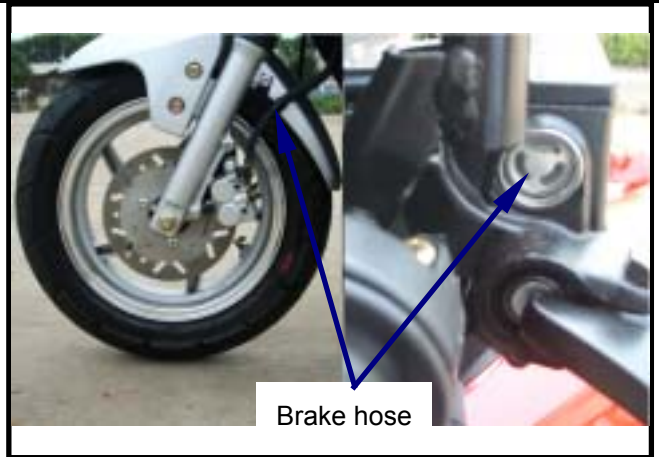

**BRAKE FLUID**

Check brake fluid level in the brake fluid reservoir. If the level is lower than the LOWER limit, add brake fluid to UPPER limit. Also check brake system for leaking if low brake level found.

**⚠ Caution**

- In order to maintain brake fluid in the reservoir in horizontal position, do not remove the cap until handle bar stop.
- Do not operate the brake lever after the cap had been removed. Otherwise, the brake fluid will spread out if operated the lever.
- Do not mix non-compatible brake fluid together.

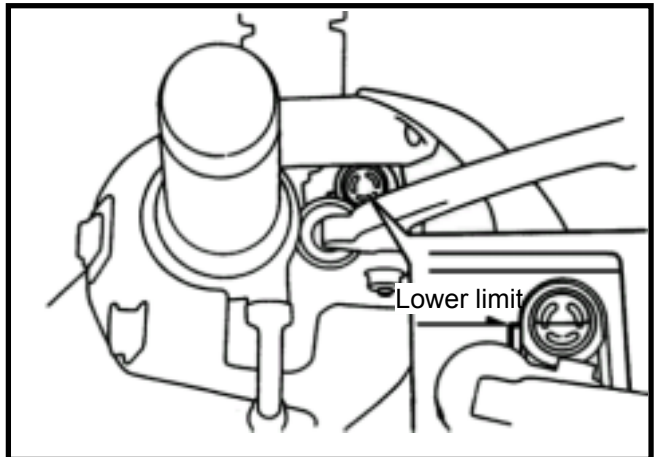

**FILLING OUT BRAKE FLUID**

Tighten the drain valve, and add brake fluid. Place the diaphragm in. Operate the brake lever so that brake fluid contents inside the brake system hoses.

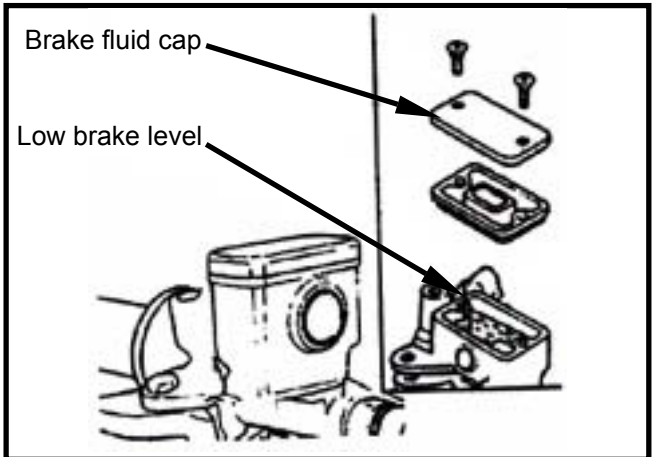

**AIR BLEED OPERATION**

Connect a transparent hose to draining valve. Hold the brake lever and open air bleeding valve. Perform this operation alternative until there is no air inside the brake system hoses.

**⚠ Caution**

Before closing the air bleed valve, do not release the brake lever.

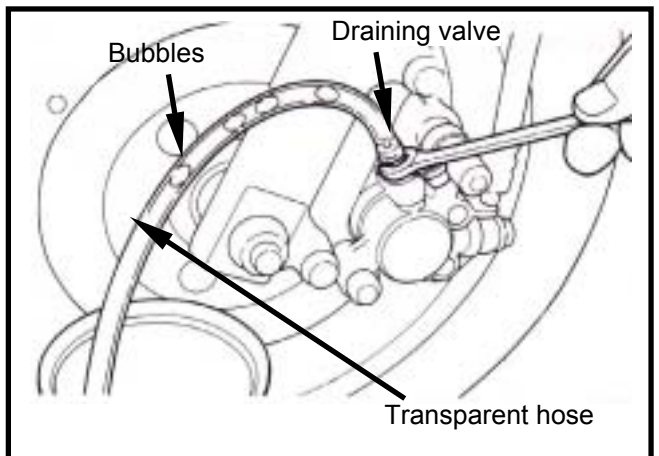



### ADDED BRAKE FLUID

Add brake fluid to UPPER limit lever.  
Recommended brake fluid: DOT3 or DOT4  
WELL RUN brake fluid.

**⚠ Caution**

Never mix or use dirty brake fluid to prevent from damage brake system or reducing brake performance.

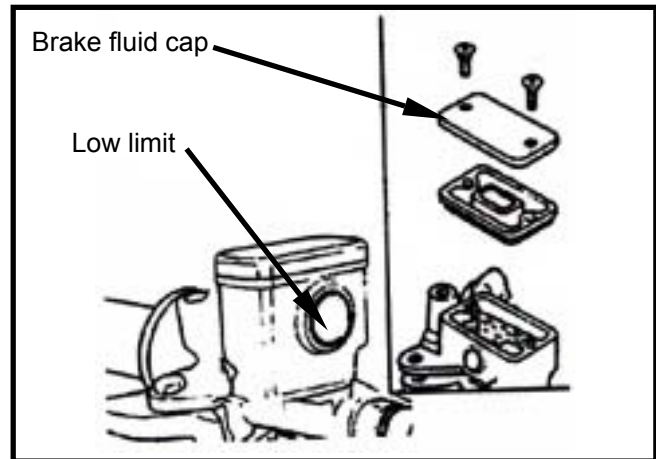

### BRAKE LINING WEAR

The indent mark on brake lining is the wear limitation.

Replace the brake lining if the wear limit mark closed to the edge of brake disc.

**⚠ Caution**

It is not necessary to remove brake hose when replacing the brake lining.

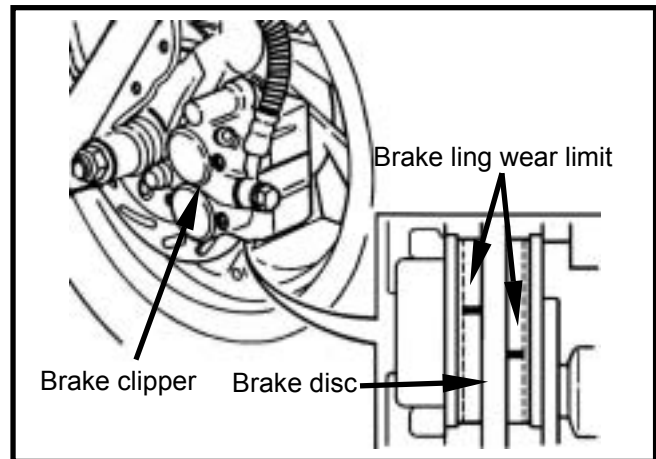

Remove the brake clipper bolt, and take out the clipper.

**⚠ Caution**

Do not operate the brake lever after the clipper removed to avoid clipping the brake lining.

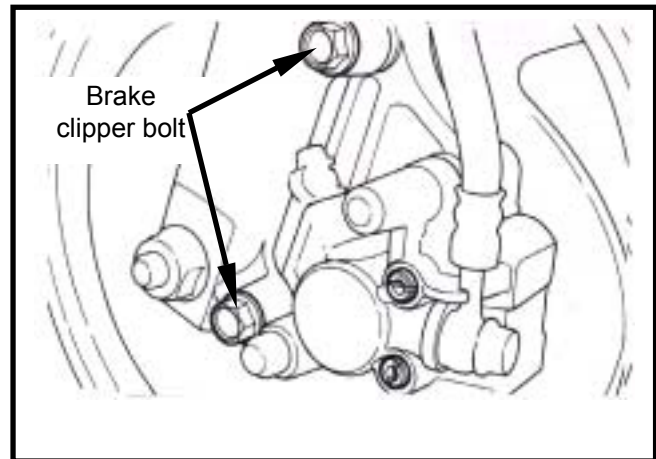

Pry out the brake lining with a flat driver if lining be clipped.

Remove brake lining bolt.  
Take out the lining.

**⚠ Caution**

In order to maintain brake power balance, the brake lining must be replaced with one set.

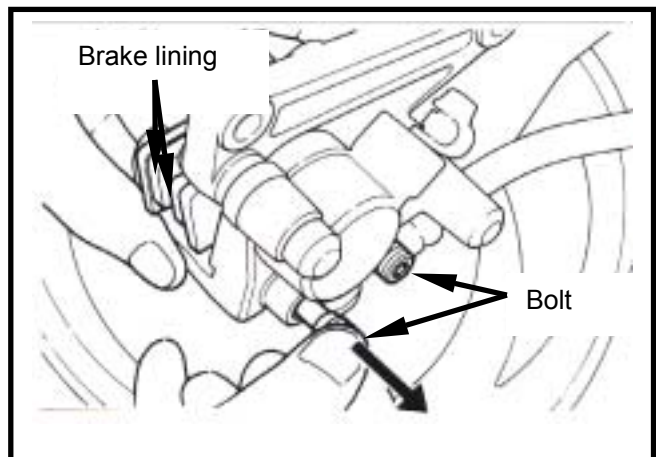

**DRUM BRAKE SYSTEM**

**Front Brake Free Play: (Drum brake)**

Measure free play of rear brake level at the end of the lever.

**Free play: 10-20 mm**

Adjust the free play by turning the front brake adjustment nut if necessary.

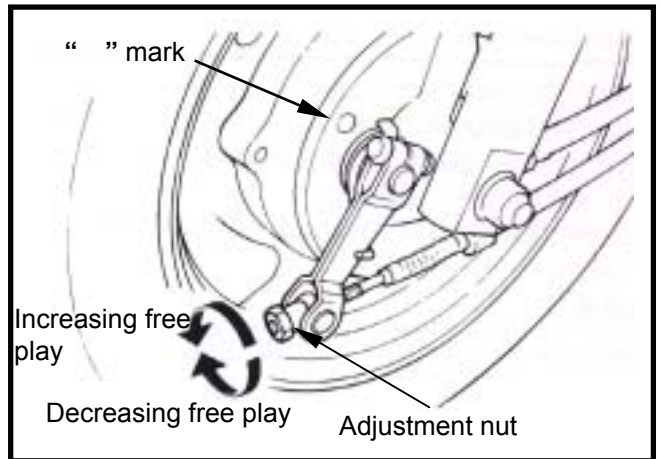
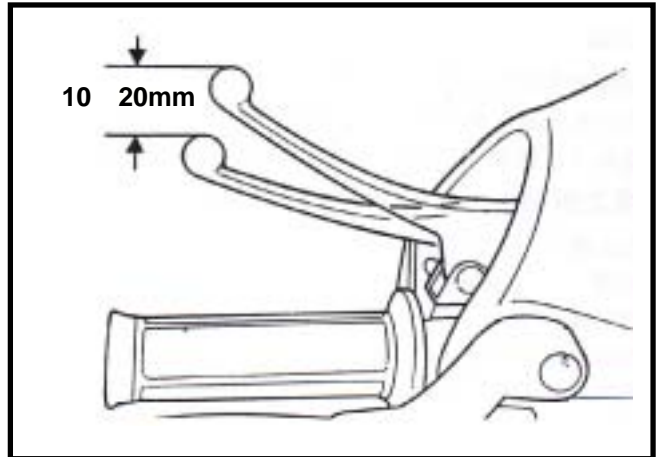

**REAR BRAKE FREE PLAY: (DRUM BRAKE TYPE)**

Measure the free play of the front brake lever at the end of the lever.

**Free play: 10-20 mm**

Adjust the free play by turning the front brake adjustment nut if necessary.



**BRAKE CONFIRMATION**

**⚠ Caution**

- After brake adjustment, it has to check the brake operation to make sure the front and rear wheel can be braked.
- Pull the brake lever, and make sure that the wear limit marks of brake lining on the both front & rear brake arm are closer and touch to the "' marks. If so, replace the brake lining with new one.



### BRAKE LIGHT SWITCH

The brake light switch is to lit up brake light as brake applied.

Make sure that electrical starter can be operated only under brake applying.

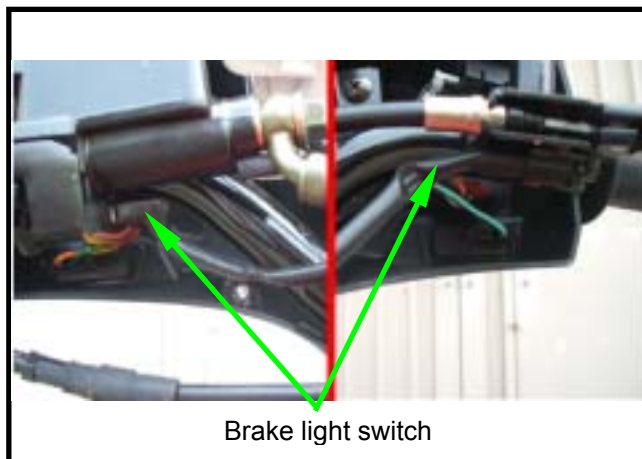

Brake light switch

### WHEEL/TIRE

Check if both front and rear tire pressure are within specification.

#### Caution

Tire pressure check should be done as cold tire.

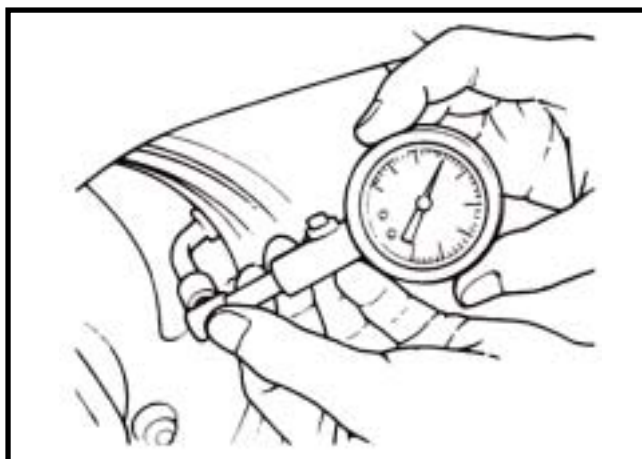

#### Appointed tire pressure

Tire size		Front tire	Rear tire
Tire pressure as cold tire (Kg/cm <sup>2</sup> )	Load for single	1.75	2.0
	Load for two persons	1.75	2.25

#### Appointed Tire

**Front/Rear wheel: 120/70-12 / 130/70-12**

Check if tire surface is ticked with nails, stones or other materials.

Check if tire surface or wall for crack or damaged, and replace it if necessary.

The tire tread depth can be checked by visual inspection or depth gauge.

- Replace the tire if tire tread dent or unusual wearing out.
- The tire should be replaced if the wear limit mark ( ) is in visible.

Measure tire thread depth from tire center surface.

Replace the tire if the depth is not come with following specification:

Front tire: 1.5 mm

Rear tire: 2.0 mm

#### Caution

The wear limit marks ( ) are located around the tire wall even for inspection.

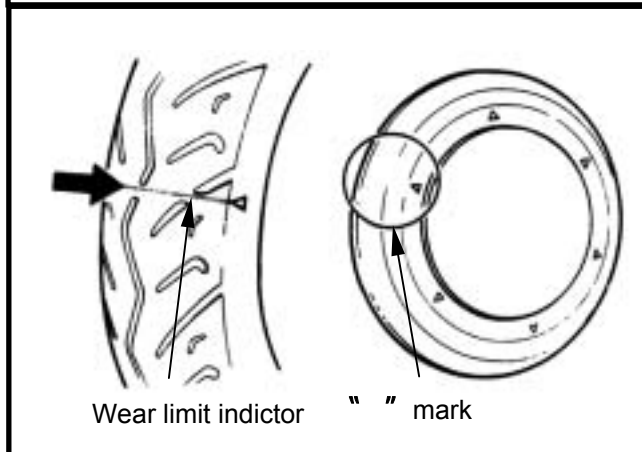
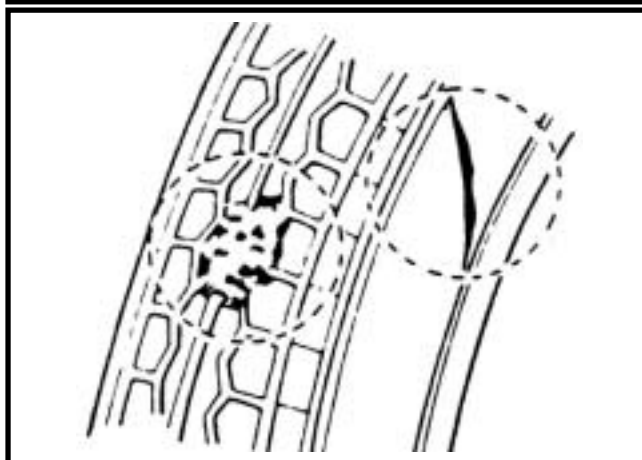

Wear limit indicator

" " mark

## BATTERY

### Battery Removal

Remove the 4 screws on the floor panel.  
Remove battery cap. (4 screws)

Battery cables removal:

1. At first, remove the negative “-” cable.
2. Then, remove the positive “+” cable.
3. Remove the battery.

If there is some rust on battery posts, clean it with steel brush.

Install the battery in the reverse procedures of removal.

### ⚠ Caution

- If there is rust on the posts very serious, spray some hot water on the posts. Then, clean it with steel brush so that can remove rust for more easily.
- Apply some grease on the posts after rust removed to prevent from rust again.

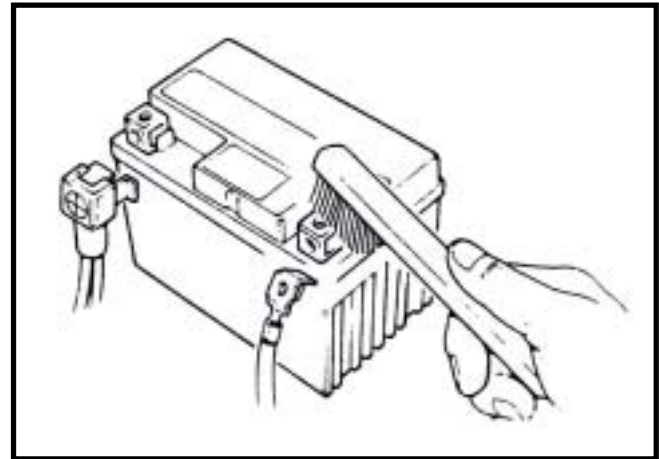
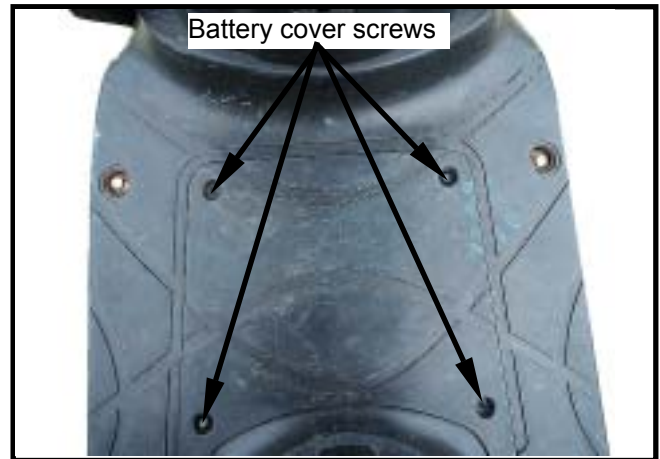

## HEADLIGHT ADJUSTMENT

Remove the front cover.

Turn on the main switch.

Turn the headlight adjustment screw. And adjust the headlight beam height.

Then, tighten the adjustment screw after the beam height in proper position.

### ⚠ Caution

- To adjust the headlight beam follows related regulations.
- Improper headlight beam adjustment will make in coming driver dazzled or insufficient lighting.

## NUTS, BOLTS TIGHTENESS

Perform periodical maintenance in accord with the Periodical Maintenance Schedule. Check if all bolts and nuts on the frame are tightened securely.

Check all fixing pins, snap rings, hose (pipe) clamps, and wire holders for security.



MECHANISM DIAGRAM .....3-1	CLEANING ENGINE OIL STRAINER...3-3
OPERATIONAL PRECAUTIONS .....3-2	OIL PUMP .....3-4
TROUBLE DIAGNOSIS.....3-2	GEAR OIL .....3-7
ENGINE OIL .....3-3	

**MECHANISM DIAGRAM**

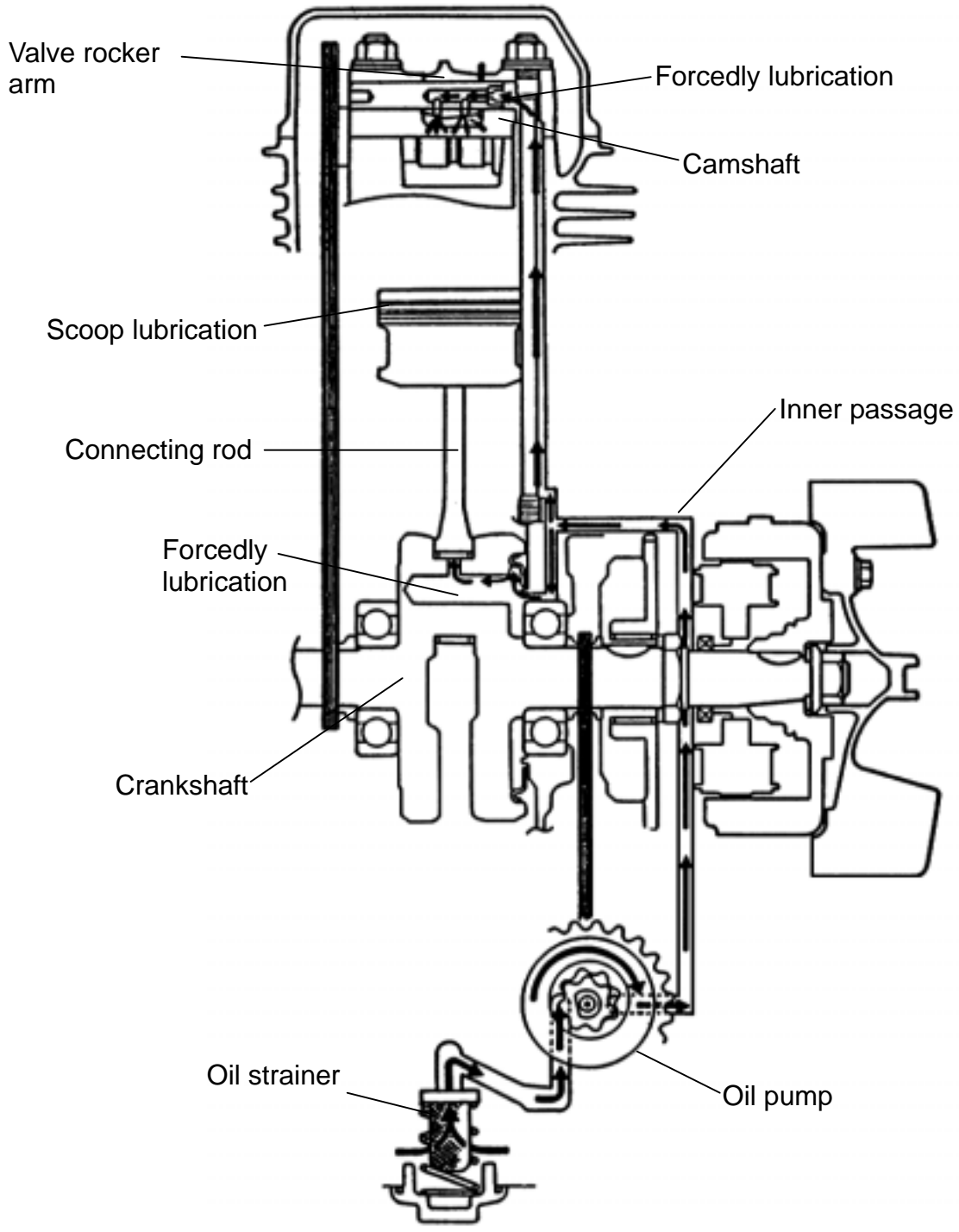

#### OPERATIONAL PRECAUTIONS

##### General Information

- This chapter contains maintenance operations for the engine oil pump, engine oil and gear oil.

##### Specifications

Engine oil quantity	Disassembly 850 c.c. Replacement 750 c.c.
Oil viscosity	SAE 10W-30 or equivalent (Recommended King-Mate serial oils)
Gear Oil	Disassembly 120 c.c. Replacement 110 c.c.
Oil viscosity of gear oil	SAE 85W-140 (Recommended King-Mate gear oil series SYM HYPOID GEAR OIL)

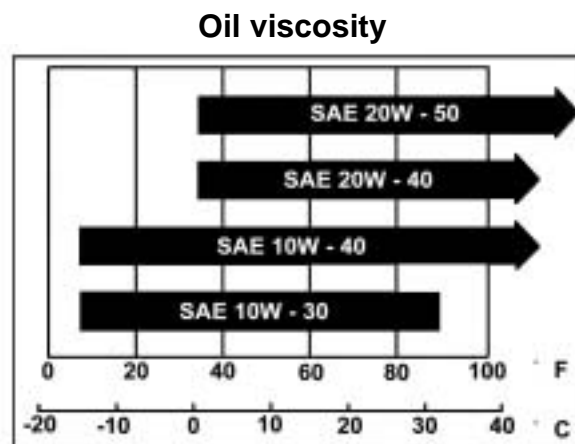

unit : mm

Items		Standard	Limit
Oil pump	Inner rotor clearance	-	0.12
	Clearance between outer rotor and body	-	0.12
	Clearance between rotor side and body	0.05~0.10	0.20

##### Torque value

Engine oil drain plug	3.5~4.5kgf-m
Engine oil screen cover	1.3~1.7kgf-m
Gear oil drain bolt	0.8~1.2kgf-m
Gear oil filling bolt	1.0~1.4kgf-m
Oil pump connection screw	0.1~0.3kgf-m

#### TROUBLE DIAGNOSIS

##### Low engine oil level

- Oil leaking
- Valve guide or seat worn out
- Piston ring worn out

##### Dirty oil

- No oil change in periodical
- Cylinder head gasket damage
- Piston ring worn out

##### Low Oil Pressure

- Low engine oil level
- Clogged in oil strainer, circuits or pipes
- Oil pump damage

**ENGINE OIL**

Turn off engine, and park the motorcycle in flat ground with main stand.  
 Check oil level with oil dipstick after 3-5 minutes.  
 Do not rotate the dipstick into engine as checking.  
 If oil level is nearly low level, fill out recommended oil to upper level.

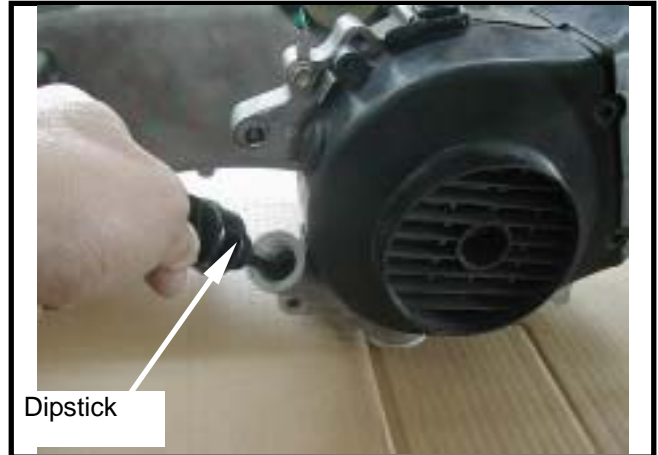

**Oil Replacement**

**⚠ Caution**

Drain oil as engine warmed up so that make sure oil can be drained smoothly and completely.

Place an oil pan under the motorcycle, and remove oil strainer cap.  
 Make sure if the aluminum washer of the draining bolt is damaged. If so, replace it with new one.  
 Install the drain bolt and tighten it.

**Torque value: 3.5~4.5 kgf-m**

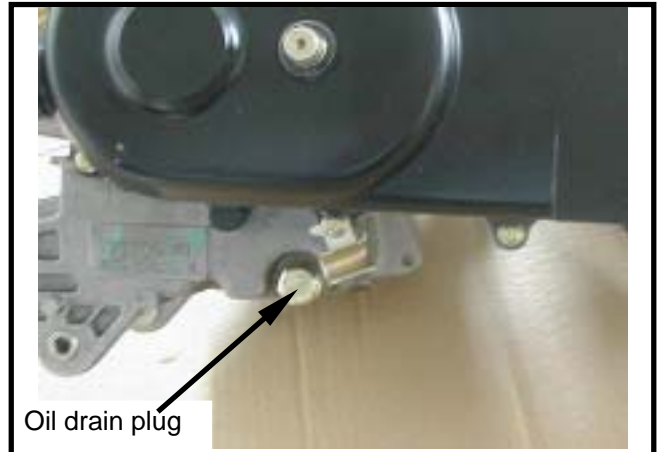

**CLEANING ENGINE OIL STRAINER**

Remove the oil strainer cap.  
 Remove oil strainer and spring.  
 Clean oil strainer (recommended using compressed air to clean dirty foreign).  
 Check if the strainer and O-ring of the oil strainer are broken. Replace with new one if found.  
 Install the oil strainer and spring.  
 Install the oil strainer cap and tighten it.

**Torque value: 1.3~1.7 kgf-m**

Fill out oil to the oil filler (Oil viscosity SAE 10W-30) (Recommended King-Mate serial oils).

**Engine oil quantity: Replacement 850 c.c.**

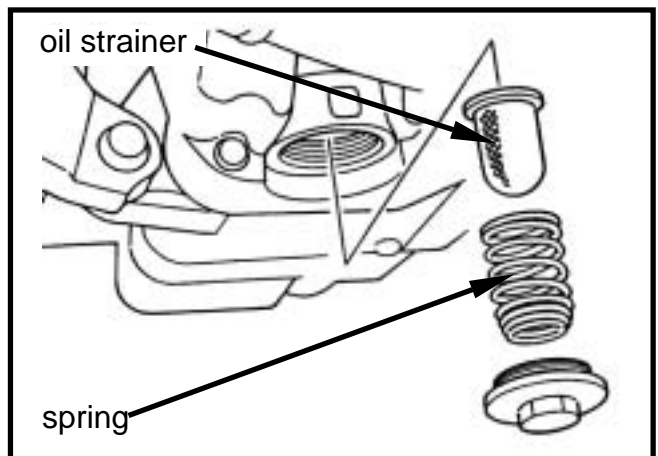
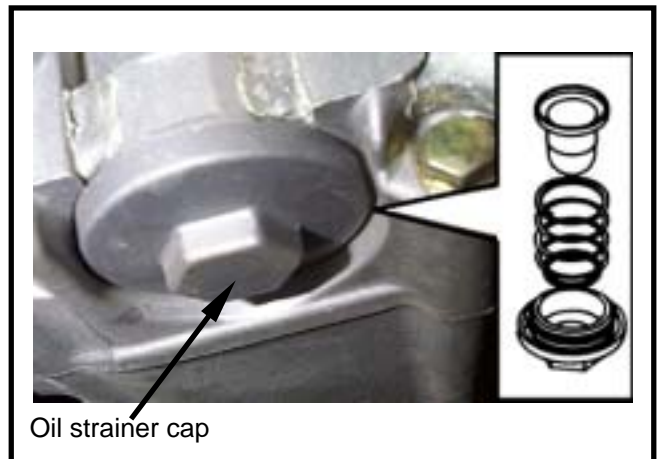

#### OIL PUMP

##### Oil Pump Removal

Remove the alternator (refer to chapter10).  
Remove the engine right crankcase cover.  
Make sure that the pump axle can be rotated freely.  
Remove the oil pump driving gear nut.



Remove oil pump body bolts (3 bolts).

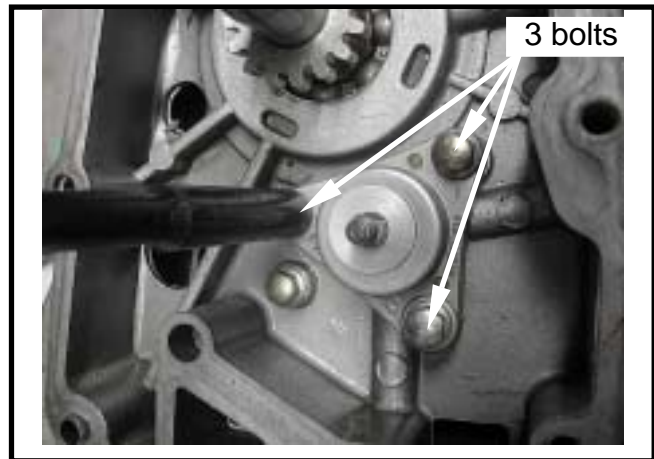

Remove the oil pump pin.  
Remove the oil pump.

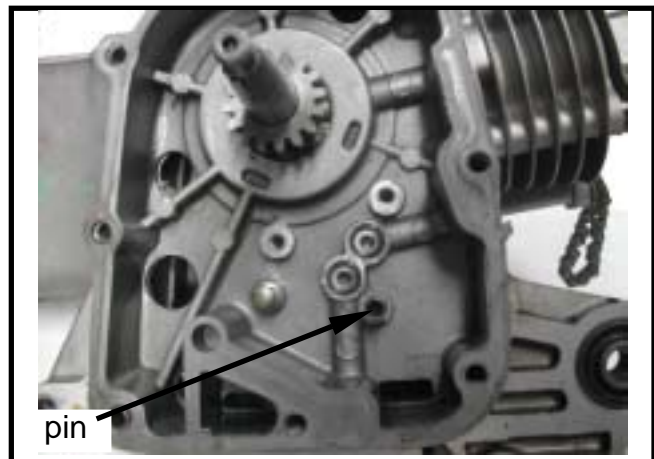

Remove the 2 O-rings.

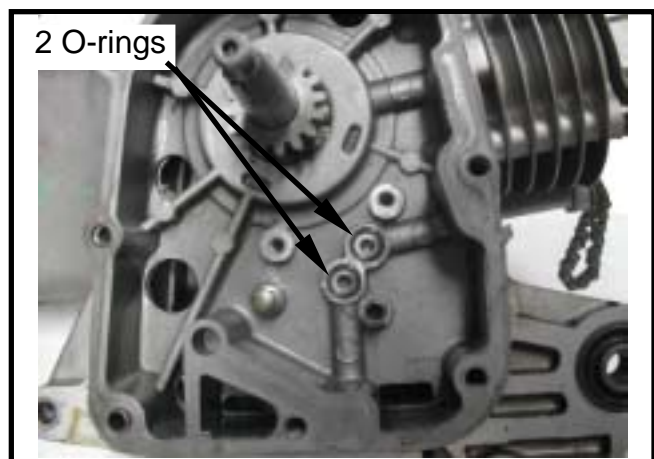



**Oil Pump Inspection**

Check the clearance between oil pump body and outer rotor.

**Limit: below 0.12 mm**



Check clearance between inner and outer rotors.

**Limit: below 0.12 mm**



Check clearance between rotor side face and pump body.

**Limit: below 2.0 mm**



**Oil Pump Re-assembly**

Install inner and outer rotors into the pump body.

Align the indent on driving shaft with that of inner rotor. Install the driving shaft.

Install the oil pump cover and fixing pin properly and then tighten screw. (1 screw)



#### Oil Pump Installation

Install the 2 O-rings.

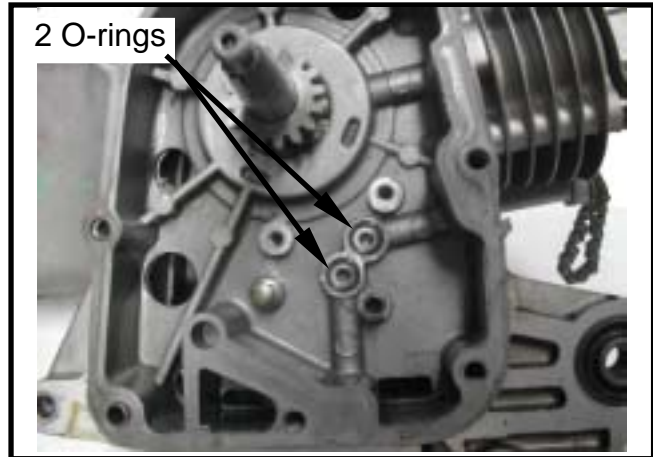

Install the oil pump pin.

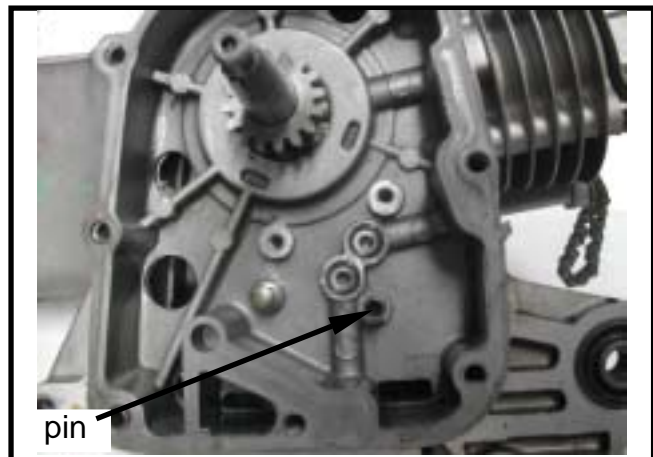

Install the oil pump.  
Install the oil pump body bolts (3 bolts).

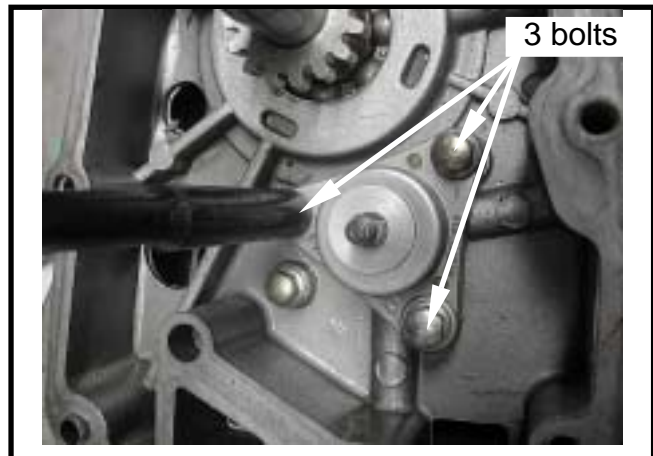

Install the oil pump driving gear nut.  
Install the alternator (refer to chapter10).  
Install the engine right crankcase cover.



## GEAR OIL

### Oil Level Inspection

Park the motorcycle on flat ground with main stand.

Turn off engine and remove both engine oil filling bolt and oil draining bolt.

Remove gear oil filling hole bolt and place a measurement cup under the draining plug. Remove the oil draining plug and the pour gear oil into the measurement cup. Measure the gear oil quantity if within standard value.

Add specified gear oil if the oil level too low.

Standard quantity: 100cc.

Replacement: 90 cc.

### Gear Oil Replacement

Remove the gear oil filling hole bolt and its draining plug and then drain oil completely. Install the draining plug and tighten it. (Make sure if the plug washer is damaged. If so, replace it with new one.)

### Torque Value : 0.8~1.2 kgf-m

Add new gear oil (100 c.c.) from the gear oil filling hole and then install the gear oil filling hole bolt after added oil. And then, tighten the bolt.

### Torque Value: 1.0~1.4 kgf-m

**Recommended to apply with SYM**

### HYPOLID GEAR OIL (SAE 85W-140)

Start engine and run it for 2~3 minutes.

Turn off engine and check if oil leaking.

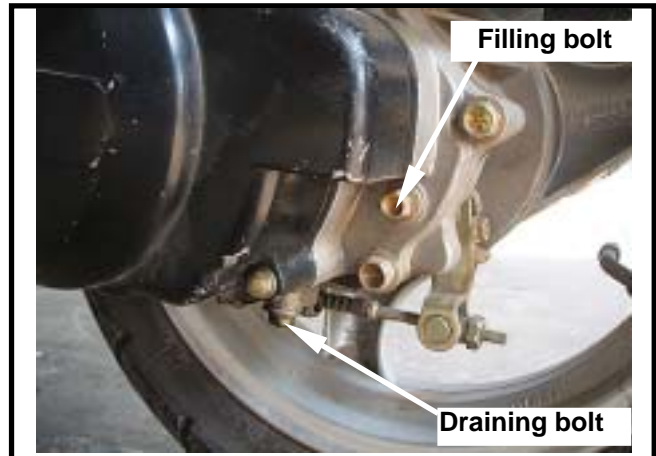

MECHANISM ILLUSTRATION .....	4-1	AUTO BY-STARTER .....	4-7
PRECAUTIONS IN OPERATION .....	4-2	FLOAT CHAMBER .....	4-8
TROUBLE DIAGNOSIS .....	4-3	INSTALLATION OF CARBURETOR ..	4-9
CARBURETOR REMOVAL .....	4-4	IDLE SPEED ADJUSTMENT.....	4-9
VACUUM CHAMBER .....	4-4	FUEL TANK.....	4-10
AIR CUT-OFF VALVE .....	4-6	AIR CLEANER.....	4-11

**MECHANISM ILLUSTRATION**

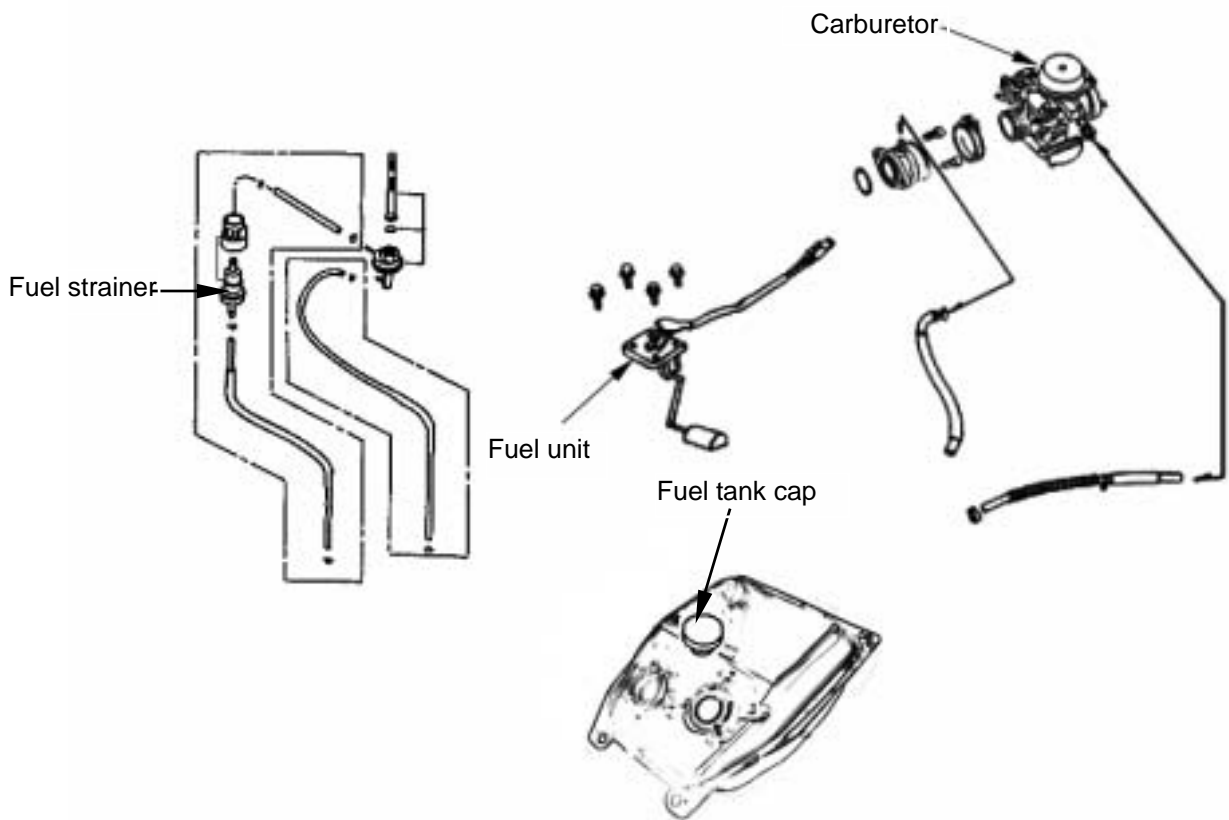

### PRECAUTIONS IN OPERATION

#### General Information

#### Warning

Gasoline is a low ignition point and explosive materials, so always work in a well-ventilated place and strictly prohibit flame when working with gasoline.

#### Cautions

- Do not bend or twist throttle valve cable. Damaged cable will make unstable driveability.
- When disassembling fuel system parts, pay attention to O-ring position, replace with new one as re-assembly
- There is a drain screw in the float chamber for draining residual gasoline.
- Do not disassemble automatic by-starter and air cut-off valve arbitrarily.

### Specification

Item	Specification
Venturi diameter	24 mm
I.D. number	063c
Level in float chamber	18.5±0.5 mm
Main injector	# 110
Idle(pilot) injector	# 35
Idle speed	1700±100 rpm
Throttle handle free play	2~6 mm
Fuel quantity adjustment screw	1 3/4±3/4 turns

### Torque value

Fuel valve tightening nut: 1.5~2.0 Kgf-m

### Tool

#### Special service tools

Vacuum/air pressure pump

#### General service tools

Fuel level gauge

**TROUBLE DIAGNOSIS****Poor engine start**

- No fuel in fuel tank
- Clogged fuel tube
- Too much fuel in cylinder
- No spark from spark plug (malfunction of ignition system)
- Clogged air cleaner
- Malfunction of automatic by-starter
- Malfunction of throttle valve operation

**Stall after started**

- Malfunction of automatic by-starter
- Incorrect ignition timing
- Malfunction of carburetor
- Dirty engine oil
- Air existing in intake system
- Incorrect idle speed

**Rough idle**

- Malfunction of ignition system
- Incorrect idle speed
- Malfunction of carburetor
- Dirty fuel

**Intermittently misfire as acceleration**

- Malfunction of ignition system

**Late ignition timing**

- Malfunction of ignition system
- Malfunction of carburetor

**Power insufficiency and fuel consuming**

- Fuel system clogged
- Malfunction of ignition system

**Mixture too lean**

- Clogged fuel injector
- Vacuum piston stick and closed
- Malfunction of float valve
- Fuel level too low in float chamber
- Clogged fuel tank cap vent
- Clogged fuel filter
- Obstructed fuel pipe
- Clogged air vent hose
- Air existing in intake system

**Mixture too rich**

- Clogged air injector
- Malfunction of float valve
- Fuel level too high in float chamber
- Malfunction of automatic by-starter
- Dirty air cleaner

### Carburetor Removal

Remove the luggage box.  
 Loosen the adjustment nut and fixing nut of throttle valve cable, and release the cable from carburetor.  
 Remove fuel pipe, vacuum hose.  
 Disconnect auto by-starter connectors.  
 Release the clamp strip of air cleaner.  
 Release the clamp strip of carburetor isolator.  
 Take the carburetor out.

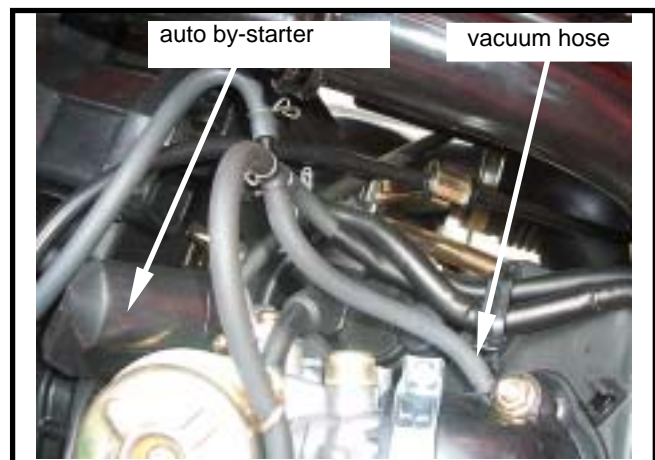
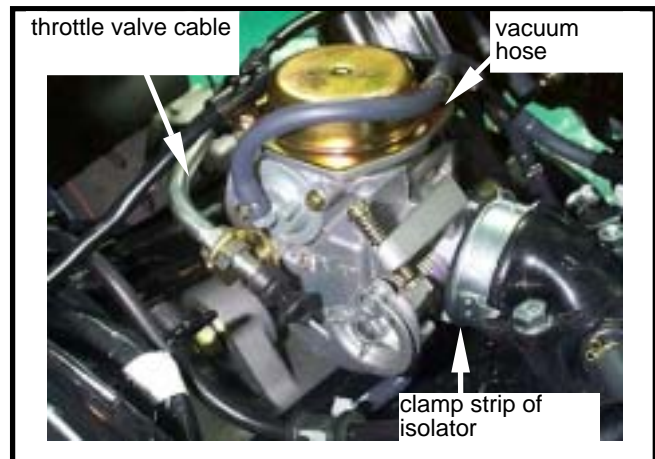

### VACUUM CHAMBER Removal

Loosen drain screw, and drain out residual fuel in float chamber.  
 Remove screws (2 screws) of vacuum chamber cover and the cover.

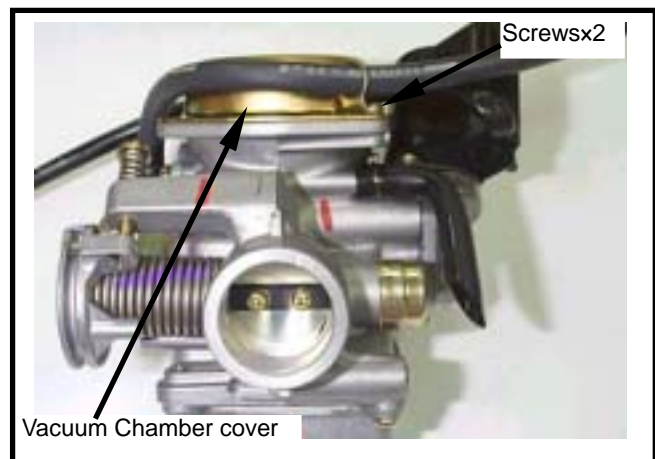

Remove compress spring and vacuum piston.

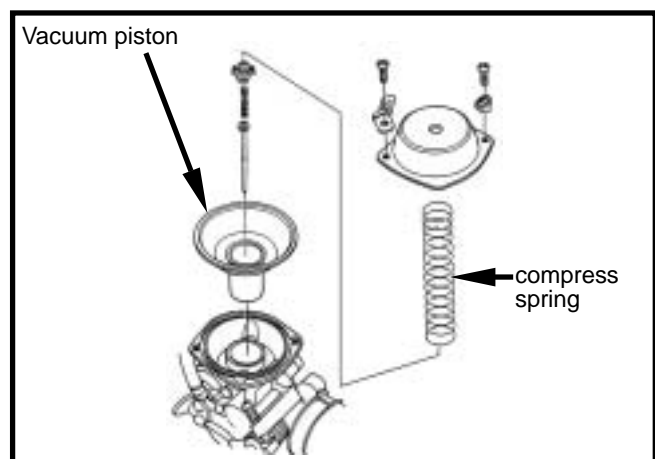

Remove fuel needle seat, spring, and injector needle.  
 Check if the vacuum piston for wear out, crack or other damage.  
 Check if the diaphragm for damage or crack.

**⚠ Cautions**

Do not damage vacuum diaphragm.

**Installation**

Install injector needle, spring and fuel needle seat to vacuum piston.

**⚠ Cautions**

- Note direction as installing the piston set because wrong direction of the piston can not be installed.
- Align the indent of vacuum diaphragm with the carburetor body.

Install vacuum piston to carburetor body.  
 Install compress spring.

Install vacuum chamber cover and tighten 2 screws.

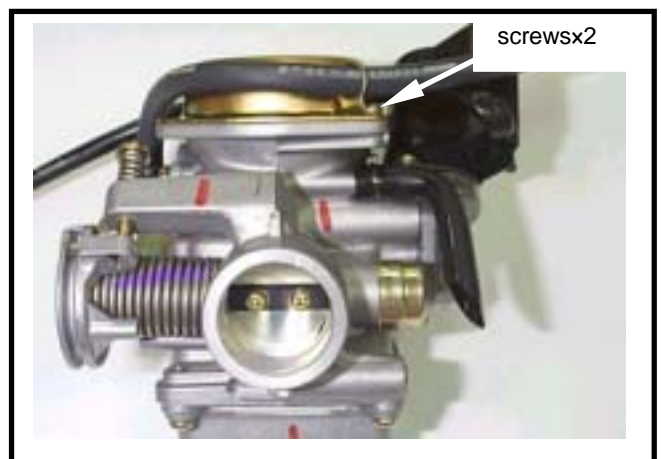
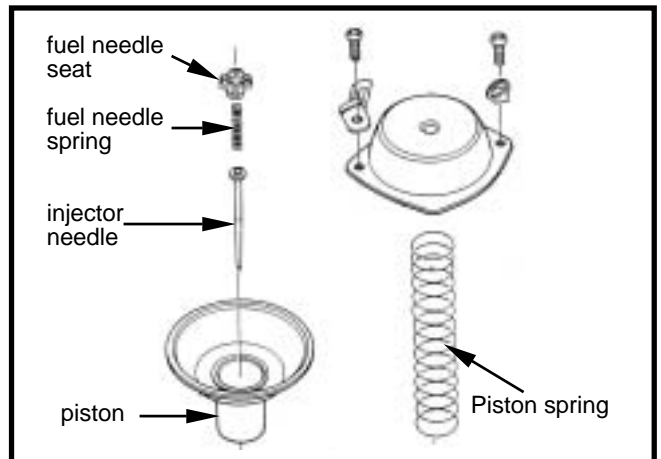



### AIR CUT-OFF VALVE

#### Removal

Remove the vacuum hose clamp and then the vacuum hose.

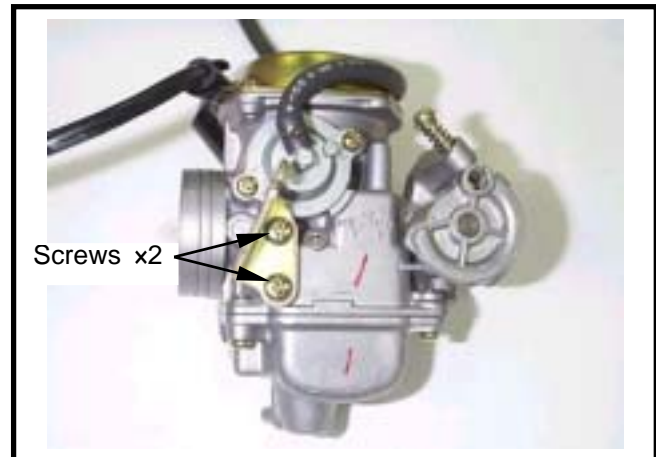

Remove the screws (screw x 2) of the air cut-off valve and its cover.

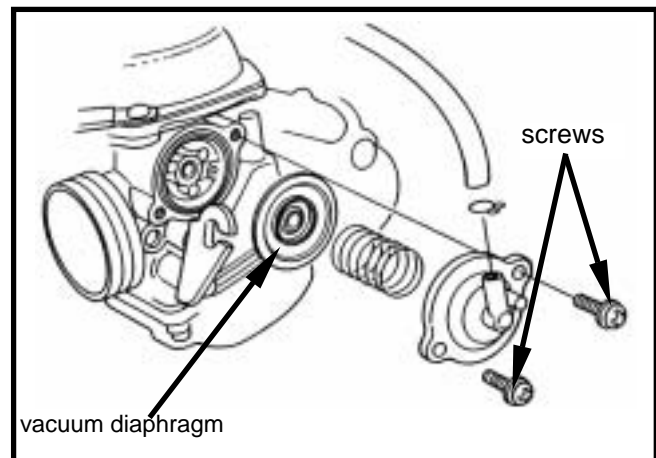

Remove the spring and vacuum diaphragm. Check if the vacuum diaphragm for deterioration or crack.

#### Installation

Install the valve as reverse order of removal.

#### Cautions

Do not damage the vacuum diaphragm or in opposite installation direction.



**AUTO BY-STARTER**

**Inspection**

Turn off engine and waiting for over 10 minutes for cooling.  
Check resistance across the two terminals of the auto by-starter

**Resistance value: Max. 10 (Measured after engine stopped for more than 10 minutes)**

Replace the auto by-starter with a new one if resistance value exceeds standard.

Remove the carburetor, allow it to cool off for 30 minutes.

Connect a hose to fuel richment circuit.

Pump compressed air to the circuit.

Replace the auto by-starter if the circuit clogged.

Connect battery posts (12V) to starter's connectors. After 5 minutes, test the rich circuit with compressed air. If air flow through the circuit, then replace the starter.

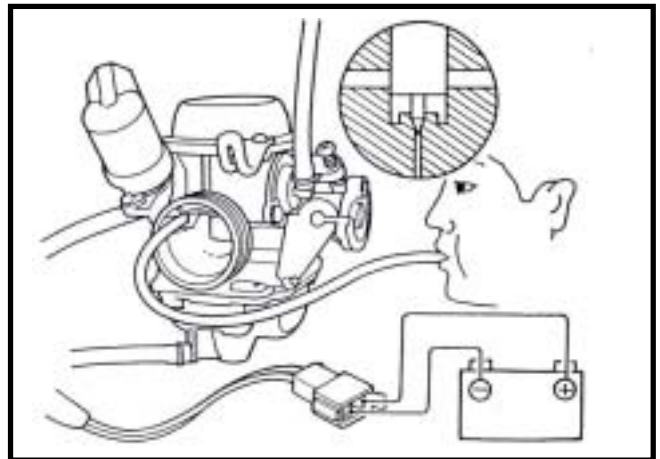
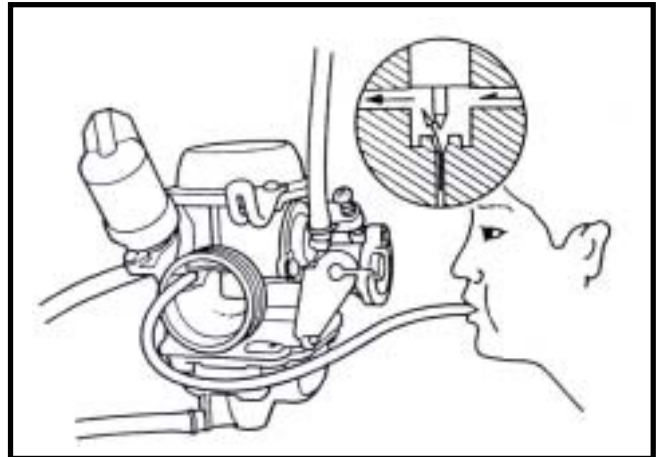

**Removal**

Remove fixing plate screw, and then remove the plate and auto by-starter from carburetor.

**Valve inspection**

Check if auto by-starter and valve needle for damage or wear out.

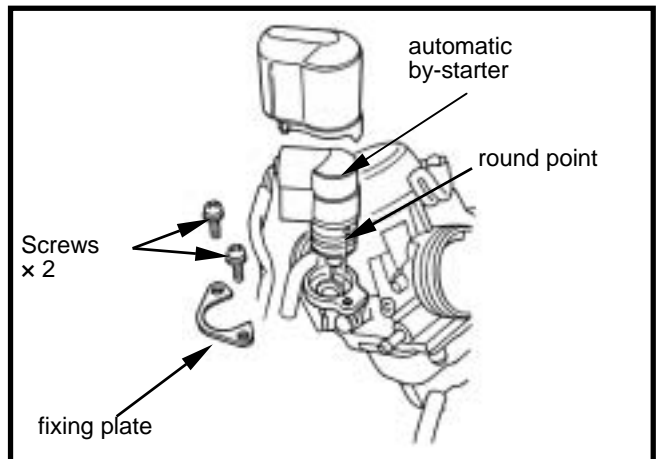

**Installation**

Install auto by-starter to the carburetor body. Install fixing plate to the upper groove of auto by-starter, and install its flat surface to carburetor. Install screw and tighten it.

**⚠ Cautions**

Align the round point of the starter with the screw hole of air intake side.

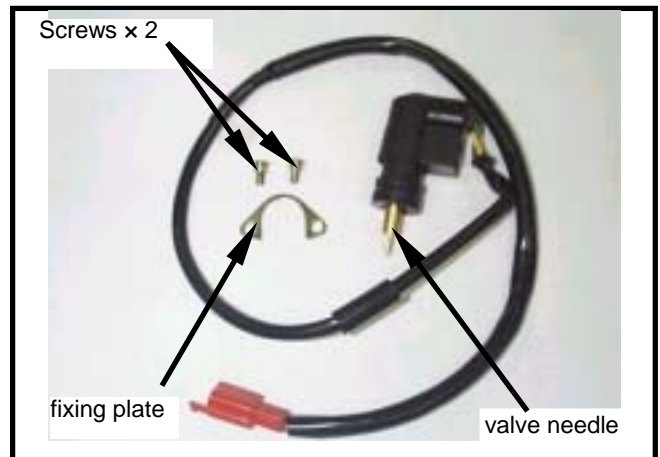

## FLOAT CHAMBER

### Disassembly

Remove 4 mounting screws and then the float chamber cover.

Remove the float pin and float valve.

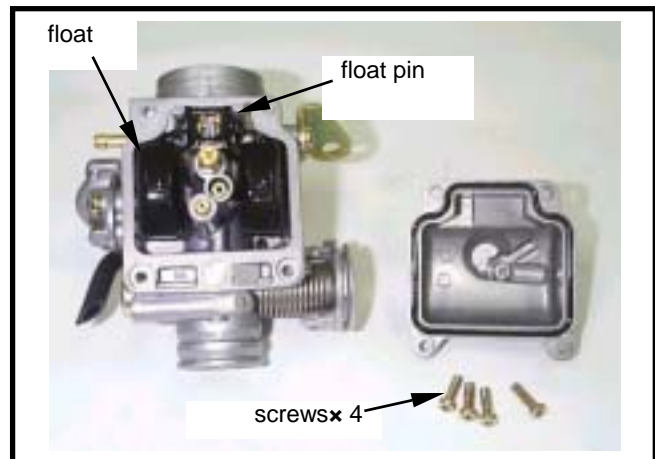

### Checking

Check float needle valve and valve seat for drop difference damage, wear out, dirty or clogged.

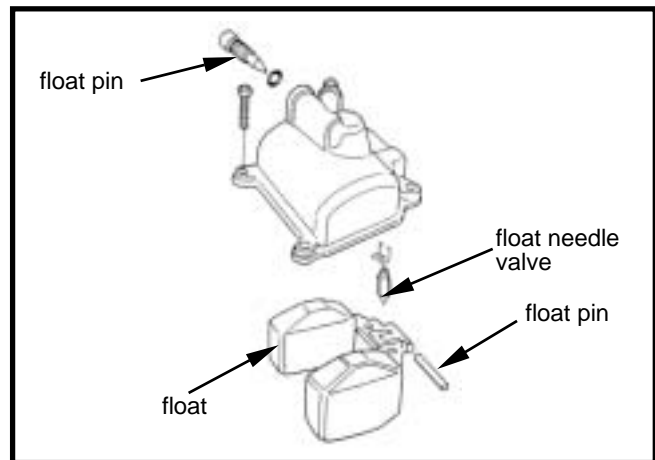

### Cautions

In case of worn out or dirt, the float valve and valve seat will not tightly close causing fuel level to increase and as a result, fuel flooding. A worn out or dirty float valve must be replaced with a new one.

Remove main jet, fuel needle jet holder, fuel needle jet, slow jet, fuel amount adjustment screw.

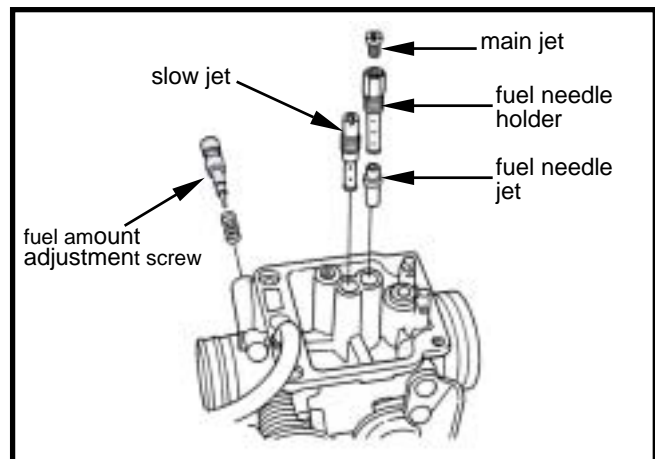

### Cautions

- Take care not to damage jets and adjust screw.
- Before removing adjustment screw, turn it all the way down and note the number of turns.
- Do not turn adjustment screw forcefully to avoid damaging valve seat face.

Clean jets with cleaning fluid. Then use compressed air to blow dirt off. Blow carburetor body passages with compressed air.

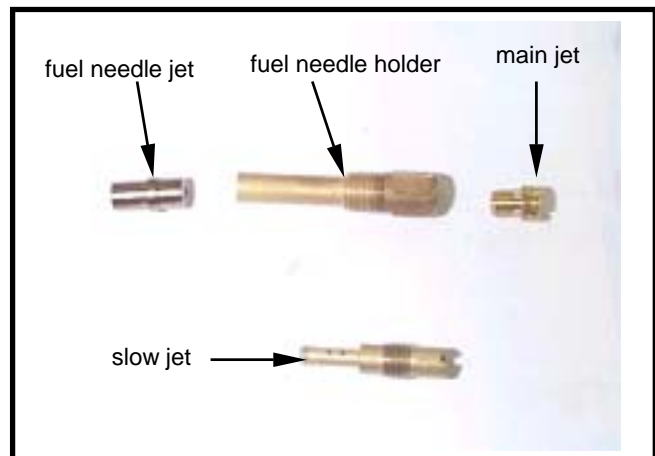

**Installation**

Install main jet, fuel needle jet seat, fuel needle jet, slow speed jet and fuel amount adjustment screw.

**⚠ Cautions**

Set the adjustment screw in according to number of turns noted before it was removed.

Install the float valve, float, and float pin.

**Checking Fuel Level**

**⚠ Cautions**

- Check again to ensure float valve, float for proper installation.
- To ensure correct measurement, position the float meter in such a way so that float chamber face is vertical to the main jet.

**Fuel level: 17.5 mm**

**INSTALLATION OF CARBURETOR**

Install carburetor in the reverse order of removal. Following adjustments must be made after installation.

- Throttle valve cable clearance adjustment
- Idle speed adjustment

**IDLE SPEED ADJUSTMENT**

**⚠ Caution**

- Fuel amount adjust screw was set at factory, so no adjustment is needed. Note the number of turns it takes to screw it all the way in for ease of installation.
- Never screw in forcedly to avoid damaging the screw seat.
- The main stand must be used to support the motorcycle to perform the adjustments.

Use a tachometer when adjusting engine RPM. Screw in adjustment screw gently, then back up to standard turns.

**Standard turns: 1 3/4±3/4 turns**

Warm up engine, adjust throttle valve stopper screw to standard RPM.

**Idle speed rpm: 1700±100 rpm**

Connect the sampling hose of exhaust analyzer to exhaust front end. Press test key on the analyzer. Adjust the air volume adjustment screw and read CO reading on the analyzer.

**CO standard value: 1.0~1.5 %**

Accelerate in gradual increments, make sure both rpm and CO value are in standard values after engine running in stable. If rpm and CO value fluctuated, repeat the procedures described above for adjusting to standard value.

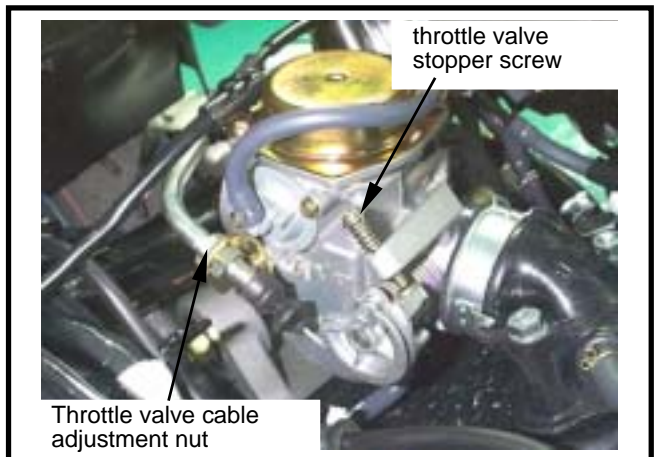
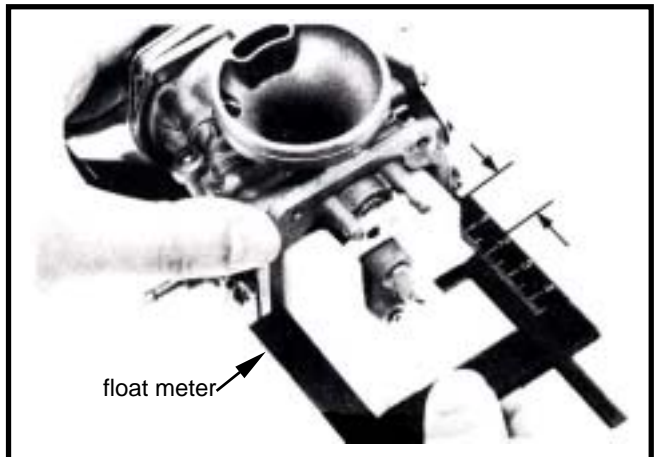
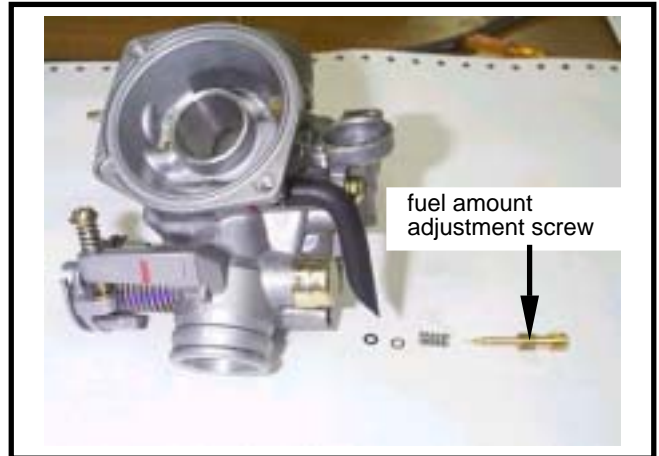

### FUEL TANK

#### Fuel unit removal

Remove the seat.  
Remove the rear carrier. (3 bolts)  
Remove the luggage box assembly (4 bolts).  
Disconnect fuel unit connector.  
Remove fuel unit.

#### Cautions

- Do not bend the float arm of fuel unit.
- Do not fill out too much gasoline to fuel tank.



Fuel unit inspection. (Refer to chapter 16 - electrical equipment).

#### Fuel unit installation

Install the gauge in the reverse order of removal.

#### Cautions

Do not forget to install the gasket of fuel unit or damage it.

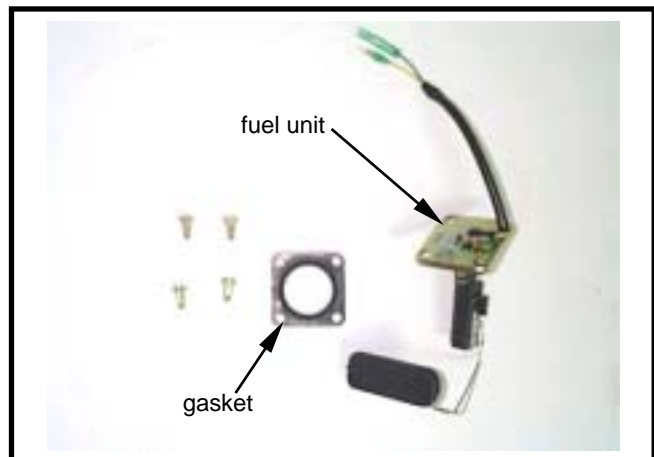

### FUEL TANK REMOVAL

Open the seat.  
Remove the rear carrier. (3 bolts)  
Remove the rear center cover.  
Remove the luggage box and the double seat (4 bolts).  
Remove the left & right body cover.  
Disconnect the fuel unit connector.  
Remove the fuel pipe, fuel filter.  
Remove the fuel tank (2 bolts).



#### Fuel Tank Installation

Install the tank in the reverse order of removal.

**AIR CLEANER**

**Removal**

- Remove the seat .
- Remove the luggage box assembly (4 bolts).
- Loosen the clamp strip of air cleaner.
- Remove evaporative return hose.
- Remove the air cleaner body bolts (2 bolts).
- Remove the air cleaner.



**Installation**

Install the air cleaner in the reverse order of removal.



**Air Cleaner Element Cleaning**

Remove the air cleaner cover (6 screws).

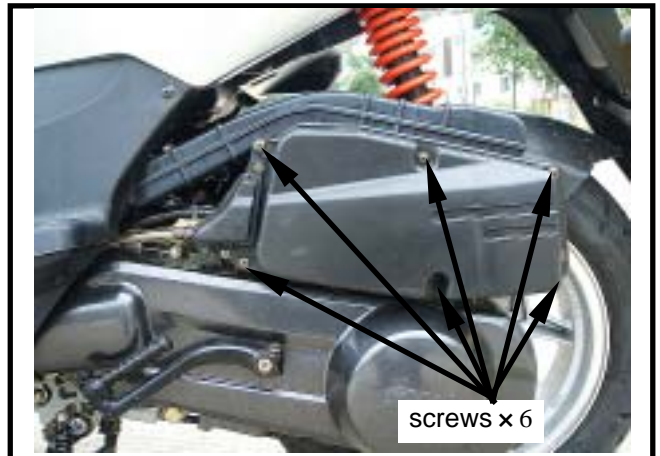

Remove the air cleaner element (2 screws).  
 With compressed air to clean dirty around the element. Replace it if it is too dirty to clean.

**⚠ Cautions**

The air cleaner element is made of paper so do not soap it into water or wash it with water.

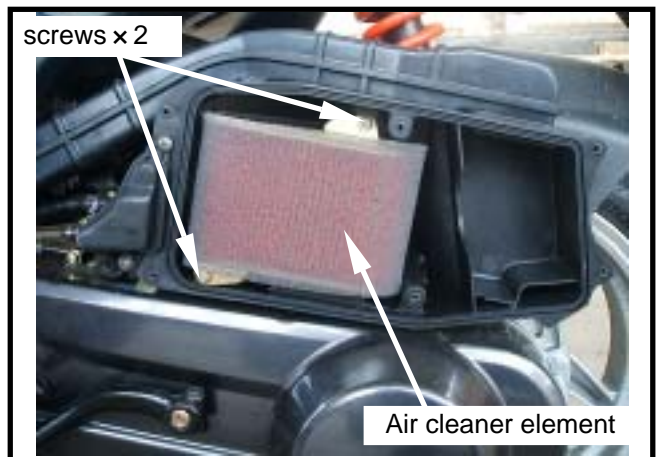

MECHANISM DIAGRAM ..... 5-1	REMOVAL OF ENGINE SUSPENSION BUSHING . 5-6
OPERATIONAL PRECAUTIONS ..... 5-2	ENGINE SUSPENSION FRAME ..... 5-7
ENGINE REMOVAL ..... 5-3	INSTALLATION OF ENGINE ..... 5-8

**MECHANISM DIAGRAM**

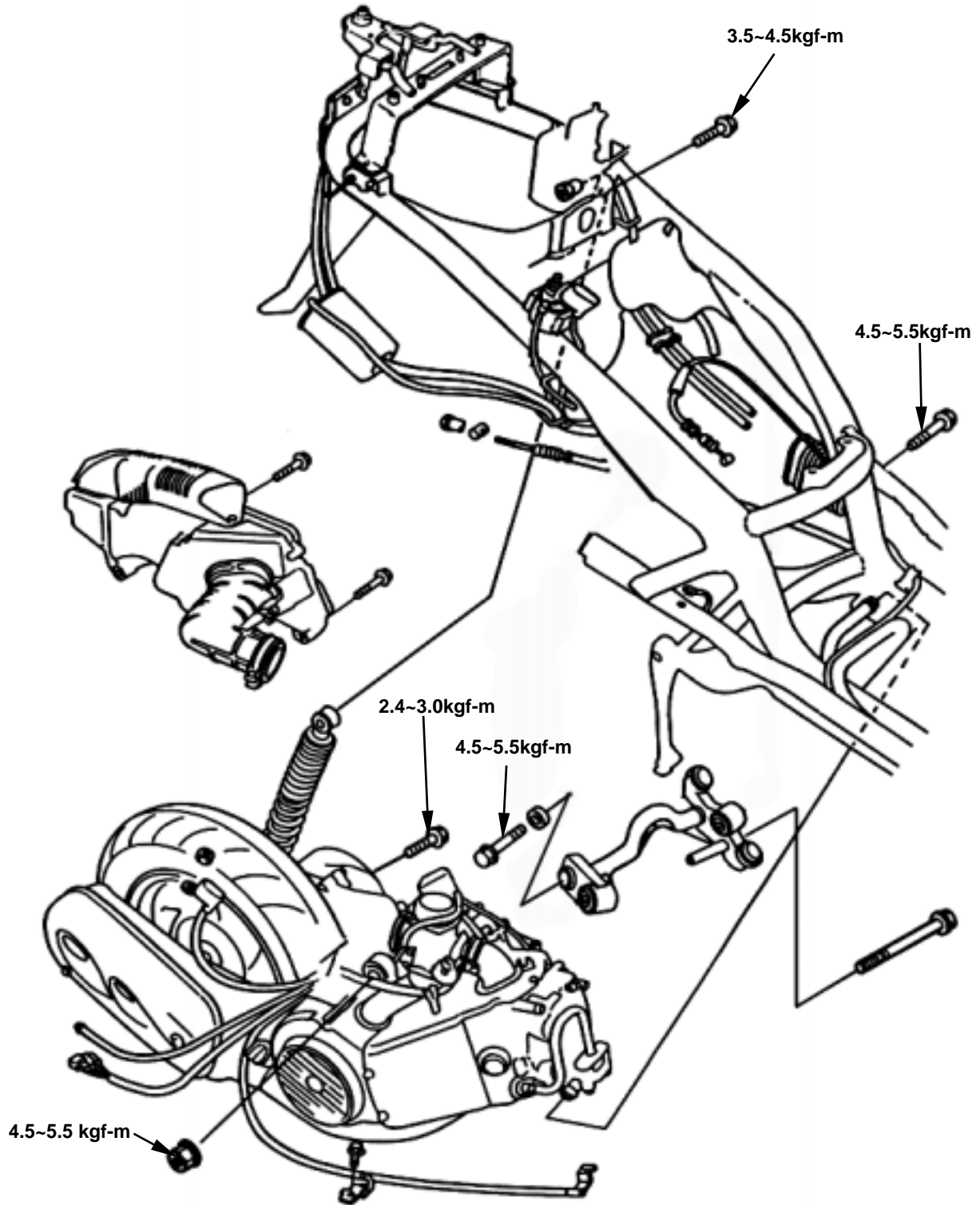

**OPERATIONAL PRECAUTIONS****General Information**

- Engine must be supported by a bracket or adjustable tool in height.
- The following parts can be serviced with the engine installed on the frame.
  1. Carburetor
  2. Driving disk, driving belt, clutch, and transporting disk
  3. Final reduction gear mechanism

**Specification**

		Specification
Engine Oil Capacity	Replacement	850 c.c.
	Disassemble	750 c.c.
Gear Oil Capacity	Replacement	100 c.c.
	Disassemble	110 c.c.

**Torque Values**

Engine suspension bolt (frame side)	4.5~5.5kgf-m
Engine suspension nut (engine side)	4.5~5.5kgf-m
Bolt of rear shock absorber upper connection	3.5~4.5kgf-m
Bolt of rear shock absorber lower connection	2.4~3.0kgf-m



**ENGINE REMOVAL**

Open the seat.  
Remove the luggage box assembly (4 bolts ).  
Remove the body cover .  
Remove the power connector of auto by-start.  
Remove the generator wire and pulse generator connector.

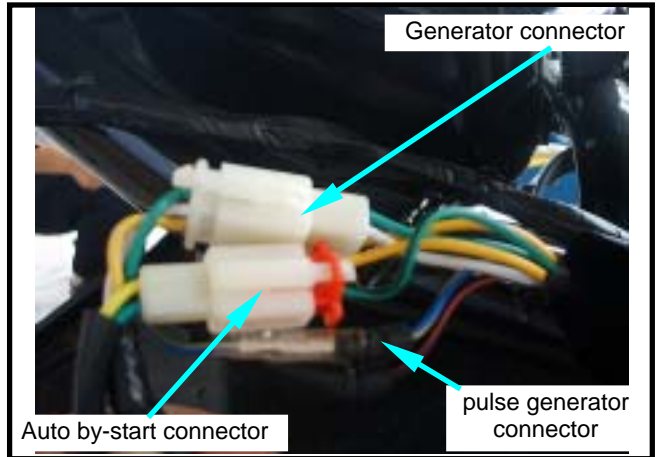

Remove the starter motor wire on the Starter magnetic switch.

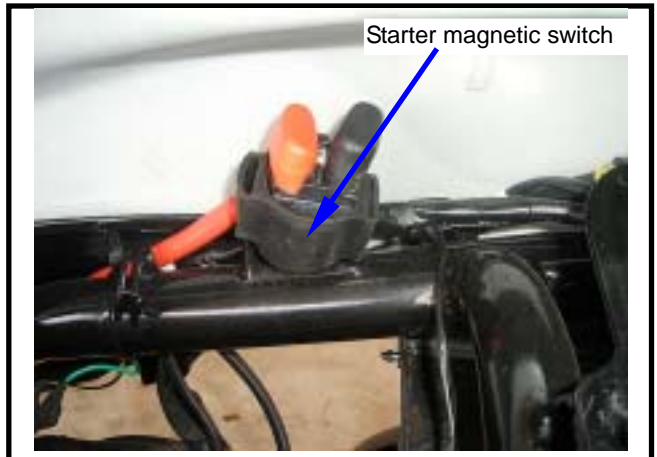

Remove the spark plug.

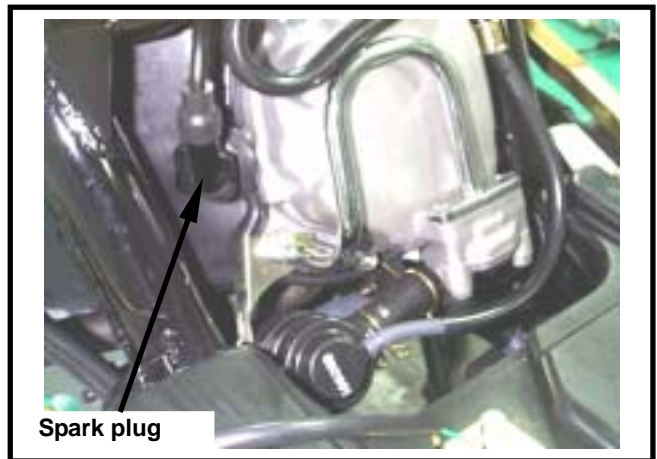

## 5. REMOVAL OF ENGINE

SYM

Remove the fuel pipe, vacuum hose, and throttle valve cable from the carburetor. Loosen the strap screw of the air cleaner guide, and then the air cleaner guide.



Remove the exhaust muffler (Bolts x 2, Nuts x 2).



Remove the rear wheel (Nut x 1).



Remove the air cleaner connection bolts (2 bolts).



Remove the rear brake cable nut.  
Remove the rear brake cable.  
Remove the rear shock absorber lower bolt.

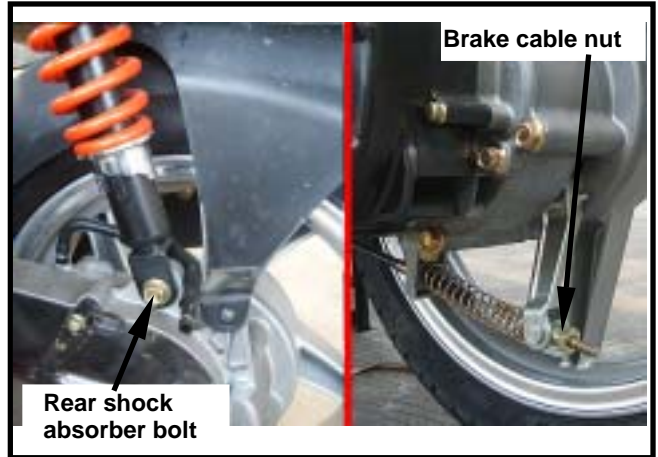

Loose the strap screw of engine left guide, and then remove the engine left guide.



Remove the engine suspension nut and bolt (engine side), and then remove the engine.

**⚠ Caution**

- With a bracket to support the engine to prevent from it damage by falling down as removing the engine.

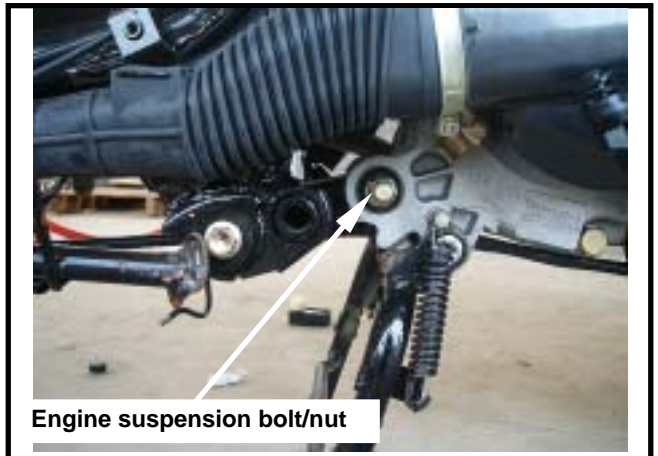

Check if the engine suspension, rear shock absorber bushing, and cushion rubber for damage. Replace them with new ones if so.

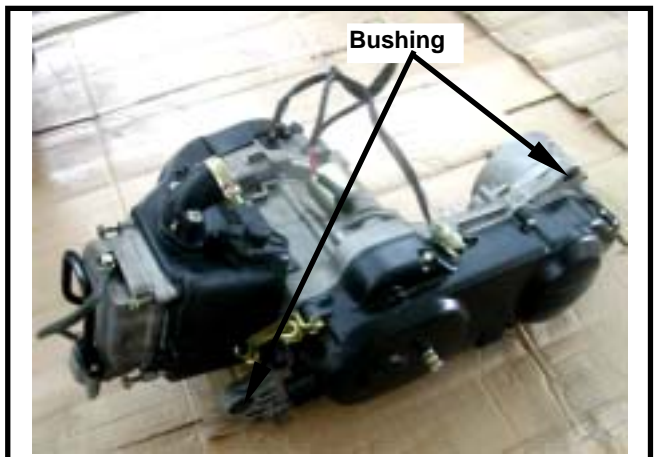

### REMOVAL OF ENGINE SUSPENSION BUSHING

If engine suspension frame and the cushion rubber of rear shock absorber bushing damaged. Then, with the bushing remover / presser, 28mm & 20mm, to press the bushing out, and replace it with new one.

Engine suspension bushing: **28mm**

Rear shock absorber bushing: **20mm**



#### Pressing out

Place the detent section of the bushing remover toward the bushing, and drive both the pressing ring and bolt in to press the bushing out.



#### Pressing In

Place the flat section of the remover toward the bushing, and then drive the bushing, pressing ring, and bolt in to install the bushing.



**ENGINE SUSPENSION FRAME****Removal**

Remove the right side bolt of engine suspension frame.



Remove the left side bolt of engine suspension frame.



Check if the engine suspension frame bushing and cushion rubber for damage. If so, replace with new ones.

**Installation**

Tighten the bolts and nuts of engine suspension frame.

**Engine suspension frame nut:**  
**Torque Value: 4.5~5.5 kgf-m**

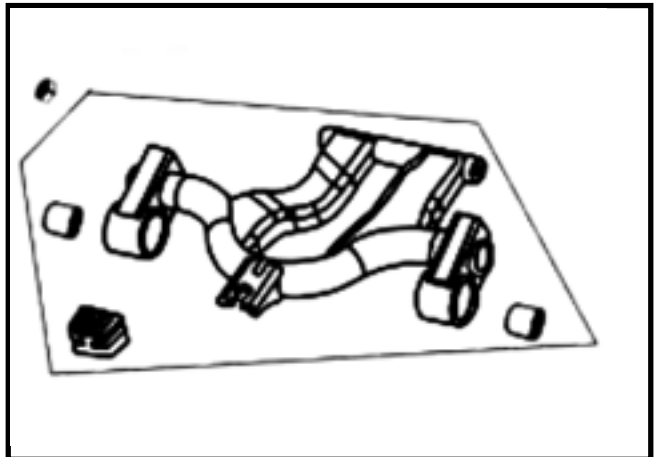

### INSTALLATION OF ENGINE

Check if the bushings of engine suspension frame and shock absorber for damaged. If so, replace with new ones.

Install the engine according to the reversing order of removal.

#### Caution

- Notice both feet and hands safety for squeezing as engine installation.
- Do not bent or squeeze each wires or hose.
- Route all cables and wires in accordance with the routine layout.

**Engine suspension nut:**

**Torque Value: 4.5~5.5kgf-m**

**Rear shock absorber bolt:**

**Torque Value: Top: 3.5~4.5kgf-m**

**lower: 2.4~3.0kgf-m**

**Rear wheel axle nut:**

**Torque Value: 11.0~13.0kgf-m**

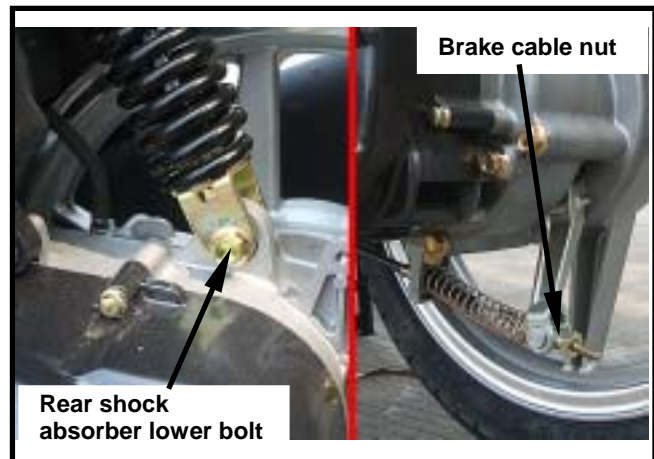

MECHANISM DIAGRAM .....6-1	CYLINDER HEAD INSPECTION..... 6-8
PRECAUTIONS IN OPERATION .....6-2	VALVE SEAT INSPECTION AND SERVICE 6-10
TROUBLE SHOOTING.....6-3	CYLINDER HEAD REASSEMBLY ..... 6-12
CAMSHAFT REMOVAL .....6-4	CYLINDER HEAD INSTALLATION ..... 6-13
CYLINDER HEAD REMOVAL .....6-6	CAMSHAFT INSTALLATION ..... 6-13
CYLINDER HEAD DISASSEMBLY ....6-7	VALVE CLEARANCE ADJUSTMENT ..6-14

**MECHANISM DIAGRAM**

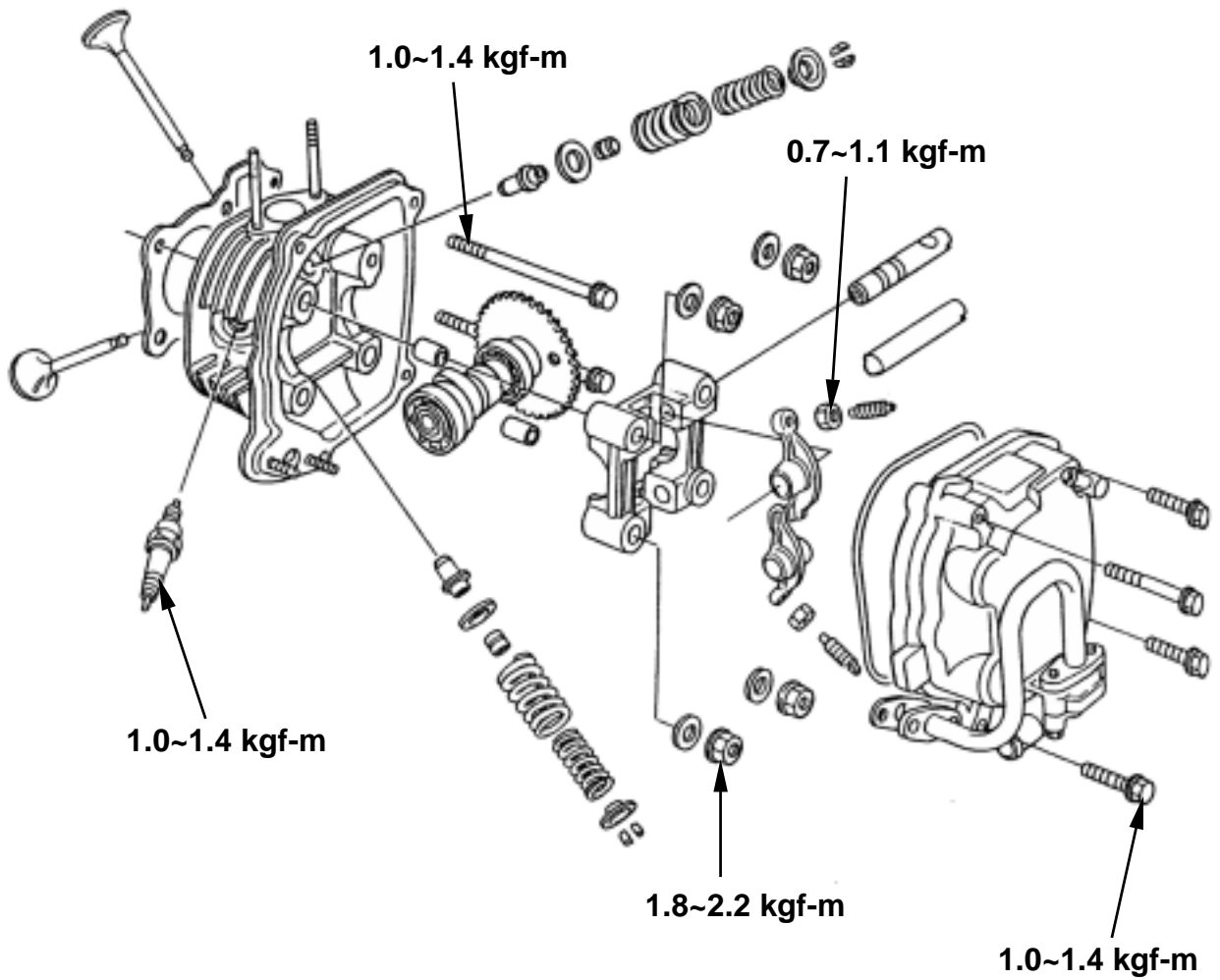

**PRECAUTIONS IN OPERATION****General Information**

- This chapter is contained maintenance and service for cylinder head, valve, and camshaft as well as valve rocker arm.
- Cylinder head service cannot be carried out when engine is in frame.

**Specification**

unit: mm

Item		Standard	Limit
Compression pressure		12 ± 2 kg/cm <sup>2</sup>	-
Camshaft	Height of cam lobe	Intake	25.736
		Exhaust	25.55
Rocker arm	ID of valve rocker arm		10.00
	OD of valve rocker arm shaft		10.00
Valve	OD of valve stem	Intake	5.00
		Exhaust	5.00
	OD of Guide		5.00
	Clearance between valve stem and guide	Intake	0.010~0.037
		Exhaust	0.030~0.057
	Free length of valve spring	Outer	32.56
		Inner	35.25
	Valve seat width		1.000
Connection Flatness of cylinder head		-	-

**Torque Value**

Cylinder head cover bolt	1.0~1.4kgf-m
Cylinder head bolt (LH)	1.0~1.4kgf-m
Cylinder head Nut	1.8~2.2kgf-m (apply with oil on bolt thread & seat)
Sealing bolt of timing chain auto-adjuster	0.8~1.2kgf-m
Bolt of timing chain auto-adjuster	1.0~1.4kgf-m
Timing gear cover bolts	0.7~1.1kgf-m (apply with oil on bolt thread & seat)
Spark plug	1.0~1.4kgf-m

**TOOLS****Special service tools**

Valve reamer: 5.0mm  
 Valve guide driver: 5.0mm  
 Valve spring compressor



**TROUBLE SHOOTING**

Engine performance will be effected by troubles on engine top end. The troubles usually can be determinate or by performing cylinder compression test and judging the abnormal noise generated.

**Rough Idle**

Low compression pressure.

**Low compression pressure****1. Valve**

- Improper valve adjustment.
- Burnt or bended valve.
- Improper valve timing.
- Valve spring damaged.
- Valve carbon.
- Poor sealing on valve seat.
- Improper spark plug installation.

**2. Cylinder head**

- Cylinder head gasket leaking or damage.
- Tilt or crack cylinder surface.

**3. Piston**

- Piston ring worn out.

**High compression pressure**

- Too much carbon deposit on combustion chamber or piston head.

**Noise**

- Improper valve clearance adjustment
- Burnt valve or damaged valve spring
- Camshaft wear out or damage
- Cam chain wear out or looseness
- Auto-adjuster wear out or damage of cam chain
- Camshaft sprocket wear out
- Rocker arm or rocker arm shaft wear out

**White smoke**

- Valve guide or valve stem wear out
- Valve stem seal wear out

### CAMSHAFT REMOVAL

Remove the shroud of the engine.  
 Remove the crankcase blow-by system hose from the cylinder head.  
 Remove the cylinder head bolts and then remove the cylinder head (4 bolts).

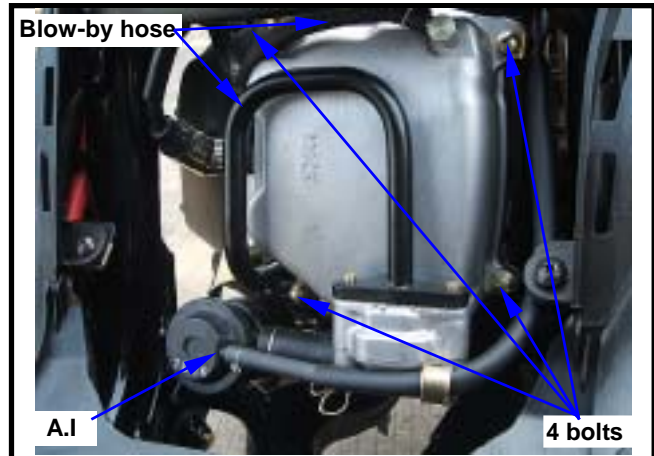

Loosen the screw of camshaft chain adjuster and remove O-ring.  
 With a flat screwdriver to tighten the screw of camshaft chain adjuster in a clockwise motion for release adjuster.

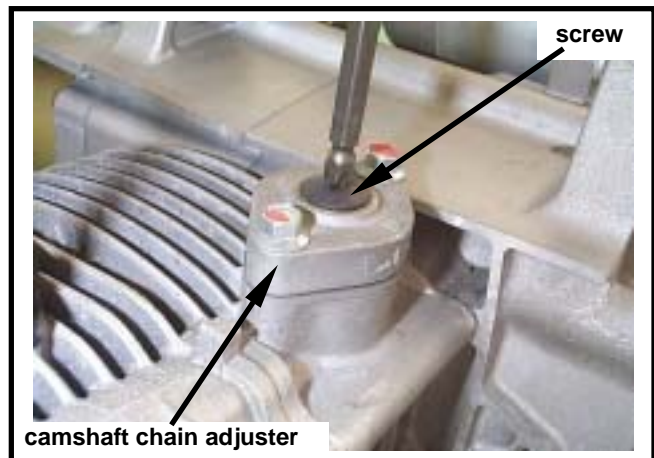

Turn the flywheel in counter clockwise motion with T type wrench until the "T" mark on flywheel aligned with the mark on the crankcase so that the hole on the camshaft sprocket is forward up and piston is at TDC position.

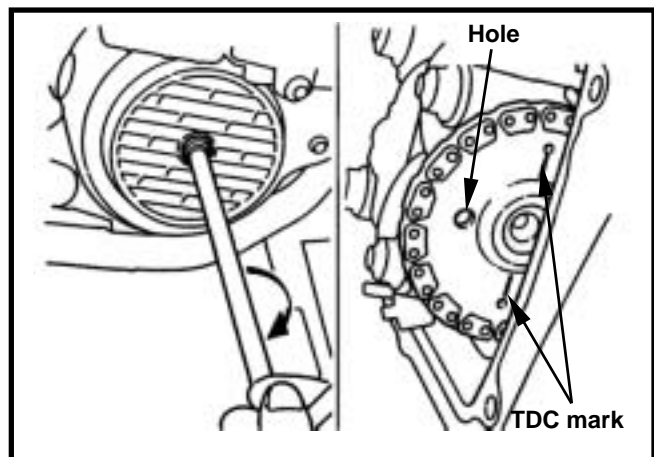

Remove camshaft holder nut and washer.

#### **Caution**

Loosen the nuts diagonally by 2-3 sequences.

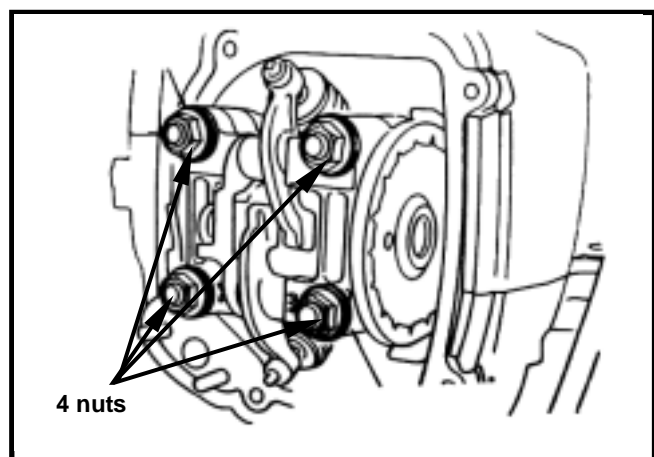

Remove the camshaft holder and rocker arm set.  
 Remove the camshaft chain from the camshaft sprocket.  
 Remove the camshaft.



**Camshaft Inspection**

Inspect cam lobe height for damaged.

**Service Limit**

**IN: Replacement when less than 25.29 mm**

**EX: Replacement when less than 25.12 mm**

Inspect the camshaft bearing for looseness or wear out. If any, replace whole set of camshaft and bearing.

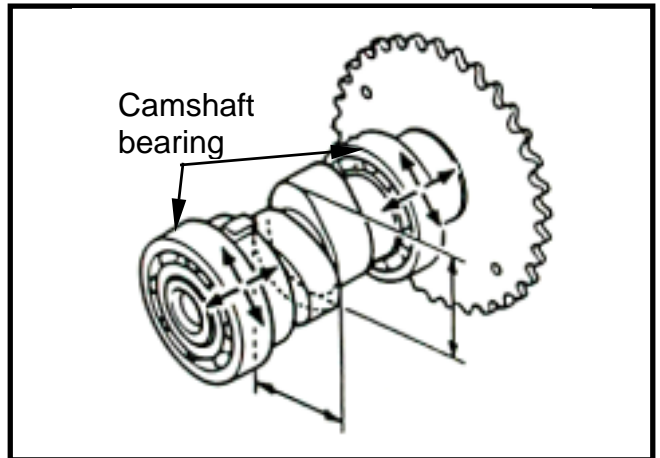

**Disassembly Of Camshaft Holder**

With a 5 mm bolt to screw in the cam rocker arm shaft so that take it out.  
 Remove cam rocker arm.

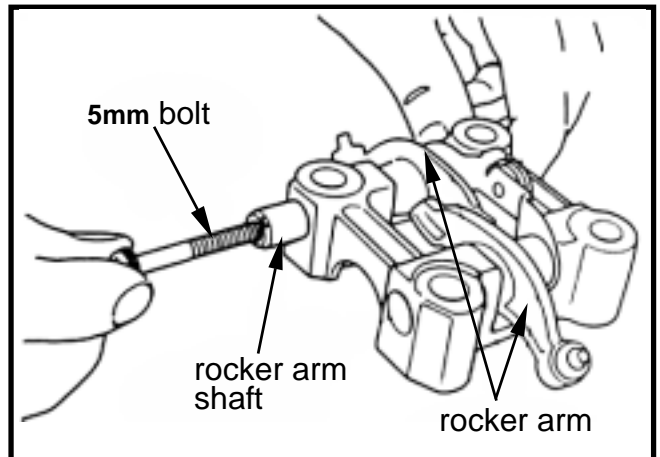

**Inspection Of Camshaft Holder**

Check if the camshaft holder, cam rocker arm and rock arm shaft for wearing out or damage.

**⚠ Caution**

- Further check is necessary if any wear is found on the moveable surface of cam rocker arm.
- Check if the camshaft bearing mounting surface for wear or damage.

Measure the cam rocker arm I.D. of the camshaft holder.

**Service Limit: Replace when it is above 12.10 mm**

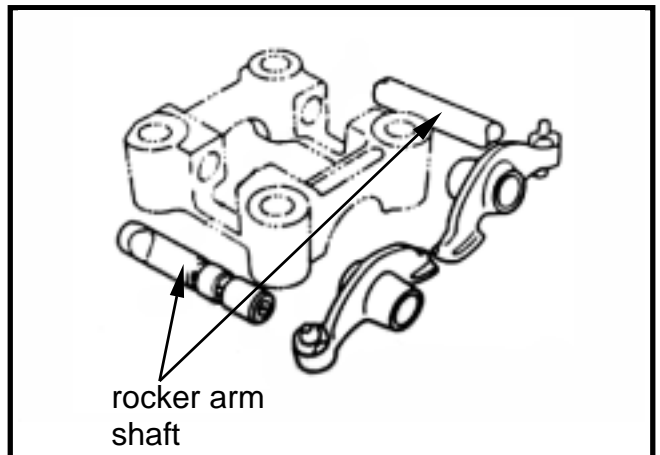

Measure the valve rocker arm I.D.

**Service Limit: Replace when it is above 10.100 mm**



Measure the active O.D. of the valve rocker arm shaft and valve rocker arm.

**Service Limit: Replace when it is above 9.910 mm**

Calculate the clearance between the rocker arm shaft and the rocker arm.

**Service Limit: Replace when it is above 0.10 mm**

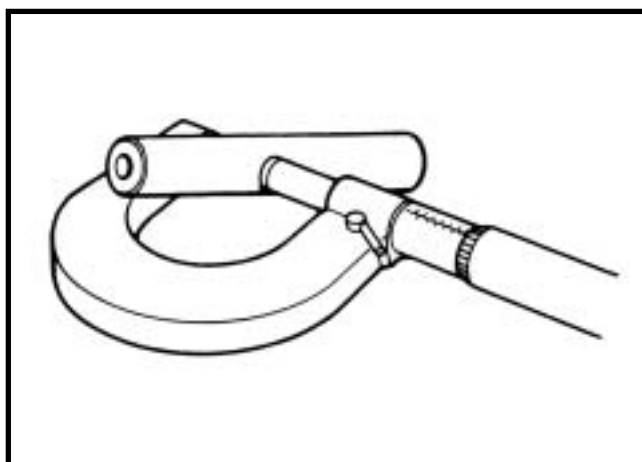

### CYLINDER HEAD REMOVAL

Remove double seat, luggage box and front center cover.

Remove the engine (refer to Chapter 5).

Remove the cooling fan cover.

Remove the engine shroud (4 bolts).



Remove the camshaft (refer to page 6-4).



Remove the 2 cylinder head mounting bolts from cylinder head left side cover.  
 Remove cylinder head gasket and 2 dowel pins.  
 Remove chain plate.  
 Clean up residues from the matching surfaces of cylinder and cylinder head.

**⚠ Caution**

- Do not damage the matching surfaces of cylinder and cylinder head.
- Avoid residues of gasket or foreign materials falling into crankcase as cleaning.

**CYLINDER HEAD DISASSEMBLY**

Use a valve compressor to press the valve spring.

After removed valve cotters, release the compressor and then take out spring retainer, valve spring and valves.

**⚠ Caution**

- In order to avoid to losing spring tension, do not compress the spring too much. Its length is based on the installation of latch.

Special Service Tool: Valve spring compressor.

Remove valve stem guide seal.  
 Clean carbon deposits in combustion chamber.  
 Clean residues and foreign materials on cylinder head matching surface.

**⚠ Caution**

- Do not damage the matching surface of cylinder head.

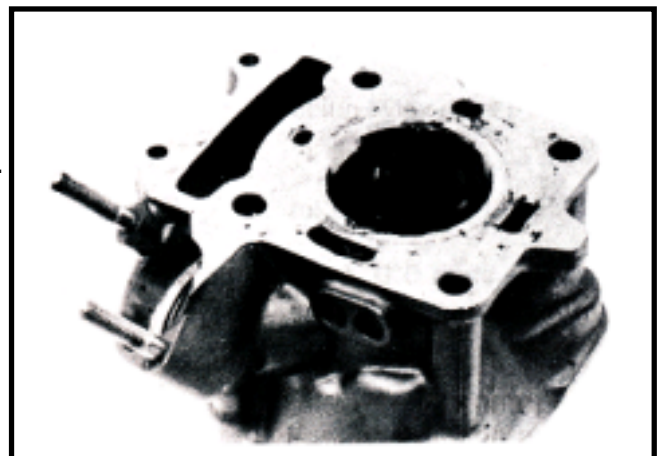
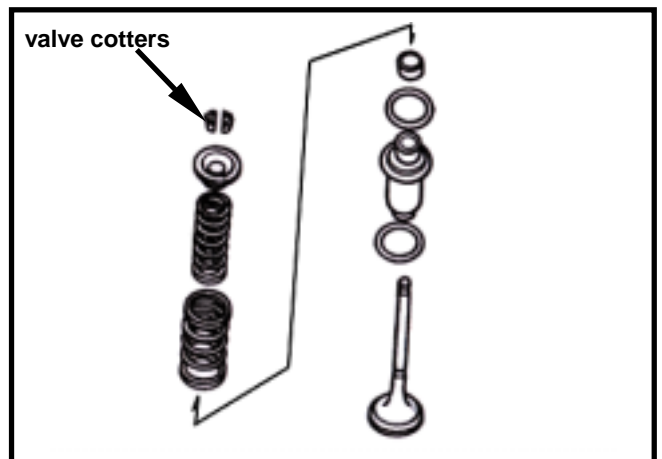
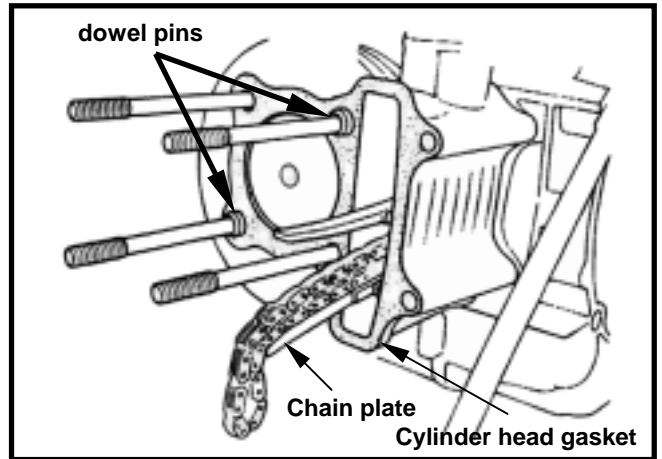

## CYLINDER HEAD INSPECTION

Check if spark plug and valve holes are crack.  
Measure cylinder head flat with a straightedge and flat feeler gauge.

**Service limit: 0.5mm**

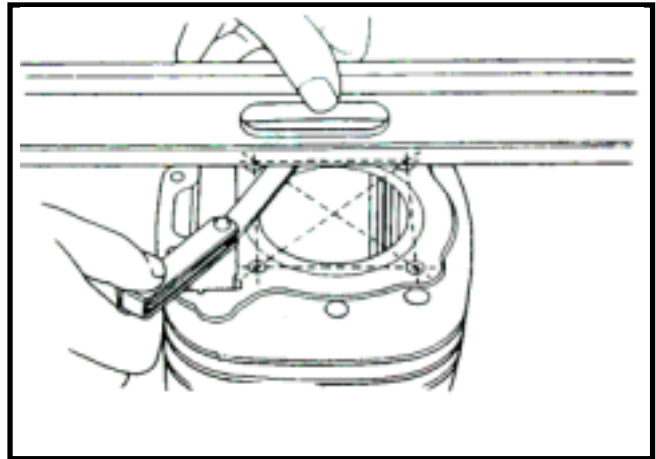

### Valve spring free length

Measure the free length of intake and exhaust valve springs.

**Standard**

**Outer : 35.250 mm**

**Inner : 32.410 mm**

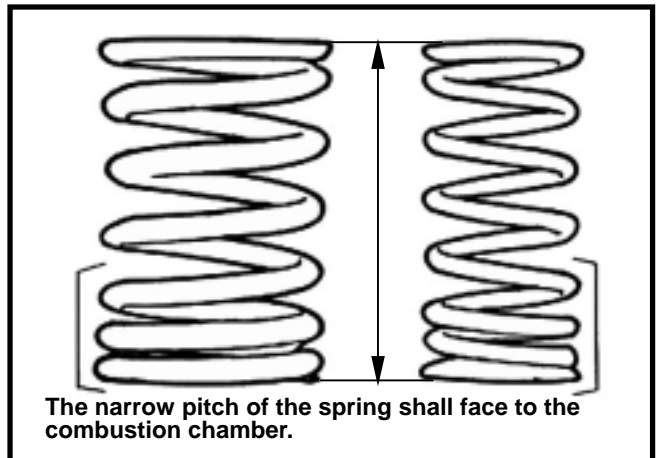

### Valve stem

Check if valve stems are bend, crack or burn.  
Check the operation condition of valve stem in valve guide, and measure & record the valve stem outer diameter.

**Service Limit: IN 4.900mm**

**EX 4.900mm**

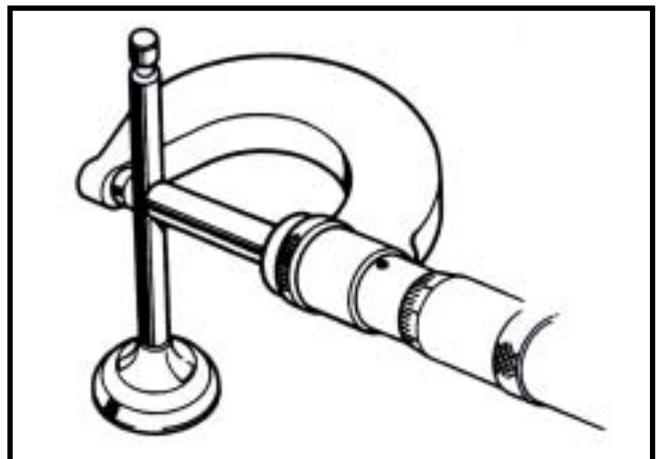

### Valve guide

**⚠ Caution**

Before measuring the valve guide, clean carbon deposits with reamer.

Special Service Tool: 5.0mm valve guide reamer

Measure and record each valve guide inner diameters.

**Service limit: 5.030mm**

The difference that the inner diameter of valve guide deducts the outer diameter of valve stem is the clearance between the valve stem and valve guide.

**Service Limit: IN 0.08mm**

**EX 0.10mm**

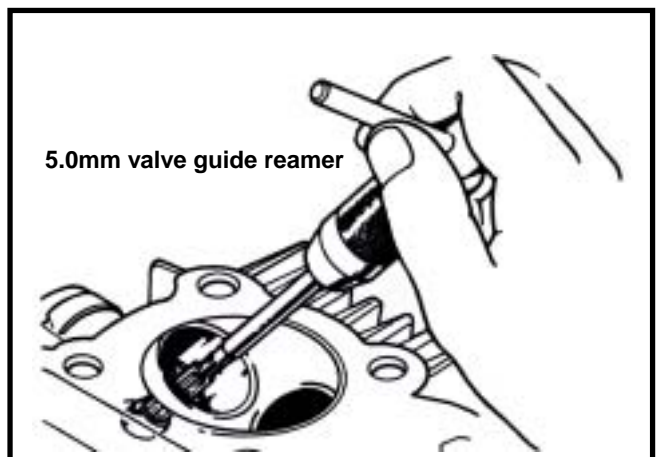

**⚠ Caution**

If clearance between valve stem and valve guide exceeded service limit, check whether the new clearance that only replaces new valve guide is within service limit or not. If so, replace valve guide.

Correct it with reamer after replacement.  
If clearance still exceeds service limit after replaced valve guide, replace valve stem too.

**⚠ Caution**

It must correct valve seat when replacing valve guide.

**Valve guide replacement**

Heat up cylinder head to 100~150 with heated plate or toaster.

**⚠ Caution**

- Do not let torch heat cylinder head directly. Otherwise, the cylinder head may be deformed as heating it.
- Wear on a pair of glove to protect your hands when operating.

Hold the cylinder head, and then press out old valve guide from combustion chamber side.

**Tool: Valve guide driver 5 mm**

**⚠ Caution**

- Check if new valve guide is deformation after pressed it in.
- When pressing in the new valve guide, cylinder head still must be kept in 100~150 .

Adjust the valve guide driver and let valve guide height is in 13mm.  
Press in new valve guide from rocker arm side.

**Tool: Valve guide driver 5 mm**

Wait for the cylinder head cooling down to room temperature, and then correct the new valve guide with reamer.

**⚠ Caution**

- Using cutting oil when correcting valve guide with a reamer.
- Turn the reamer in same direction when it be inserted or rotated.

Correct valve seat, and clean up all metal residues from cylinder head.

**Special tool: Valve guide reamer 5 mm**

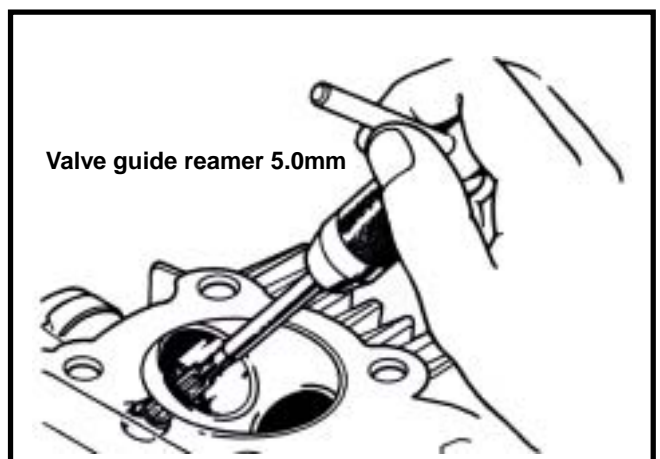
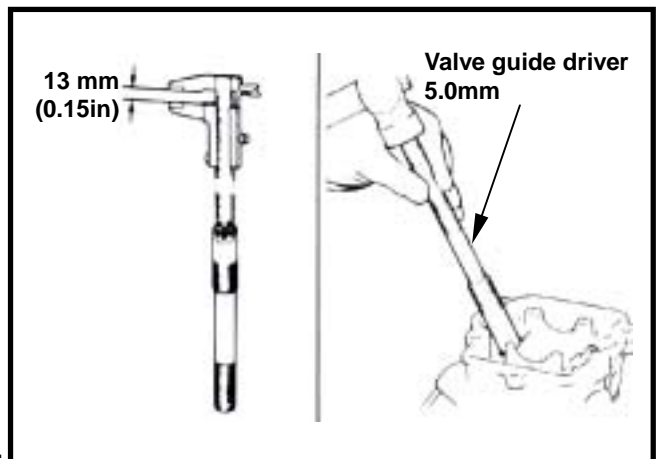
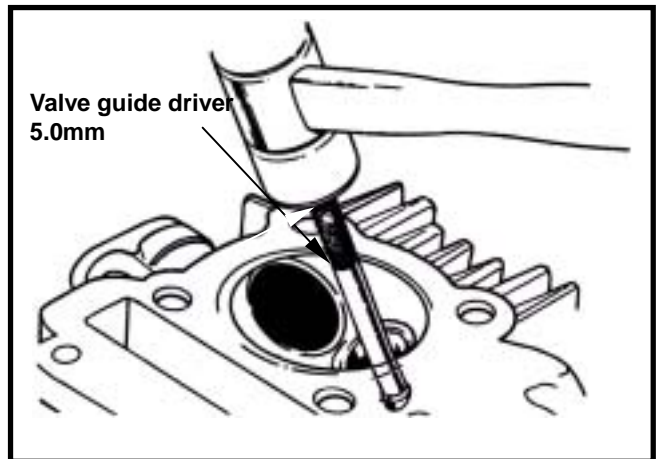
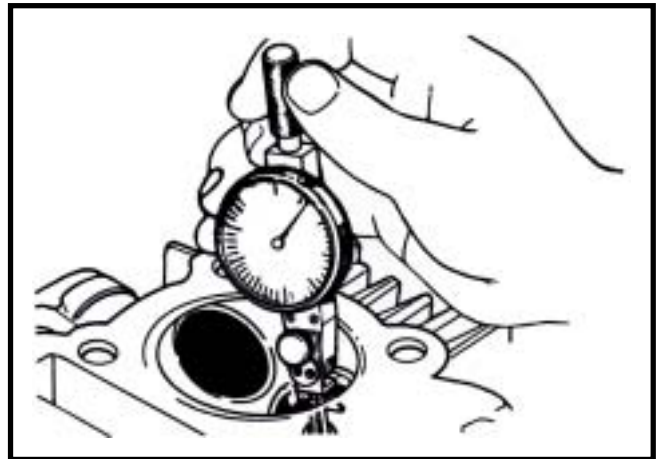

### VALVE SEAT INSPECTION AND SERVICE

Clean up all carbon deposits onto intake and exhaust valves.

Apply with emery slightly onto valve contact face. Grind valve seat with a rubber hose or other manual grinding tool.

**⚠ Caution**

- Do not let emery enter into between valve stem and valve guide.
- Clean up the emery after corrected, and apply with red paint onto contact faces of valve and valve seat.

Remove the valve and check its contact face.

**⚠ Caution**

Replace the valve with new one if valve seat is roughness, wear out, or incomplete contacted with valve seat. If the valve and the valve seat still can not be matched sealing after grinded, replace it with new one.

#### Valve seat inspection

If the valve seat is too width, narrow or rough, correct it.

#### Valve seat width

**Service limit: 1.6mm**

Check the contact condition of valve seat.

#### Valve seat grinding

The worn valve seat has to be grinded with valve seat chamfer cutter.

Use 45° valve seat chamfer cutter to cut any rough or uneven surface from valve seat.

**⚠ Caution**

After valve guide had been replaced, it has to be grinded with 45° valve seal chamfer cutter to correct its seat face.

Use 32° cutter to cut a quarter upper part out.

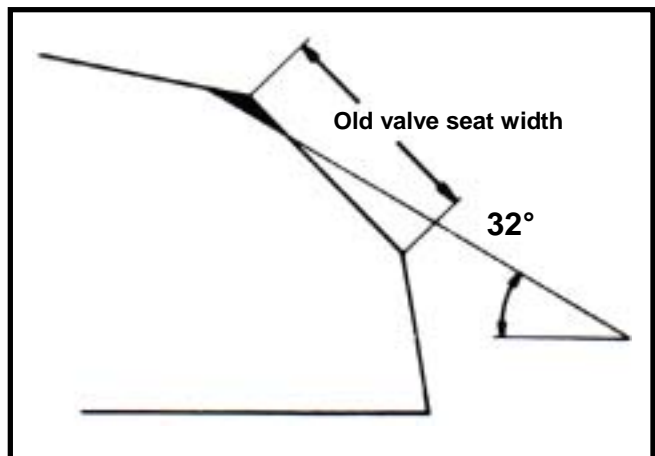
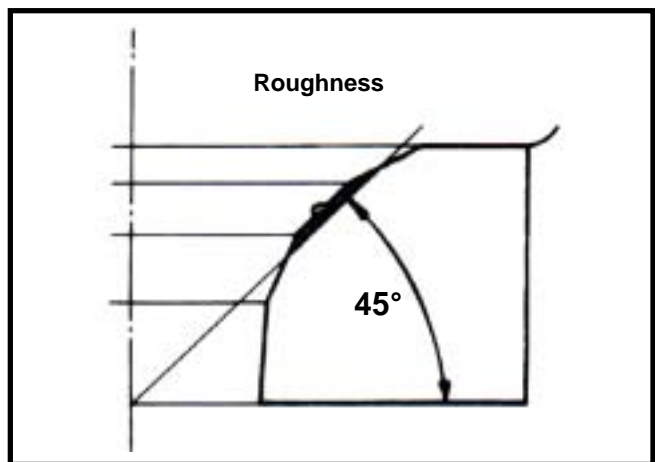
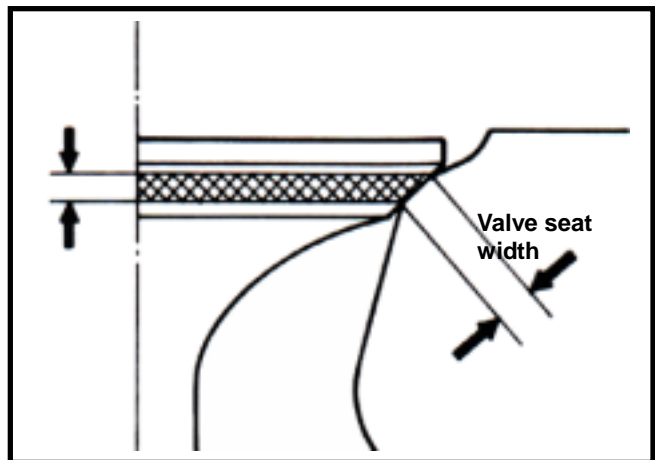
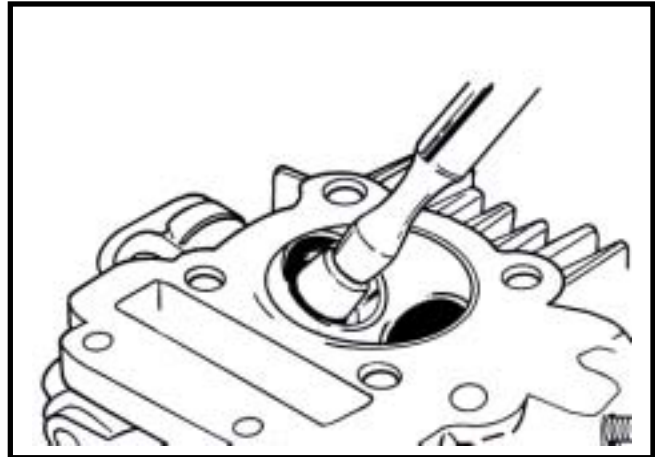



Use 60° cutter to cut a quarter lower part out. Remove the cutter and check new valve seat.

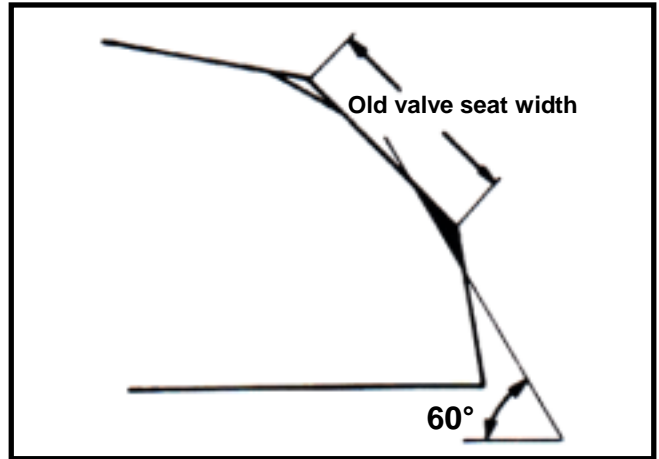

Use 45° cutter to grind the valve seat to specified width.

**⚠ Caution**

Make sure that all roughness and uneven faces had been grinded.

Grind valve seat again if necessary.

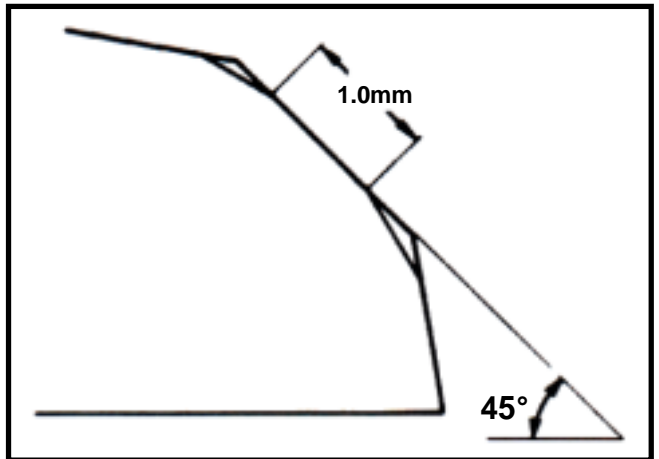

Coat the valve seat surface with red paint. Install the valve through valve guide until the valve contacting with valve seat, slightly press down the valve but do not rotate it so that a seal track will be created on contact surface.

**⚠ Caution**

The contact surfaces of valve and valve seat are very important to the valve sealing capacity.

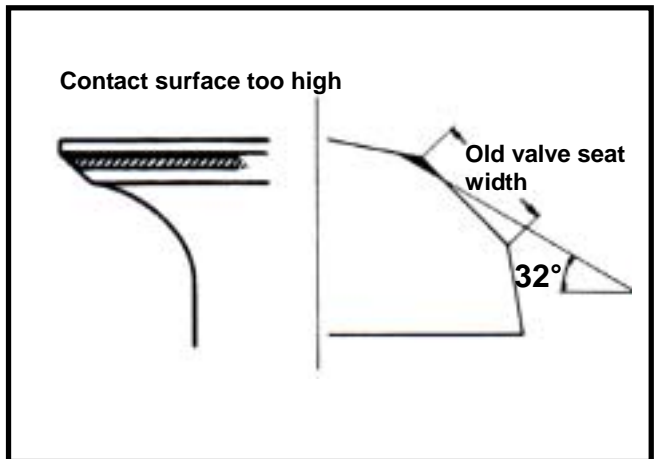

If the contact surface too high, grind the valve seat with 32° cutter. Then, grind the valve seat with 45° cutter to specified width.

If the contact surface too low, grind the valve seat with 60° cutter. Then, grind the valve seat with 45° cutter to specified width.

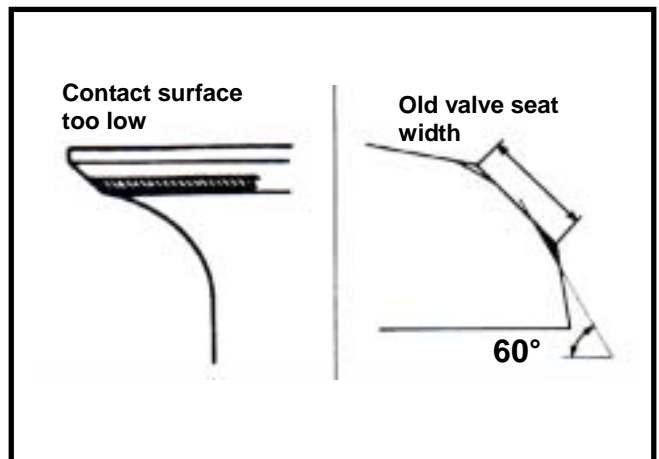

After the valve seat grinded, coat valve seat surface with emery and then slightly press the grinded surface.  
Clean up all emery coated onto cylinder and valve after grinded.

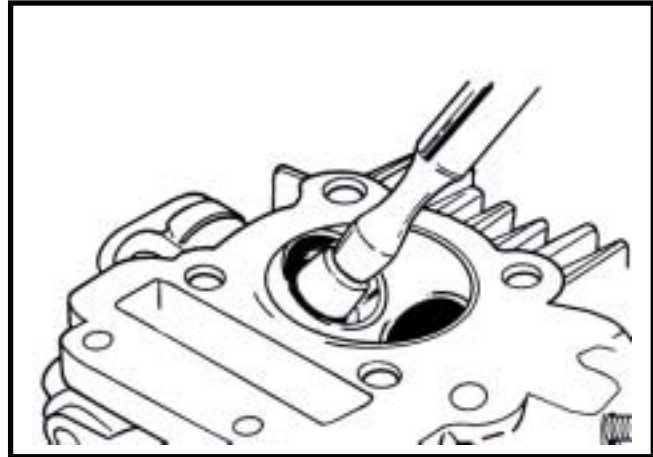

### CYLINDER HEAD REASSEMBLY

Lubricate valve stem with engine oil, and then insert the valve into valve guide.  
Install new valve stem oil seal.  
Install valve springs and retainers.

#### Caution

The closed coils of valve spring should face down to combustion chamber.

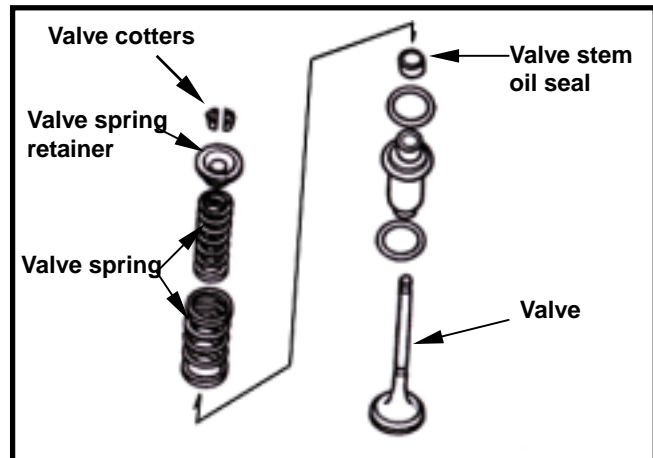

Use valve spring compressor to press valve spring.  
Install valve split locks and release the valve compressor.

#### Caution

In order to avoid to losing spring tension, do not compress the spring too much. Its length is based on the installation of latch.

Special tool: valve spring compressor



Tap valve stem to make valve retainer and valve stem sealing properly.

#### Caution

Place and hold cylinder head on to working table so that can prevent from valve damaged.

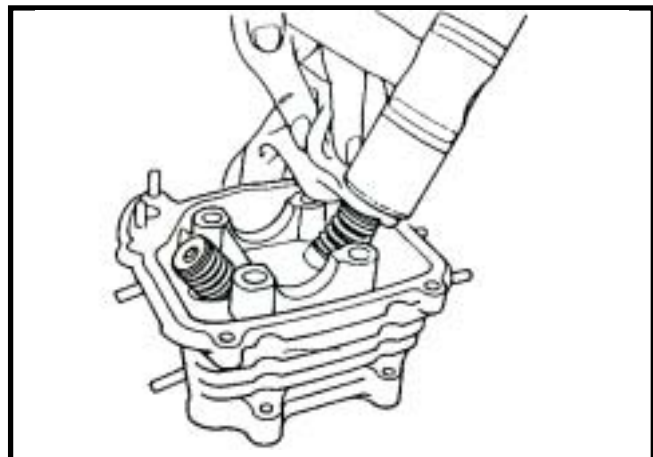

**CYLINDER HEAD INSTALLATION**

Install the lock pins and new cylinder head gasket onto the cylinder head.  
Install the camshaft chain plate.

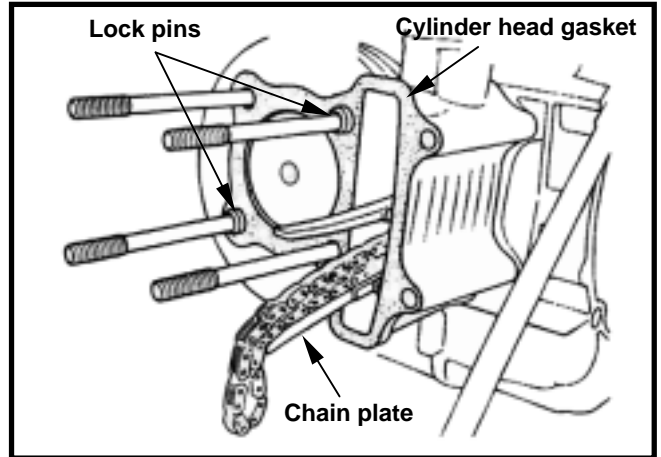

Install the cylinder head.

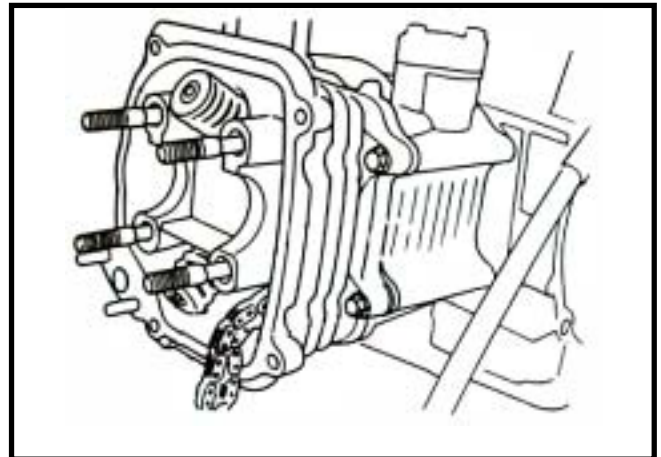

**CAMSHAFT INSTALLATION**

Assemble the camshaft holder.  
Install the exhaust valve rocker arm set onto the camshaft holder showing "EX" mark.  
Install intake valve rocker arm and rocker arm shaft.

**⚠ Caution**

The tangent of rocker shaft of intake valve should match with the bolt hole of camshaft mounting seat.

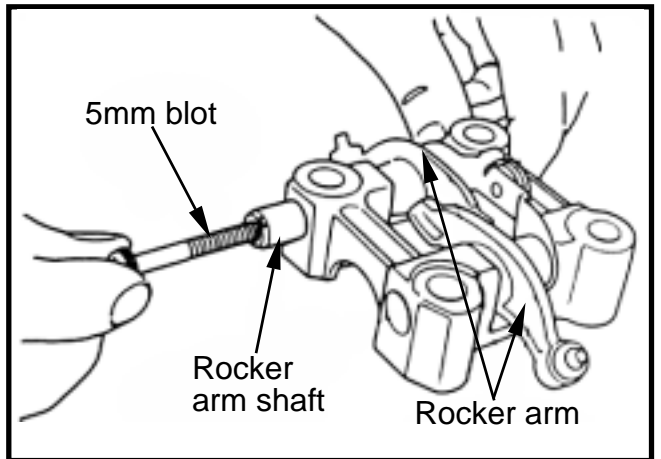

With T type wrench to turn crankshaft in a clockwise motion so that the "T" mark on the flywheel aligns with the mark on crankcase. (piston is at TDC position)  
Place the TDC marks of the cam sprocket at same level of the top-end of cylinder head.  
The other single hole of the cam sprocket is in upward. Then, install the cam chain onto the cam sprocket.

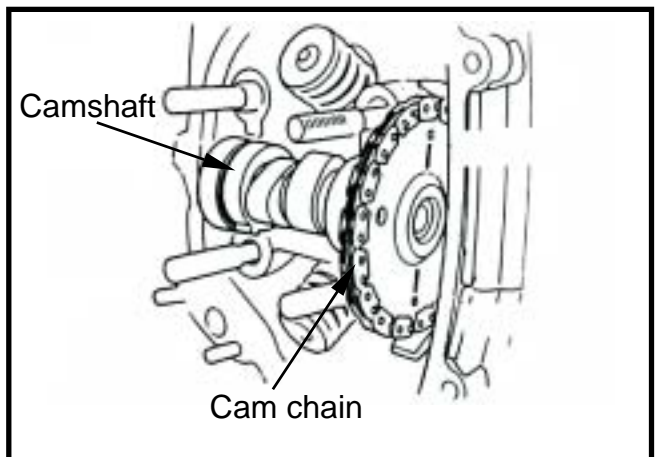

Install the lock pins.

Install the camshaft holder, gasket and nut onto the cylinder head.

Tighten the cylinder head nuts. (4 nuts)

At first, tighten the 4 nuts on the cylinder top and then tighten the 2 bolts on the left side of cylinder head.

**Torque value: 1.8~2.2 kgf-m**

Install the spark plug and tighten it.

**Torque value: 1.0~1.2 kgf-m**

**⚠ Caution**

- Apply with oil onto the thread of cylinder head bolts and tighten the bolts in diagonally for 2-3 sequences.
- Do not over tightening the bolts to avoid the cylinder head deformation, noise created or leaking so that effects motorcycle's performance.

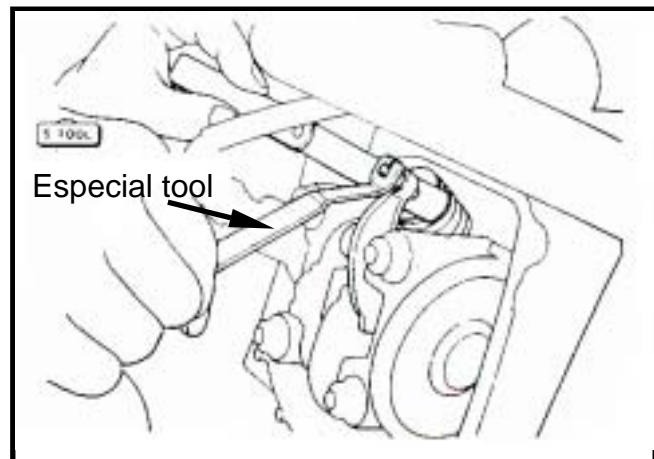
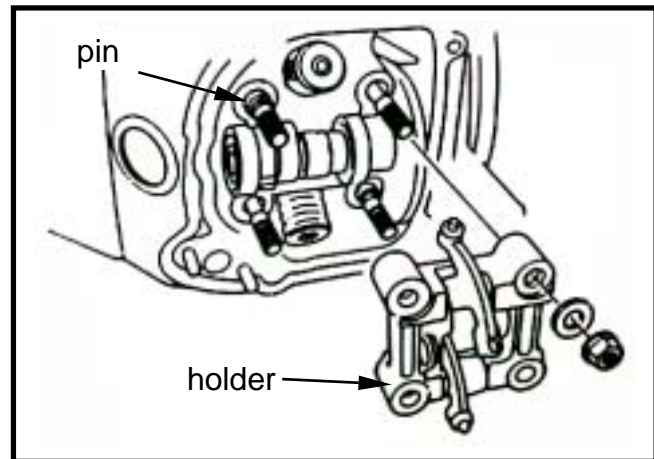

### VALVE CLEARANCE ADJUSTMENT

Loosen valve clearance adjustment nuts and bolts located on valve rocker arm.

Measure and adjust valve clearance with feeler gauge.

After valve clearance had been adjusted to standard value, hold adjustment bolt and then tighten the adjustment nut.

**Standard Value: 0.12 ± 0.02mm**

With flat screwdriver, turn the cam sprocket adjuster in counter-clockwise motion so that the adjuster is pushed out to contact the cam chain plate tightly. Apply with oil onto a new O-ring and then install it onto the adjuster hole. Tighten the bolt cap of the adjuster adjustment hole.

**⚠ Caution**

The O-ring must be installed into glove.



Replace the O-ring of the cylinder head with new one. Install the cylinder head.

Tighten the cylinder head lock bolts.

Connect the blow-by hose onto the cylinder head.

Tighten the 2<sup>nd</sup> air injection (AI) nut.

Install the engine onto the engine frame.  
(Refer to Chapter 5)



MECHANISM DIAGRAM .....7-1	PISTON REMOVAL.....7-5
PRECAUTIONS IN OPERATION .....7-2	PISTON RING INSTALLATION.....7-7
TROUBLE DIAGNOSIS.....7-2	PISTON INSTALLATION.....7-8
CYLINDER REMOVAL .....7-3	CYLINDER INSTALLATION..... 7-8

**MECHANISM DIAGRAM**

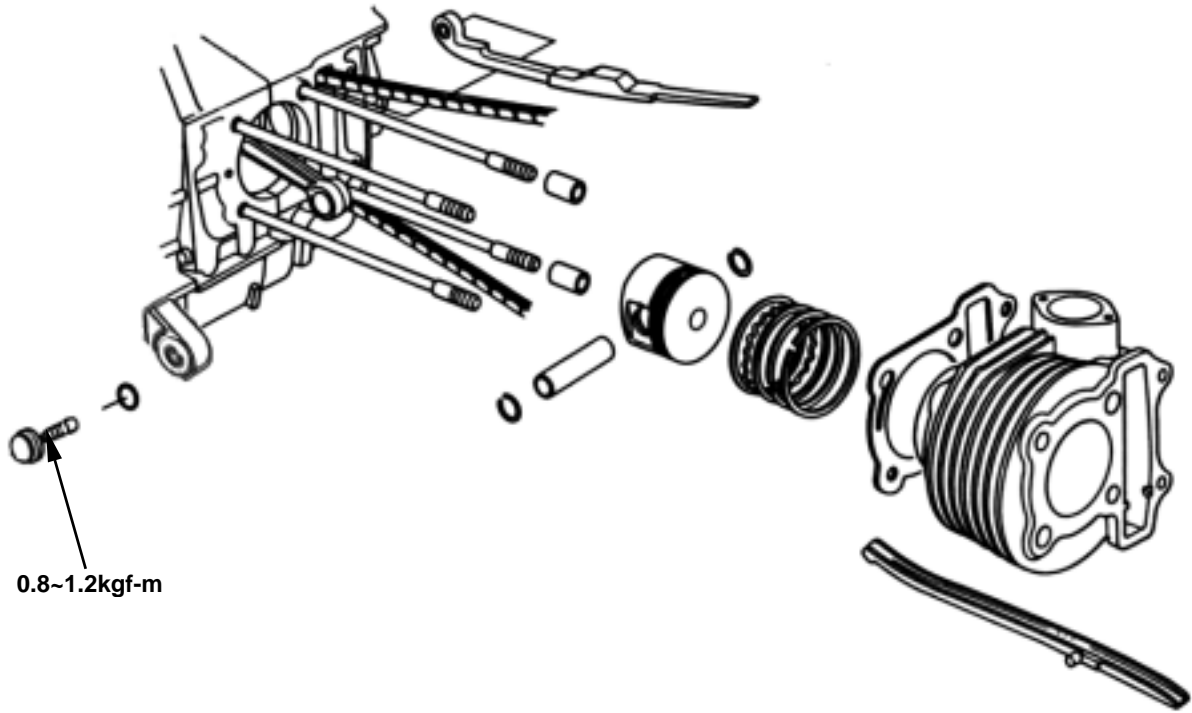

## PRECAUTIONS IN OPERATION

## General Information

- Both cylinder and piston service cannot be carried out when engine mounted on frame.

## Specification

unit: mm

Item		Standard	Limit	
Cylinder	ID	39.00	-	
	Bend/wrap age	-	0.050	
	Roundness	0.005	0.050	
	Cylindrical	0.005	0.030	
Piston/ Piston ring	Clearance between piston rings	Top ring	0.025~0.060	0.090
		2 <sup>nd</sup> ring	0.015~0.050	0.090
	Ring-end gap	Top ring	0.200~0.400	0.500
		2 <sup>nd</sup> ring	0.250~0.400	0.650
		Oil ring	0.200~0.700	-
	OD of piston		38.970~38.990	-
	Piston OD measurement position		Lower-end up 5mm of piston skirt	-
	Clearance between piston and cylinder		0.025~0.040	0.100
	ID of piston pin hole		13.002~13.008	13.040
OD of piston pin		13.000	12.994~13.000	
Clearance between piston and piston pin		0.002~0.014	0.020	
ID of connecting rod small-end		13	13.005~13.020	

## TROUBLE DIAGNOSIS

**Low Or Unstable Compression Pressure**

Cylinder or piston ring worn out.  
Compress pressure to high.  
Too much carbon deposited in combustion chamber and piston.

**Knock or Noise**

Cylinder or piston ring worn out.  
Carbon deposits on cylinder head top-side.  
Piston pin hole and piston pin wear out.

**Smoking in Exhaust Pipe**

Piston or piston ring worn out.  
Piston ring installation improperly.  
Cylinder or piston damage.

**Engine Overheat**

Carbon deposits on cylinder head top side.

**CYLINDER REMOVAL**

Remove cylinder head. (refer to chapter 6)  
Remove 2 bolts and then take out the cam chain auto-adjuster.

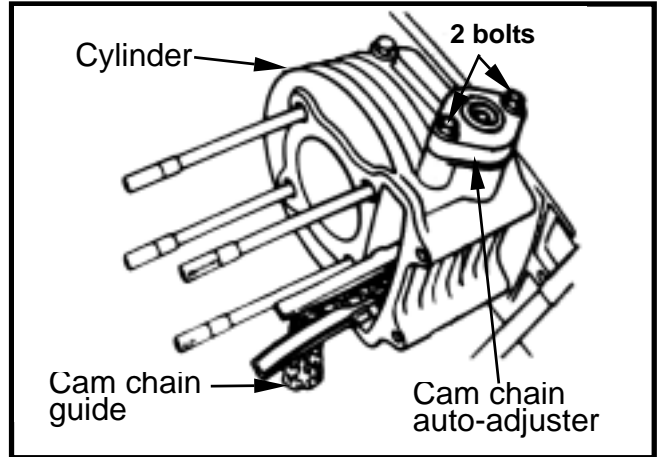

Remove cam chain plate.  
Remove cylinder.



Remove cylinder gasket and lock pins

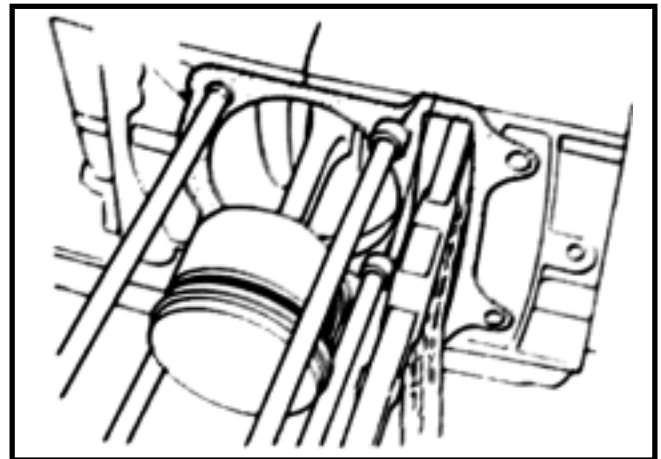

Clean the residues attached onto the matching surfaces of cylinder and crankcase.

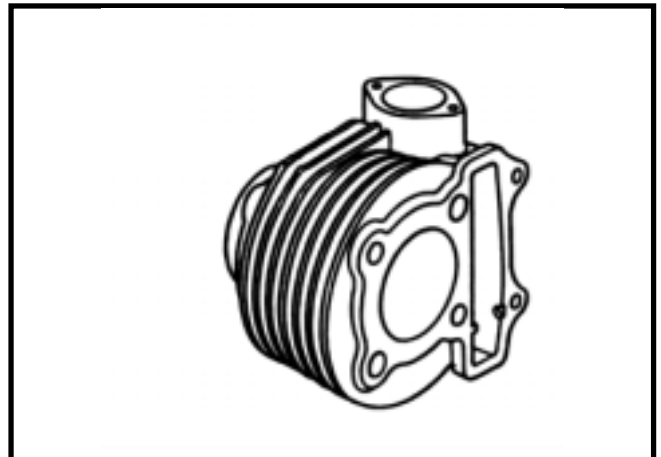

Cover the holes of crankcase and cam chain with a piece of cleaning cloth.  
 Clean up all residues or foreign materials from the two matching surfaces of cylinder and crankcase.

**⚠ Caution**

To soap the residues into solvent so that the residues can be removed more easily.

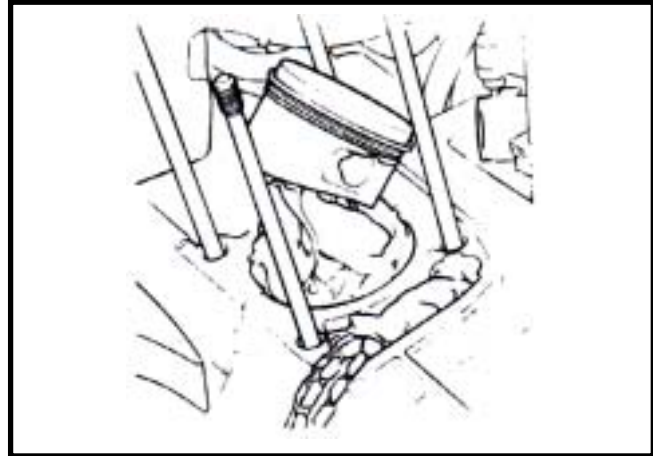

**INSPECTION**

Check if the inner diameter of cylinder is worn out or damaged.  
 In the 3 positions (top, center and bottom) of cylinder, measure the X and Y direction values respective in the cylinder.

**Service limit: 52.50mm**

Calculate both the real roundness (the difference between X and Y motion values) and the cylindrical roundness (the difference in the top, center or bottom positions of X or Y motion values.). Then, determinate by the max. value.

**Service limit**

**Real roundness: correct or replace as over 0.05 mm**

**Cylindrical roundness: correct or replace as over 0.05 mm**

Check Cylinder flat.

**Service limit: correct or replace as over 0.05 mm**

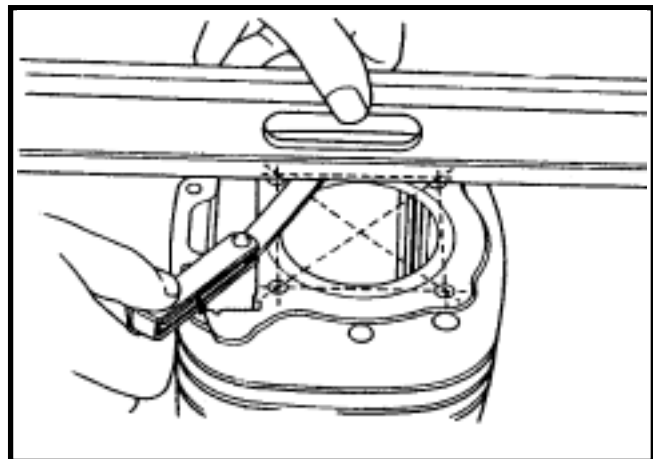
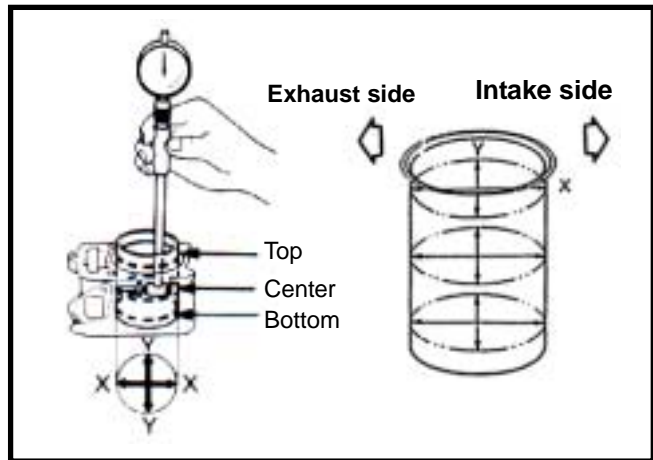



**PISTON REMOVAL**

Plug crankcase opening with a cleaning cloth to prevent from piston pin snap ring or other parts falling into crankcase when disassembling.

Hold another snap ring with pliers.

Push out the piston pin from the side that not removed the snap ring.

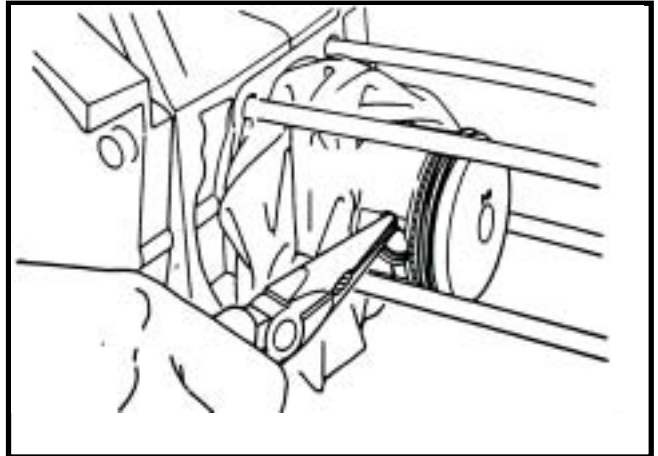

Remove piston rings.

**⚠ Caution**

Pay attention to remove piston rings because they are fragile.

Disassemble the piston rings.  
 Check if the piston rings are damaged or its grooves are worn.  
 Cleaning the carbon in piston ring grooves.

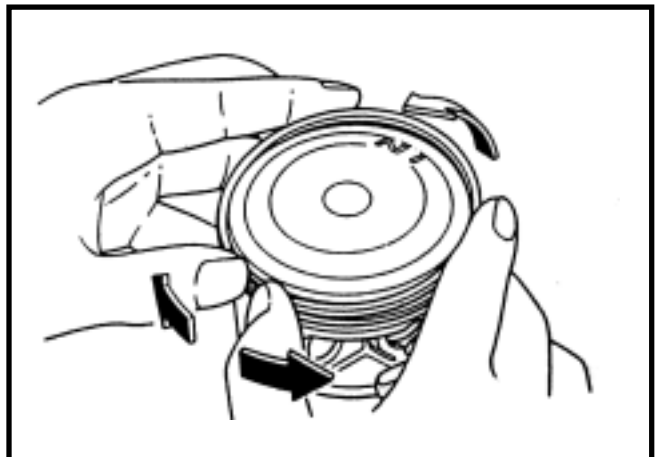

Install the piston rings and then measure clearance between piston ring and its grooves.

**Service Limit: Top ring: replace if over 0.09mm**  
**2nd ring: replace if over 0.09mm**

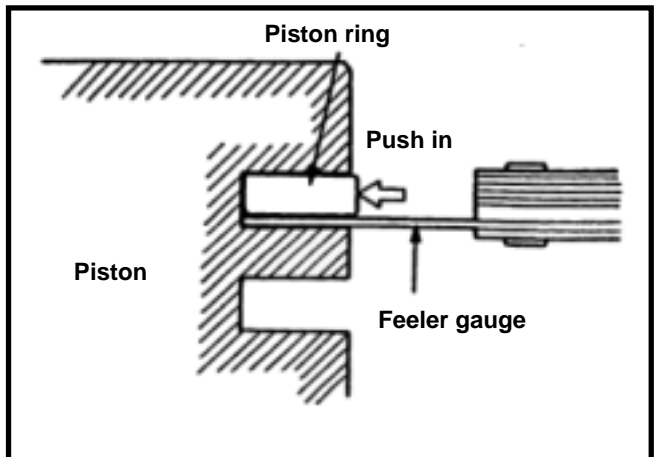

Take out the piston rings and place them respective into cylinder below 20mm of cylinder top. Measure each piston ring gaps.

**⚠ Caution**

Push the piston rings into cylinder with piston top-end in parallel motion.

**Service Limit: Top ring: replace if over 0.50mm**  
**2nd ring: replace if over 0.650mm**

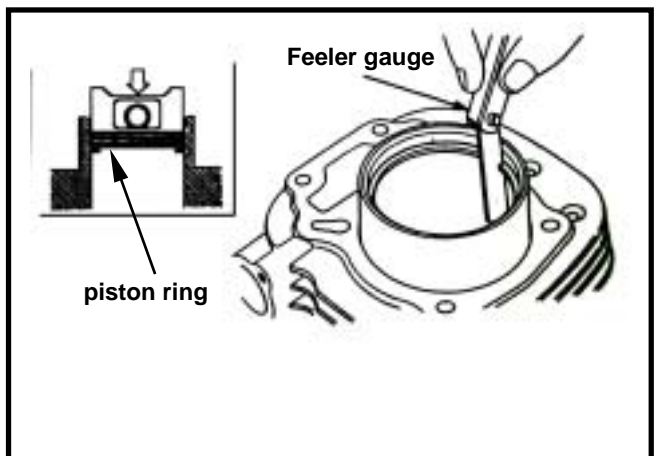

Measure the outer diameter of piston pin.  
**Service Limit: 12.994mm**

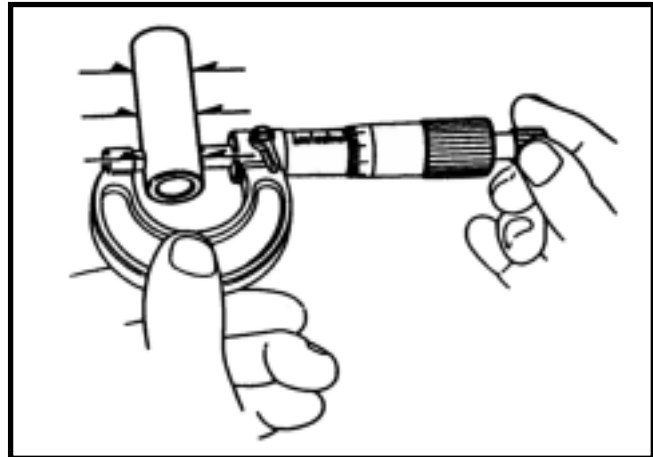

Measure the inner diameter of connecting rod small end.  
**Service Limit: 13.020mm**

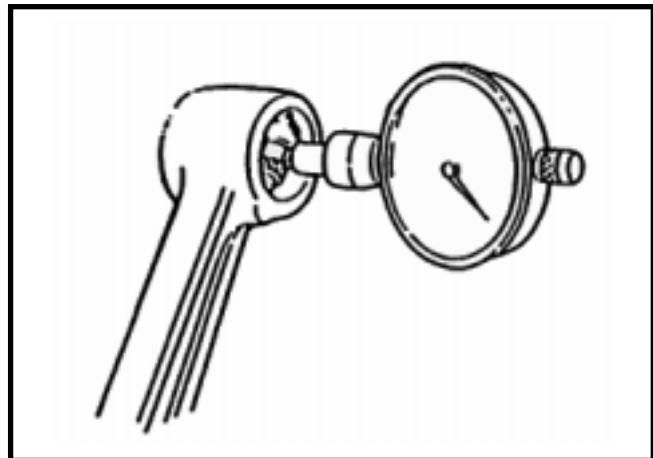

Measure the inner diameter of piston pin hole.  
**Service Limit: 13.040mm**

Calculate clearance between piston pin and its hole.  
**Service Limit: 0.02mm**

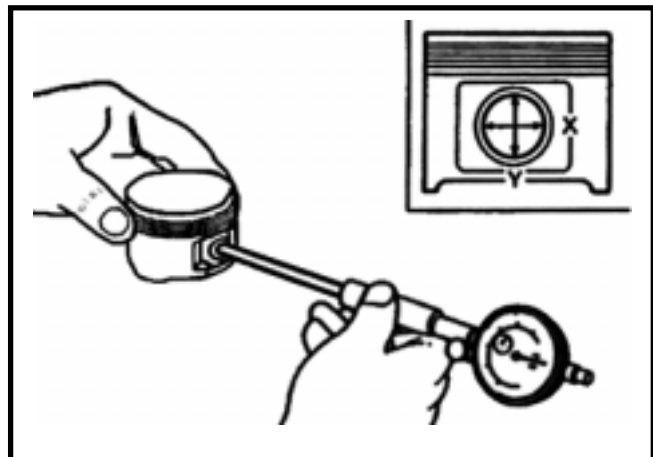

Measure piston outer diameter.

**⚠ Caution**

The measurement position is 10 mm distance from piston bottom side, and 90° to piston pin.

**Service limit: 38.970mm**

Compare measured value with service limit to calculate the clearance between piston and cylinder.

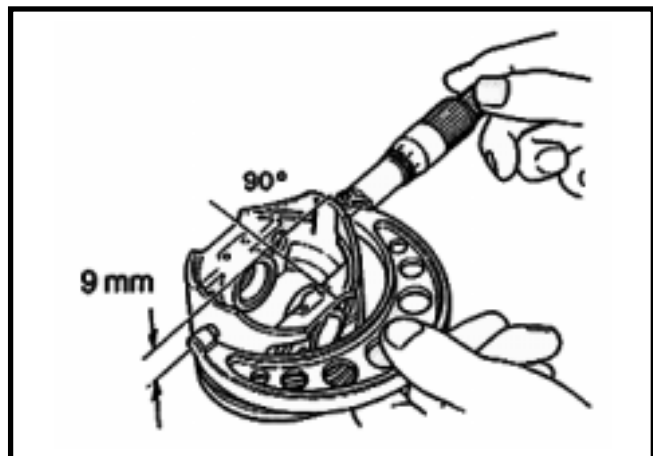

**PISTON RING INSTALLATION**

Clean up piston top, ring groove, and piston skirt.  
Install the piston ring onto piston carefully.  
Place the openings of piston ring as diagram shown.

**⚠ Caution**

- Do not damage piston and piston rings as installation.
- All marks on the piston rings must be forwarded to up side.
- Make sure that all piston rings can be rotated freely after installed.

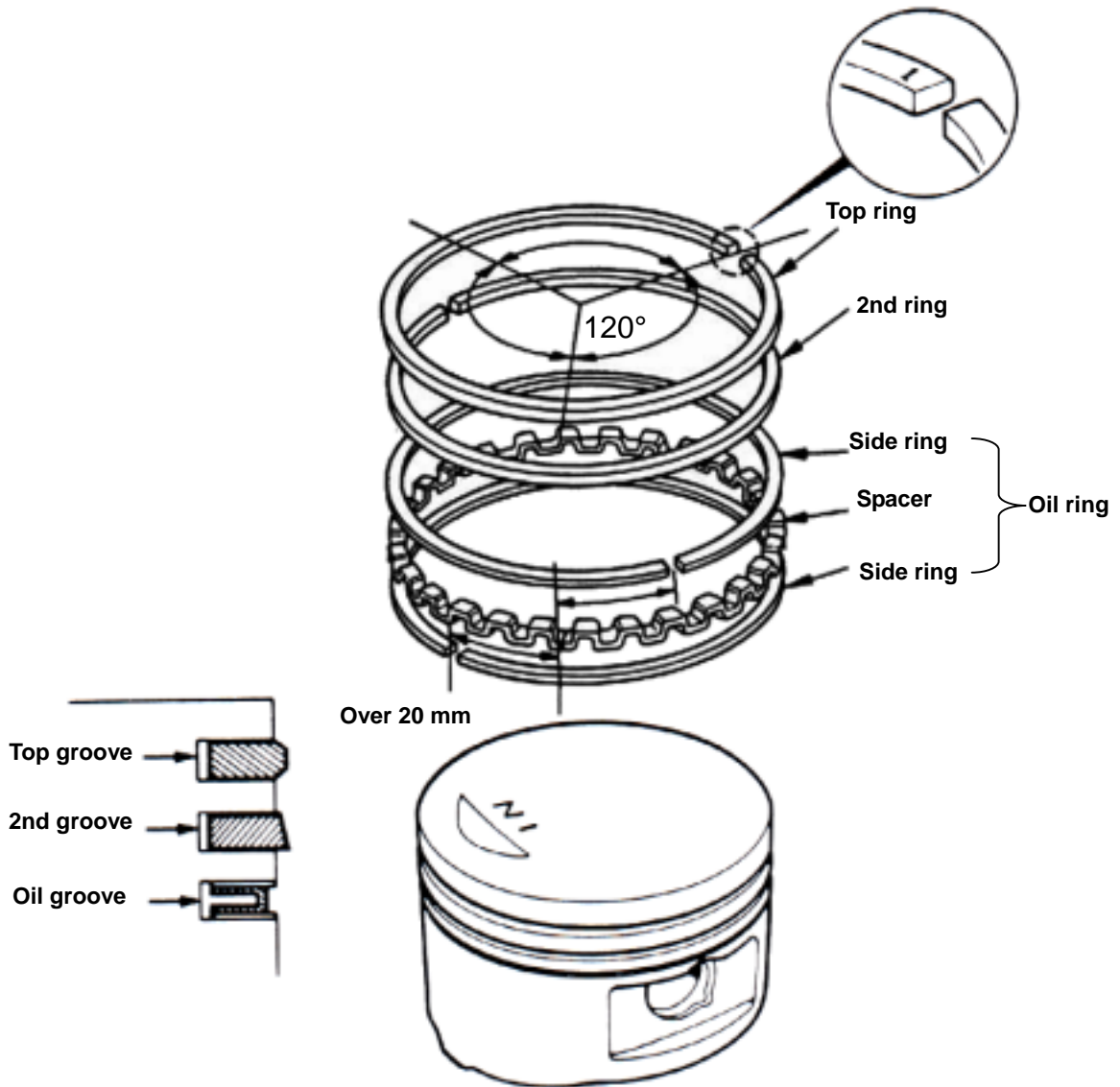

**PISTON INSTALLATION**

Install piston and piston pin, and place the IN mark on the piston top side forward to intake valve.

Install new piston pin snap ring.

**⚠ Caution**

- Do not let the opening of piston pin snap ring align with the opening piston ring.
- Place a piece of cleaning cloth between piston skirt section and crankcase in order to prevent snap ring from falling into crankcase as operation.

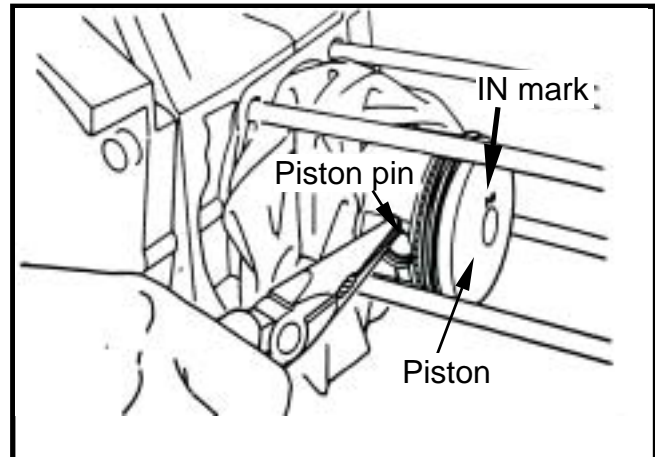
**CYLINDER INSTALLATION**

Clean up all residues and foreign materials on the matching surface of crankcase.

Pay attention to not let these residues and foreign materials fall into crankcase.

**⚠ Caution**

To soap the residues into solvent so that the residues can be removed more easily.

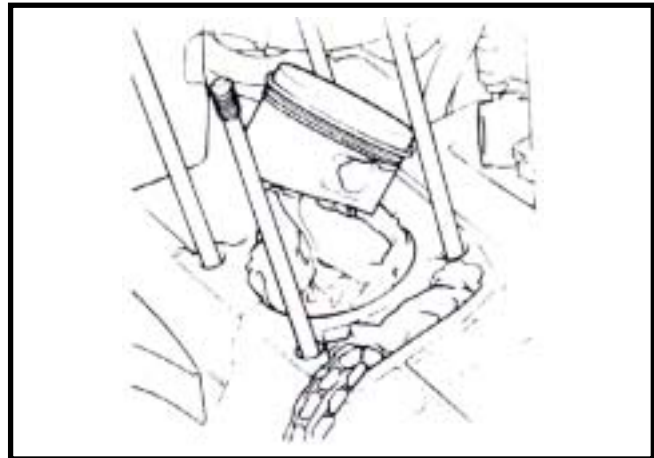

Install 2 lock pins and new gasket.

Coat engine oil to inside of cylinder, piston and piston rings.

Care to be taken when installing piston into cylinder. Press piston rings in one by one as installation.

**⚠ Caution**

Do not push piston into cylinder forcefully because this will cause the piston and the piston rings to be damaged.

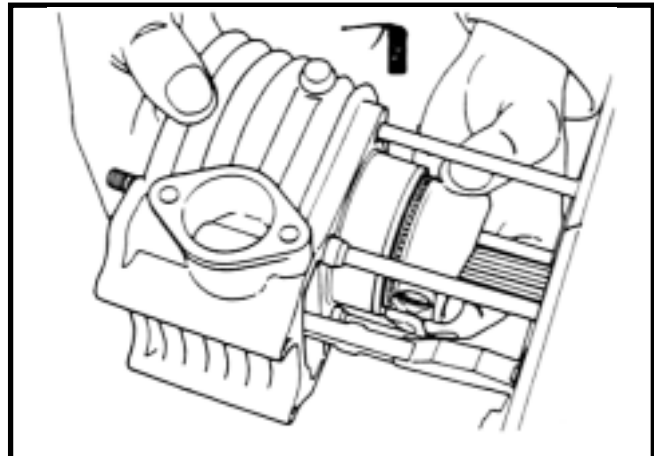

Install the cam chain plate, the cylinder gasket and lock pins.

Install cylinder head. (refer to Chapter 6)

Install the cam chain auto-adjuster. (2 bolts)

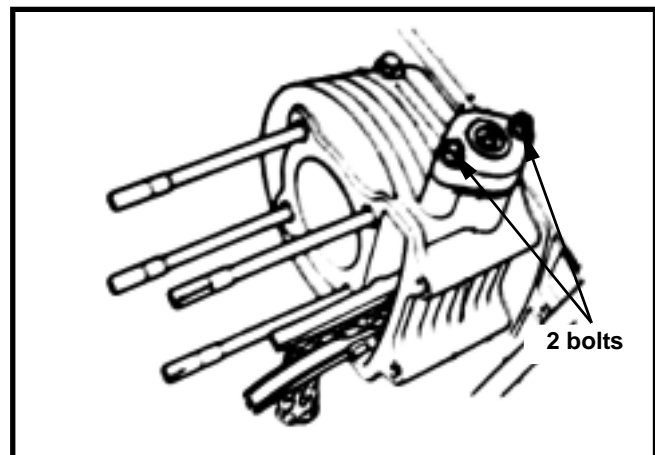

MAINTENANCE DESCRIPTION .....8-1	DRIVING BELT.....8-3
TROUBLE DIAGNOSIS.....8-1	SLIDING PULLEY .....8-5
LEFT CRANKCASE COVER .....8-2	CLUTCH/DRIVEN PULLEY..... 8-8
KICK STARTER ARM.....8-2	

**MAINTENANCE DESCRIPTION**

**PRECAUTIONS IN OPERATION**

**GENERAL INFORMATION**

Driving pulley, clutch, and driven pulley can be serviced on the motorcycle.  
 Driving belt and driving pulley surface must be free of grease.

**Specification**

Unit: mm

Item	Standard value	Limit
Driving belt width	<b>17.50</b>	-
ID of sliding pulley bushing	<b>20.035~20.085</b>	-
OD of sliding pulley hub	<b>20.01~20.025</b>	-
OD of roller	<b>15.920~16.080</b>	-
ID of clutch outer	<b>107.00~107.20</b>	-
Thickness of clutch lining	<b>4.000</b>	-
Free length of driving pulley spring	<b>97.20</b>	-
OD of driving pulley	<b>33.965~33.985</b>	<b>33.940</b>
ID of sliding pulley	<b>34.000~34.025</b>	<b>34.060</b>

ID: Inner Diameter  
 OD: Outer diameter

**Torque value**

Sliding pulley nut: 5.0~6.0kgf-m  
 Clutch outer nut: 5.0~6.0kgf-m  
 driving pulley nut: 5.0~6.0kgf-m

**Special Service Tools**

Clutch spring compressor  
 Bearing puller (inner type)  
 Clutch mounting nut wrench  
 Universal fixture

**TROUBLE DIAGNOSIS**

**Engine can be started but motorcycle can not be moved**

1. Worn driving Belt
2. Worn tilt plate
3. Worn or damaged clutch lining
4. Broken driven pulley

**Shudder or misfire when driving**

1. Broken clutch lining
2. Worn clutch lining

**Insufficient horsepower or poor high speed performance**

1. Worn driving belt
2. Insufficient spring capacity of driven pulley
3. Worn roller
4. Driven pulley operation un-smoothly

**LEFT CRANKCASE COVER**

**Left crankcase cover removal**

Remove air cleaner. (2 bolts)  
 Remove kick starter arm. (1 bolt)  
 Loosen vent strap on the front-left side of cover, and then remove the vent.  
 Remove engine left-side cover (8 bolts).

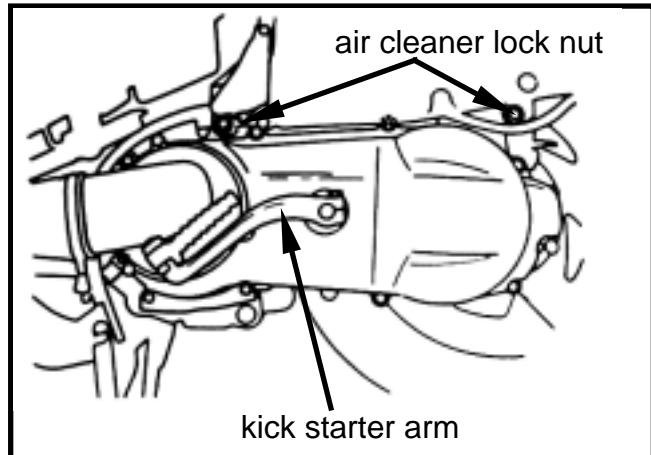

**KICK STARTER ARM**

**Disassembly**

Remove the return spring, starter shaft.  
 Remove driving gear, friction spring and washer.

**Inspection**

Check if starter shaft, driving gear, for wear or damage. Replace it with new one if necessary.  
 Check the return spring for spring force or damaged. Replace it with one if poor parts found.

**Reassembly**

Apply with some specified grease on the gear, shaft.  
 Install the friction spring of driving gear onto convex part of the case cover.  
 Install, return spring and starter shaft as diagram shown.  
 Install kick starter arm temporary.  
 Rotate the lever and then align driving gear with width-tooth on the starter shaft.  
 Install thrust washer and socket onto starter shaft.

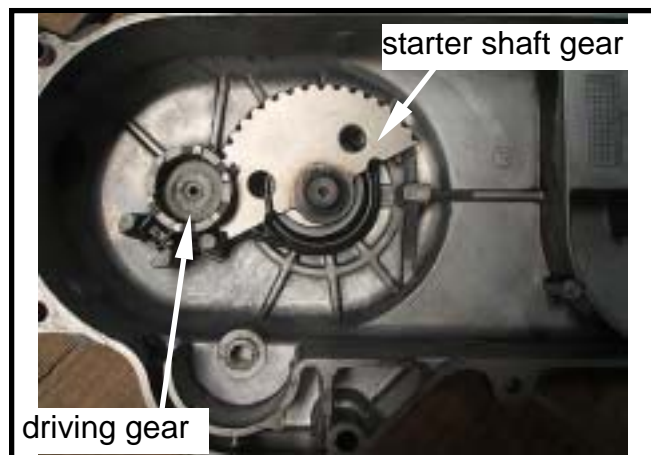
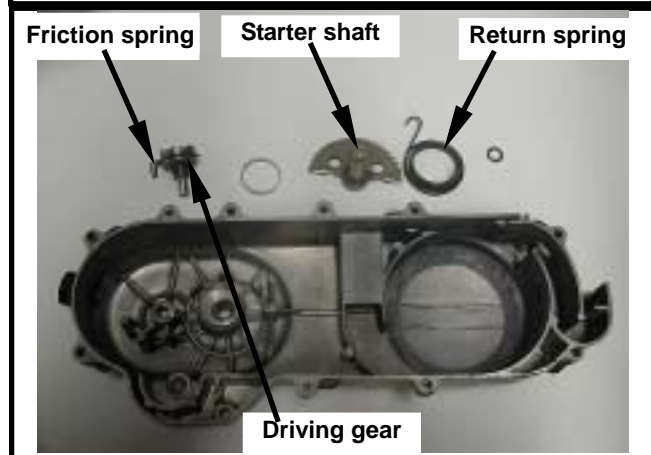

**Installation of the left crankcase cover**

Install the left crankcase cover. (8 bolts)  
 Install front vent tube of left cover and tighten the strap.  
 Install kick starter arm. (1 bolt)  
 Tighten the air cleaner. (2 bolts)

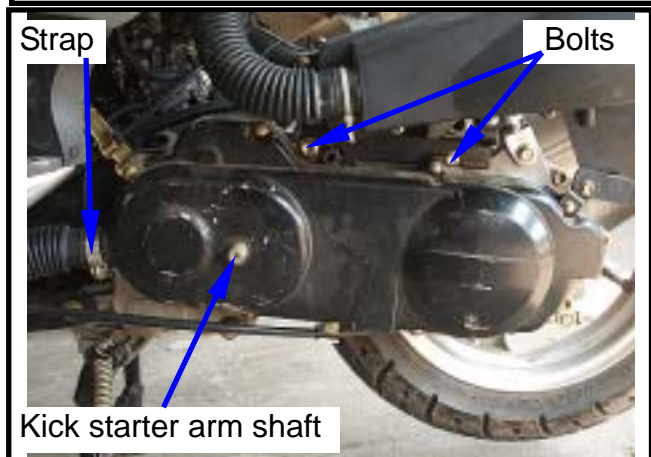

**DRIVING BELT**

**Removal**

Remove left crankcase cover.  
Hold the sliding pulley with a universal fixture, and then remove the nut and sliding pulley.

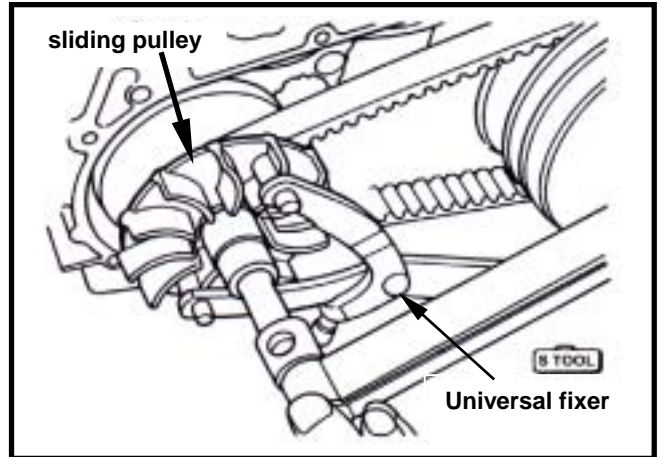

Hold driving pulley with universal fixture, and remove nut and clutch outer.

**⚠ Caution**

Using special service tools for tightening or loosening the nut. Fixed rear wheel or rear brake only will damage reduction gear system.

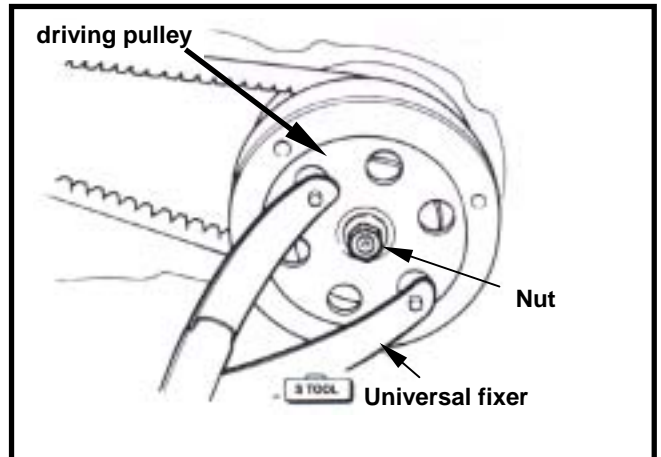

Push the driving belt into belt groove as diagram shown so that the belt can be loosened, and then remove.  
Driving belt and clutch at same time.

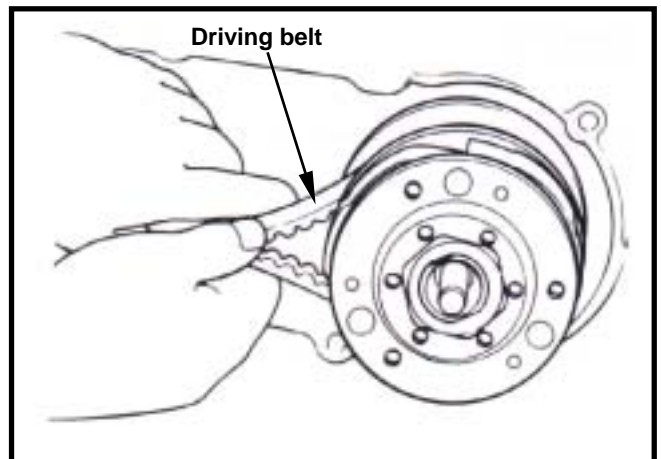

**Inspection**

Check the driving belt for crack or wear. Replace it if necessary.  
Measure the width of driving belt as diagram shown. Replace the driving belt if it exceed maintenance limited specification.

**Service Limit: 17.50mm**

**⚠ Caution**

- Using the genuine parts for replacement.
- The surfaces of driving belt or pulley must be free of grease.
- Clean up all grease or dirt before installation.

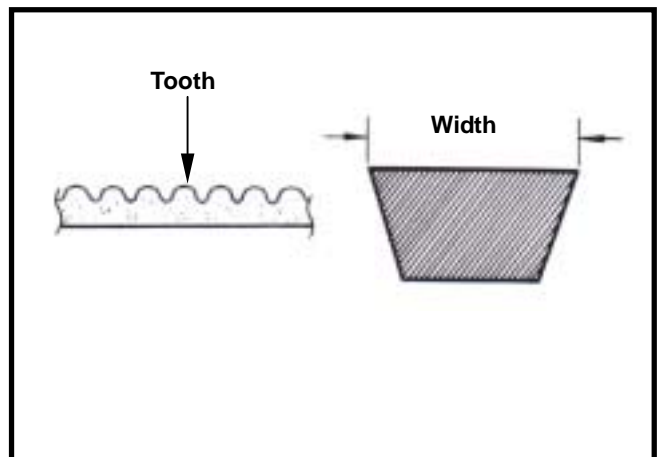

### Installation

Pull out the driving pulley and then insert the driving pulley.

### Caution

Pull out driving pulley and then insert the driving belt into the driving pulley so that the driving belt set can be installed onto sliding pulley more easily.

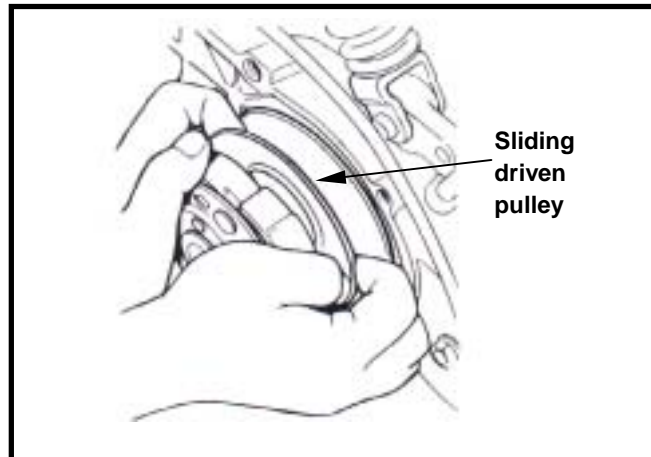

Install the starter gear.  
 Install the clutch set with driving belt onto the driving shaft.  
 Install the sliding pulley on the other end of belt.  
 Install clutch outer.

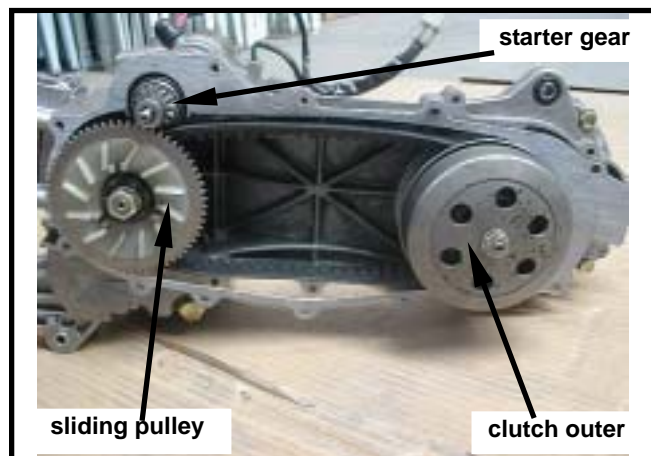

Install the clutch with universal fixture, and then tighten nut to specified torque value.  
**Torque value: 5.0~6.0 kgf-m**

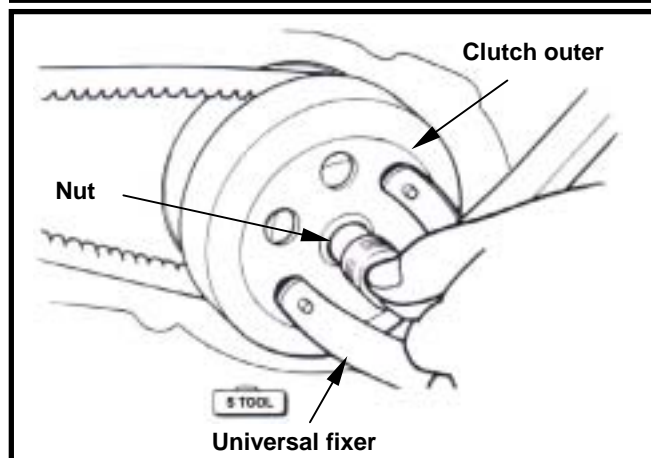

### Caution

When install the driving belt, if there is a arrow mark, then the arrow mark must point to rotation motion. If not, the letters on the belt must be forwarded to assembly direction.

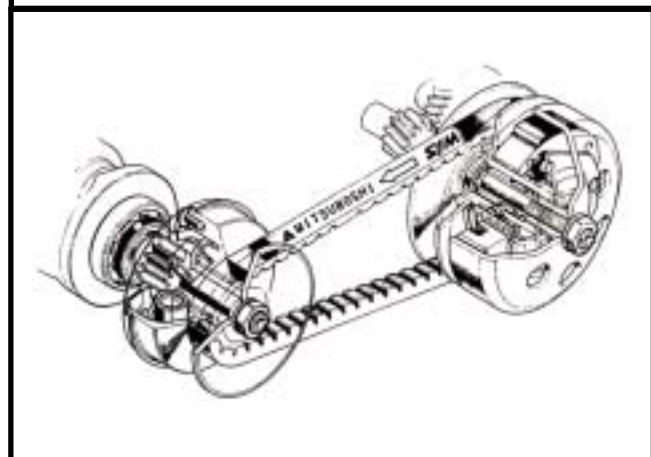



**SLIDING PULLEY**

**REMOVAL**

Remove left crankcase cover.  
Hold driving pulley with universal fixture, and then remove driving pulley nut.  
Remove driving pulley.

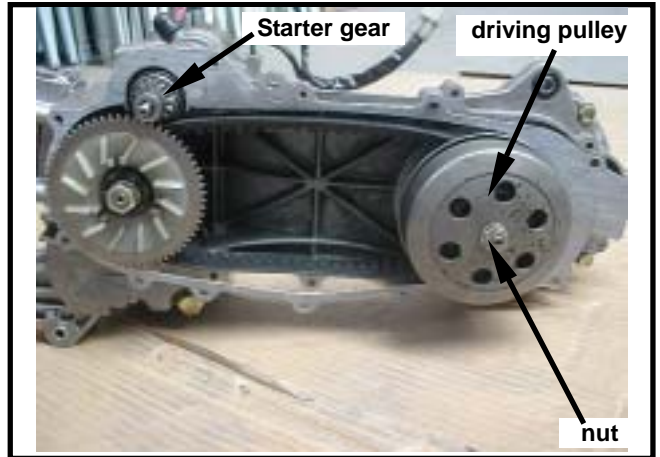

Remove the driving belt from the pulley.  
Remove sliding pulley set and driving pulley hub from crankshaft.  
Remove the belt and the starter gear.

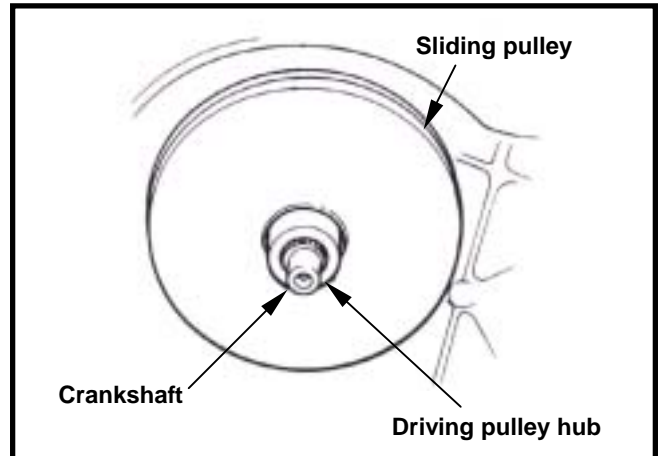

Remove tilt plate.

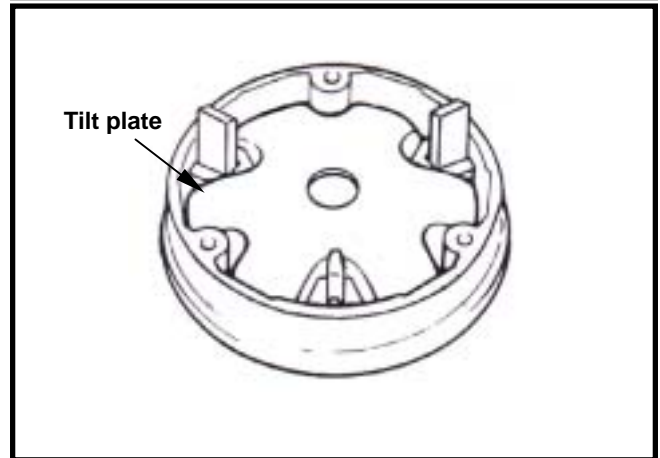

Remove weight rollers from sliding pulley.

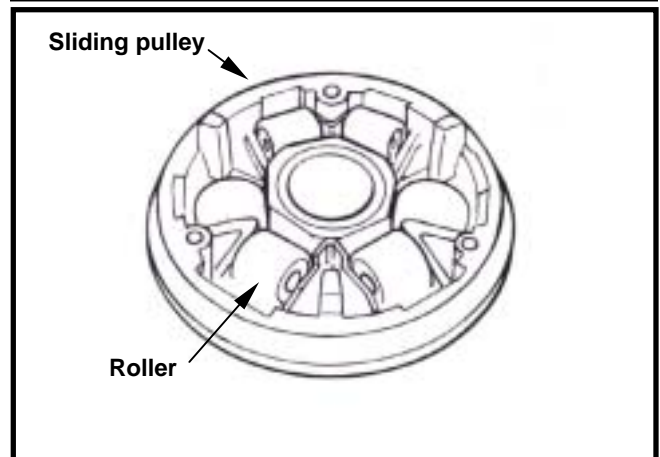

**Inspection**

The operation of sliding pulley is means of the weight roller to pressing on it with centrifuge force. And then the speed is changed by the title plate rotation. Thus, if weight rollers are wear out or damage, the centrifuge force will be effected.

Check if rollers are wear out or damage.

Replace it if necessary.

Measure each rollers' outer diameter.

Replace it if exceed the service limit.

**Service limit: 15.92 mm**

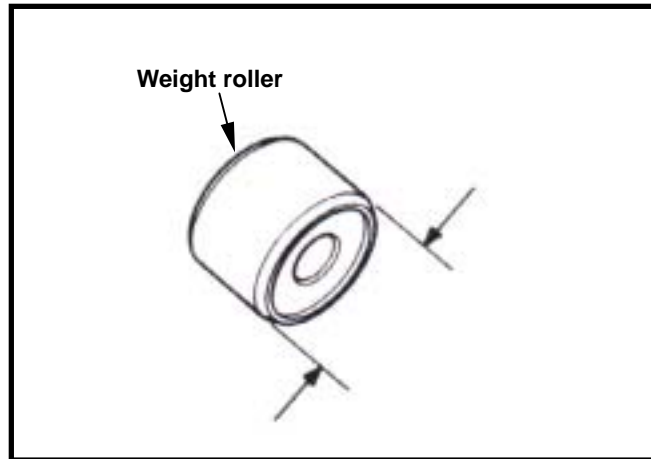

Check the pulley hub if damaged or wear out.

Replace it if necessary.

Measure the pulley hub's outer diameter.

Replace it if exceed the service limit.

**Service limit: 20.025 mm**

Measure the pulley hub's inner diameter.

Replace it if exceed the service limit.

**Service limit: 20.028 mm**

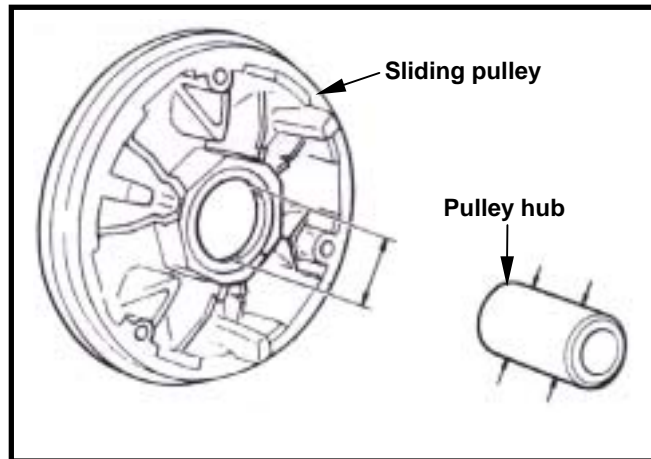

**Assembly/Installation**

Install the weight rollers.

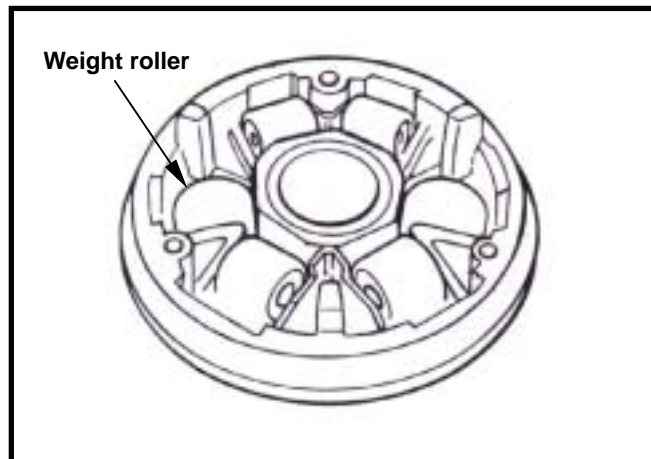

Install the title plate guide boot onto the title plate.

Install the title plate.

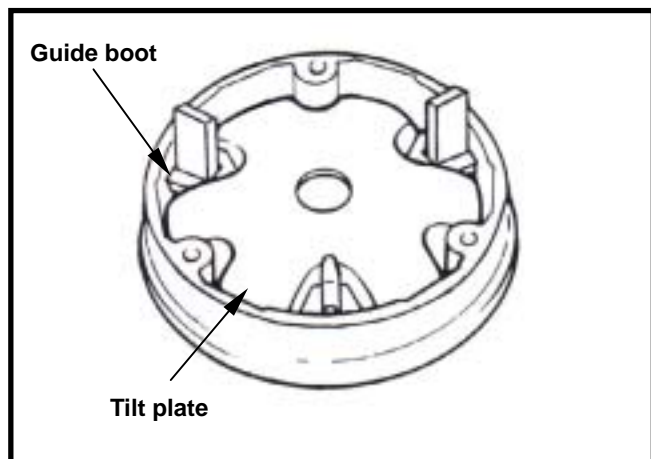

Apply with grease 4~5 g to inside of driving shaft hole, and install driving pulley hub.

**⚠ Caution**

The pulley surface has to be free of grease. Clean it with cleaning solvent.

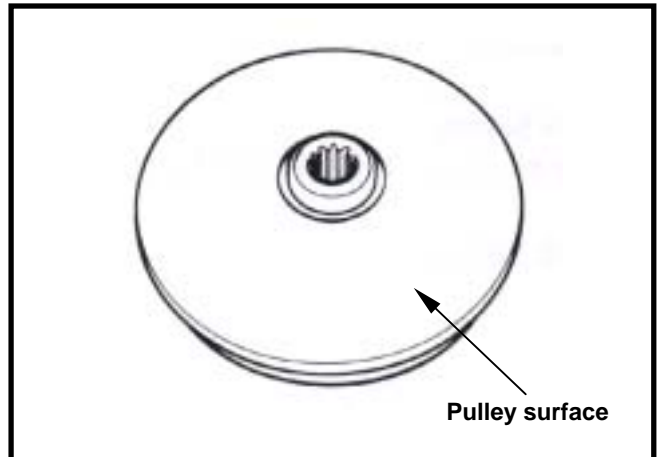

Install sliding pulley assembly onto crankshaft.

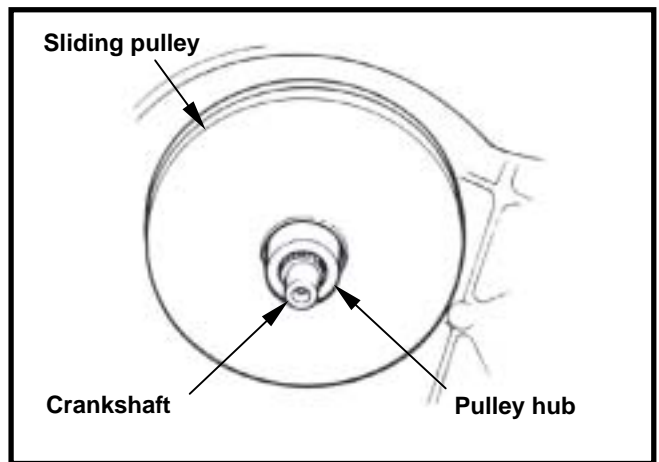

**DRIVING PULLEY INSTALLATION**

Press driving belt into pulley groove, and then press down the up & down sides of the driving belt to separate it away from the driving pulley hub.

**⚠ Caution**

To press down the up & down sides of the driving belt can avoid to pressing and damaging the belt when installing the driving pulley, and also can make sure that the driving pulley can be tighten.

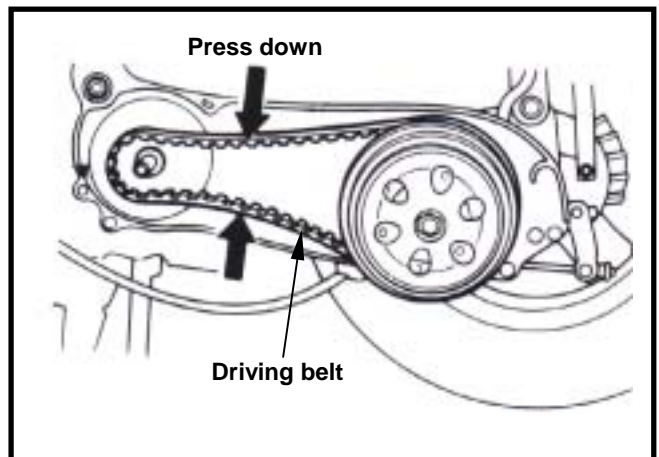

Install driving pulley, washer and nut.

**⚠ Caution**

Make sure that two sides of pulley surfaces have to be free of grease. Clean it with cleaning solvent.

Hold driving pulley with universal fixture. Tighten nut to specified torque.

**Torque value: 5.0~6.0 kgf-m**

Install left crankcase cover.



**CLUTCH/DRIVEN PULLEY  
DISASSEMBLY**

Remove driving belt and clutch/driven pulley. Install clutch spring compressor onto the pulley assembly, and operate the compressor to let nut be installed more easily.

**⚠ Caution**

Do not press the compressor too much.

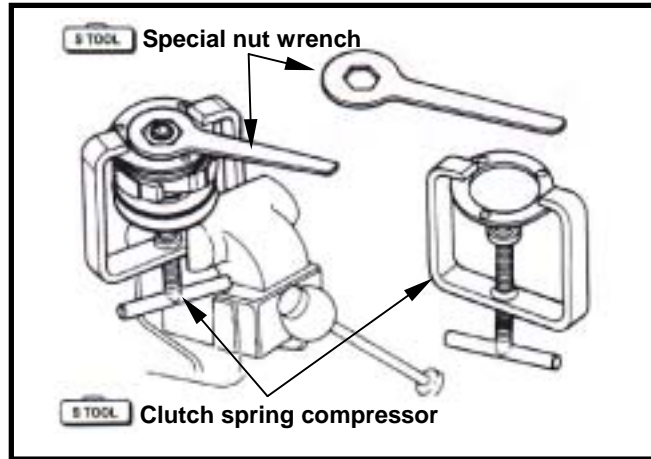

Hold the clutch spring compressor onto bench vise, and then remove mounting nut with special nut wrench. Release the clutch spring compressor and remove clutch and spring from driven pulley. Remove socket from driven pulley.

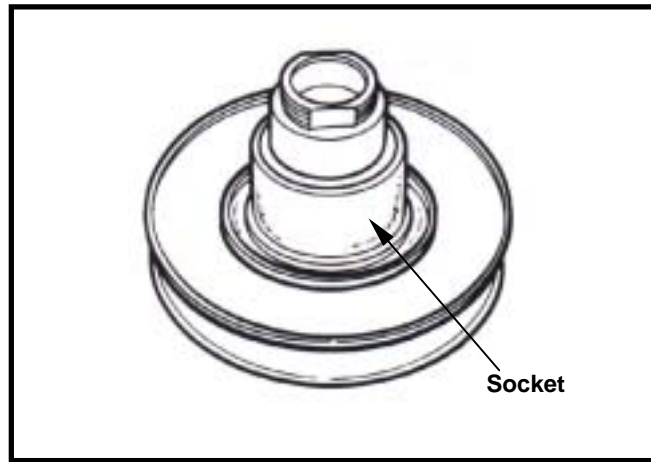

Remove oil seal from driven pulley. Remove guide pin, guide pin roller, and sliding pulley, and then remove O-ring & oil seal seat from sliding pulley.

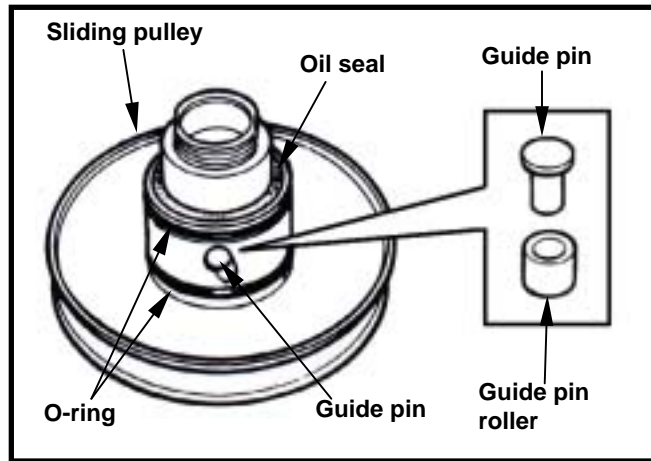

**INSPECTION**

**Clutch outer**

Measure the inner diameter of clutch outer friction face. Replace the clutch outer if exceed service limit.

**Service limit: 107.2 mm**

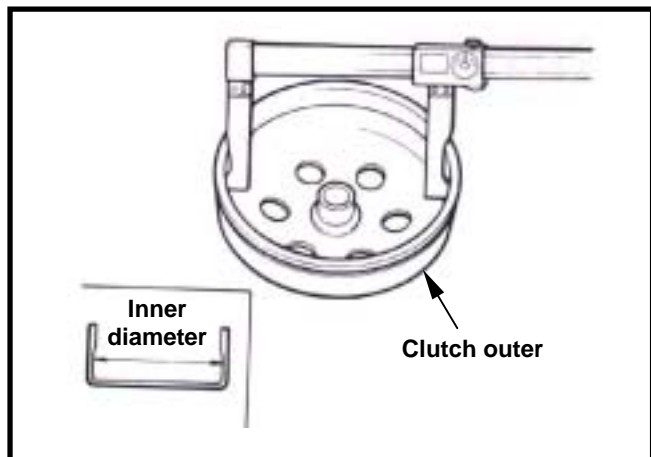

**Clutch lining**

Measure each clutch lining thickness.  
 Replace it if exceeds service limit.

**Service limit: 2.0mm**

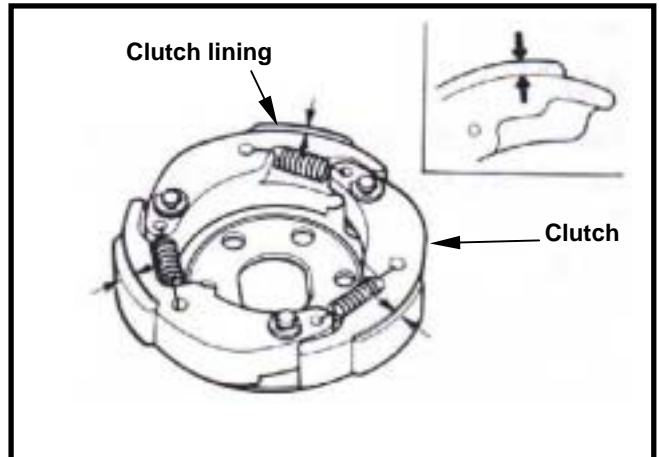

**Driven pulley spring**

Measure the length of driven pulley spring.  
 Replace it if exceeds service limit.

**Service limit: 93.2mm**

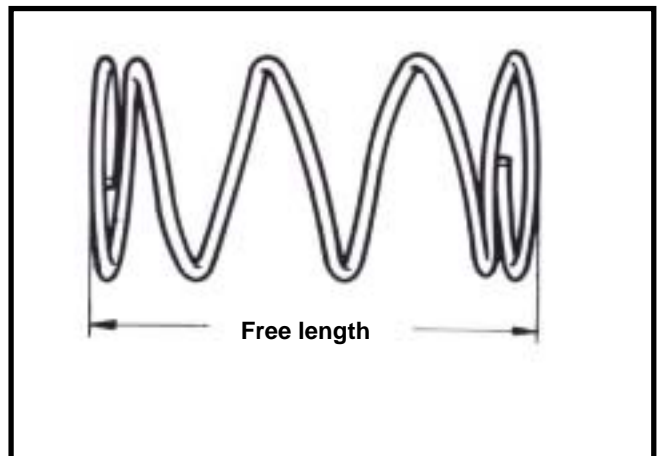

**Driven pulley**

Check following items;

If both surfaces are damage or wear.

If guide pin groove is damage or wear.

Replace damaged or worn components.

Measure the outer diameter of driven surface and the inner diameter of driven pulley.

Replace it if exceeds service limit.

**Service limit: Outer diameter 33.94mm**

**Inner diameter 34.06mm**

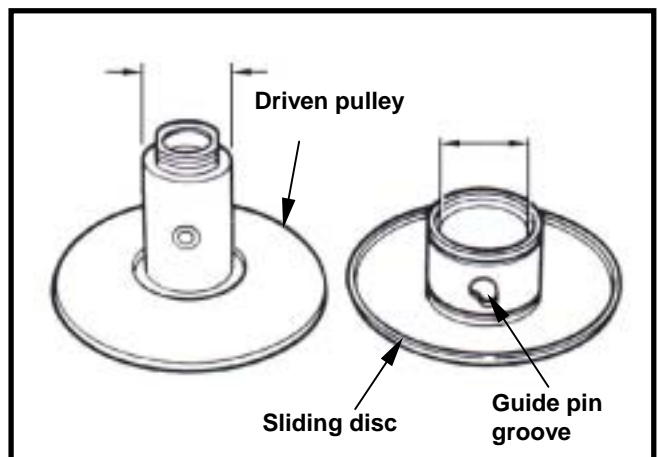

**Driven Pulley Bearing Inspection**

Check if the inner bearing oil seal is damage.  
 Replace it if necessary.

Check if needle bearing is damage or too big clearance. Replace it if necessary.

Rotate the inside of inner bearing with fingers to check if the bearing rotation is in smooth and silent.

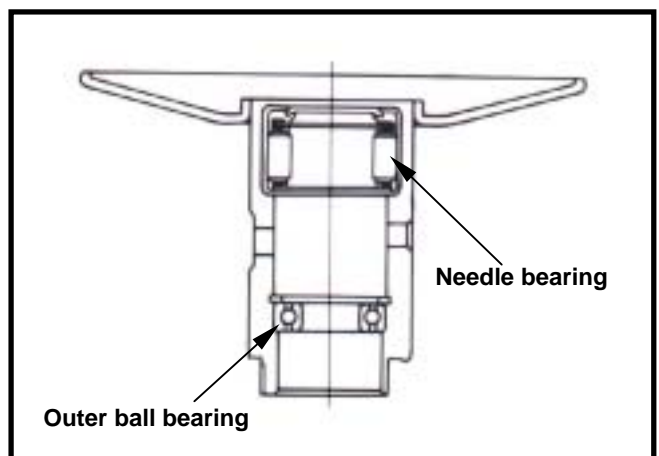

**Clutch Block Replacement**

Remove snap and washer, and then remove the clutch block and spring from the driving plate. Check if the spring is damaged or has insufficient elasticity.

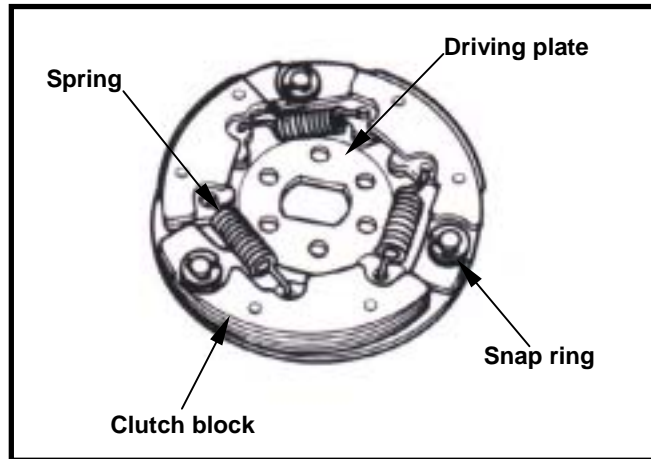

Check if the shock absorption rubber is damaged or deformed. Replace it if necessary. Apply grease to the setting pins.

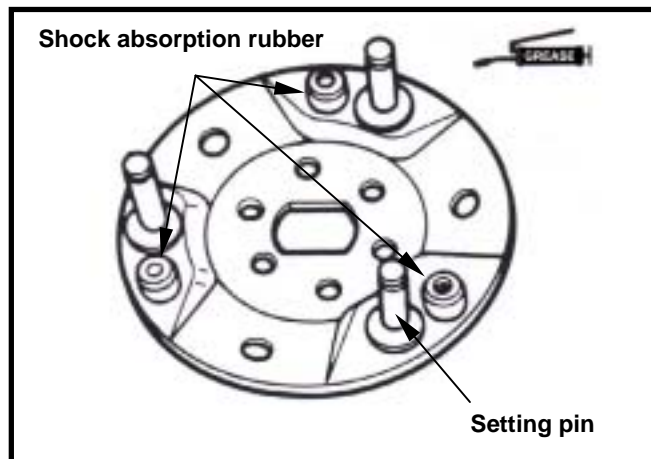

Apply grease to the setting pins. However, the clutch block should not be greased. If so, replace it. Install the new clutch block onto the setting pin and then push it to the specified location.

**⚠ Caution**

- Grease or lubricant will damage the clutch block and affect the block's connection capacity.

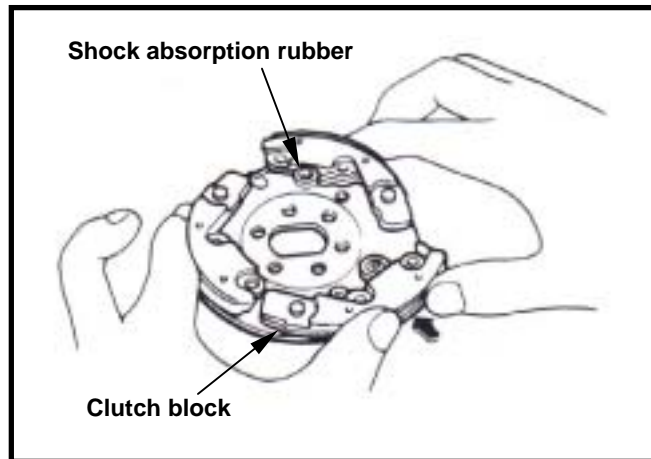

Install the spring snap into the groove with pliers.

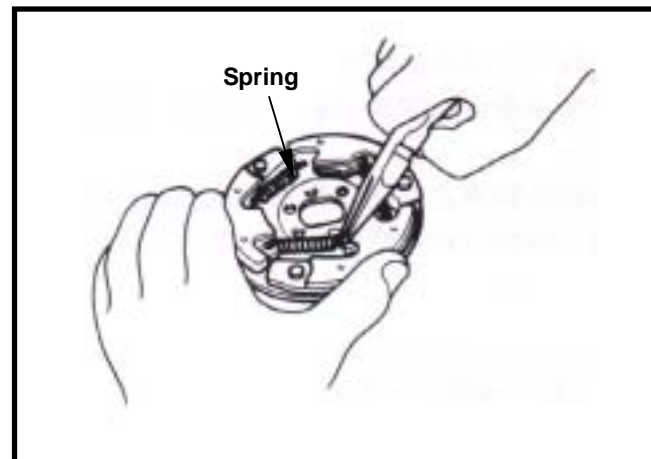

Install snap ring and mounting plate onto setting pin.

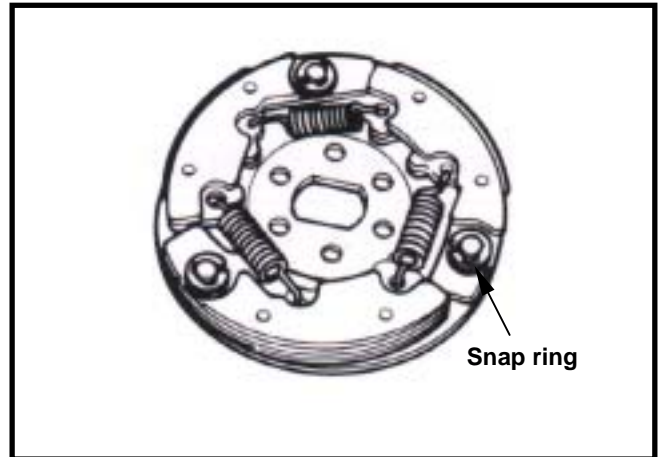

**REPLACEMENT OF DRIVEN PULLEY BEARING**

Remove inner bearing.

**⚠ Caution**

- If the inner bearing equipped with oil seal on one side in the driven pulley, then remove the oil seal firstly.
- If the pulley equipped with ball bearing, it has to remove snap ring and then the bearing.

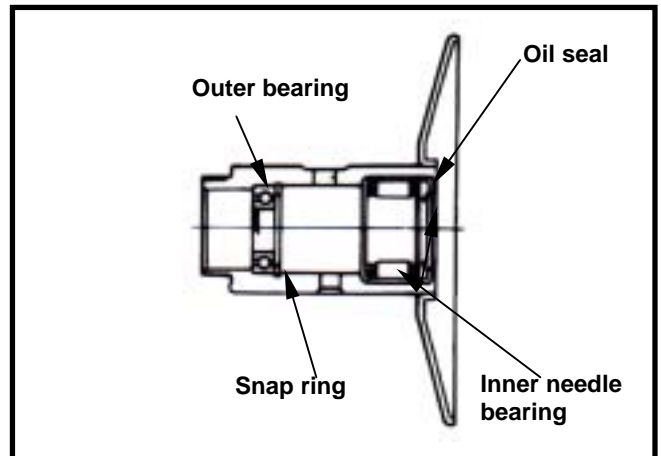

Remove snap ring and then push bearing forward to other side of inner bearing. Place new bearing onto proper position and its sealing end should be forwarded to outside.

Apply with specified grease. Recommended to use the KING MATE G-3. Install the snap ring and hold the bearing.

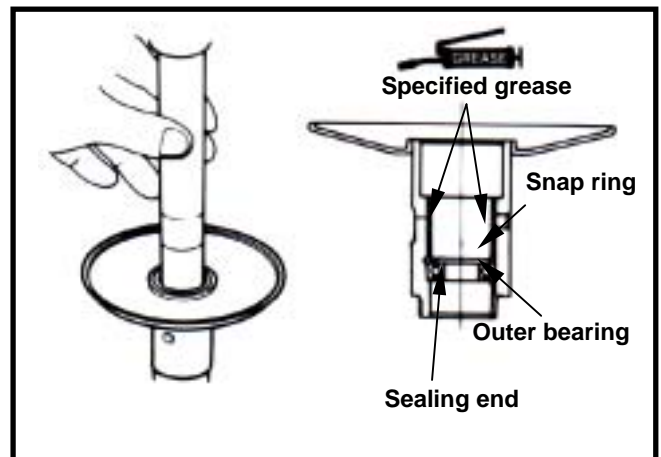

Install a new inner bearing.

**⚠ Caution**

- Its sealing end should be forwarded to outside as bearing installation.
- Install needle bearing with hydraulic presser. Install ball bearing by means of hydraulic presser.

Align oil seal lip with bearing, and then install the new oil seal (if necessary).

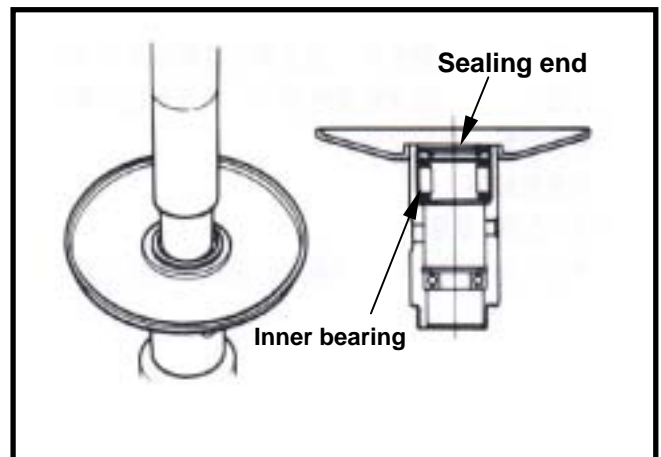

**INSTALLATION OF CLUTCH/DRIVEN PULLEY ASSEMBLY**

Install new oil seal and O-ring onto sliding pulley. Apply with specified grease to lubricate the inside of sliding pulley.

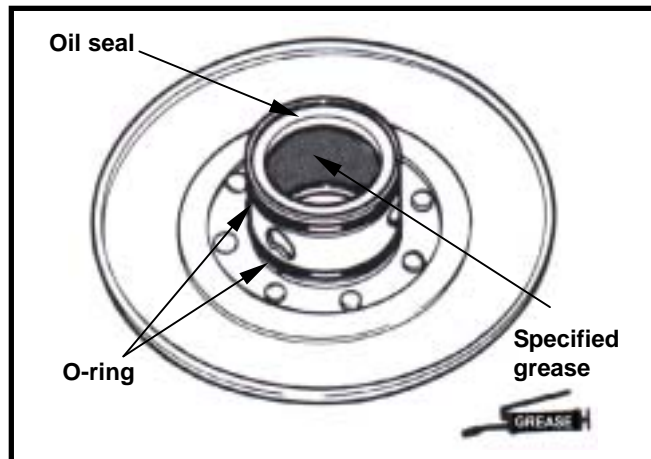

Install sliding pulley onto driven pulley. Install guide pin and guide pin roller.

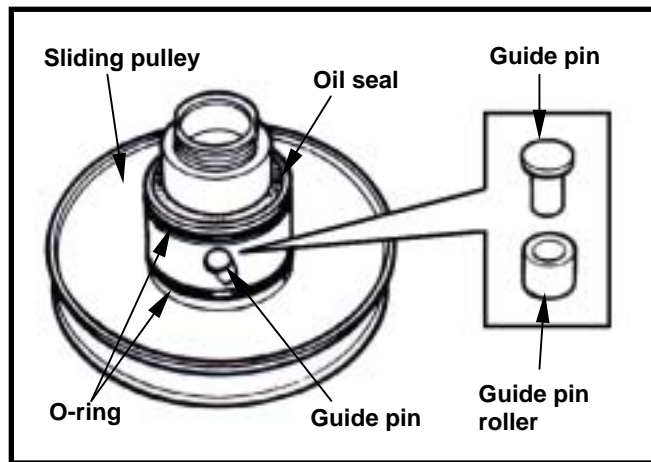

Install oil socket.

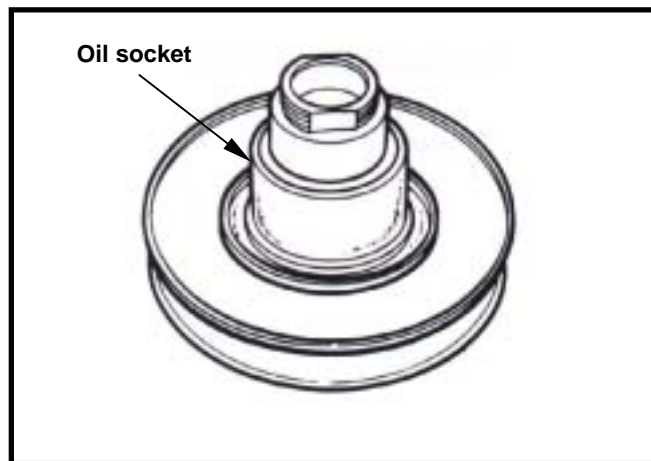

Install driving belt, spring and clutch into clutch spring compressor, and press down the assembly by turning manual lever until mounting nut that can be installed. Hold the compressor by bench vise and tighten the mounting nut to specified torque with special nut wrench. Remove the clutch spring compressor. **Torque value: 5.0~6.0 kg-m** Install clutch/driven pulley and driving belt onto driving shaft.

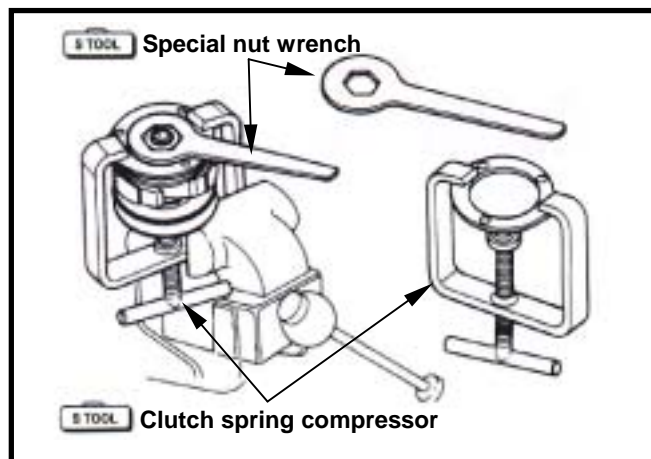



OPERATIONAL PRECAUTIONS .....9-1	INSPECTION OF FINAL DRIVING MECHANISM..9-2
TROUBLE DIAGNOSIS.....9-1	BEARING REPLACEMENT.....9-3
DISASSEMBLY OF FINAL DRIVING MECHANISM .....9-2	RE-ASSEMBLY OF FINAL DRIVING MECHANISM.....9-5

**OPERATIONAL PRECAUTIONS**

**Specification**

Application gear oil: 4-stroke lubricant  
 Recommended oil: KING MATE serial gear oils  
 Oil quantity: 120 c.c. (110 c.c. when replacing)

**Torque value**

Gear box cover 2.0~2.4 kgf-m  
 Gear oil drain plug 1.0~1.4 kgf-m  
 Gear oil filling bolt 0.8~1.2 kgf-m

**Tools**

**Special service tools**

Inner type bearing puller  
 Outer type bearing puller  
 Gear box oil seal installer  
 Gear box bearing installer

**TROUBLE DIAGNOSIS**

**Engine can be started but motorcycle can not be moved**

Damaged driving gear  
 Burnt out driving gear  
 Broken driving belt

**Gear oil leaks**

Excessive gear oil  
 Worn or damage oil seal

**Noise**

Worn or burnt gear  
 Worn gear

## DISASSEMBLY OF FINAL DRIVING MECHANISM

Remove the rear wheel. (refer to chapter 15)  
Remove the clutch.  
Drain gear oil out from gear box.  
Remove gear box cover bolts (7bolts) and then remove the gear box cover and the final driving shaft.  
Remove gasket and setting pin.

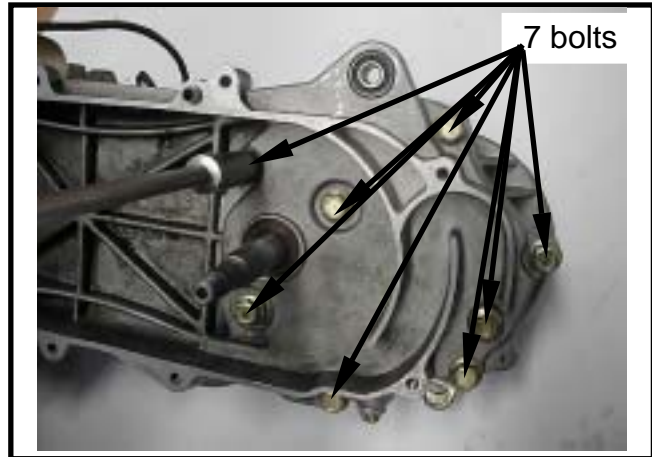

Remove countershaft and gear.  
Remove final driving gear and shaft.

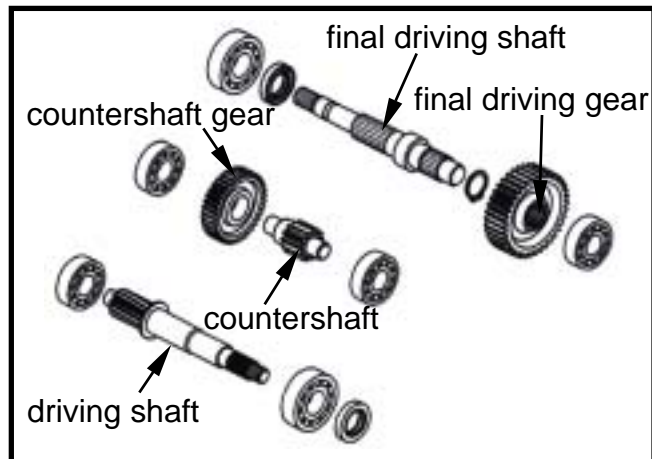

## INSPECTION OF FINAL DRIVING MECHANISM

Check if the countershaft and the gear are wear or damage.

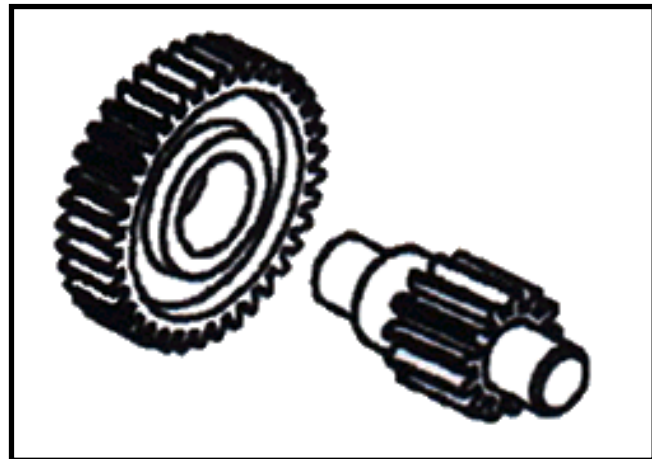

Check if the final driving shaft and gear are burn, wear or damage.

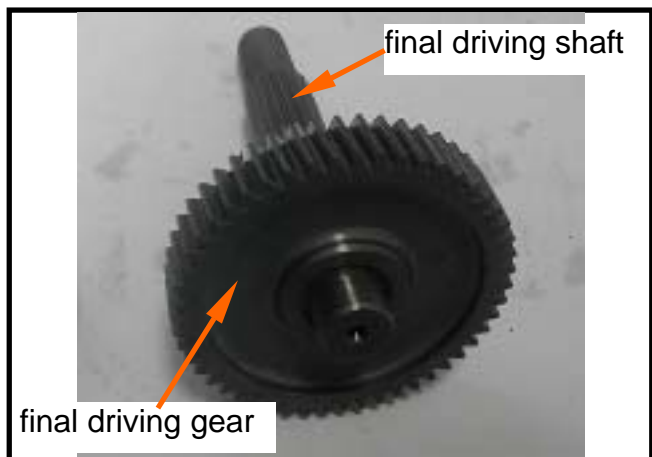

Check bearings on the gear box cover. Rotate each bearing's inner ring with fingers. Check if bearings can be turned in smooth and silent, and also check if bearing outer ring is mounted on gear box & cover tightly. If bearing rotation is uneven, noising, or loose bearing mounted, then replace it. Check oil seal for wear or damage, and replace it if necessary.



Check driving shaft and gear for wear or damage.

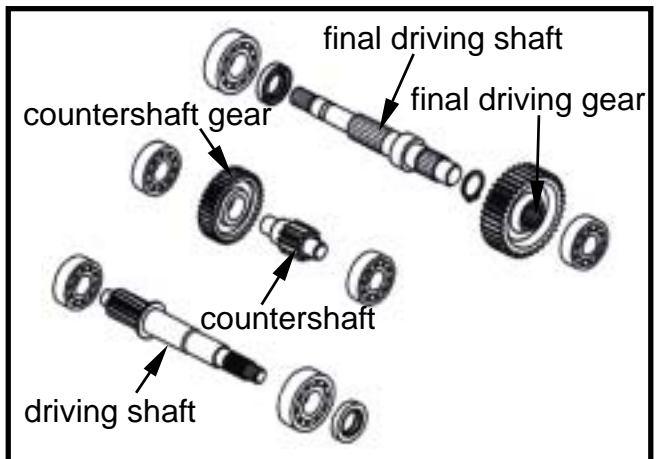

**BEARING REPLACEMENT**

**⚠ Caution**

Never install used bearings. Once bearing removed, it has to be replaced with new one.

Remove driving shaft bearing from left crankcase using following tools;  
Inner type bearing puller

Install new driving shaft bearing into left crankcase.

**Tool:**

Press the bearing into cover with C type hydraulic presser or bearing installer.

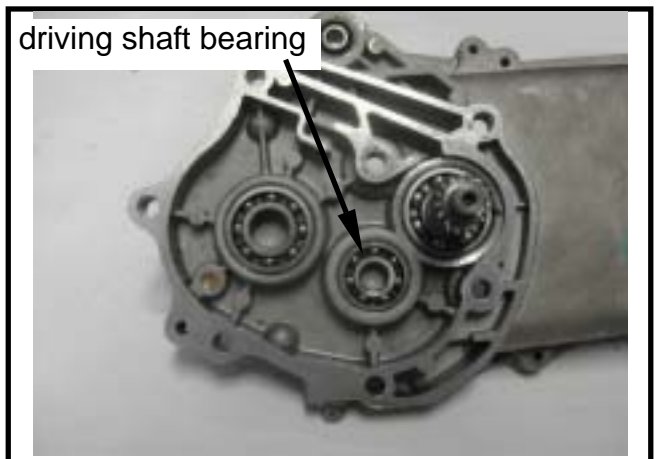

## 9. FINAL DRIVING MECHANISM

SYM

Press out the driving shaft from the crankcase.  
Remove oil seal from the crankcase.  
Remove the driving shaft bearing from the gear box cover with the inner type bearing puller.

### **Caution**

Using the bearing protector as pressing out the driving shaft from the gear box cover.

### **Specified tool:**

Inner type bearing puller.

If the driving shaft is pulled out with its bearing, then remove the bearing with bearing puller and bearing protector.

### **Tool:**

Multi-functional bearing puller

Bearing protector

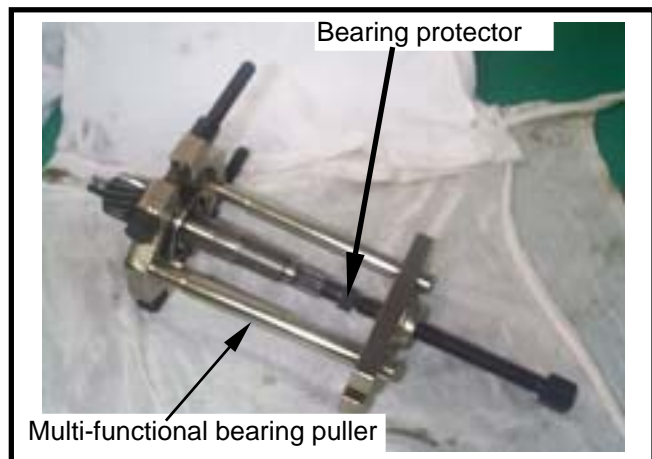
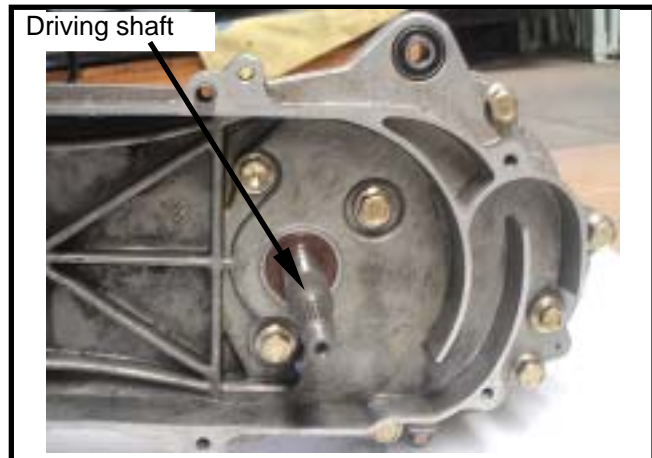

Install a new driving shaft bearing onto crankcase.

Then, install the driving shaft.

### **Specified tool:**

Press the bearing in with C type hydraulic presser or bearing installer.



Install a new final driving shaft bearing onto crankcase.

### **Specified tool:**

Press the bearing in with C type hydraulic presser or the bearing installer.

Apply with some grease onto the lip section of oil seal and then install the seal.

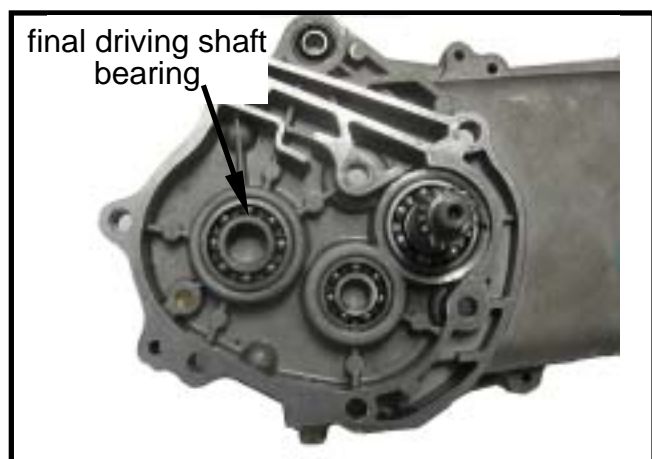

**RE-ASSEMBLY OF FINAL DRIVING MECHANISM**

Install final driving shaft and final driving gear, countershaft, and countershaft gear.

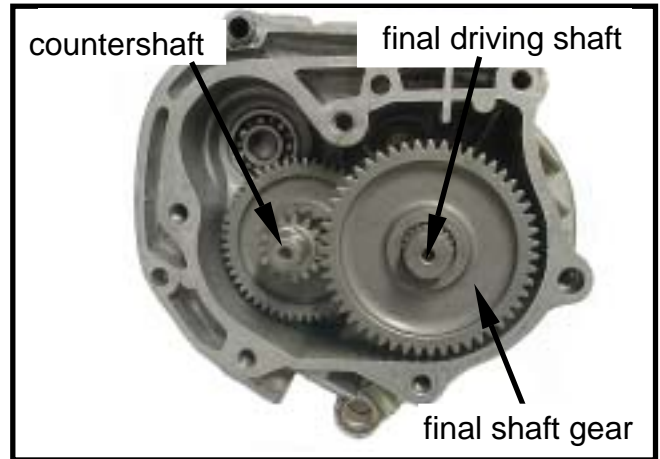

Install the setting pins(2 pins) and new gasket.

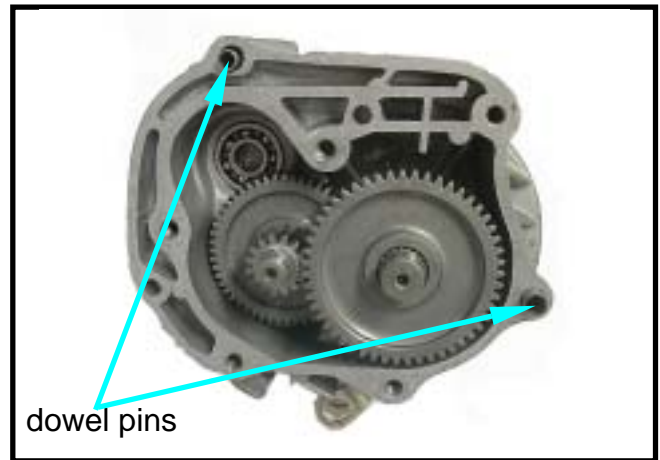

Apply with grease onto the oil seal lip of final driving shaft.

Install the gear box cover and 7 bolts.  
(tighten the bolts)

**Torque: 2.0~2.4 kgf-m**

Install the clutch/sliding driving pulley.  
Install the driving pulley, belt and left  
crankshaft cover.

Install the rear wheel.

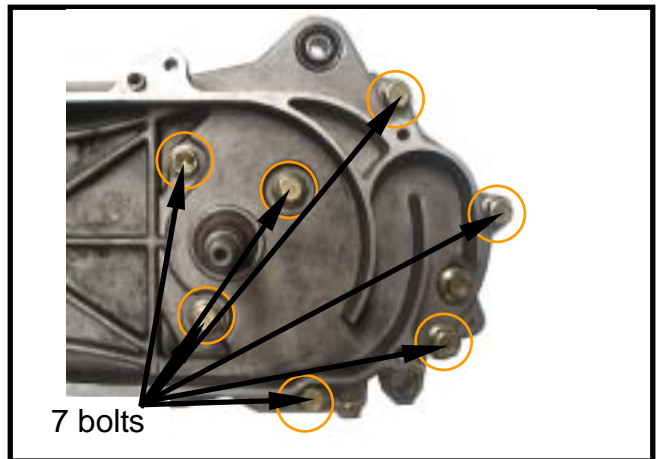

Add gear oil.

**Recommended usage: SYM HYPOID  
GEAR OIL (SAE 85W-140)**

(110 cc: standard capacity)

(100 cc: when replacement)



PRECAUTIONS IN OPERATION ..... 10-1	RIGHT CRANKCASE COVER INSTALLATION ... 10-4
A.C.GENERATOR REMOVAL..... 10-2	MOUNTED COIL SET INSTALLATION..... 10-4
RIGHT CRANKCASE COVER REMOVAL . 10-3	FLY WHEEL INSTALLATION..... 10-4

**PRECAUTIONS IN OPERATION**

**General information**

- Refer to chapter 5: Engine removal and installation
- Refer to chapter 1: The troubleshooting and inspection of A.C. generator

**Specification**

Unit: mm

Item	Service Limit
ID of starting driven gear	32.060
OD of starting clutch cover	27.940

**Torque value:**

Flywheel nut	3.5~4.5kgf-m
Exhaust muffler bolt 6 mm	0.7~1.1kgf-m
Oil screen cover	1.3~1.7kgf-m

**Special service tools**

- Flywheel puller
- Universal fixture

A.C. GENERATOR REMOVAL

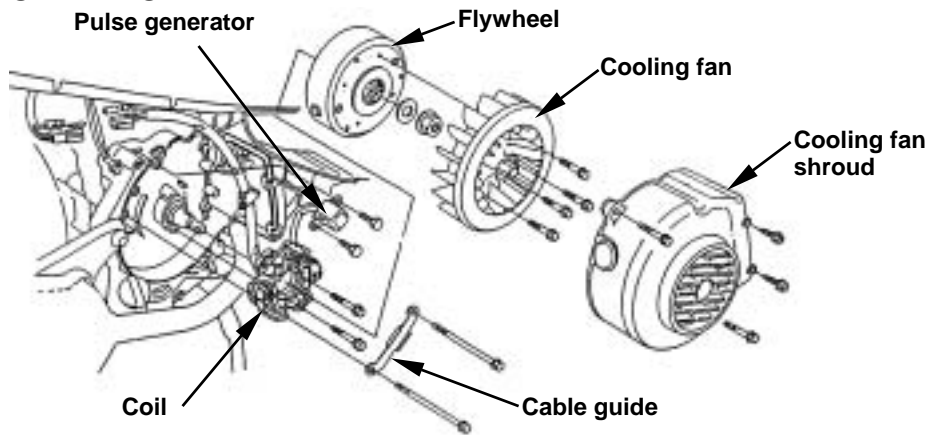

Drain out the engine oil.  
Remove the exhaust muffler. (2 bolts, 2 nuts)  
Remove the fan shroud. (4 bolts)



Remove the fan. (4 bolts)

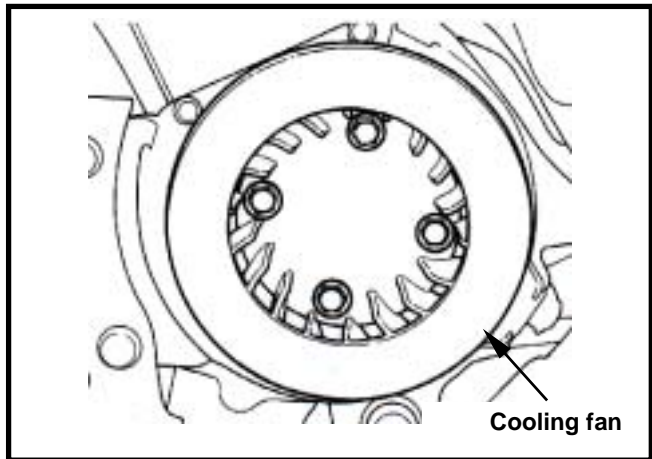

Hold the flywheel with the universal fixture.  
Remove the 10mm nut on the flywheel.

**Special Service Tools:**  
**Universal Fixture**

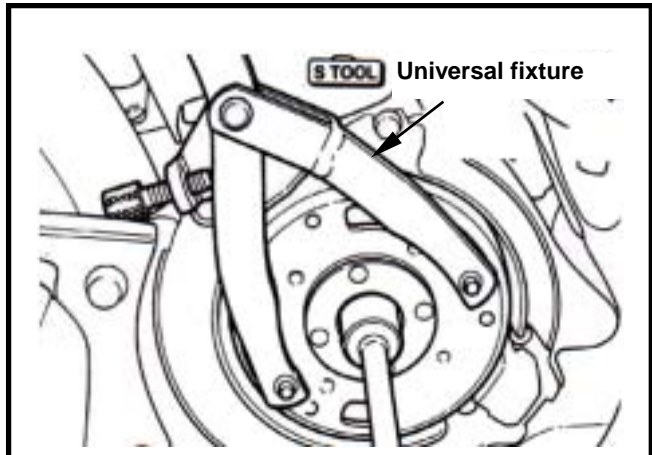

Remove the flywheel with the flywheel puller.

**Special service tools:**  
**Flywheel puller**  
**Shaft protector**

**⚠ Caution**

Install a shaft protector on the right end of crankshaft to avoid damaging the crankshaft before installing the flywheel puller.

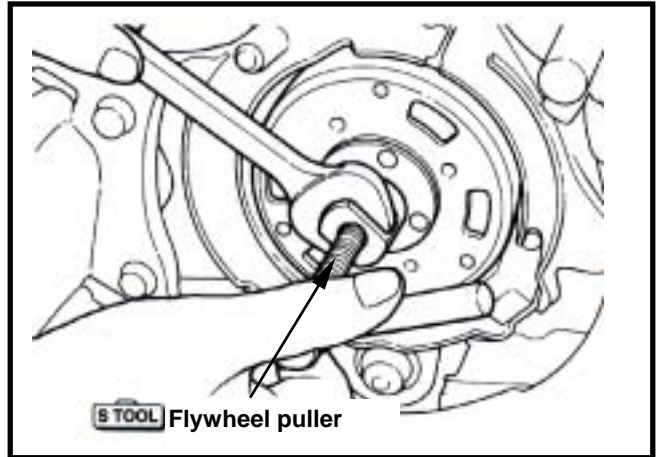

Remove the connectors of the A.C. generator and pulse generator.

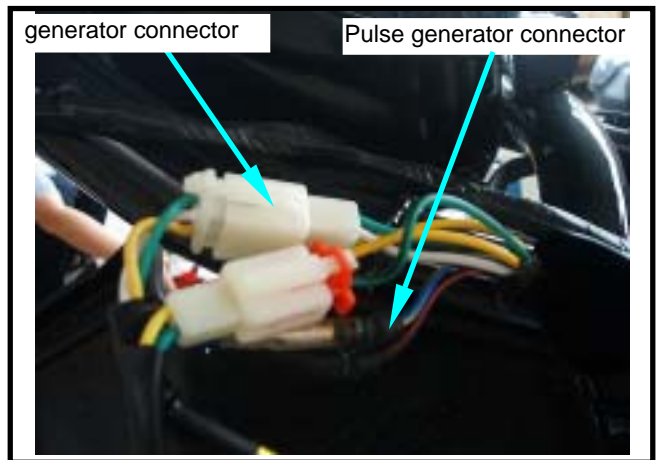

Remove the 6 bolts for the pulse generator, the A.C. generator coil and cable guide. Then, remove the A.C. generator assembly.

**⚠ Caution**

Do not damage the alternator coil.

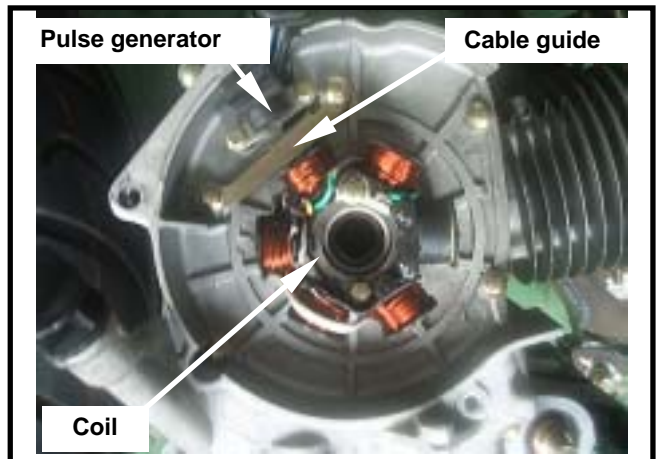

**RIGHT CRANKCASE COVER REMOVAL**

Remove the right crankcase cover. (8 bolts)  
 Remove setting pin and gasket.  
 Remove the gasket or foreign materials on the connection surfaces of both the cover and crankcase.

**⚠ Caution**

Do not damage the connection surfaces.

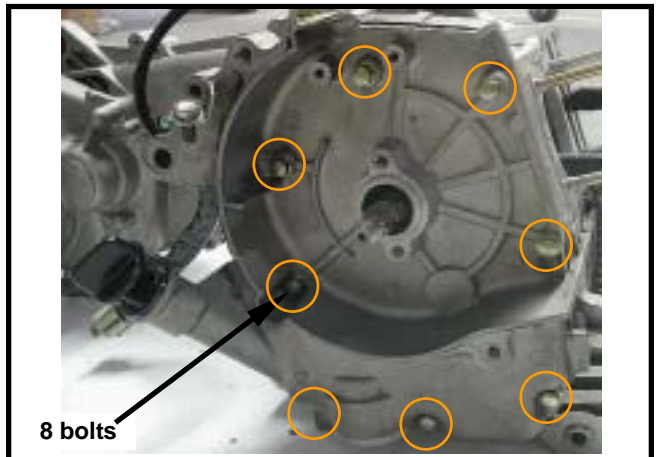



**RIGHT CRANKCASE COVER INSTALLATION**

Install setting pin and new gasket on the crankcase.  
 Replace the right crankshaft oil seal of the crankcase and apply some oil onto the oil seal lip.  
 Install right crankcase cover onto the right crankcase. (8 bolts)  
**Torque value: 1.5~2.0kgf-m**

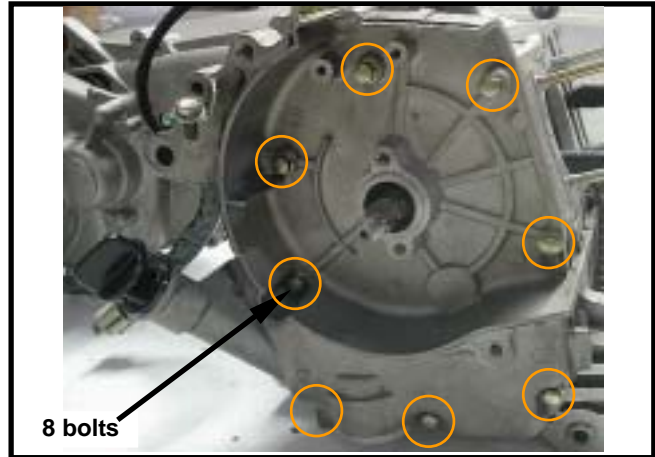

**MOUNTED COIL SET INSTALLATION**

Install the coil set onto right crankcase cover. (2 bolts)  
 Install pulse generator. (2 bolts)  
**Torque: 1.5~2.0kgf-m**  
 Tie the wire harness hose onto the indent of crankcase.

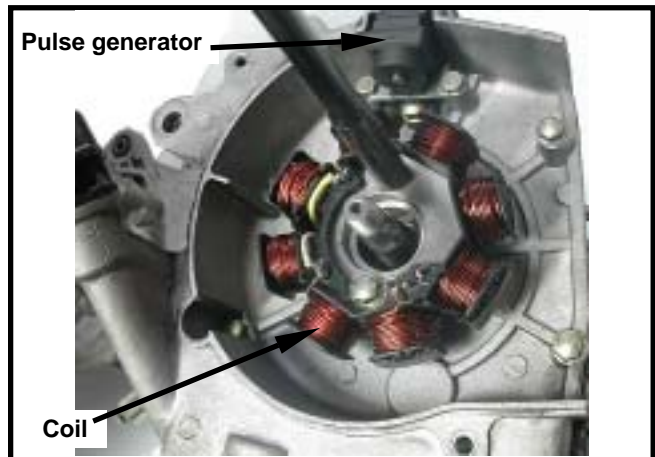

Install A.C. generator connector and pulse generator connector.

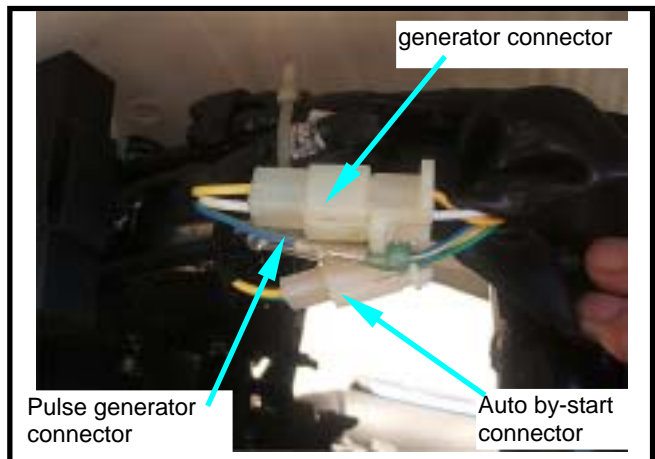

**FLYWHEEL INSTALLATION**

Make sure that there is no magnetic powder. If so, clean up it.  
 Align insert on crankshaft with the flywheel groove, and then install the flywheel.  
 Hold the flywheel with flywheel holder, and tighten its nut.  
**Torque value: 5.0~6.0kgf-m**  
**Special service tool: Universal fixture**

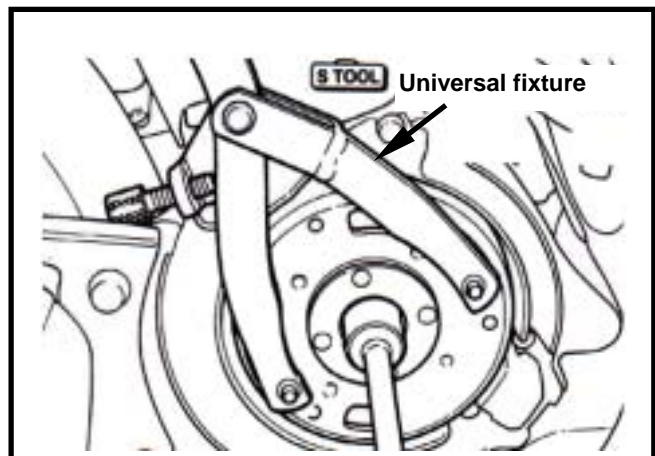

Install the cooling fan. (4 bolts)

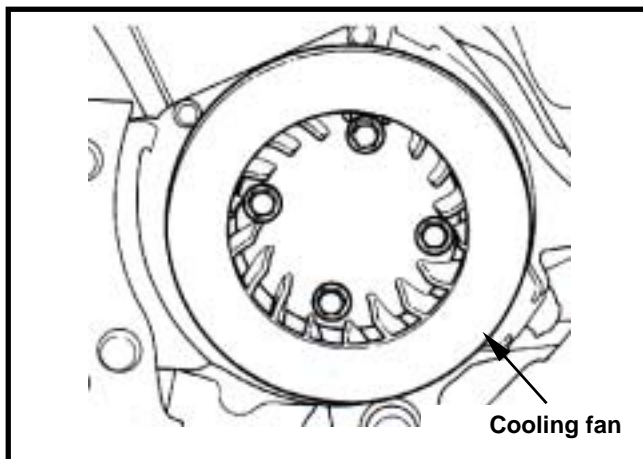

Install the cooling fan shroud. (4 bolts)  
Install the exhaust muffler. (2 bolts, 2 nuts)  
Add some engine oil according the specified quantity.

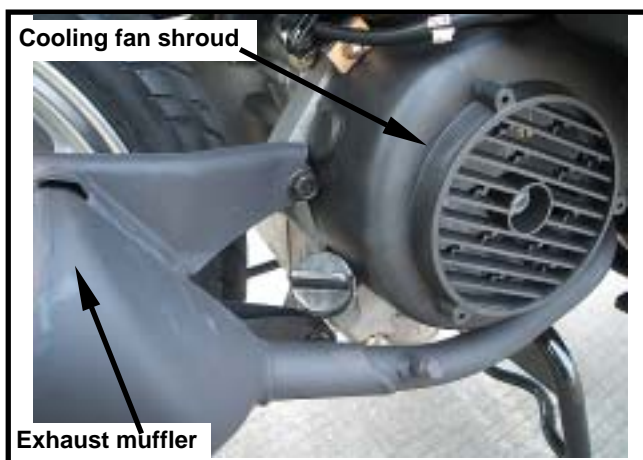

MECHANISM DIAGRAM ..... 11-1	DISASSEMBLY OF CRANKCASE 11-3
OPERATIONAL PRECAUTIONS... 11-2	CRANKSHAFT INSPECTION ..... 11-5
TROUBLE DIAGNOSIS..... 11-2	ASSEMBLY OF CRANKCASE ..... 11-6

**MECHANISM DIAGRAM**

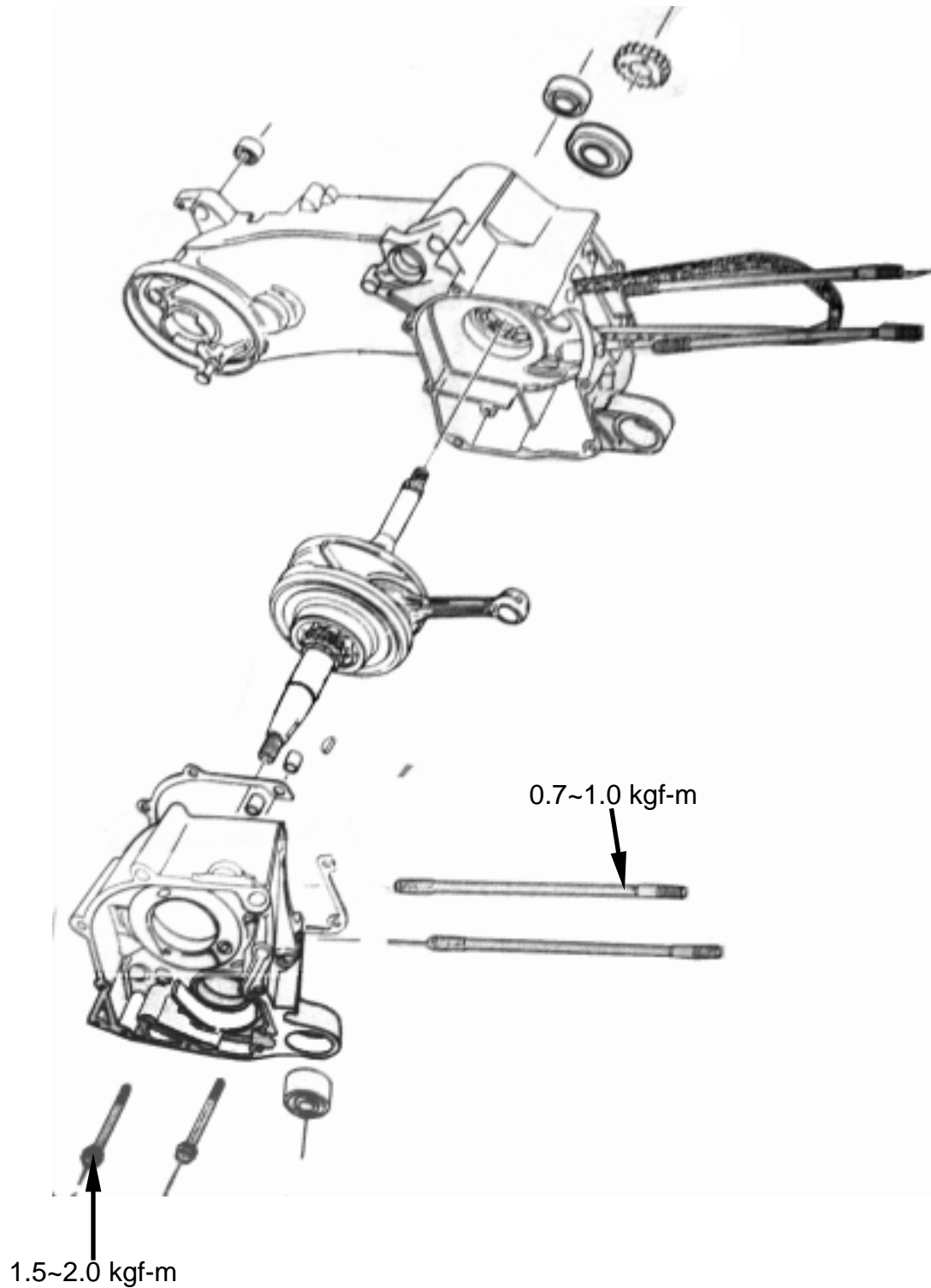

## OPERATIONAL PRECAUTIONS

### General Information

- This Section contains descriptions concerning disassembly of the crankcase so that the crankshaft can be serviced.
- Complete following operations before disassembling crankcase.

Engine	Chapter 5
Cylinder head	Chapter 6
Cylinder and piston	Chapter 7
V-belt Drive pulley	Chapter 8
AC generator/ Starting Clutch	Chapter 10

If the crankshaft bearing or timing sprocket need be replaced, then the crankshaft set have to replaced.

### Specification

Unit: mm

Item	Standard	Limit
Left, right clearance of the big end of the connecting rod	0.100~0.350	0.550
Radial clearance of the big end of the connecting rod	0.000~0.008	0.050
Run-out		Below 0.030

### Torque value

Bolts for crankcase	0.8~1.2 kgf-m
Bolts for cylinder/cylinder head	0.7~1.0 kgf-m
Engine oil draining plug	3.5~4.5 kgf-m
Bolts for cam chain tensioner	0.8~1.2 kgf-m

### Special Service Tools

- Crankcase remover/set
- Crankshaft installation puller
- Inner type bearing puller
- Outer type bearing puller
- Bearing pressing tools
- Oil seal pressing tools

## TROUBLE DIAGNOSIS

### Engine noise

- Loose crankshaft bearing
- Loose crankshaft pin bearing
- Wear piston pin or piston pin hole

**DISASSEMBLY OF CRANKCASE**

Remove the 1 bolt from the right crankcase.

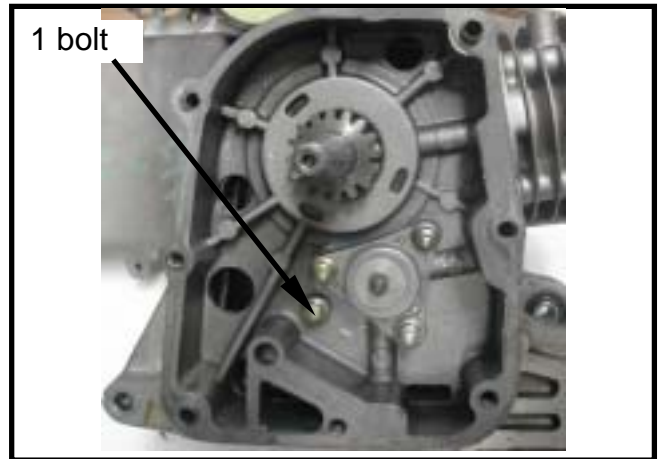

Remove the cam chain tensioner (hex socket bolt) from the left side of crankcase.

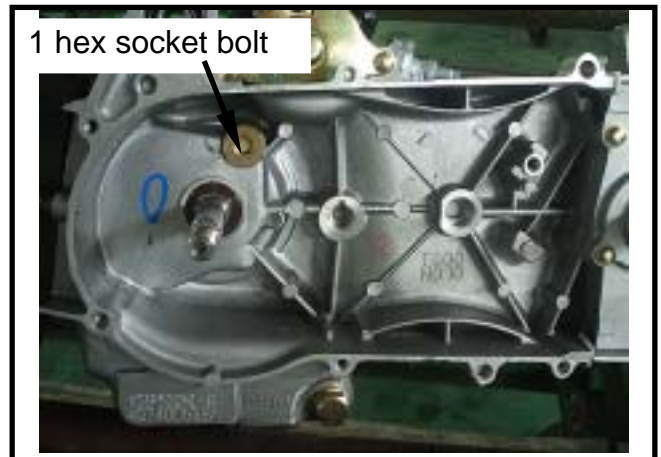

Place the left side of crankcase upward, and then install the crankcase remover/set onto the crankcase.

Drive the screw of the crankcase remover/set into the crankcase, and then separate the left and the right crankcases. Remove the cam chain.

**⚠ Caution**

- Never pry out the connection surfaces of crankcases as separating. Otherwise, the connection surfaces could be damaged and cause oil leaking.
- It have to separate the cam chain and the drive gear before pressing out the both left and right crankcases.

**Special Service Tools:**  
Crankcase remover/set



Remove the crankshaft from the right crankcase.

**⚠ Caution**

- The left and right bearings of crankshaft is to press-fit onto the crankshaft.



Remove gasket and dowel pins (2).  
Scrape gasket residues off the crankcase contact surface.

**⚠ Caution**

- Do not damage contact surface of the crankcase.
- Soap the gasket residues into solvent and the residues will be removed easily.



Remove oil seal from the left crankcase.

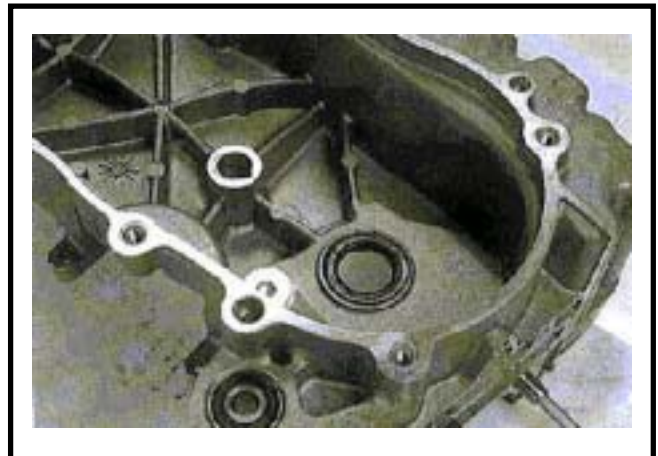

**CRANKSHAFT INSPECTION**

Measure left and right clearance of connecting rod big end.

**Service limit: Replace when it is more than 0.55 mm**

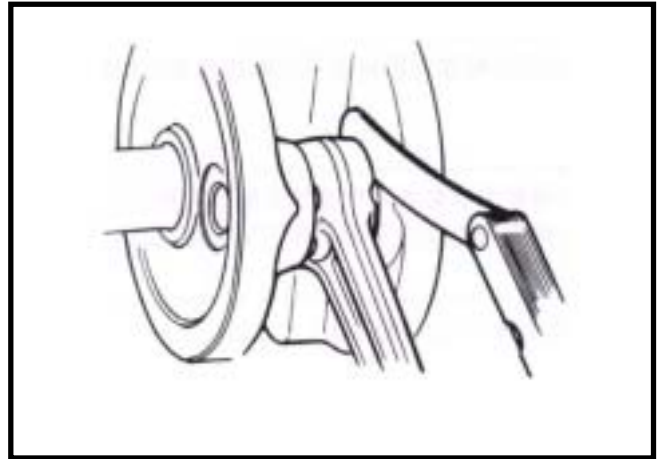

Measure the radical clearance of the big end at the vertical directions.

**Service limit : 0.05 mm**

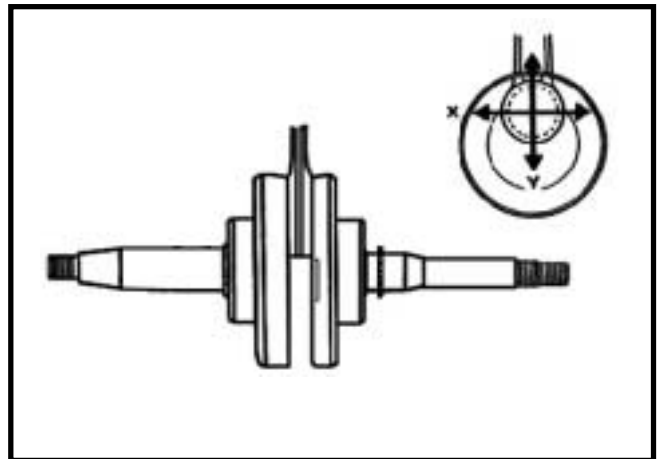

Place the crankshaft onto a V-block and measure run-out of the crankshaft with dial gauge.

**Service limit: 0.10 mm**

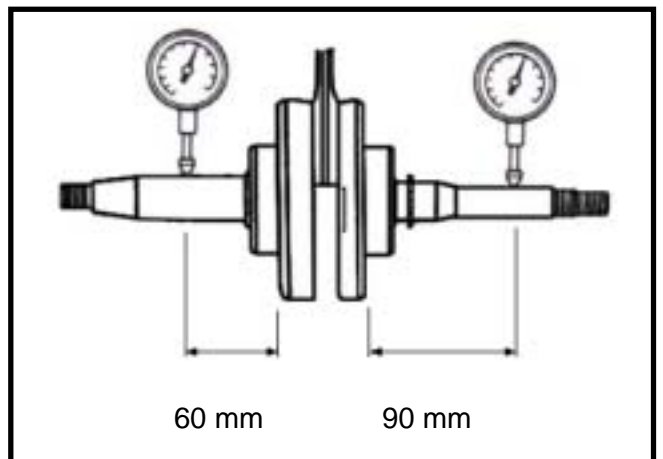

**Bearing Inspection**

Rotate the bearing with fingers and make sure the bearing can be rotated smoothly and quietly.

Check if the inner ring is connected onto the crankshaft tightly.

Replace crankshaft as a set when noise or looseness is detected.

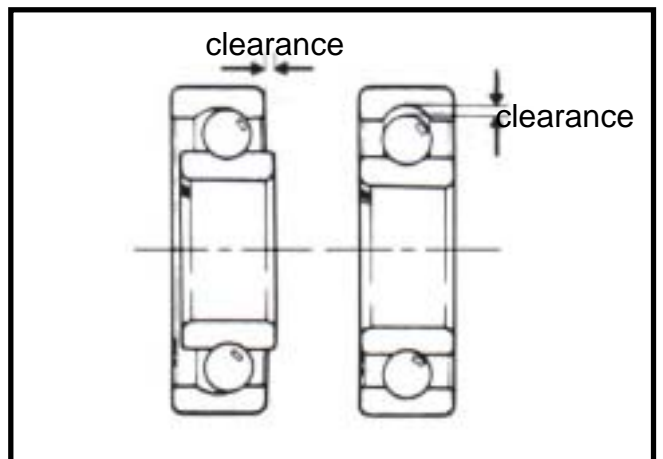

## ASSEMBLY OF CRANKCASE

Install cam chain into the chain hole of the left crankcase, and then split out the cam chain.

**⚠ Caution**

- Do not damage the cam chain as installing the crankshaft.

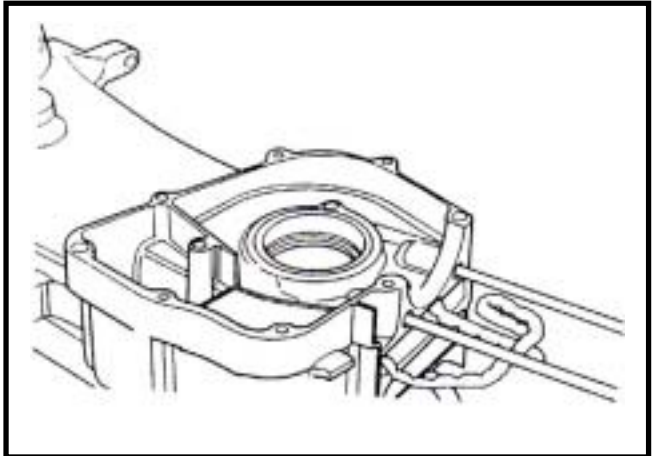

Install crankshaft into the left crankcase and then install two dowel pins and new crankcase gasket.

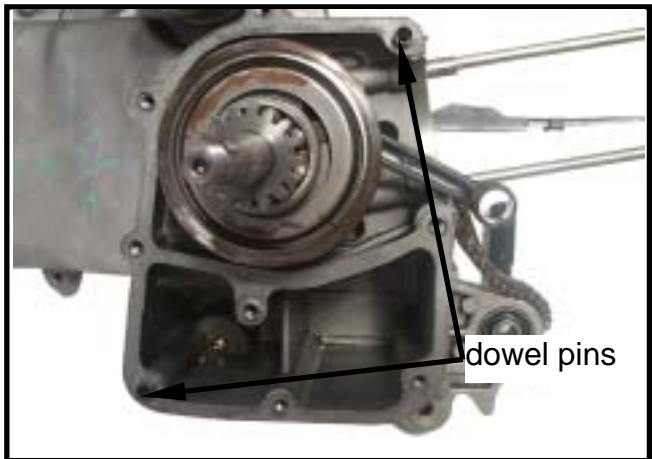

Install the right crankcase and tighten the crankcase bolts (1 bolts).

**Torque value: 1.5~2.0 kgf-m**

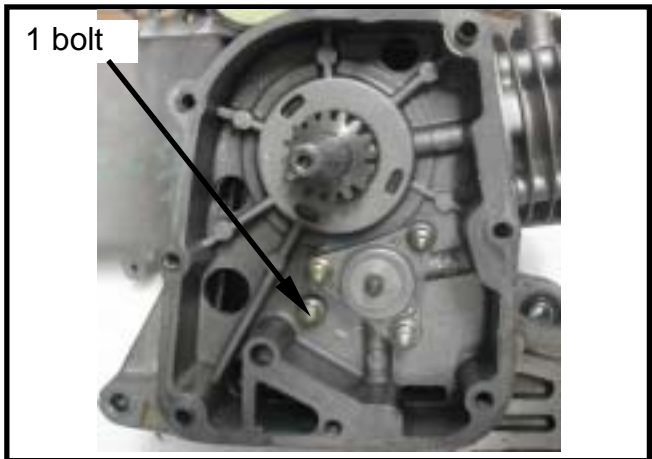

Install the cam chain tensioner. Install a new O-ring onto the mounting bolt of the chain tensioner. Apply some oil on the O-ring and tighten the bolt.

**Torque value: 0.8~1.2 kgf-m**

**⚠ Caution**

- The O-ring must be installed into the bolt's groove.

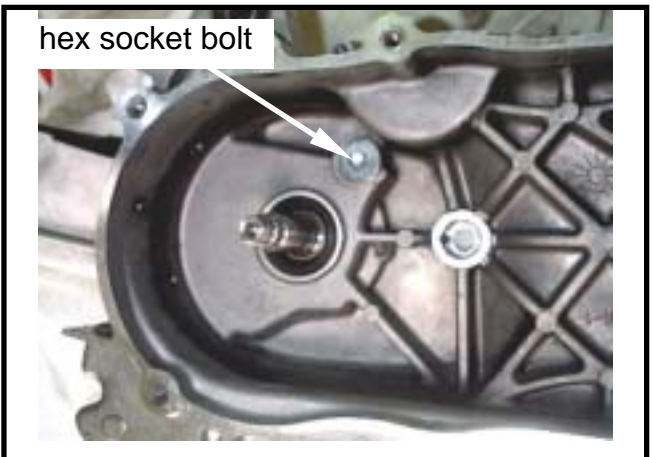



Apply with some grease onto the oil seal lip and then install it onto the left crankcase.



Press-fit the oil seal to specified position with the oil seal installer (25x37x6).

**Special service tools: the oil seal installer (25x37x6)**



MAINTENANCE INFORMATION.....	12-2	BODY COVER/REAR CENTER COVER/REAR FENDER .....	12-8
HANDLE COVER .....	12-3	FRONT CENTER COVER.....	12-10
FRONT COVER.....	12-4	LUGGAGE BOX .....	12-10
FRONT UNDER COVER.....	12-5	FLOOR PANEL .....	12-10
FRONT INNER BOX A / B.....	12-6		

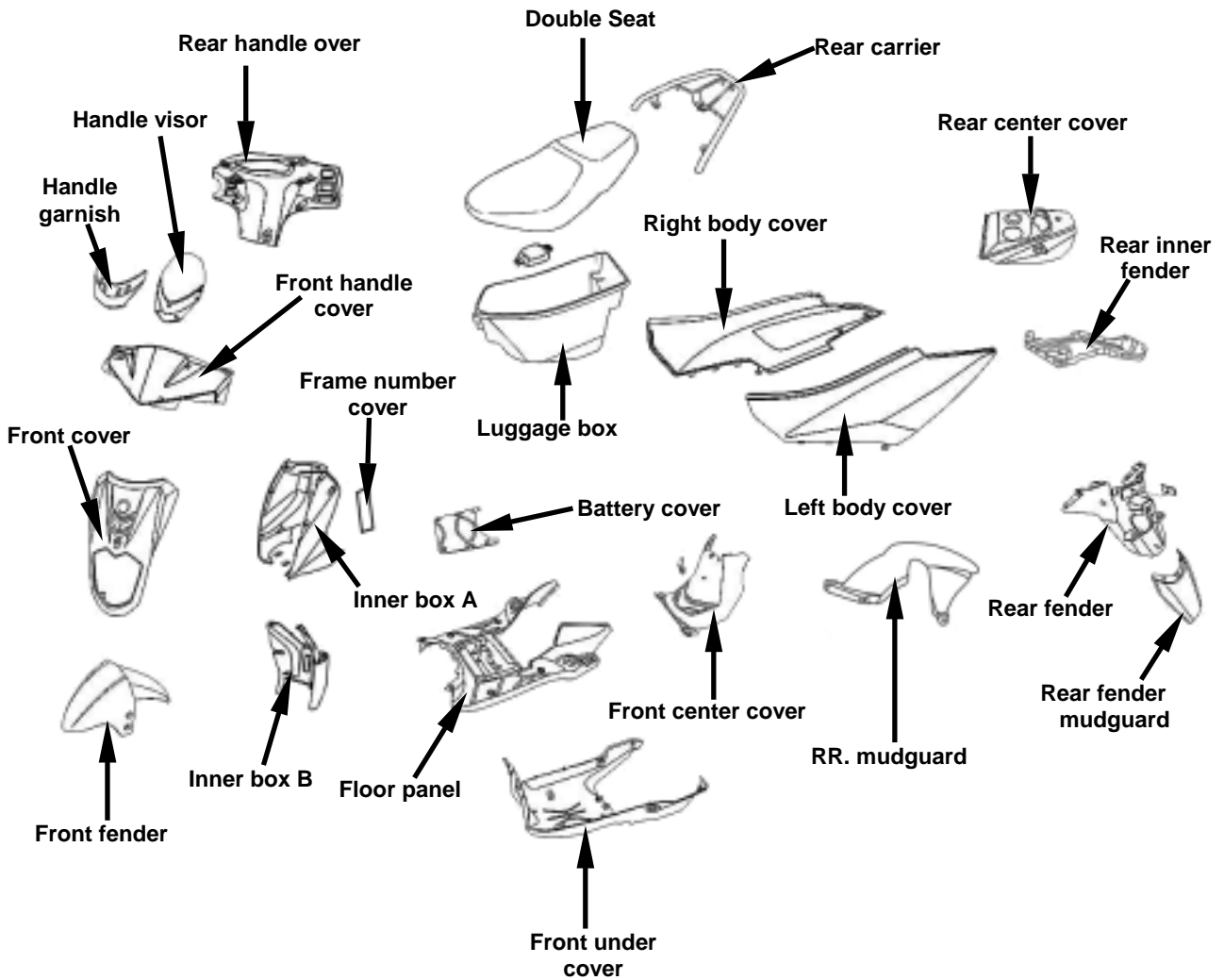

**MAINTENANCE INFORMATION**

Body covers disassemble sequence:

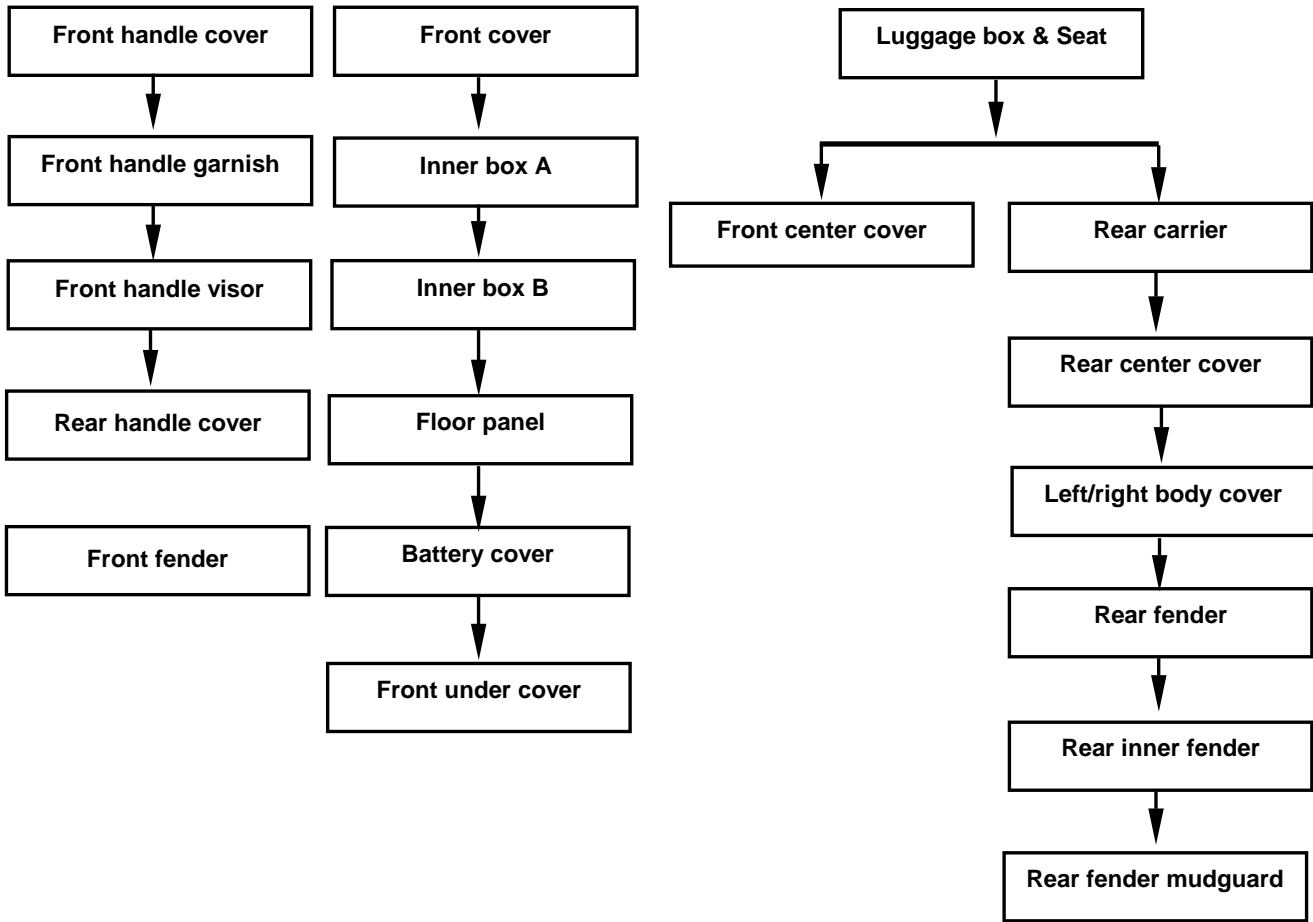

- Be careful not to damage various covers in disassembly or re-assembly operation.
- Never injure hooks molded on the body covers in disassembly or re-assembly operation.
- Align the buckles on the guards with slot on the covers.
- Make sure that each hook is properly installed during the assembly.
- Never compact forcefully or hammer the guard and the covers during assembly.

**HANDLE COVER**

**Removal:**

Remove 1 lower mounting screw of the handle front cover.



Remove the mounting screws (4 screws) between the front handle cover and the rear handle cover.

Remove the mounting screws (1 screw) between the rear handle cover and the frame.

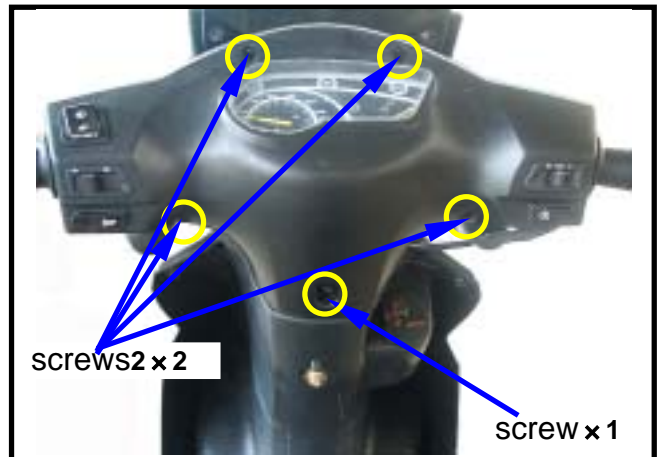

Removed the left/right turn signal light connectors.

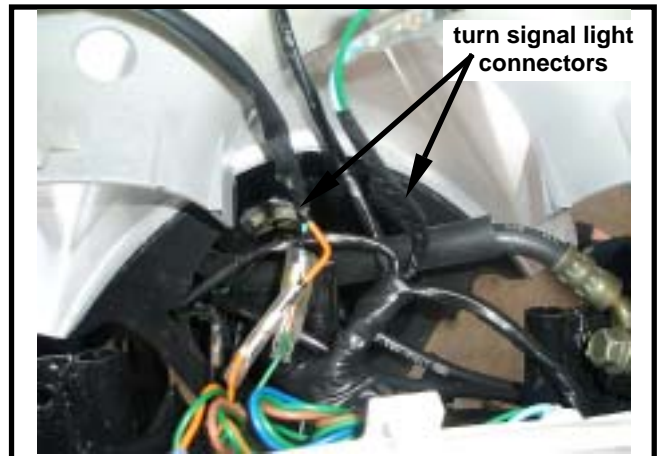

Remove the front handle cover.  
Remove the speedometer cable.  
Remove the handlebar rear cover. (2 screws)  
Removed the brake switch connectors.

**Installation:**

Install according to the reverse procedure of removal.

**⚠ Caution**

With the clipper to fix the end-section of the handlebar cover. Do not pull it forcedly to avoid to breaking the hooks.

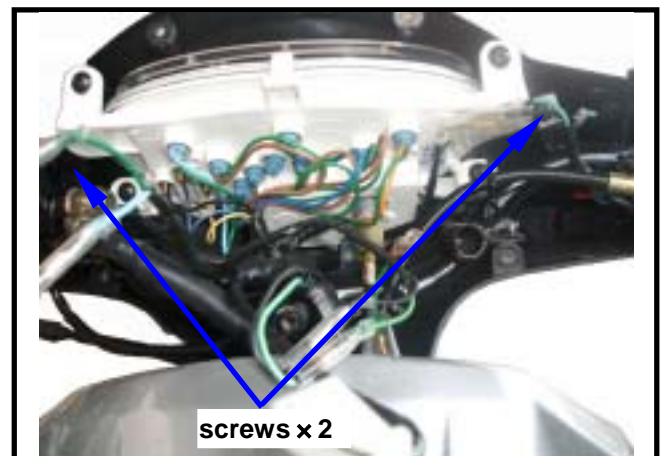

### FRONT COVER

#### Removal

Remove the 8 mounting screws of front cover from the inner box A.

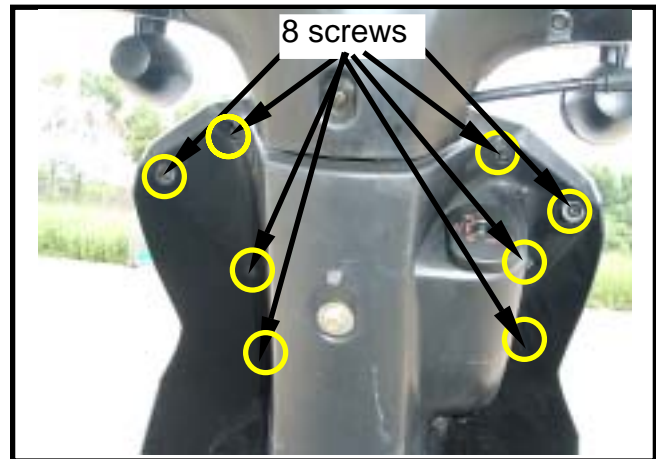

Remove the 2 mounting screws between the front cover and the inner box .

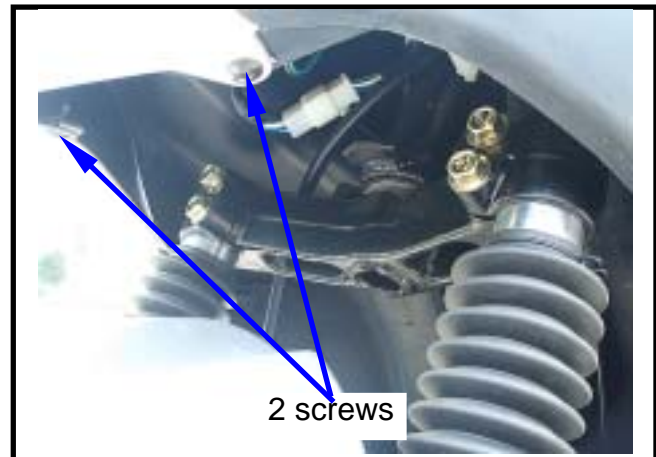

Remove the 1 mounting bolt of front cover from the frame.

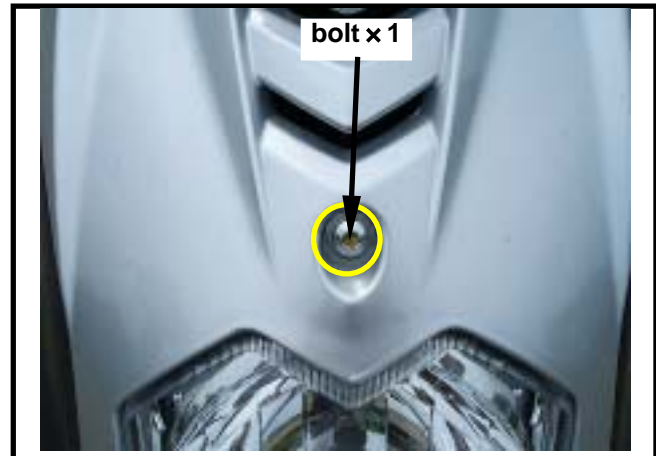

Remove the headlight wire connector and then remove the front cover.

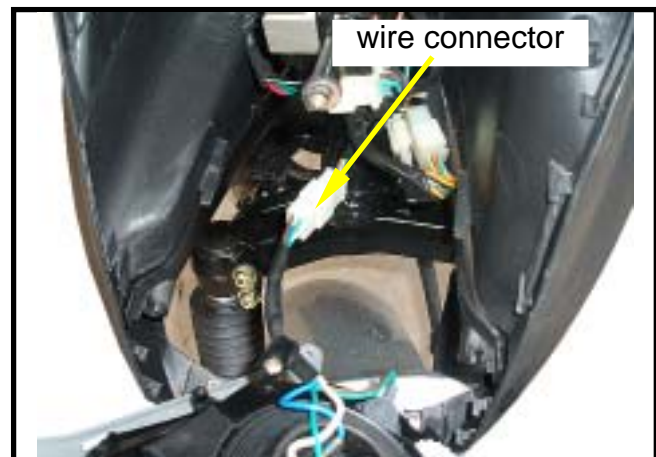

#### Installation

Install according to the reverse procedure of removal.

**FRONT UNDER COVER****Removal**

Remove the 2 mounting screws between the inner box B and the floor panel.

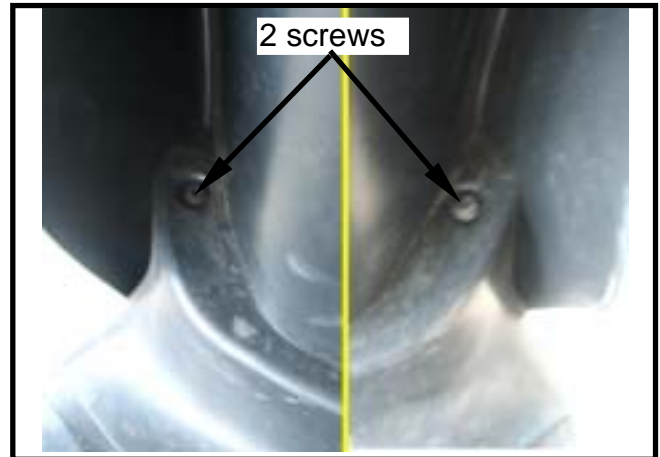

Remove the 4 mounting screws between the front under cover and the inner box B.

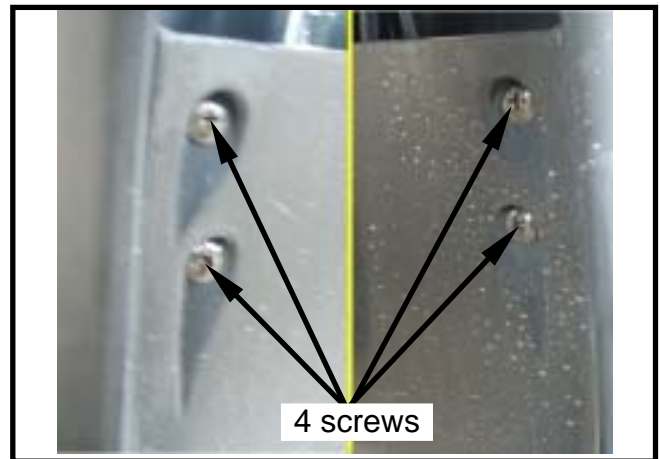

Remove the 2 mounting bolts between the front under cover and frame.

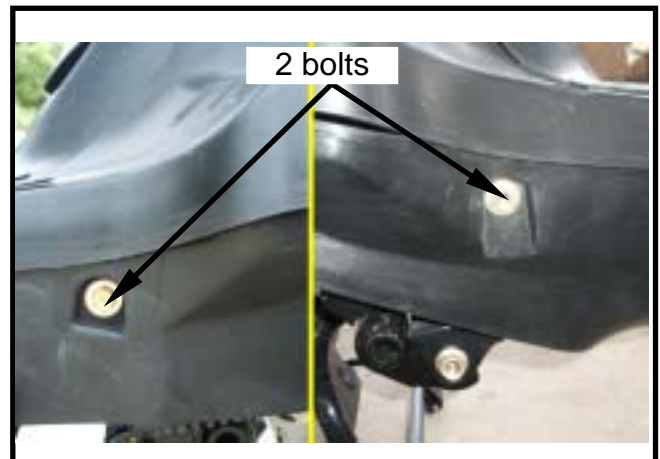

Remove the 2 mounting screws between the front under cover and the floor panel.

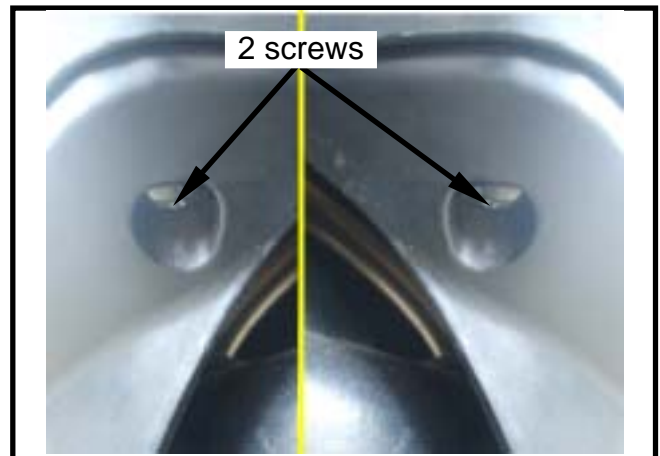
**Installation**

Install according to the reverse procedure of removal.

## FRONT INNER BOX A

### Removal

Remove the 8 mounting screws of front cover from the inner box A.

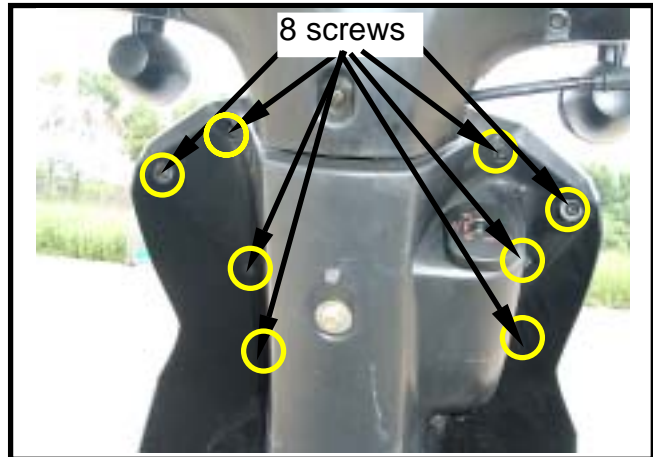

Remove the screw on the front inner box.

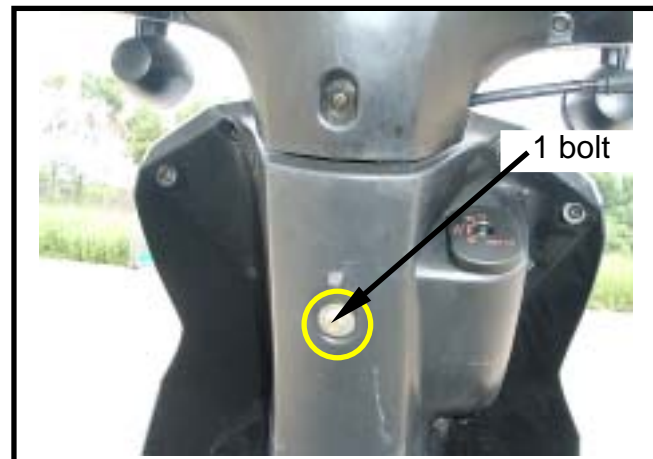

Remove the front cover.  
Remove the screw on the main switch.  
Remove the main switch cover.

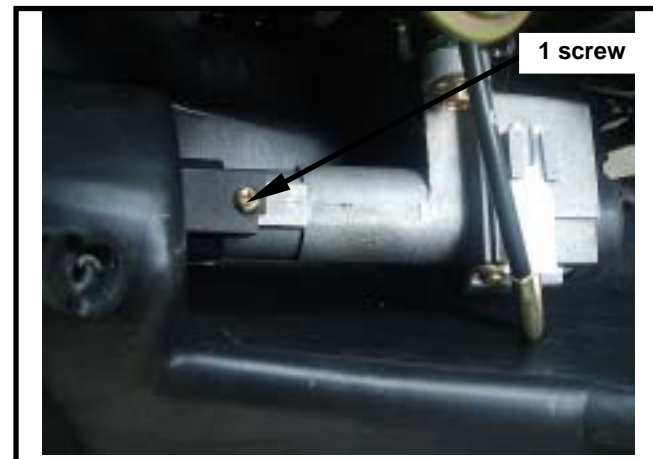

Remove the 4 screws between the inner box A and the inner box B.

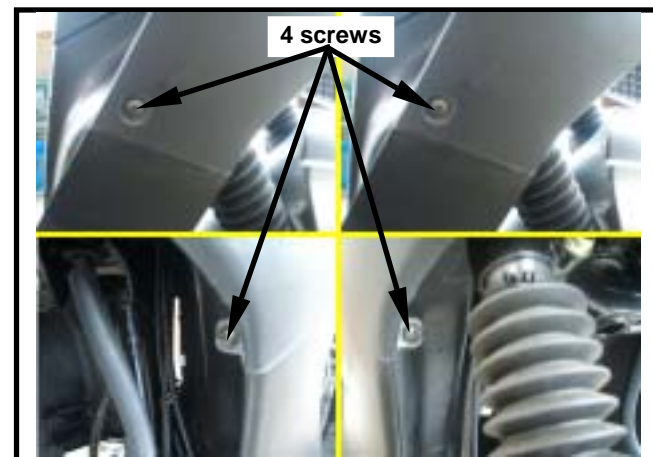

Remove the 2 mounting screws between the inner box B and the floor panel.

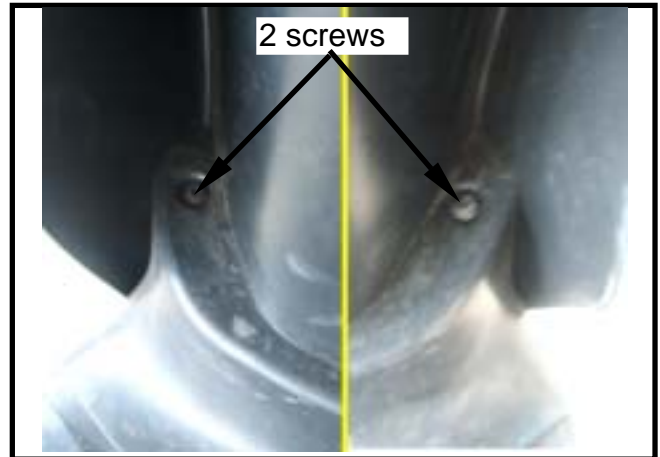

Remove the 4 mounting screws between the front under cover and the inner box B.

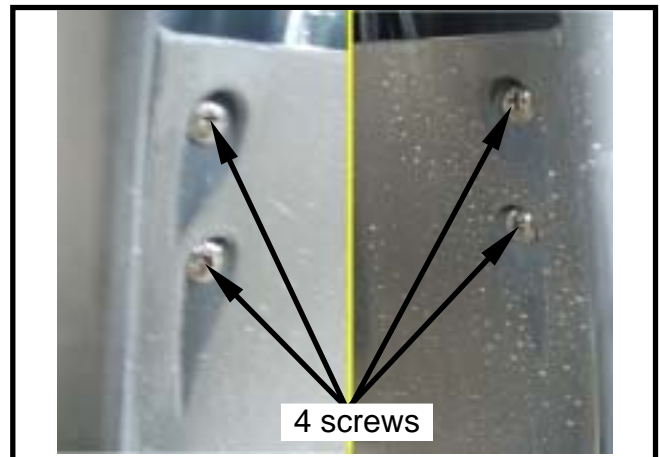

Remove the front inner box A and the front inner box B.

Remove the screw between the inner box A and the inner box B.

Remove the front inner box A.  
Remove the front inner box B.

### Installation

Install the inner box A and the front inner box B according to the reverse procedure of removal.





### BODY COVER/REAR CENTER COVER/REAR FENDER

#### Removal

Open the seat.

Remove the luggage box. (4 bolts)



Remove the rear carrier. (3 bolts)

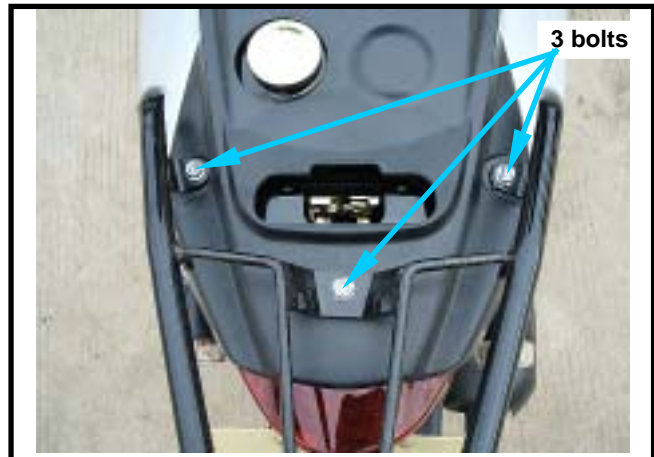

Remove the 2 mounting bolts of the rear fender.

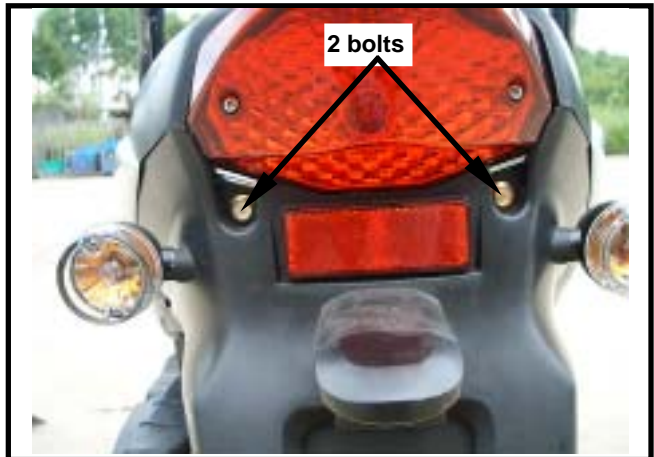

Remove the 2 mounting screws between the body cover and the floor panel.



Remove the body cover, rear center cover and rear fender.

Remove the 4 screws between the rear center cover and the left/right body cover.

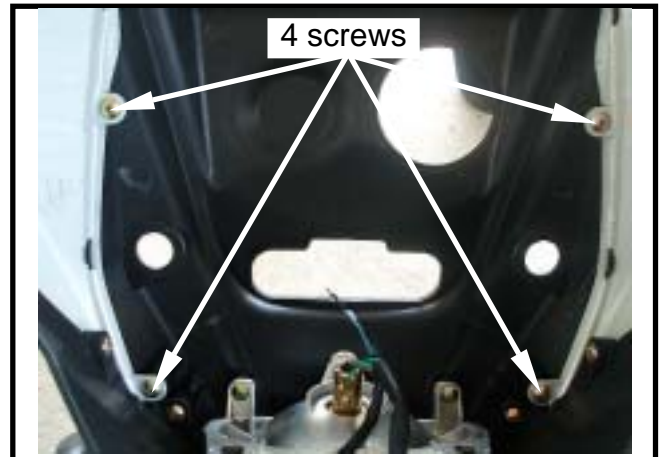

Remove the 4 screws between the rear fender and the left/right body cover.

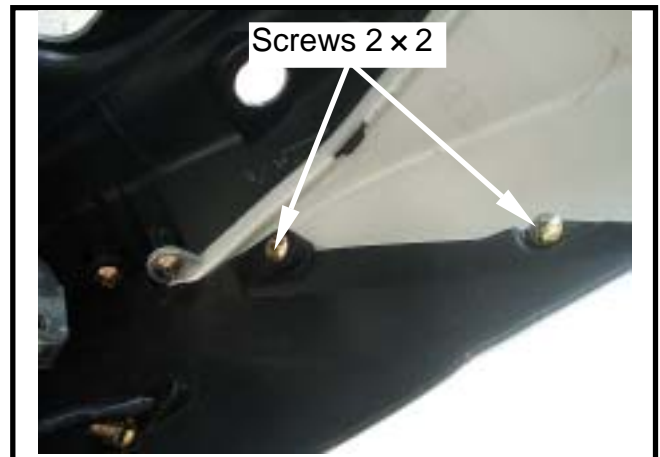

Remove the 2 screws between the rear fender and the rear center cover.

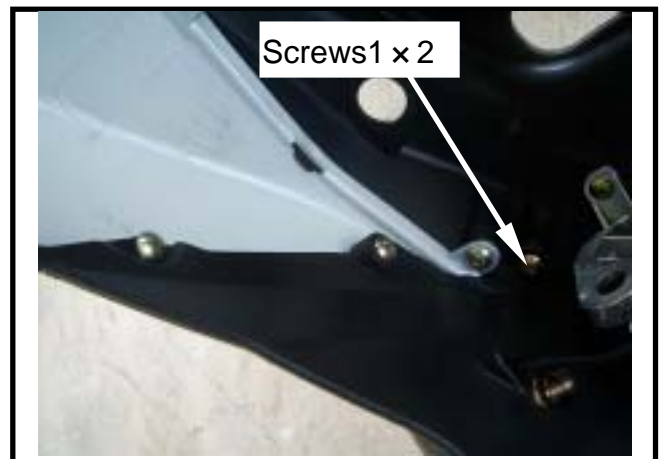

Remove the rear fender.  
Remove the rear center cover.  
Remove the left/right body cover.

### Installation

Install the body cover, rear center cover and rear fender according to the reverse procedure of removal.

## FRONT CENTER COVER

### Removal

Remove the luggage box.  
 Remove the front center cover mounting screw.  
 Remove the front center cover mounting bolt.

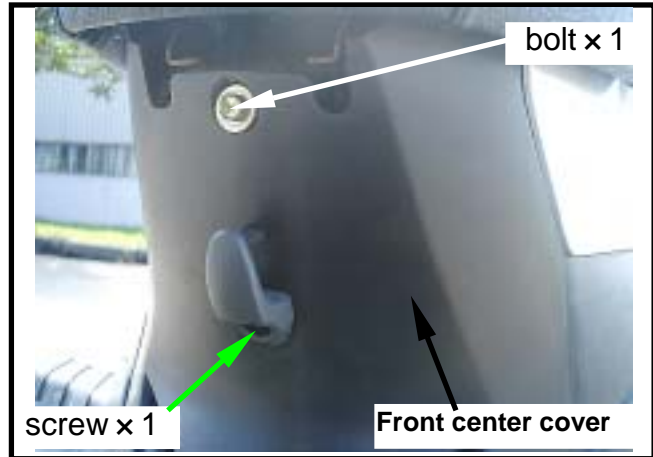

Remove the front center cover.

### Installation

Install the cover according to the reverse procedure of removal.



## LUGGAGE BOX

### Removal

Open the seat.  
 Remove the 4 bolts from the luggage box.  
 Remove the luggage box and the double seat.

### Installation

Install the luggage box according to the reverse procedure of removal.

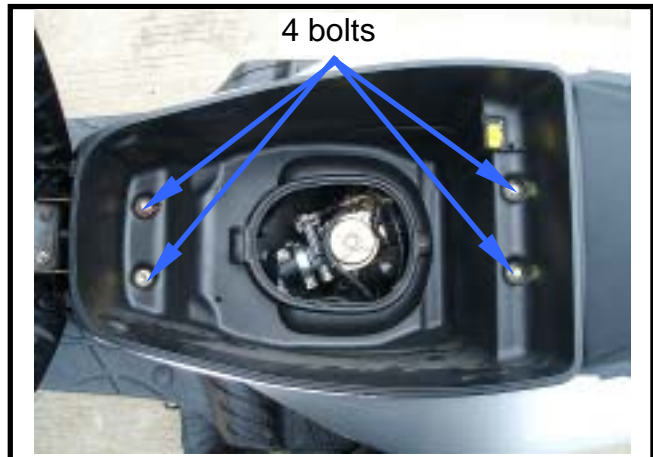

## FLOOR PANEL

### Removal

Remove the 4 bolts from the luggage box.  
 Remove the luggage box and the double seat.  
 Remove the front center cover.  
 Remove the 2 screws between the inner box B and the floor panel.  
 Remove the 4 floor panel mounting bolts.

### Installation

Install the floor panel according to the reverse procedure of removal.

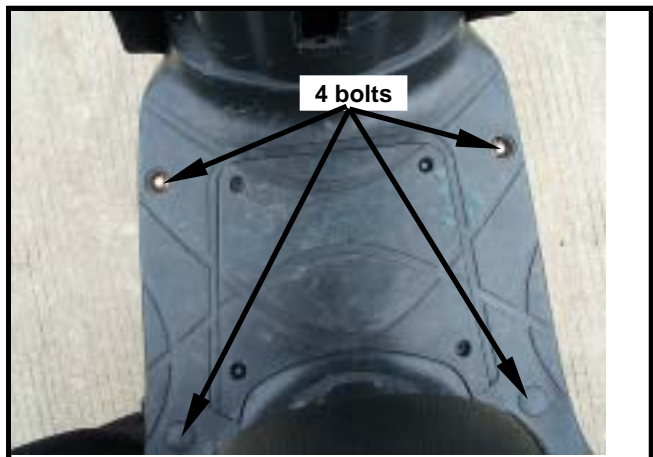

MECHANISM DIAGRAM-FRONT DISC BRAKE SYSTEM.....	13-1	BRAKE CALIPER .....	13-8
MECHANISM DIAGRAM-FRONT DRUM BRAKE SYSTEM .	13-2	BRAKE DISC .....	13-9
MECHANISM DIAGRAM-REAR DRUM BRAKE SYSTEM ..	13-3	BRAKE MASTER CYLINDER .....	13-9
<b>MAINTENANCE INFORMATION .....</b>	<b>13-4</b>	DRUM BRAKE-DRUM .....	13-12
<b>TROUBLE DIAGNOSIS .....</b>	<b>13-5</b>	BRAKE LING .....	13-12
HYDRAULIC BRAKE SYSTEM INSPECTION.....	13-6	BRAKE PANEL.....	13-13
BRAKE FLUID REPLACEMENT/AIR-BLEED .....	13-7		

**MECHANISM DIAGRAM**

**Front Disc Brake System**

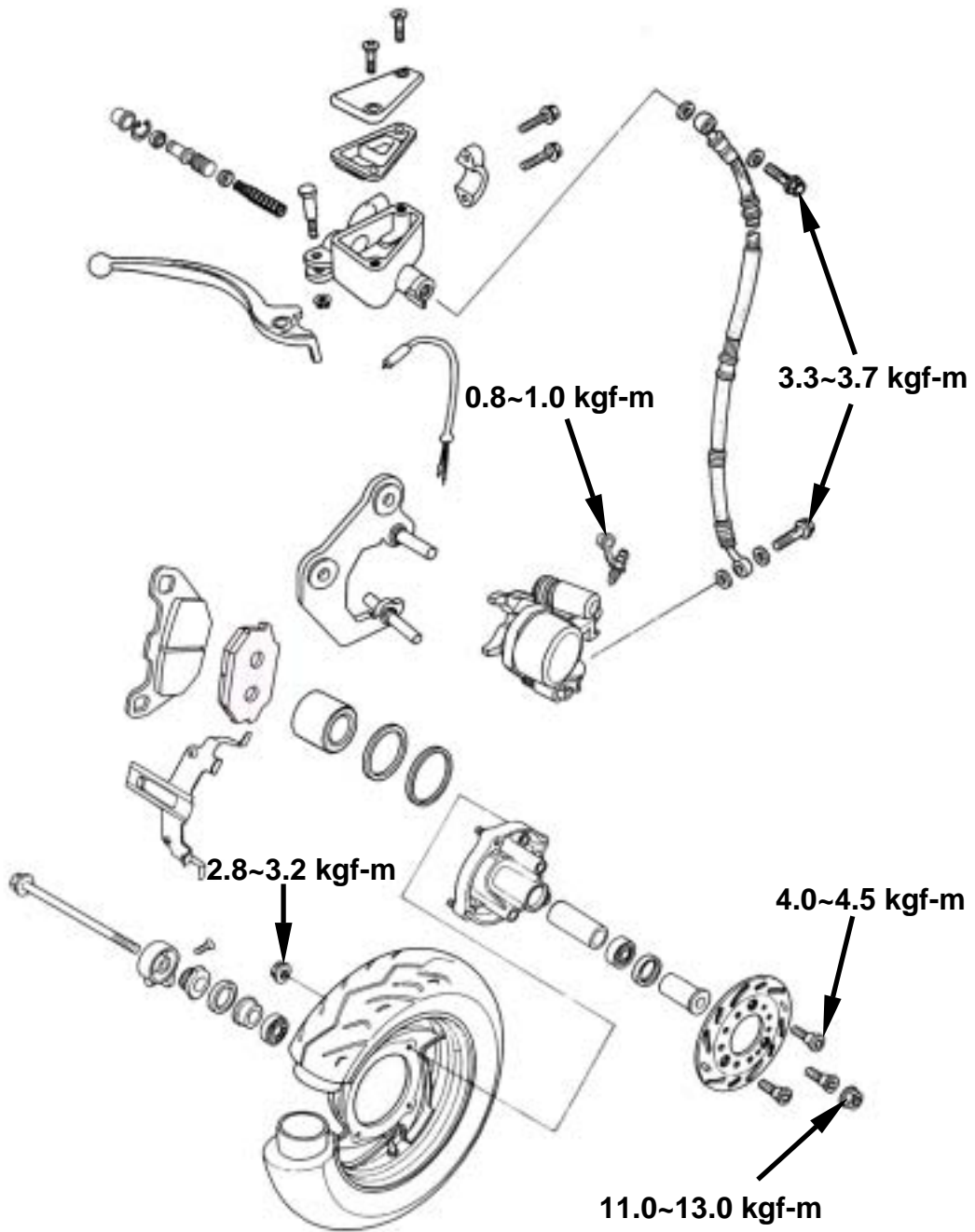

MECHANISM DIAGRAM  
Front Drum Brake System

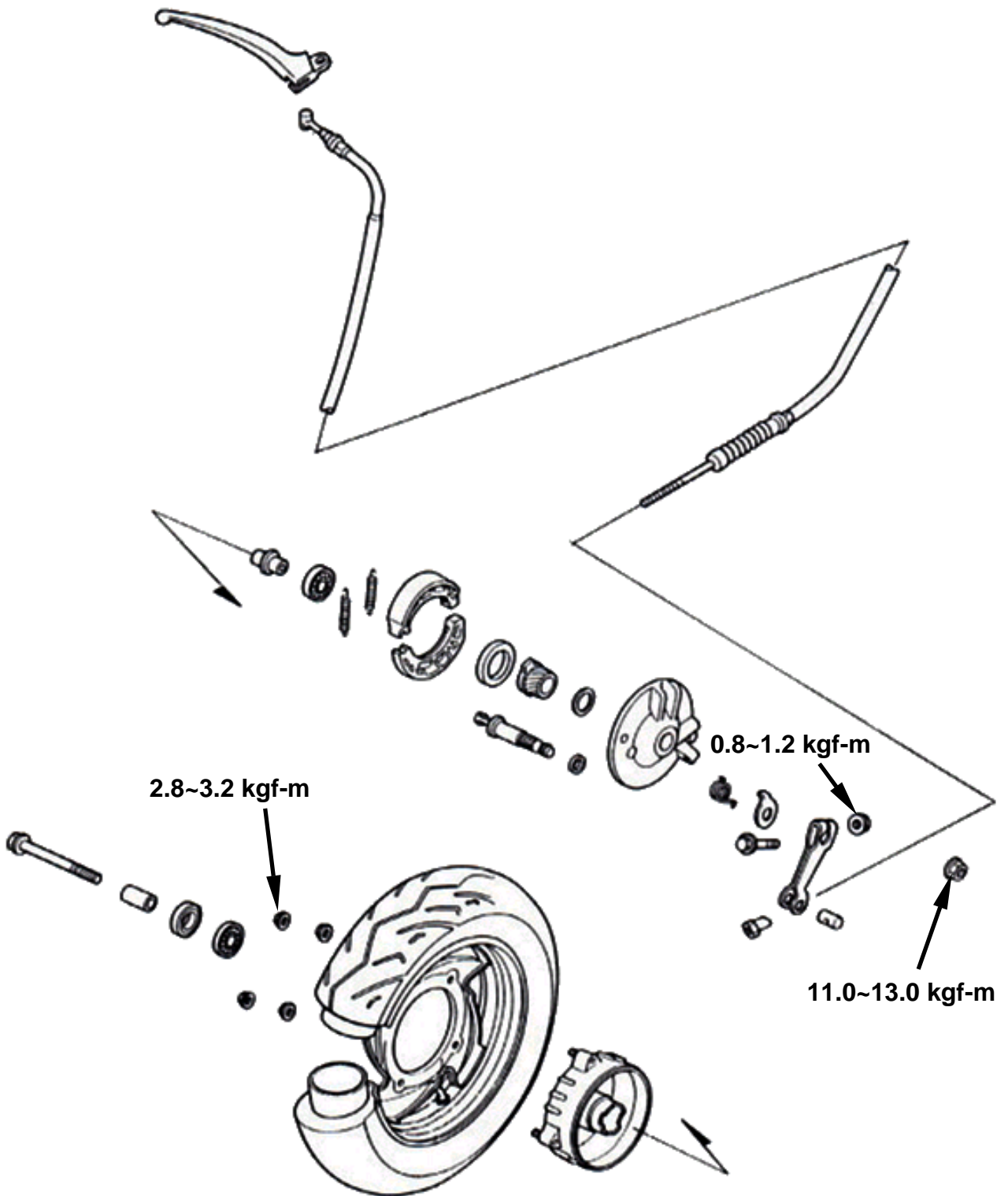

**MECHANISM DIAGRAM**  
**Rear Drum Brake System**

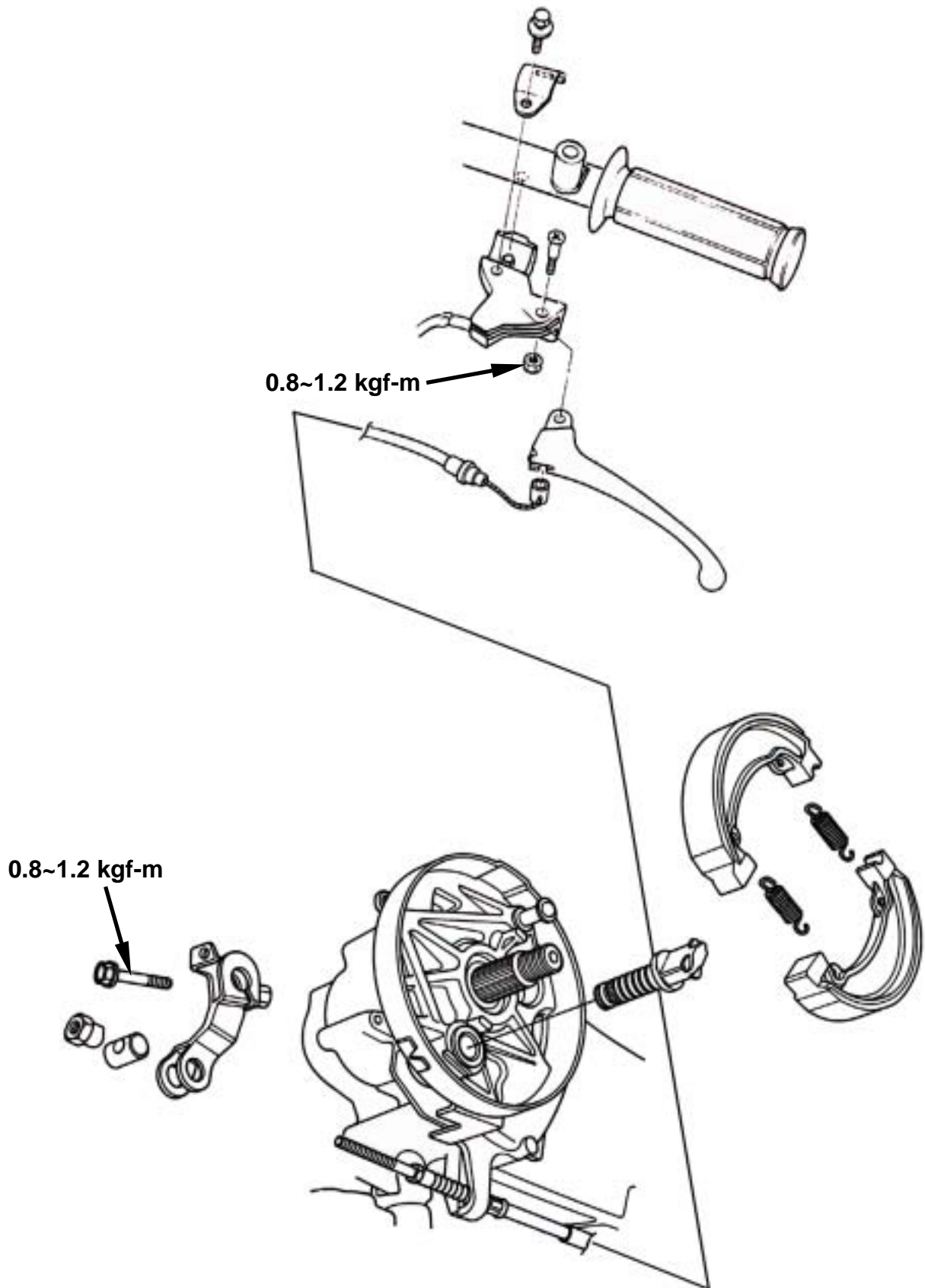

## MAINTENANCE INFORMATION

### Precautions in Operation

 **Caution**

Installing lining dusts may cause disorders of respiration system or cancer, therefore, never use air hose or dry brush to clean brake parts. Use vacuum cleaner or other authorized tool instead.

- The brake caliper can be removed without removing the hydraulic system.
- After the hydraulic system is removed, or the brake system is felt to be too soft, bleed the hydraulic system.
- While refilling brake fluid, care should be taken not to let the foreign material entering into the brake system.
- Do not spill brake fluid on the painted surfaces, plastic or rubber parts to avoid damage.
- Check the operation of the brake system before you go.

### Specifications

Unit: mm

Item	Standard	Limit
The thickness of front brake	<b>3.50</b>	<b>2.00</b>
Front brake disc eccentricity	<b>0.15</b>	<b>0.30</b>
Master cylinder inner diameter	<b>25.40</b>	
ID of front & rear brake drums	<b>130.00</b>	<b>131.00</b>
OD of front brake disc	<b>130.00</b>	
Thickness of front disc brake		As brake ling mark
Thickness of front drum brake		2mm or As brake ling mark
Thickness of rear brake lining		2mm or As brake ling mark

### Torque values

Bolt for front brake arm	0.8~1.2kgf-m
Bolt for rear brake arm	0.8~1.2kgf-m
Brake hose bolt	3.3~3.7kgf-m
Bolt for brake caliper	3.1~3.5kgf-m
Air-bleed valve	0.8~1.0kgf-m

**TROUBLE DIAGNOSIS****DISC BRAKE****Soft brake lever**

1. Air inside the hydraulic system
2. Hydraulic system leaking
3. Worn master piston
4. Worn brake pad
5. Poor brake caliper
6. Worn brake lining/disc
7. Low brake fluid
8. Blocked brake pipe
9. Warp/bent brake disc
10. Bent brake lever

**Hard operation of brake lever**

1. Blocked brake system
2. Poor brake caliper
3. Blocked brake pipe
4. Seized/worn master cylinder piston
5. Bent brake lever

**DRUM BRAKE****Poor brake performance**

1. Improper brake adjustment
2. Worn brake lining
3. Worn brake drum
4. Worn brake cam
5. Improper brake lining installation
6. Seized brake cable
7. Dirty brake lining
8. Dirty brake drum
9. Brake pad worn in brake cam area.
10. Poor contact between brake arm and camshaft indent

**Uneven brake**

1. Dirty brake lining/disc
2. Poor wheel alignment
3. Clogged brake hose
4. Deformed or warped brake disc
5. Restricted brake hose and fittings

**Tight brake**

1. Dirty brake lining/disc
2. Poor wheel alignment
3. Deformed or warped brake disc

**Brake noise**

1. Dirty lining
2. Deformed brake disc
3. Poor brake caliper installation
4. Imbalance brake disc or wheel

**Tight operation or low return speed of brake lever**

1. Worn/broken/crack return spring
2. Worn drum
3. Dirty brake lining
4. Brake seized caused from dirty brake drum
5. Seized brake cable
6. Worn brake cam
7. Improper brake lining installation

**Brake noise**

1. Worn brake lining
2. Worn drum
3. Dirty brake lining
4. Dirty brake drum



**HYDRAULIC BRAKE SYSTEM INSPECTION**

**Inspection**

Visual inspect for brake fluid leaking or damage. Check if brake hose connection loosen with wrench and turn the handlebar from right to left motion or press down the shock absorber to check if there is something is interfered with the brake system or brake components.

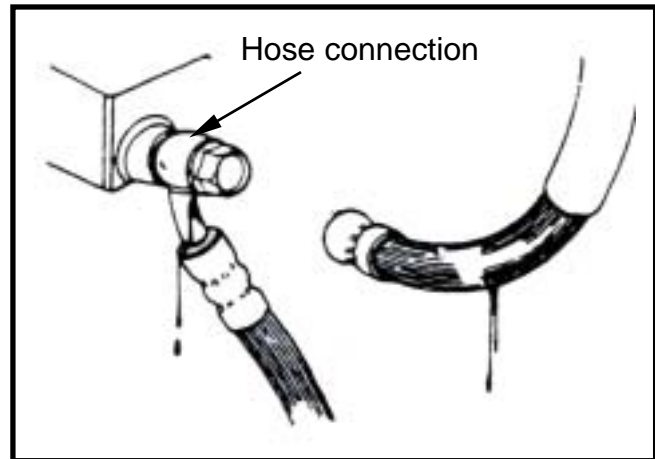

Operate the brake system and check the brake lining. Check the front brake from front side, and replace the brake lining with new one when the brake lining wear limitation groove reaches to the brake disc.

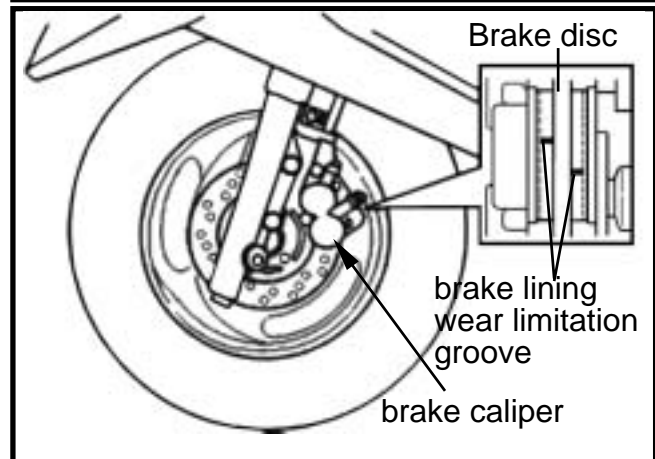

Park the motorcycle on a flat ground and check its brake fluid level. Recommended brake fluid: WELLRUN DOT 3 brake fluid

**CAUTION**

- The fluid level will not be correct if parking the motorcycle in title or just parking. It has to waiting for around 3~5 minutes.
- Never use faked brake fluid to prevent from chemical reaction.
- It has to apply with same brand brake fluid to sure the brake performance.

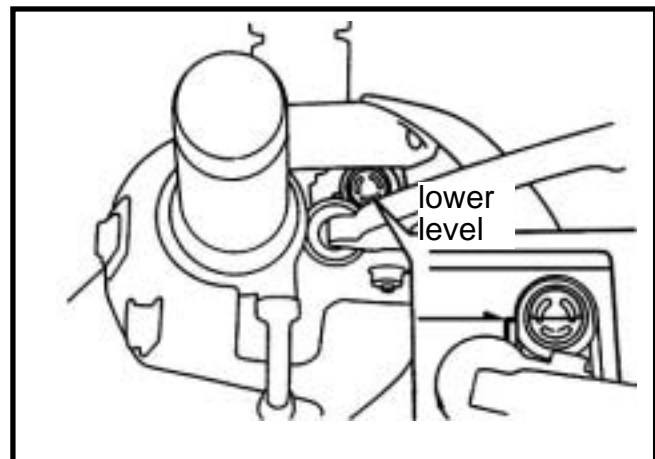

**Brake Fluid Add**

Turn the handlebar to let the master cylinder in horizontal position before removed the master cylinder cap. Place a rag onto painting, plastic or rubber components when conduct brake system maintenance.

**CAUTION**

- Do not over the upper level when adding brake fluid and avoid to spilling brake fluid on painted surfaces, plastic or rubber components to result in their damages.

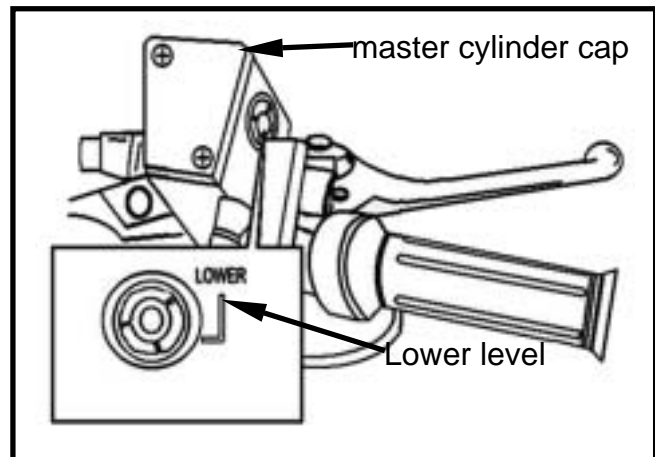

Remove the master cylinder cap and diaphragm.

Add good quality brake fluid and it has to add same brand brake fluid into the master cylinder. Clean dirty brake disc.

### ⚠ CAUTION

The dirty brake lining or disc will reduce the brake performance. The mixed non-compatible brake fluid will reduce brake performance. Foreign materials will block the system causing brake performance to be reduced or totally lost.

## BRAKE FLUID REPLACEMENT/ AIR-BLEED

Connect drain hose to drain valve. Open the drain valve on the caliper and hold and release the brake lever alternatively until the old brake fluid is entirely drained out. Close the drain valve and add specified brake fluid into the brake master cylinder.

### ⚠ CAUTION

To reuse the spent brake fluid will effect brake performance.

Connect one end of transparent hose to the drain valve, and put the other end into a container.

Open the drain valve around 1/4 turns, and at the same time hold the brake lever until there is no air bubble in the drain hose and also feeling resistance on the brake lever. Close the drain valve when finishing the brake system refilling fluid procedure, and operate the brake lever to check whether air bubble is in brake system or not. If brake is still soft, please bleed the system as described below.

1. Tightly hold the brake lever and open the drain valve around 1/4 turns, and then close the valve.

### ⚠ CAUTION

- Do not release the brake lever before the drain valve is closed.
- Always check the brake fluid level when carrying out the air bleeding procedure to avoid air entering into the system.

2. Slowly release the brake lever, and wait for a few seconds until it reaches its top position.

3. Repeat the steps 1 and 2 until there is no air bubble at the end of the hose. Tightly close the drain valve.

4. Make sure the brake fluid is in the UPPER level of the master cylinder, and refill the fluid if necessary.

5. Cover the cap.

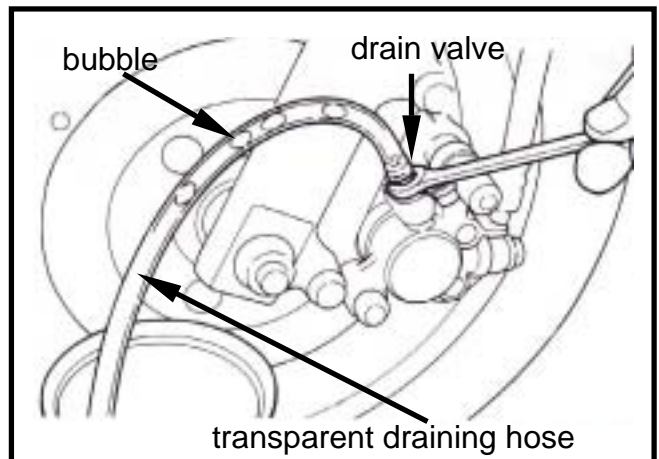
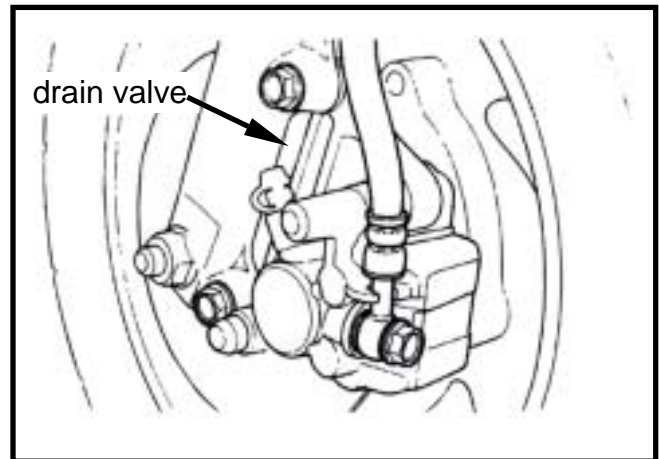
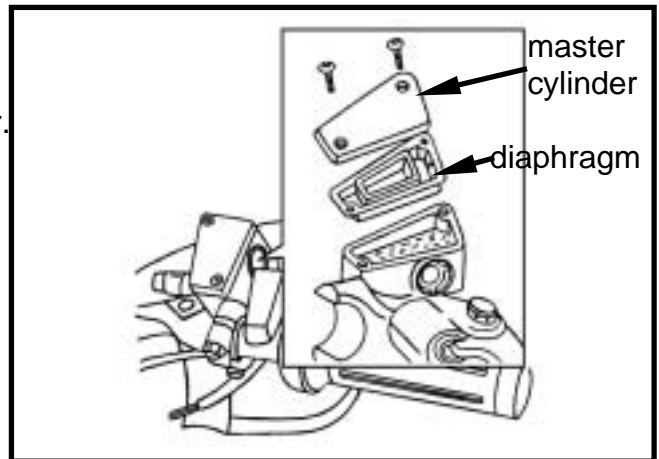

## BRAKE CALIPER

### Removal

Place a container under the brake caliper, and loosen the brake hose bolt and finally remove the brake hoses.

### ⚠ CAUTION

- Do not spill brake fluid on painted surfaces.

Remove two caliper bolts and the caliper.

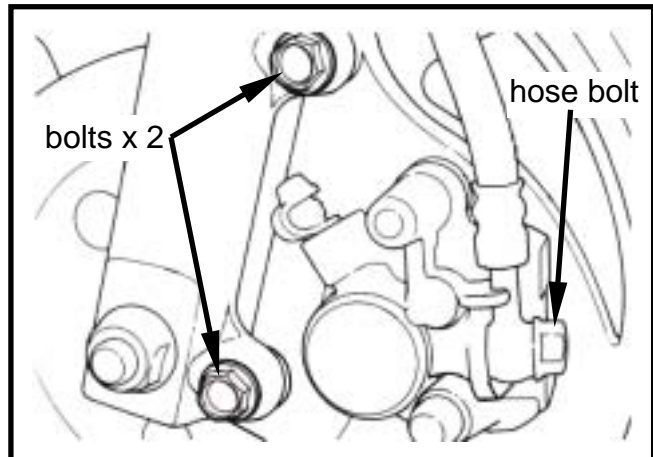

Make sure the brake lining condition. Replace the lining if the brake lining wear limitation groove close to the brake disc.

### Brake Lining Replacement

Compress the caliper and let the brake lining out of the caliper mounting plate. Compress the brake lining locking spring. Remove the inner brake lining firstly and then remove the outer brake lining.

Compress the brake caliper at first as installation. Install the inner brake lining firstly, and then install the outer brake lining.

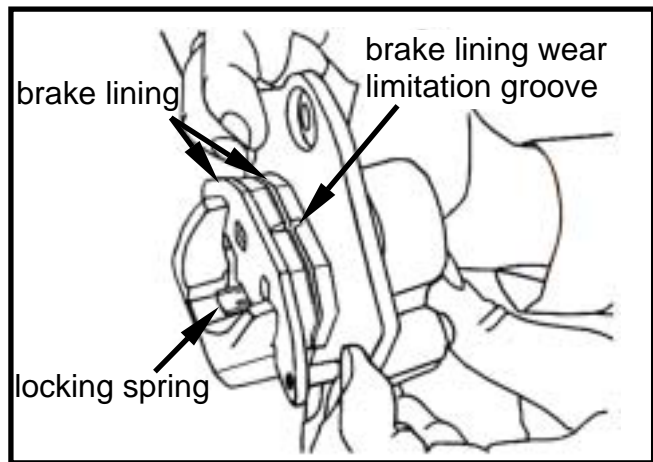

### INSTALLATION

Install the brake caliper and tighten the attaching bolts securely.

**Torque: 3.3 kgf-m**

### ⚠ CAUTION

- Use M8 x 35 mm flange bolt only.
- Long bolt will impair the operation of brake disc.

Tighten the lining guide bolt.

**Torque: 1.8 kgf-m**

Use two seal washers and hose bolts to lock the hose and brake caliper in place.

**Torque: 3.5 kgf-m**

Refill up the brake fluid to the reservoir and make necessary air bleeding.

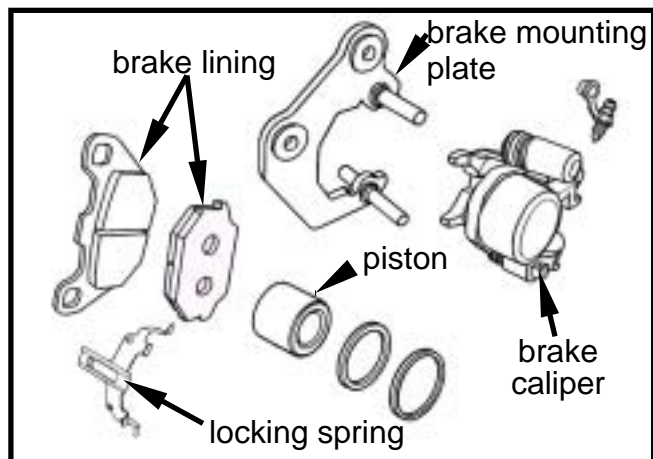

**BRAKE DISC**

**Inspection**

Visually check the brake disc for wear or break.

Measure the thickness of the disc at several places. Replace the disc if it has exceeded the service limit.

**Allowable limit: 2.0 mm**

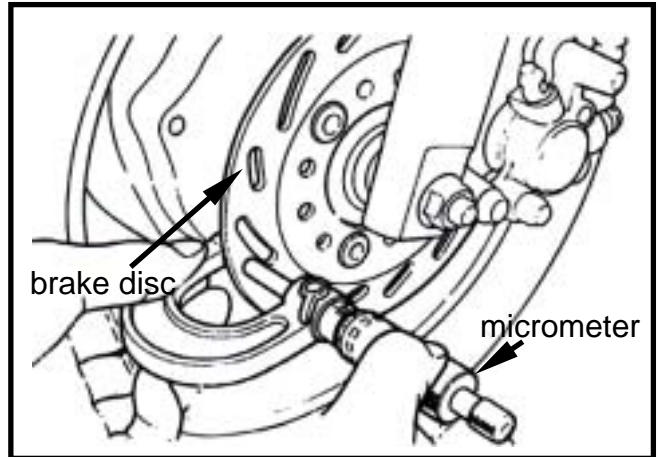

Remove the brake disc from wheel. Check the disc for deformation and bend.

**Allowable limit: 0.30 mm**

**CAUTION**

- Do not let grease touch to the brake disc that will cause brake performance.
- Do not clean the brake lining with air gun. Operator should wear mask & glove and use vacuum cleaner to clean the brake lining.

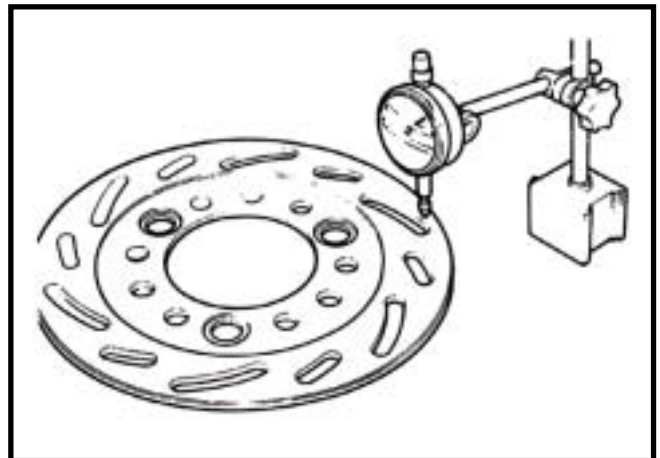

**BRAKE MASTER CYLINDER**

**Removal**

**CAUTION**

Do not let foreign materials enter into the cylinder.

**CAUTION**

The whole set of master cylinder, piston, spring, diaphragm and circlip should be replaced after removal.

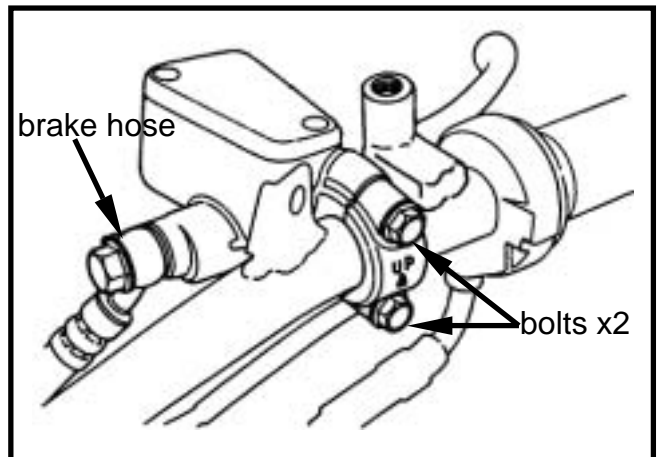

- Remove the front and rear handlebar guards.
- Remove the leads of brake lamp switch.
- Drain out the brake fluid.
- Remove the brake lever from the brake master cylinder.
- Remove the brake hose.
- Remove the master cylinder seat and the master cylinder.
- Remove the rubber pad.
- Remove the circlip.
- Remove the piston and the spring.
- Clean the master cylinder with recommended brake fluid.

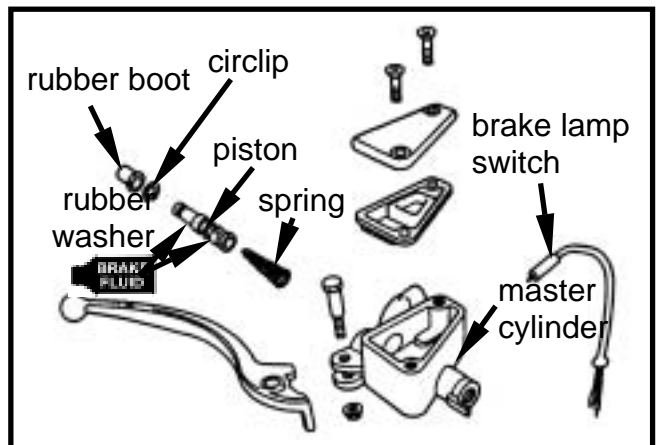

## Inspection

Check the master cylinder for damage or scratch. Replace it if necessary.  
 Measure the cylinder inner diameter at several points along both X and Y directions.  
 Replace the cylinder if the measured values exceed allowable limit.

**Allowable limit: 11.055 mm**

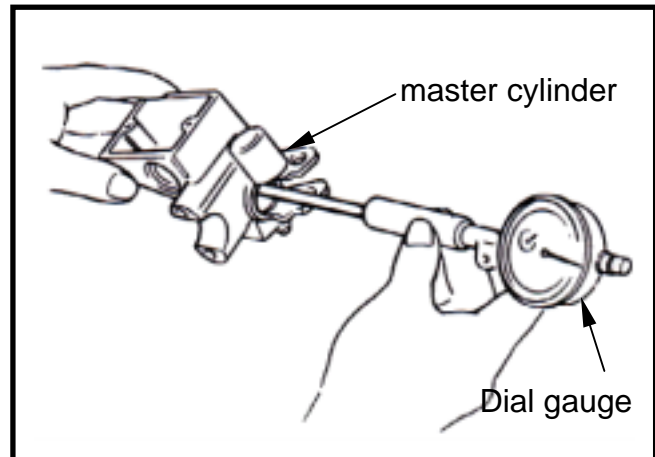

Measure the outer diameter of the piston.  
 Replace the piston if its measured value exceeds allowable limit.

**Allowable limit: 10.945 mm**

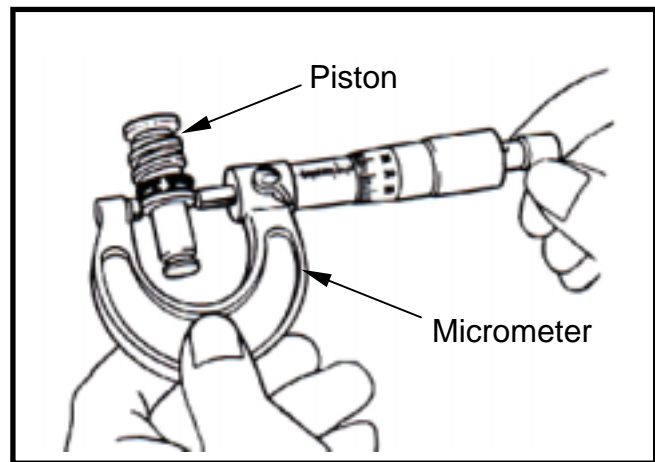

## Assembly

### ⚠ CAUTION

- It is necessary to replace the whole set comprising piston, spring, piston cup, and circlip.
- Make sure there is no dust on all components before assembling.

Apply clean brake fluid to the piston cup, and then install the cup onto the piston.  
 Install the larger end of the spring onto the master cylinder.

The master cup's cavity should be face inside of master cylinder when installing the master cup.

Install the circlip.

### ⚠ CAUTION

- Never install cup lip in the opposite direction.
- Make sure the circlip is seated securely in the groove.

Install the rubber pad into groove properly.

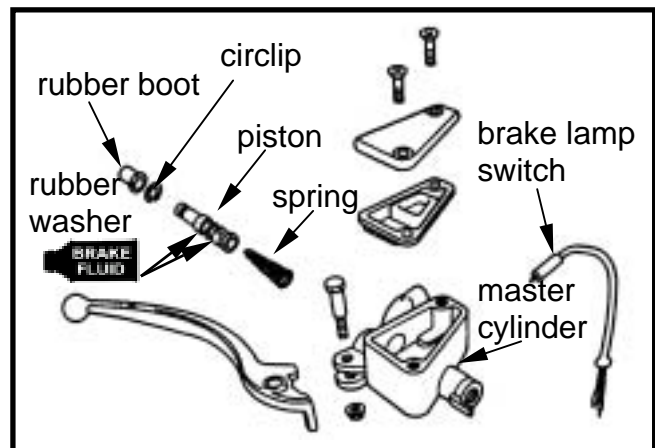

**INSTALLATION**

Place the master cylinder onto handlebar, and install the split ring and bolts. The "UP" mark on the split ring should face upward.

Align the split ring on the master cylinder seat with the alignment point on the handlebar.

Tighten the upper bolt of the seat to specified torque value, and then tighten lower bolt to the same specified torque value.

Install the brake lever, and connect leads to brake lamp switch.

Connect brake hoses with 2 new washes. Tighten the brake hose bolt to the specified torque value.

**Torque value: 3.5 kgf-m**

Make sure the hose is installed correctly.

**⚠ CAUTION**

Improper routing may damage leads, hoses or pipes.

**⚠ CAUTION**

Kink of brake leads, hose or pipe may reduce brake performance.

Add specified brake fluid and bleed the system and conduct the air-bleeding job for the system.

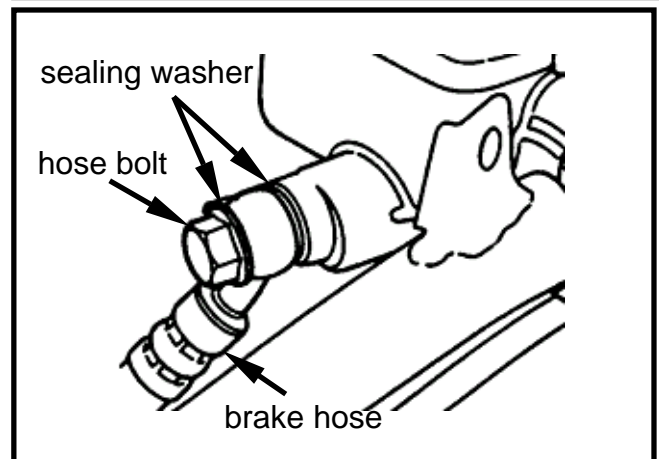
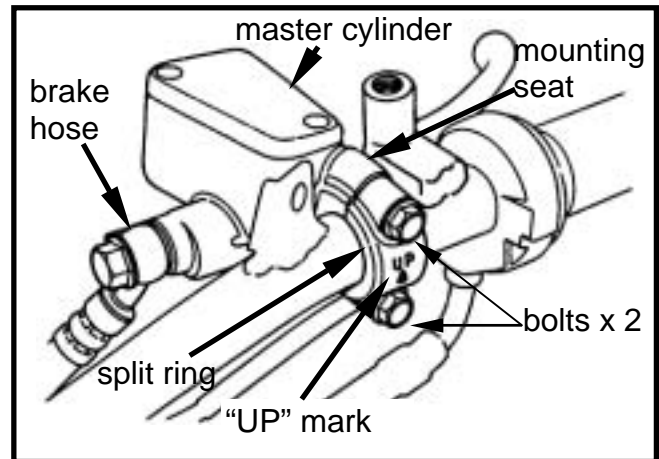

**DRUM BRAKE-DRUM**

**Brake Drum**

**Removal**

Use a vacuum cleaner and other suitable tools to clean the brake parts to minimize the hazard caused by the dust.

**⚠ Caution**

Inhaling dust may cause respiration system disorder even cancer. Never use an air hose or a dry brush as to clean the brake parts. Grease on brake lining will reduce braking efficiency.

Remove wheel. Remove brake drum from wheel hub.

**Inspection**

Check the brake drum for wear and damage, replace wheel hub if necessary. Measure the ID of hub at several points and record the largest value.

**Service limit : 131.0 mm**

**⚠ Caution**

Remove the rust by using #120 sand paper. An inside micrometer must be used when measuring ID of brake drum because the brake drum has a friction back plate.

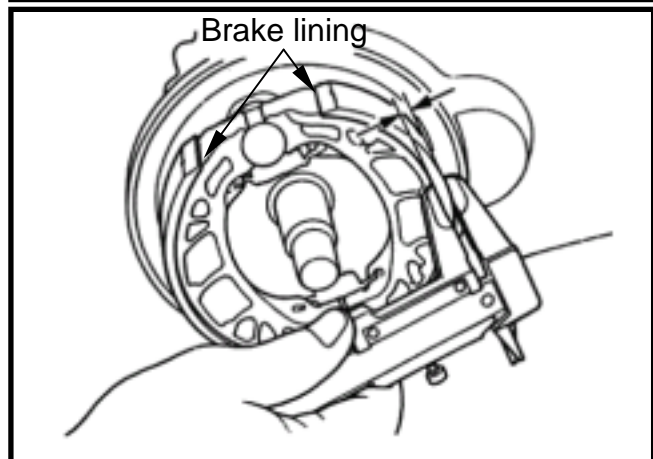
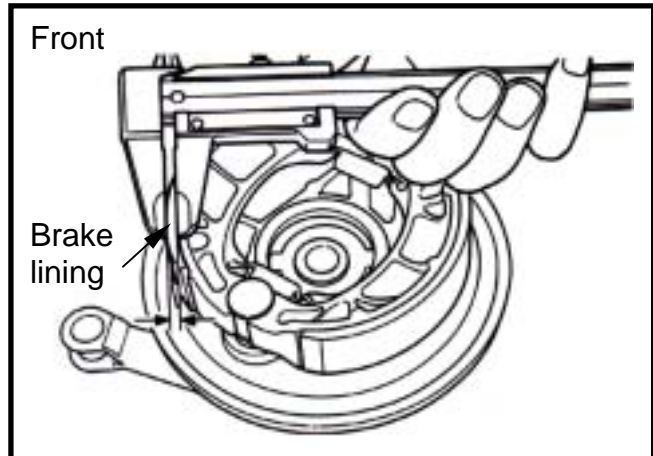
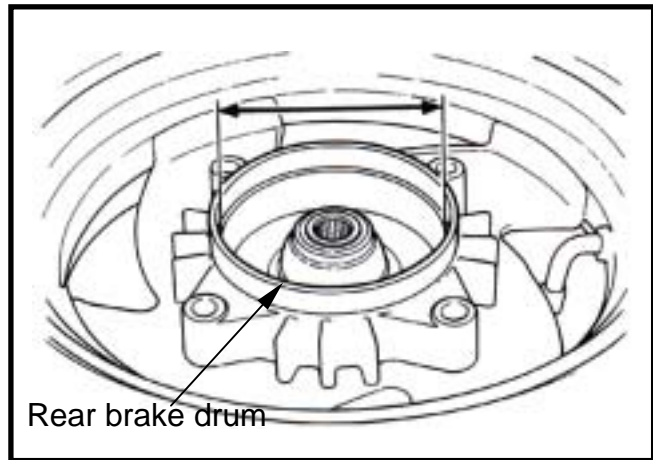
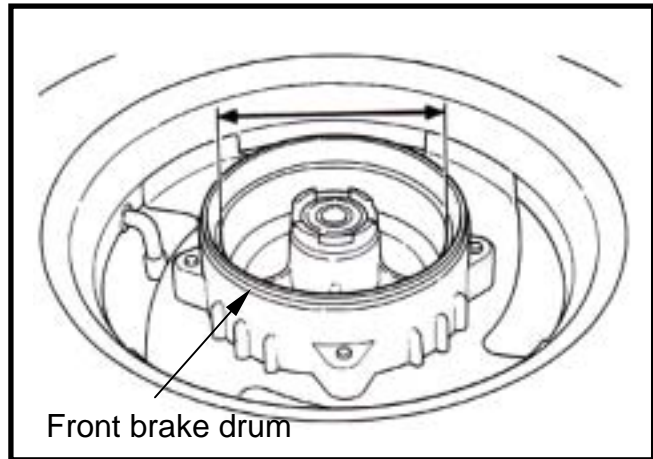

**BRAKE LINING**

**Inspection**

Measure the thickness of the brake lining at three points (both ends and center). If the thickness is less than specified, or if it is contaminated by oil or grease, replace as a set.

**Service limit : Front 2.0 mm**

**Rear 2.0mm**

**Removal**

 **Caution**

Brake linings must be replaced as a set.

Remove brake shoes from the brake panel by pulling out the brake linings with two hands.

**Installation**

Apply a thin coat of grease to the brake cam and the anchor pin.  
 Hook the brake spring onto the brake cam.  
 Pull out the brake linings and install them onto the brake panel. Wipe off the excessive grease from the brake cam and the anchor pin after installation.  
 Slightly grind the brake lining surfaces with sand-paper to clean the surfaces.

 **Caution**

Braking efficiency will be reduced if brake lining is contaminated by oil or grease.

**BRAKE PANEL**

**Removal**

Remove the brake arm bolt and then remove the brake arm, wear indicator, brake return spring and brake cam as well as the oil seal from the brake panel.

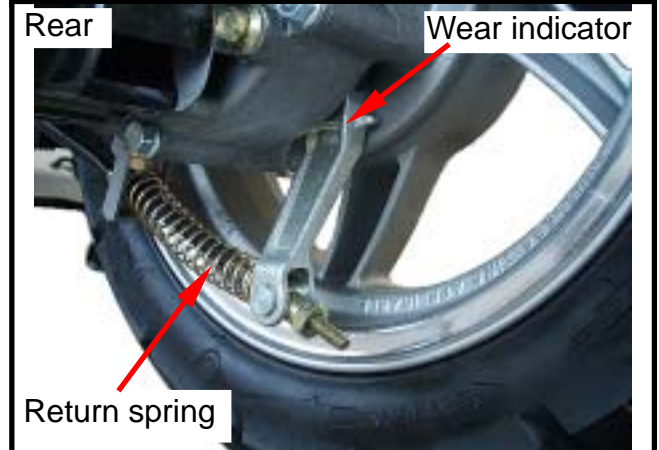
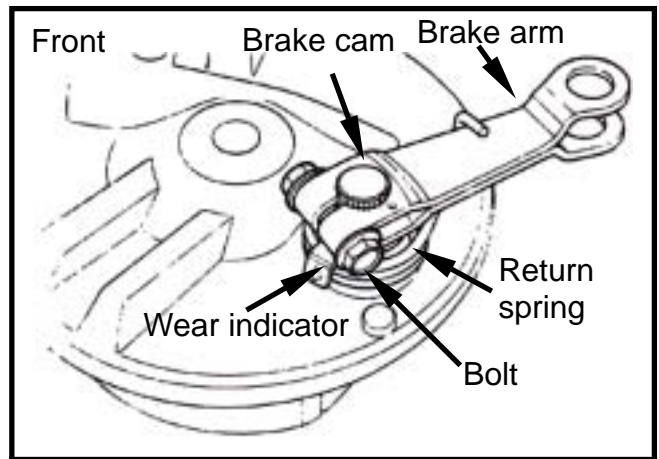
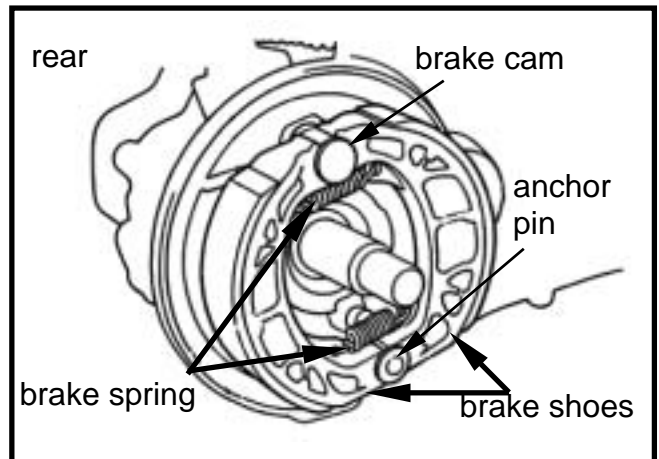
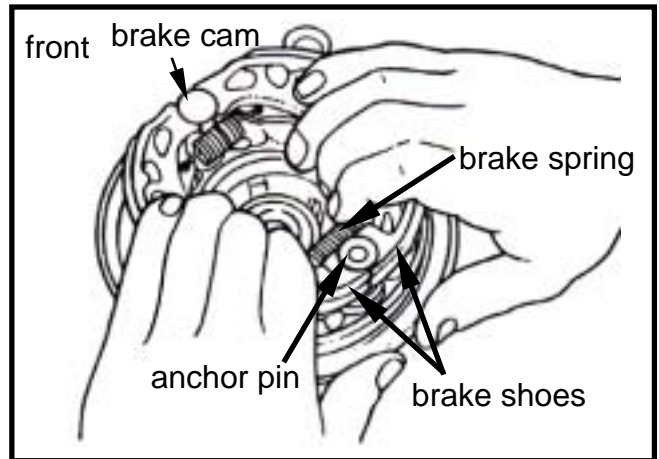



## Installation

### FRONT BRAKE PANEL

Apply a thin coat of grease onto the brake cam shaft.

Install the brake cam.

Apply a thin coat of grease onto the oil seal lip and then install the oil seal onto the brake cam shaft. Finally, install it on the brake panel.

Align the end-part of the brake return spring with the hole of brake panel.

Align both the inner gear of wear indicator and the mark on the brake arm with the indent gear of brake cam, and then install it. Tighten the bolts and nuts to specified torque.

**Torque: 0.8~1.2 kgf-m**

### REAR BRAKE PANEL

Apply a thin coat of grease between the oil seals on the brake cam shaft.

Install the brake cam.

Align the mark on the brake arm with the inner gear of the brake cam.

Tighten the bolts and nuts to specified torque.

Hook on the return spring.

**Torque: 0.8~1.2 kgf-m**

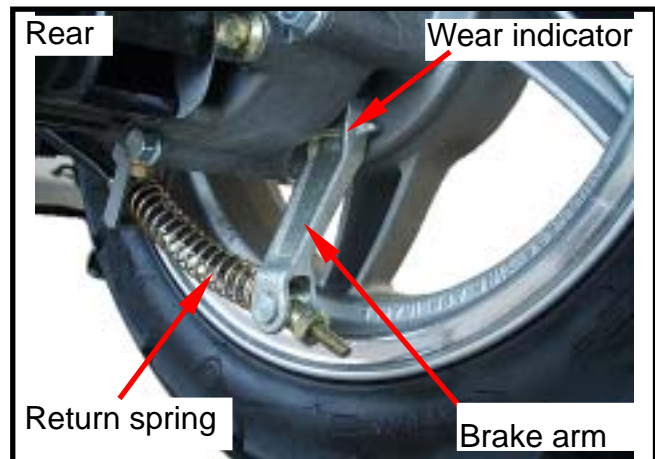
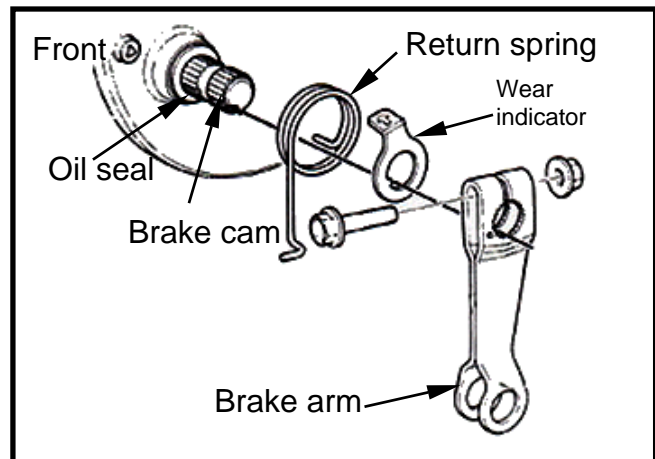

MECHANISM DIAGRAM .....	14-1	FRONT WHEEL .....	14-4
PRECAUTIONS IN OPERATION .....	14-2	FRONT SHOCK ABSORBER.....	14-9
TROUBLE DIAGNOSIS.....	14-2	FRONT FORK/STEERING COLUMN	14-9
STEERING HANDLE .....	14-3		

**MECHANISM DIAGRAM**

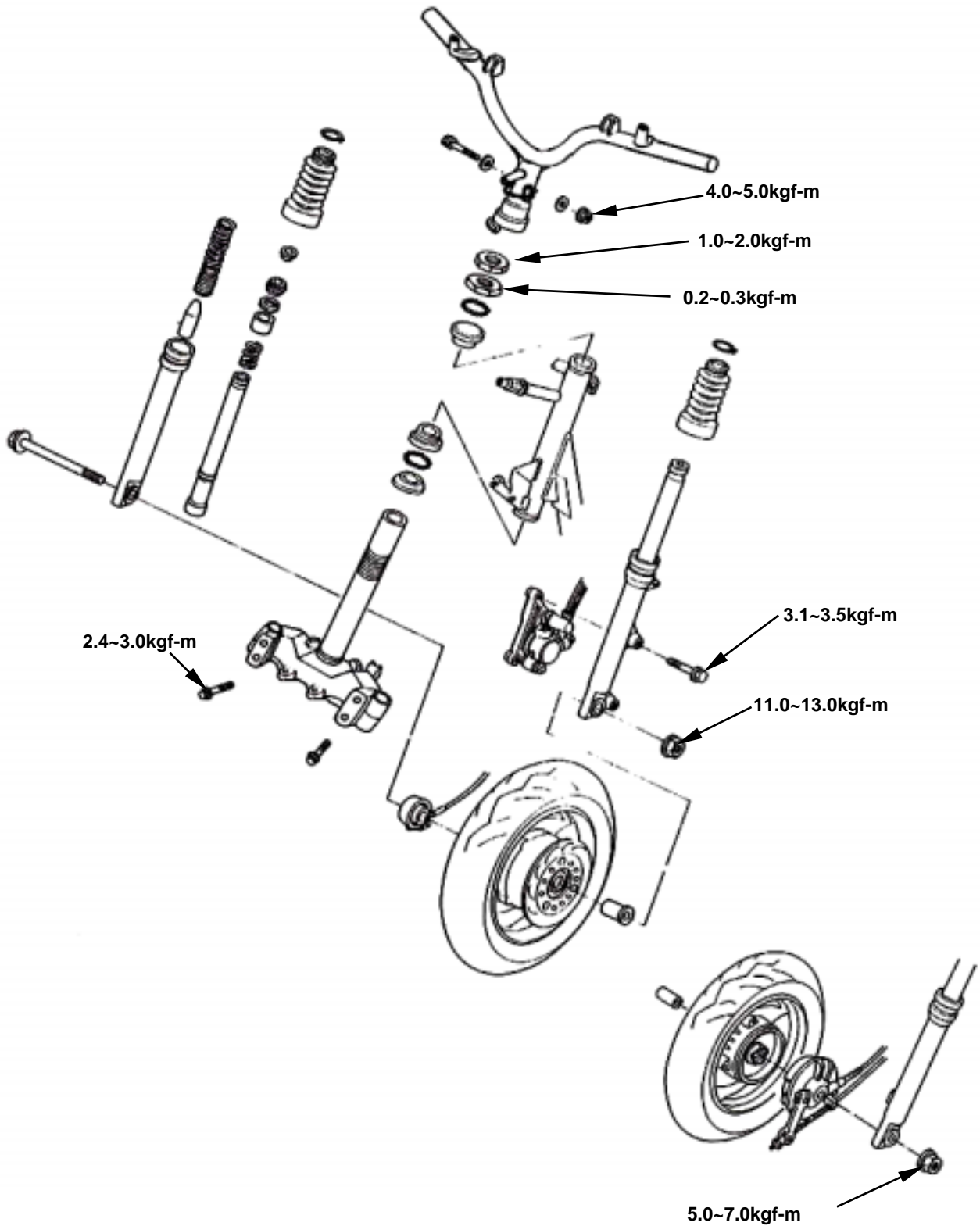

**PRECAUTIONS IN OPERATION****General Information**

- Before remove front wheel, use a jack to lift the body until front wheel free of ground, and take care not to rotate body in reverse.
- Be careful not to allow oil or grease get on brake drum or linings.

**Torque values**

Front wheel axle	5.0~7.0kgf-m
Steering handlebar nut	4.0~5.0kgf-m
Steering column top cone sliding ring	0.2~0.3kgf-m
Steering column lock nut	1.0~2.0kgf-m
Speedometer cable nut	0.15~0.3kgf-m
Front shock absorber: Upper nut	2.4~3.0kgf-m

**Tools****Special service tools**

- Steering column wrench
- Bearing remover
- Inner type bearing remover
- Attachment, 32x35 mm
- Attachment, 42x47 mm
- Steering column nut wrench
- Steering column top cone ring nut wrench

**TROUBLE DIAGNOSIS****Hard steering stem**

- Over tightening of steering stem lock nut
- Broken steering stem steel ball and cone bearing seat
- Insufficient tire pressure

**Steering stem off center**

- Uneven left/right cushion
- Bend fork
- Bent front wheel/tire offset

**Front wheel wobbling**

- Deformed rim
- Front wheel bearing loose
- Faulty tire
- Wheel axle nut tightened improperly

**Soft front suspension**

- Weak fork springs
- Oil leakage of the shock absorber seal

**Front suspension noise**

- Cushion cover friction noise
- Cushion bolts loose

**STEERING HANDLE****REMOVAL**

Remove handle front & rear covers and the front cover (refer to chapter 12).

**Drum Brake**

Remove the brake lever bolt & nut and then remove the front brake cable.

Remove acceleration handlebar screw and then remove the handlebar, acceleration cable, and handlebar cover & seat.

Remove the speedometer cable from the speedometer gear on the gear box.

**Disc Brake**

Remove the 2 bolts of the brake master cylinder, and then take out the master cylinder and the split ring.

 **Caution**

Do not operate the front brake lever to avoid to pressing out the brake lining when removing the master cylinder.

Remove acceleration handlebar screw and then remove the handlebar, acceleration cable, and handlebar cover & seat.

Remove the rear brake lever nut and screw, then take out the rear brake cable.

Remove the brake lever seat bolt, and then remove the seat.

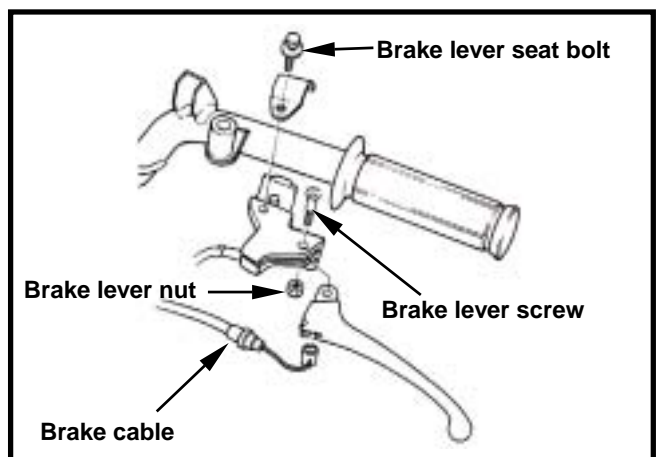
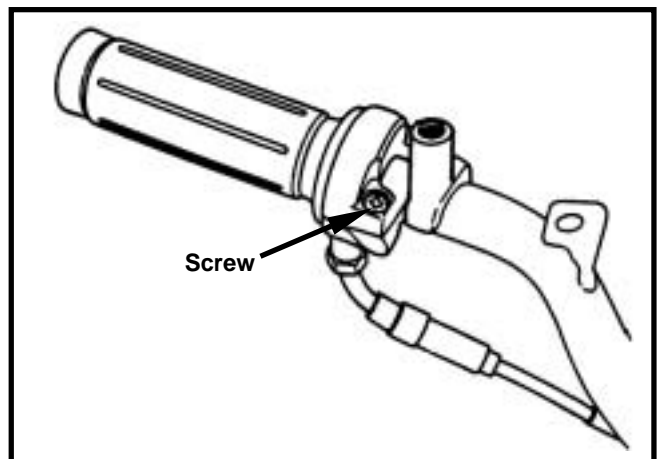
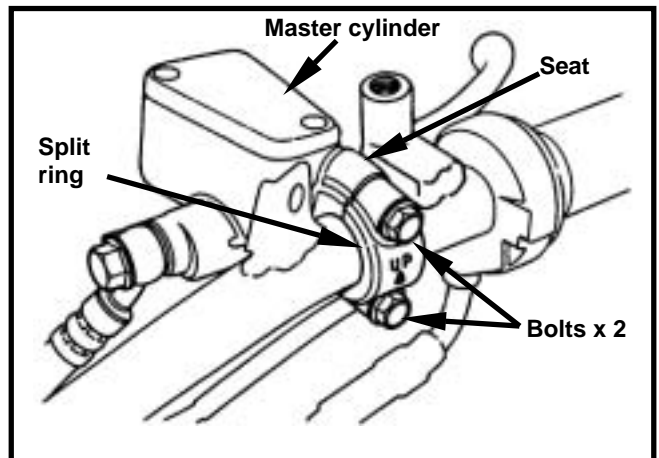
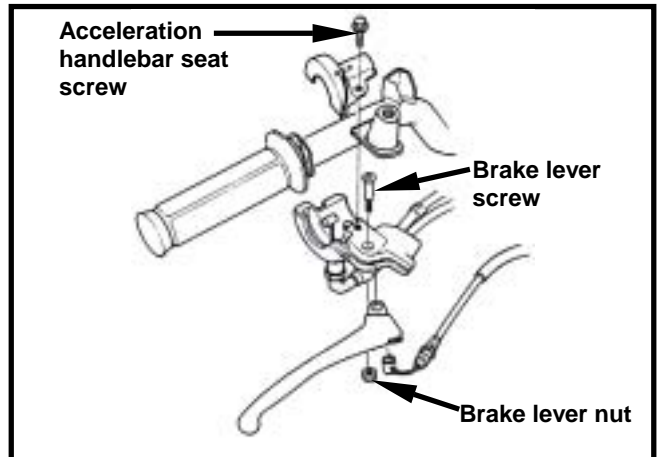

With a wrench to hold the handlebar bolt and then remove the nut.  
 Take out the handlebar after removed the bolt.

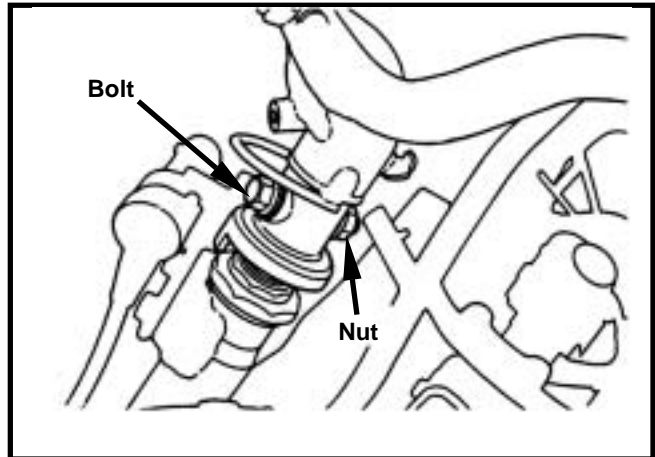

**Installation**

Install the handlebar according to the reverse procedure of removal.  
 Apply with some grease onto the handlebar moving parts when installing the acceleration handlebar seat, acceleration handlebar, and acceleration cable.

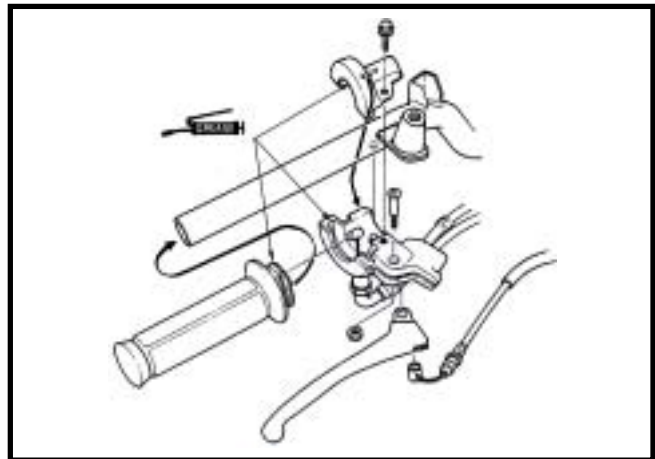

**FRONT WHEEL**

**Removal**

**Disc Brake type**

Support body bottom and lift front wheel free of ground.  
 Remove the bolts, and disconnect speedometer cable from the gear box.

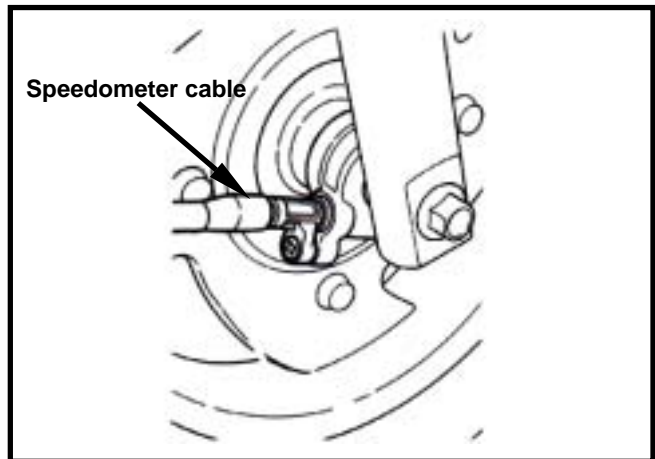

Remove the wheel axle nut and pull out the axle. Then, remove the front wheel.

**⚠ Caution**

Do not operate the front brake lever to avoid to pressing out the brake lining when removing the master cylinder.

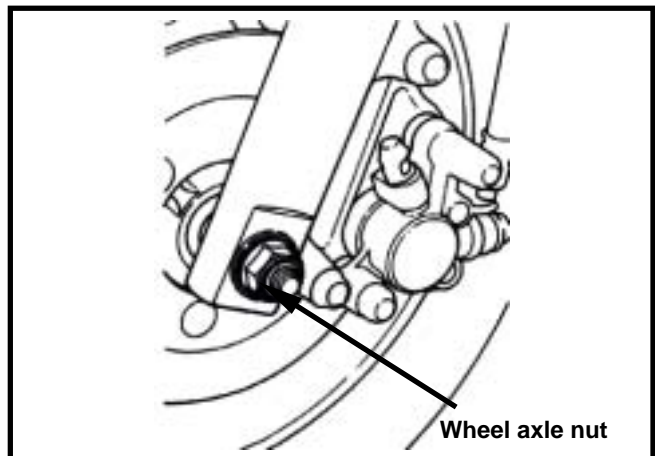

**Drum brake type**

Support body bottom and lift front wheel free of ground.

Remove the bolts, and disconnect speedometer cable.

Remove the wheel axle nut and pull out the axle. Then, remove the front brake panel and the front wheel.

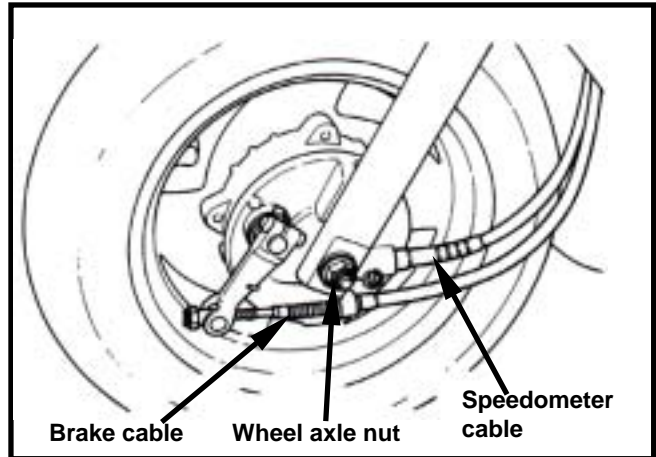
**Inspection****Wheel axle**

Set the axle in V-blocks and measure the run-out.

**Service limit: 0.2 mm.**

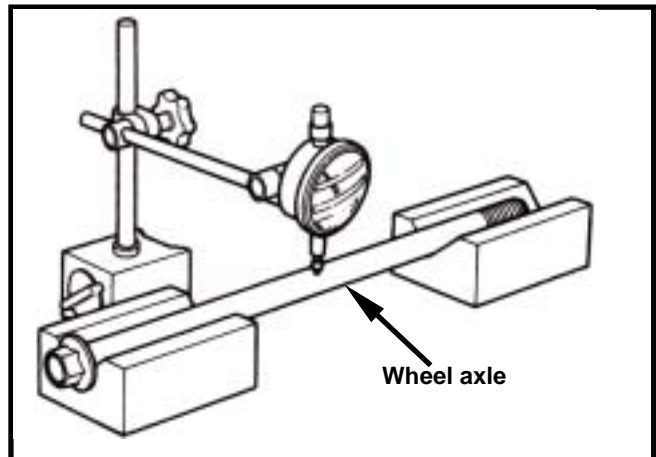
**Wheel Rim**

Place the wheel onto a rotated bracket.

Turn the wheel with hand and measure its wobble value with a dial gauge.

**Service limit:**

**Radial : 2.0 mm**

**Axial : 2.0 mm**

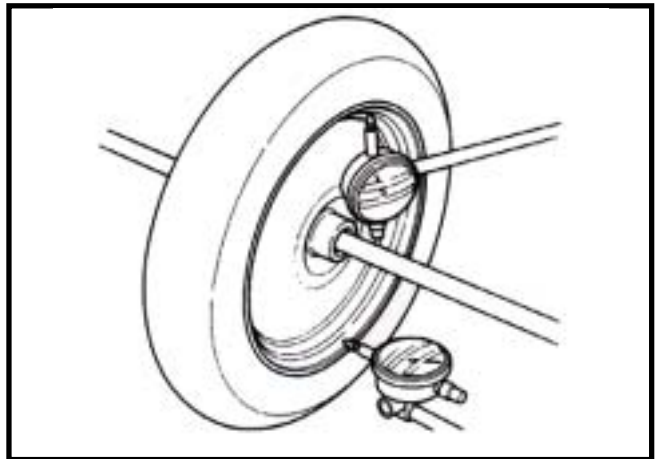
**Disassembly (Disc type)**

Remove 3 hex socket bolts and brake disc.

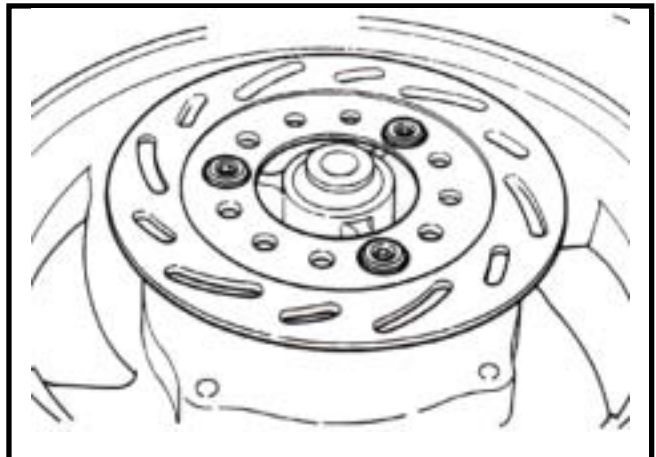

Remove the left axle ring and dust seal.  
 Remove the dust seal on the right side of speedometer gear.  
 Remove the bearing with the inner type bearing remover.  
 Take out the bearing spacer and then remove the other bearing.

**Tool:**

Inner type bearing remover

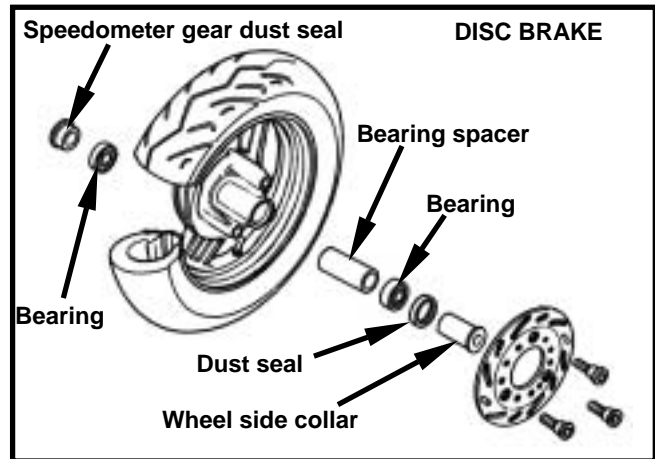

**Disassembly (Drum Brake)**

Remove the right dust seal.  
 Remove the bearing with the inner type bearing remover.  
 Take out the bearing spacer and then remove the other bearing.

**Tool:**

Inner type bearing remover

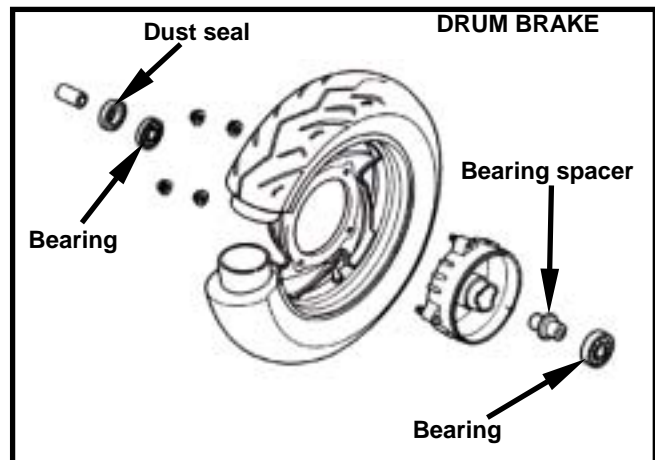

**Bearing Inspection**

Turn the inner race of bearing with fingers. The bearing should be turn smoothly. Also check if the outer collar is tightly connected to the wheel hub.  
 If the bearing do not turn smoothly, or if they are too loose in the races, or damaged, then, remove and replace the bearings with new ones.

**⚠ Caution**

The bearing must be replaced in pair.

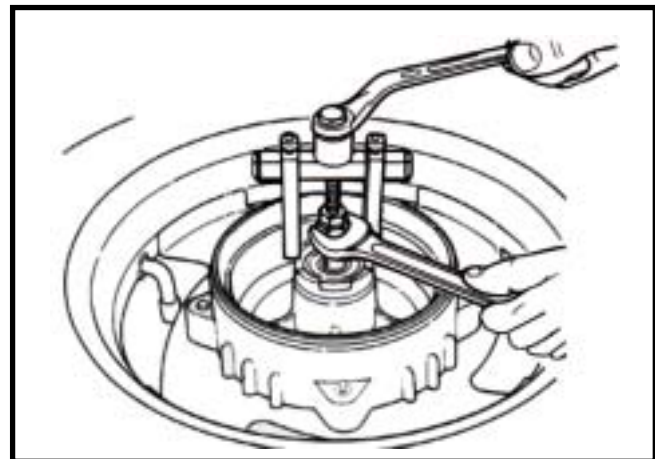

**Installation**

Install the bearing according to the reverse procedure of removal.  
 Apply some grease into the bearing seat of the wheel hub.  
 Install the left bearing onto the seat.  
 Install the bearing spacer and then install the right bearing onto the seat.

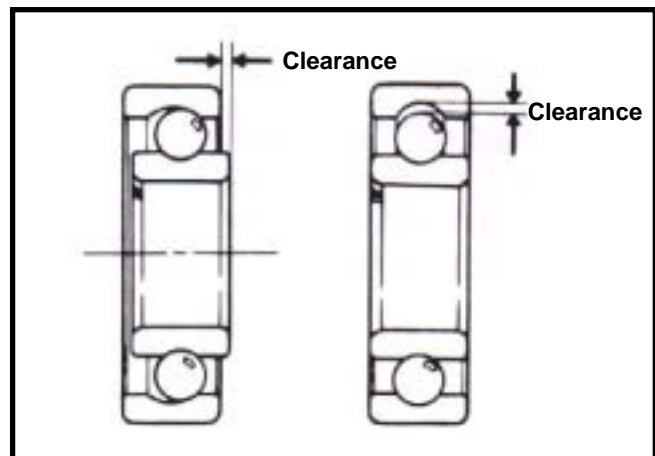

### ⚠ Caution

- Do not install used bearing and replace the bearing once it has been removed.
- Do not the bearing in tile motion when installing.

### Tool:

C-type compressor or bearing compressor.

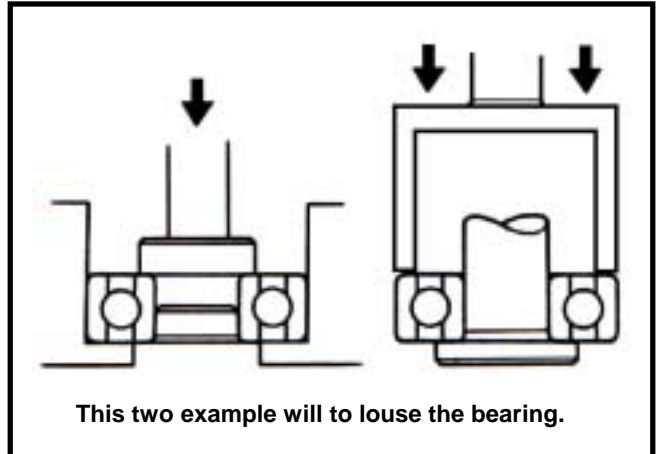

### Disc Brake

Apply with some grease inside of the dust bearing.

Install the dust seal and the front wheel side collar.

Apply with some grease on both side of the speedometer gear oil seal, and then install the seal.

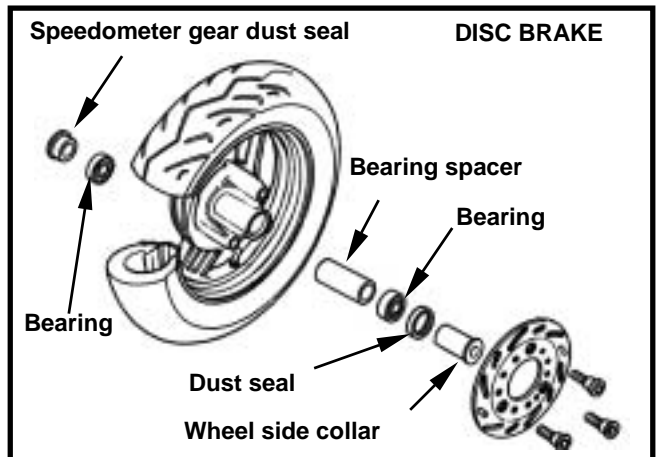

### Drum Brake

Apply with some grease inside of the dust seal, and then install the seal and the front wheel side collar.

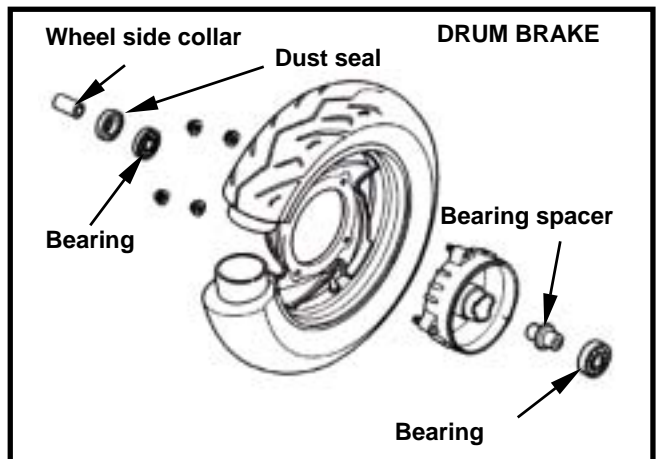

### Installation

#### Drum Brake

Apply with some grease on the speedometer driving gear, and then install washer & driving gear into the brake panel.

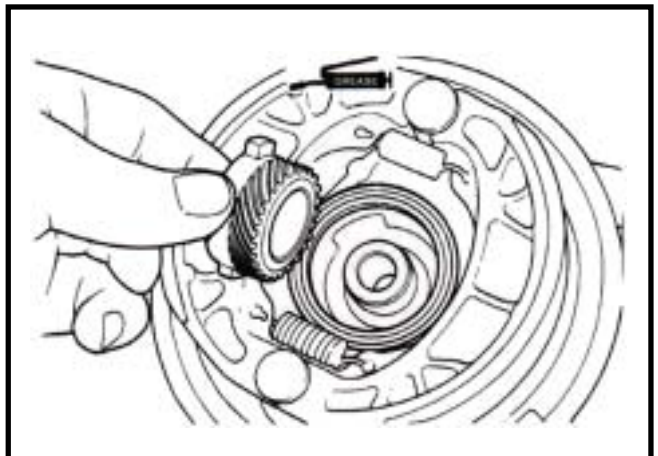



Align the flange part on the speedometer gear with the slot of wheel hub, and then install the brake disc (drum brake) or speedometer gear box.

**⚠ Caution**

Contaminated brake lining will reduce brake performance so the brake lining, brake drum and disc must be free of grease.

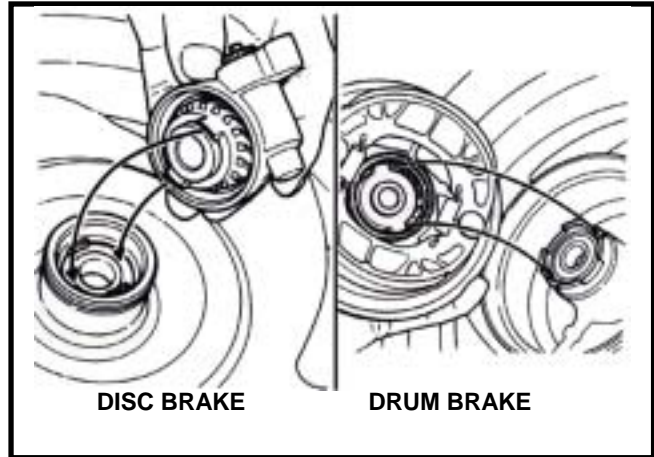

Place the front wheel between the front shock absorbers.

**Drum Brake**

Align the brake panel slot with the stopper of the shock absorber.

**Disc Brake**

Align the flange part on the speedometer gear with the slot of shock absorber stopper.

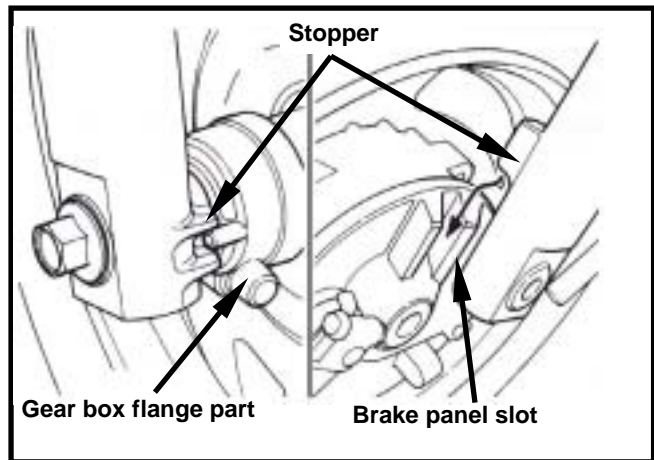

**Disc Brake**

Install the front wheel axle from right shock absorber side.

Install the wheel axle nut, and tighten it to specified torque value.

**Torque value: 11.0~13.0kgf-m**

Connect the speedometer cable to the speedometer gear box.

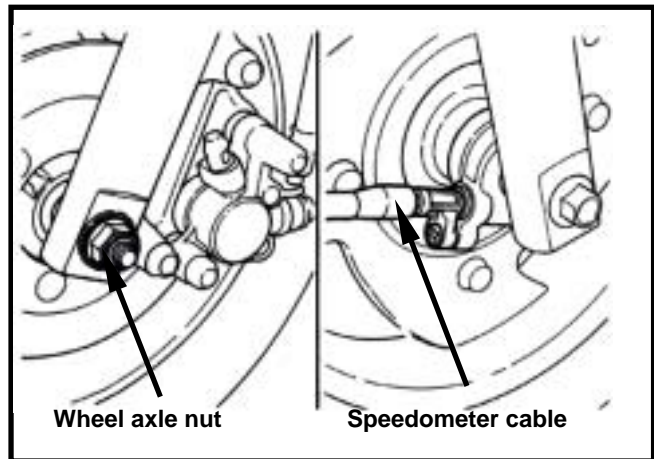

**Drum Brake**

Install the front wheel axle from right shock absorber side.

Install the wheel axle nut, and tighten it to specified torque value.

**Torque value: 5.0~7.0kgf-m**

Connect the speedometer cable and brake cable to the brake panel.

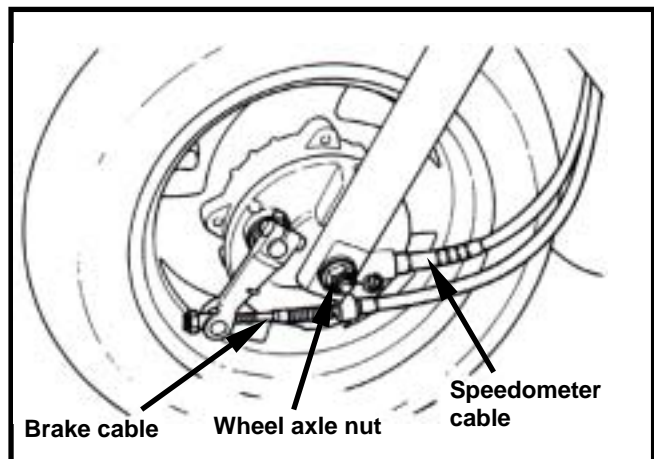

**FRONT SHOCK ABSORBER****Removal**

Remove the front fender, front lower spoiler, front guard, and front wheel as well as front brake components.

Remove the brake fluid hose clipper or cable guide on the left shock absorber. (bolt x 1)

As for disc brake, remove the cable guide on the right shock absorber. (bolt x 1)

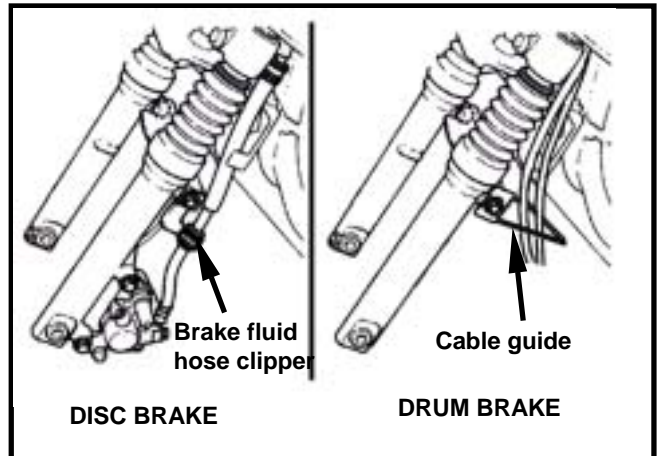

Remove the top connection bolt of the right shock absorber. (bolt x 4)

Remove the shock absorber from the front fork.

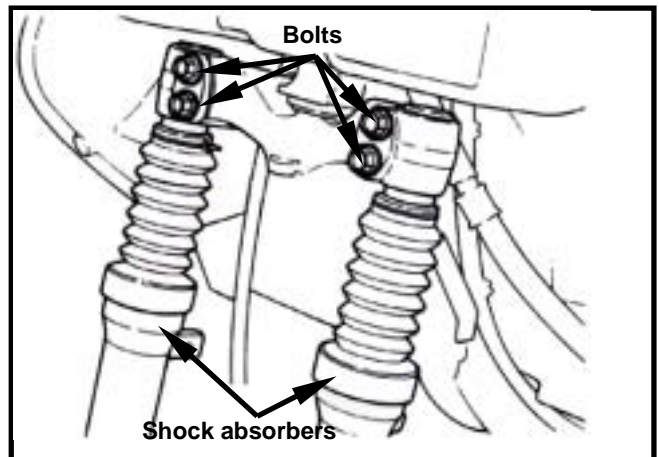
**Installation**

Install the shock absorbers according to the reverse procedure of removal.

Align the shock absorber top-edge with the top-end level of the front fork when installing the front shock absorber onto the front fork. Then, tighten the nut.

**Torque value: 2.4~3.0kgf-m**

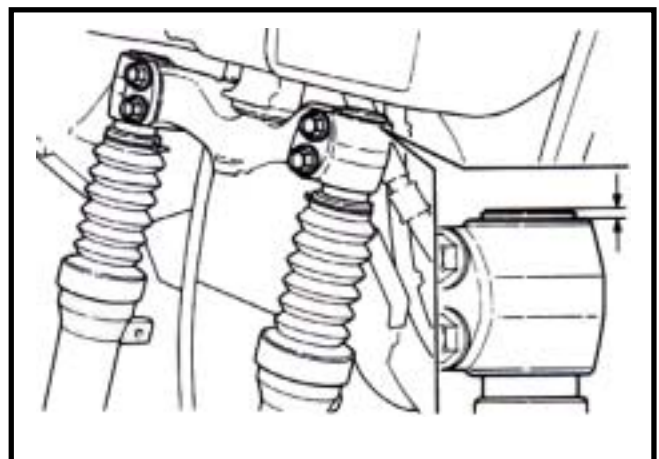
**FRONT FORK/STEERING COLUMN****Removal**

Firstly, remove the handlebar, front wheel, front brake set, and front shock absorbers. Remove the steering column nut.

Remove the top cone ring, and then remove the steering column.

**⚠ Caution**

Place the steering column bearing balls into a parts container to avoid missing or shortage.

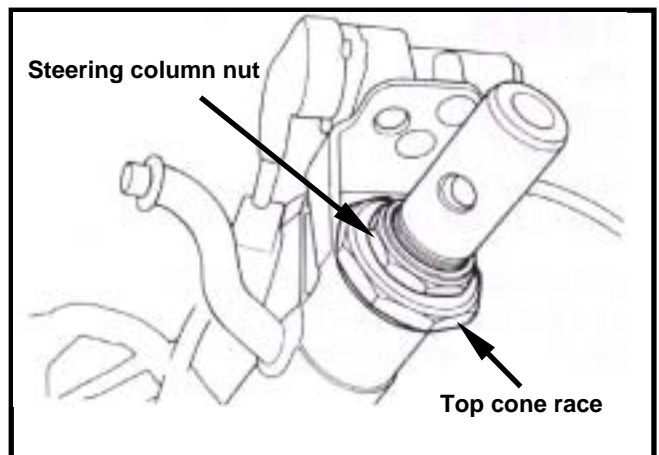

With a plastic hammer to tap the steering column slightly, and then remove the top ball bearing seat.

Remove the lower-end cone bearing seat on the frame with a punch.

**⚠ Caution**

Do not damage the frame and the steering column.

**Installation**

Install a new top-cone bearing seat onto the top of steering column.

And then, push the lower-cone bearing seat from bottom until to locking position.

**⚠ Caution**

Do not let the ball bearing in title motion as installation.

Apply with some grease onto the top & bottom bearing balls, and then install the balls into bearing seat. Press in a new lower cone-race onto the steering column, and lubricate it with grease. Install the steering column.

Lubricate the top-cone race with grease. Drive the cone-race into the steering column until contact with the top bearing seat no clearance. Note, return 1/2 turn and then tighten the top cone race to specified torque. (tighten the race around 1/4~3/8 turn more.)

**Torque value: 0.2~0.3kgf-m**

**⚠ Caution**

Do not tighten the top cone race too tight to prevent from damage the ball bearing seat when tightening the top cone race.

Install the steering column nut and lock the top cone race. Then, tighten the nut.

**Torque value: 1.0~2.0kgf-m**

Install the bearing seat according to the reverse procedure of removal.

**⚠ Caution**

Check the steering column if it can be turned freely and no clearance in vertical motion.

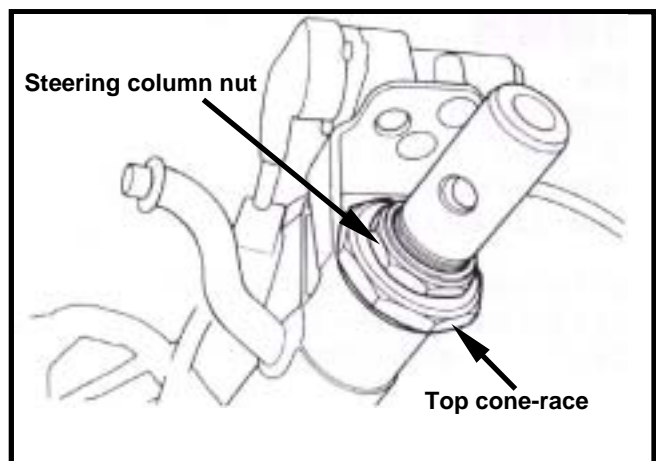
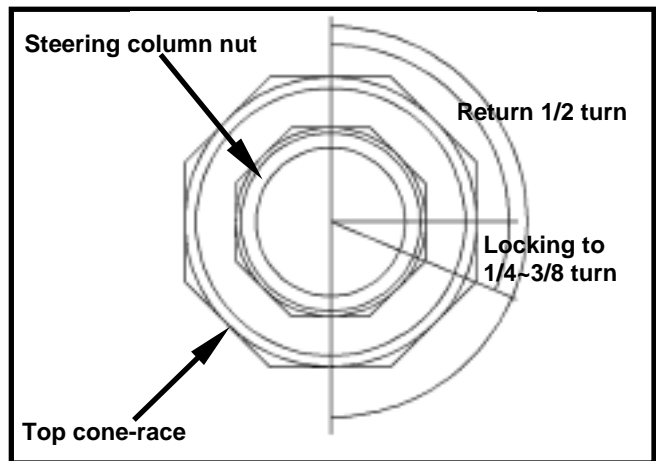
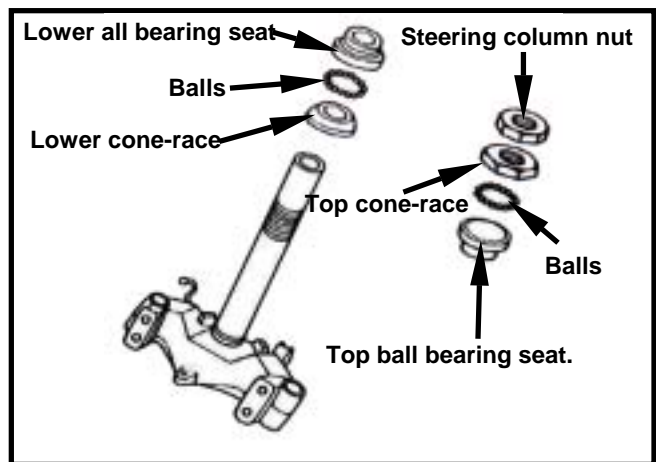
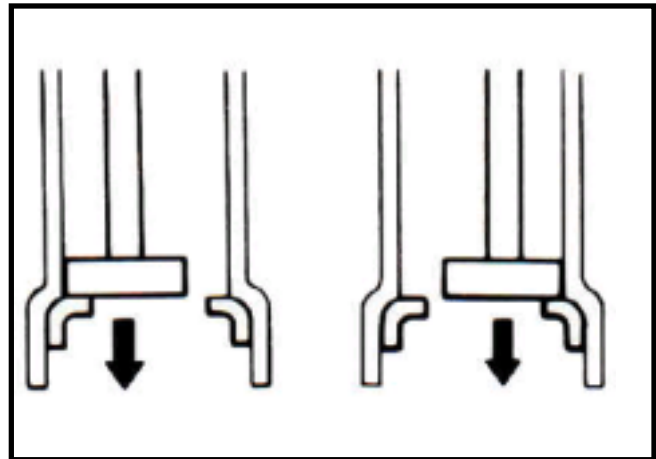

MECHANISM DIAGRAM.....	15-1	EXHAUST MUFFLER.....	15-3
PRECAUTIONS IN OPERATION.....	15-2	REAR WHEEL.....	15-3
TROUBLE DIAGNOSIS .....	15-2	REAR SHOCK ABSORBER.....	15-4

**MECHANISM DIAGRAM**

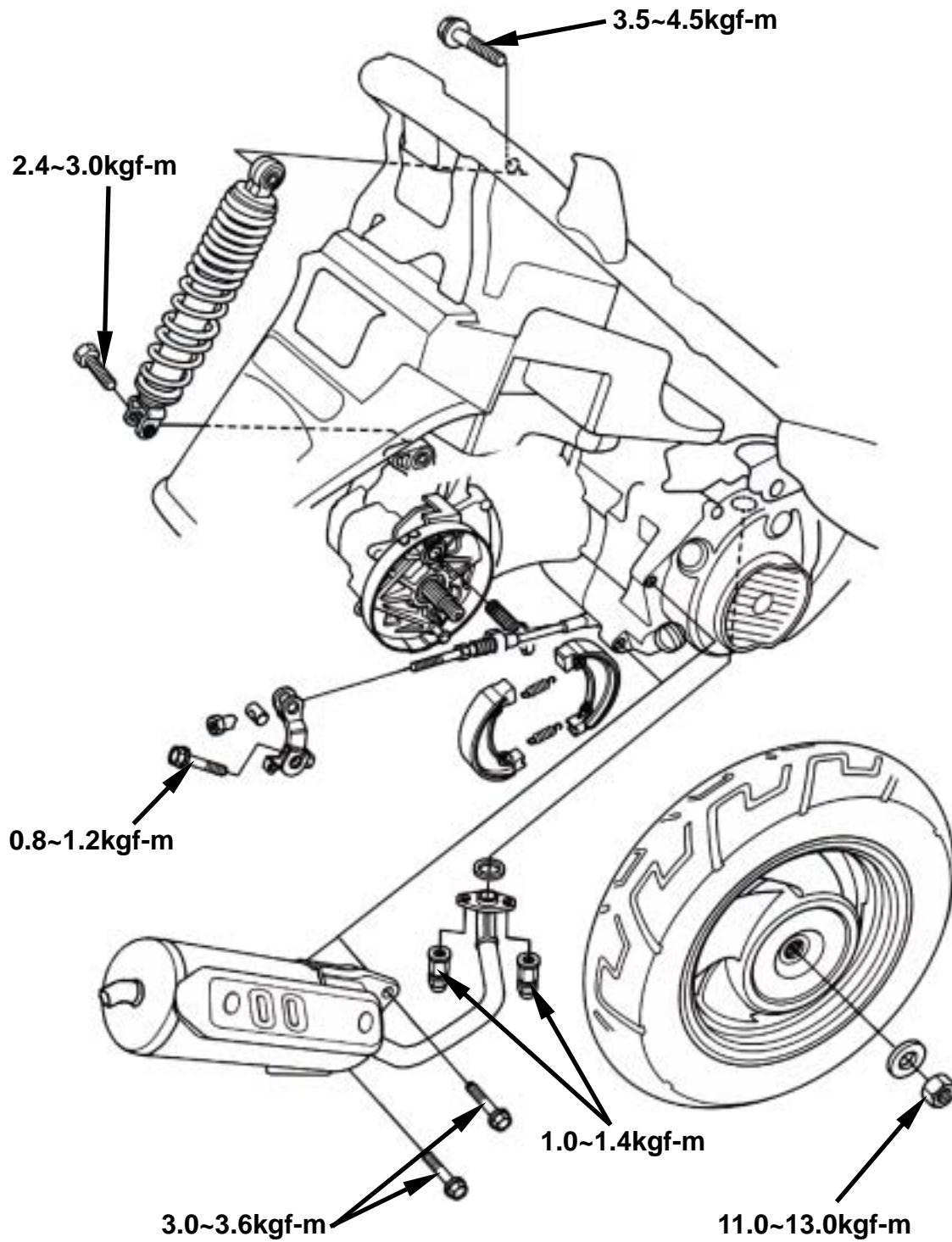

## PRECAUTIONS IN OPERATION

### General Information

As for the wheel removal, service, and installation procedures, please refer to the service manual of high speed tire.

### Specification

Unit: mm

Items		Standard	Limit
Wheel wobbling	Radial	-	2.0
	Axial	-	2.0
Thickness of rear brake lining		4.0	2.0

### Torque values:

Rear axle nut	11.0~13.0kgf-m
Rear shock absorber upper mount bolt	3.5~4.5kgf-m
Rear shock absorber lower mount bolt	2.4~3.0kgf-m
Exhaust muffler connection nut	1.0~1.4kgf-m
Exhaust muffler connection bolt	3.0~3.6kgf-m

## TROUBLE DIAGNOSIS

### Rear wheel wobbling

- bend wheel rim
- poor tire
- loosen wheel shaft

### Shock absorber too soft

- insufficient shock absorber spring force

### Braking Noise

- worn brake lining
- brake drum deformation
- improperly brake panel installation
- unparalleled brake drum or wheel unparallel.

### Poor brake performance

- Poor brake adjustment
- contaminated brake lining
- worn brake lining
- greased brake drum
- contaminated and seized brake cable
- improperly installation of brake cable

**EXHAUST MUFFLER****Removal**

Remove the front-end nut of the exhaust muffler. (nuts x 2)  
 Remove the bolts. (bolts x 2)  
 Remove the exhaust muffler.

**Installation**

Install the exhaust muffler according to the reverse procedure of removal.

**⚠ Caution**

Replace the exhaust muffler gasket if it is broken or deformed.

**Torque value:**

Exhaust muffler connection bolt:  
 3.0~3.6kgf-m  
 Exhaust muffler connection nut:  
 1.0~1.4kgf-m

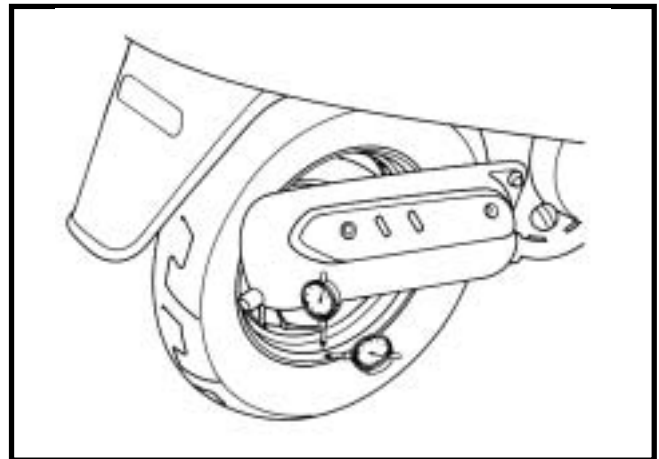
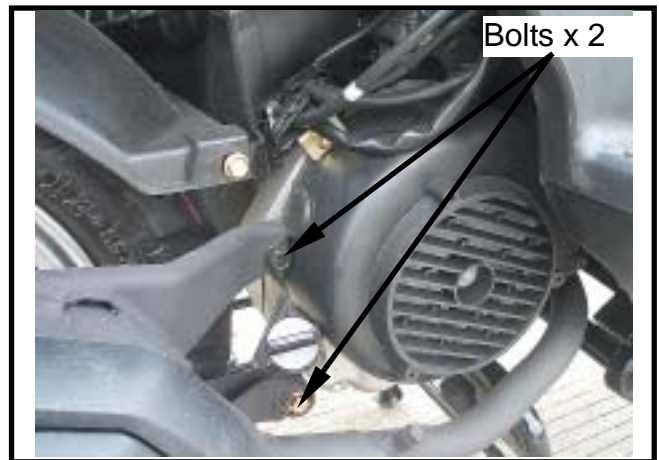
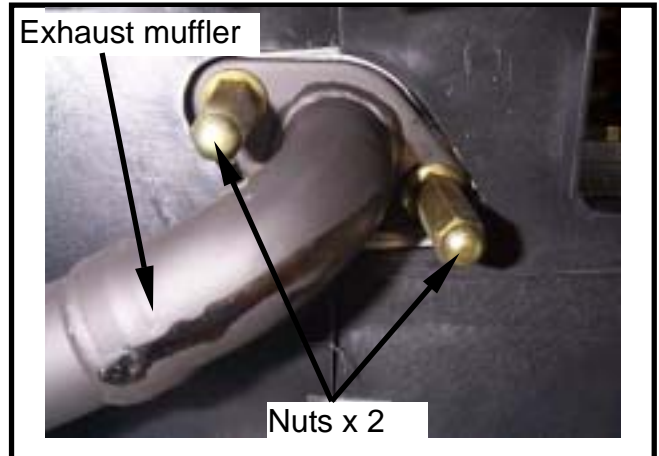
**REAR WHEEL****Inspection**

Measure wheel rim wobbling.

**Service limit:**

**Radial: 2.0mm**

**Axial: 2.0mm**

If the wheel rim wobbling out of the specification, except resulted from the wheel rim deformation, it might be loosen or worn final driving shaft bearing or bend, deformed driving shaft.

**Removal**

Remove the right cover.(screws x 4)  
 Remove the battery. (bolts x 2)  
 Remove the battery cover assembly. (bolts x2, nuts x 2)  
 Remove the rear wheel. (wheel axle nut x1)



## REAR SHOCK ABSORBER

### Removal

- Remove the left & right covers. (screws x 8)
- Remove the luggage box. (bolts x 4, nuts x 2, screw x 1)
- Remove the rear carrier. (bolts x 3)
- Remove the body cover (bolts x2)
- Remove the air cleaner bolts (bolts x2)
- Remove the lower nut of the rear shock absorber (bolt x 1)
- Remove the upper nut of the rear shock absorber (bolt x 1)
- Remove the rear shock absorber.

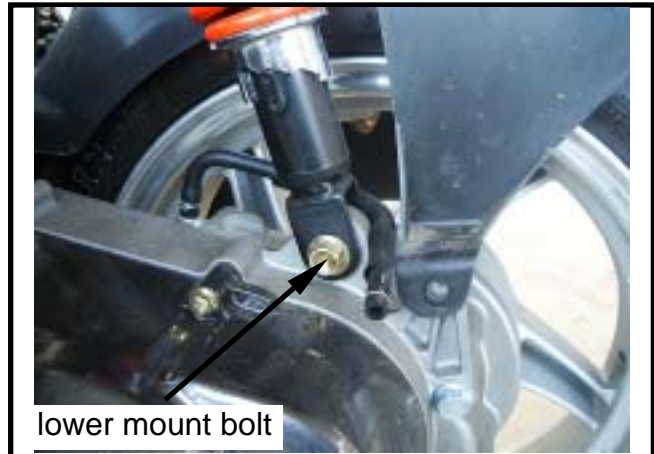

### Installation

Install the rear shock absorber according to the reverse procedure of removal.

### Caution

The rear shock absorber has to be replaced with one set and can not be replaced by unauthorized persons. Otherwise, it might damage the rubber bushing and construction.



### Torque values

- Rear shock absorber lower mount bolt:  
2.4~3.0 kgf-m
- Rear shock absorber upper mount bolt:  
3.5~4.5 kgf-m

MECHANISM DIAGRAM .....	16-1	STARTING SYSTEM .....	16-14
PRECAUTIONS IN OPERATION .....	16-2	METER .....	16-15
SPECIFICATION .....	16-3	LIGHTS/BULBS .....	16-17
TROUBLE DIAGNOSIS .....	16-4	MAIN SWITCH/HORN .....	16-19
CHARGING SYSTEM .....	16-5	FUEL UNIT .....	16-22
IGNITION SYSTEM .....	16-11		

**MECHANISM DIAGRAM**

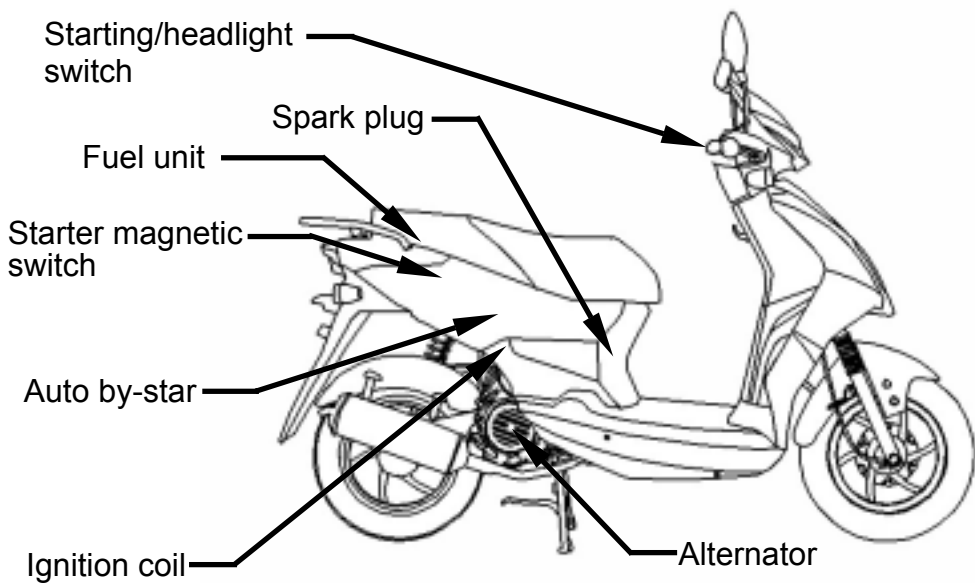
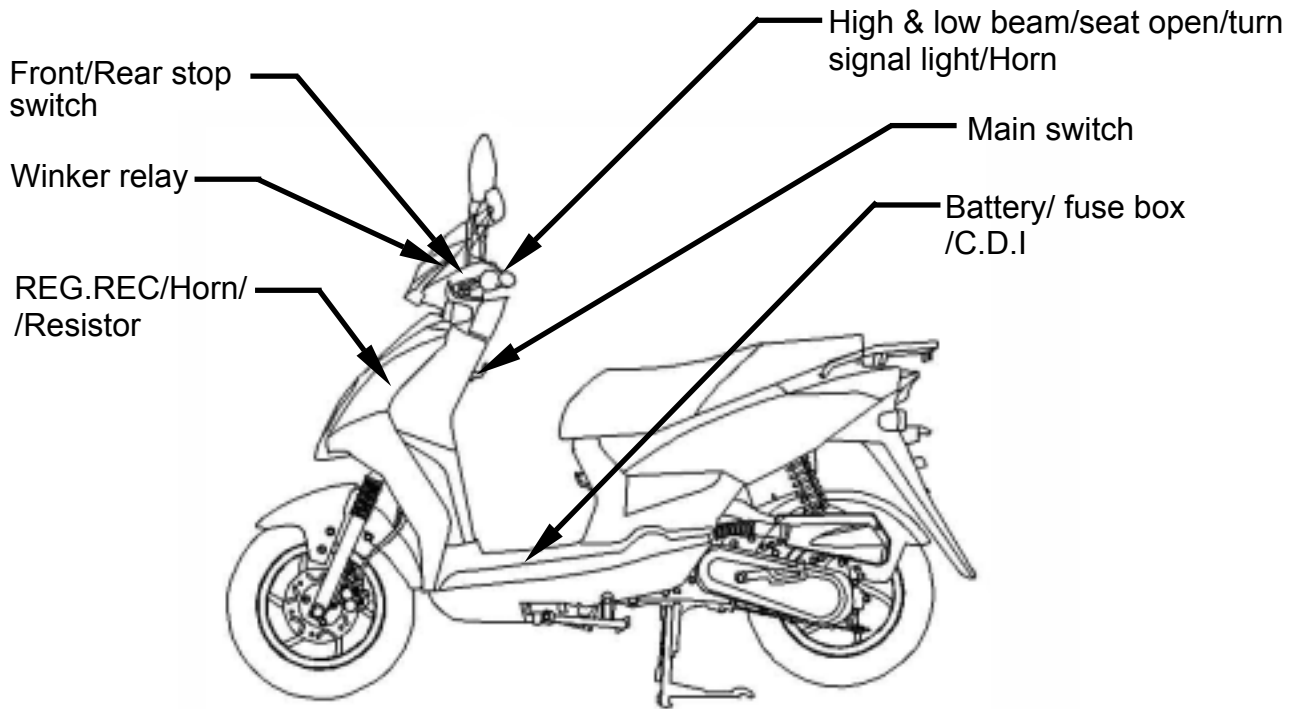



**PRECAUTIONS IN OPERATION****Charging System**

- When remove the battery, the disconnection sequence of cable terminals shall be strictly observed. (First disconnect the negative cable terminal, next, the positive cable terminal.)
- MF (Maintenance Free) battery does not need to check, add electrolyte or distilled water.
- Battery must be taken out from scooter when charging the battery. But do not open the battery caps.
- Do not quick charge the battery unless in emergency.
- A voltmeter must be used when checking battery charging condition.
- Battery can be charged or discharged alternately. To set a discharged battery idle for a prolonged period will shorten its service life and reduce its capacity. Usually, battery's capacity will reduce after 1~2 years. After low capacity battery was charged, its voltage will increase. If it connects to an additional load, the voltage will reduce suddenly, and then go up again.
- Over-charged battery. Usually, the over-charged battery can be seen externally. If a short circuit occurred inside the battery, there will be no voltage on the terminals of battery if voltage regulator does not operate. Then, the battery's voltage will be too high that may reduce battery's life.
- The battery will be self-discharged if it was set idle for a long time. An idle battery must be charged about every 2months.
- A new battery filled with electrolyte will generate a voltage after filled out electrolyte. The voltage should be in 12.5V or more after 10 minutes. When electrolyte is not enough, the battery must be filled with electrolyte and then charged to prolong the battery's life-span.
- Please check electrical device according to the procedure of diagnosis chart.
- Do not disconnect and connect the connector of electrical devices when current is passing these devices because this will generate high voltage and the electrical components in the voltage-current regulator will be damaged. The ignition switch must be turned OFF before performing any work.
- Please do not replace with traditional type battery as replacement.
- Please refer to the removal instruction when removing the alternator and the pulse generator.

**Ignition System**

- Please follow the procedure of trouble diagnosis chart to check ignition system.
- The ignition system equipped with a auto-advanced timing device in CDI unit. Thus, ignition timing need not to be adjusted. In case of incorrect ignition timing occurred, check the CDI unit or alternator system. It has to check the ignition timing with the ignition timing light if replaced these components.
- Do not hang or impact the CDI unit of ignition system because the major faulty of CDI unit is caused by impact. Therefore, take care when disassembling.
- Most of ignition system problems were resulted from poor connecting connector. Please check the connectors first when servicing.
- Make sure that the heat range of spark plug is suitable. Improper spark plug is the main cause of poor engine operation or combustion.
- Inspection procedures in this manual are based on Max. voltage. This manual also contains methods of how to check ignition coil resistance and component operation.
- Please follow the continuity chart to check ignition switch.

**Starting System**

- Starting motor can be removed directly from engine.
- Please refer to chapter 10 for starting clutch removal procedures.

### Specification Charging System

Items		Specification	
Battery	Capacity/type	12V 7Ah	
	Charging rate	STD:0.6A/5~10hrs, emergency charging: 6A/0.5hrs	
	Voltage (20 )	Full charged	13.1V
		Under charged	12.3V
Alternator	Capacity	12V / 6.2A	
	Lighting coil resistance (20 )	Between yellow-green: 0.8±0.1	
	Charging coil resistance (20 )	Between white-green: 0.6±0.1	
Leaking current		Less 1mA	
RPM for starting charging		2000rpm(headlight ON)	
Voltage controlled by regulator		14.0±0.5 V	
Resistor	Resistance (20 ) 5W5	4.5~5.5Ω	
	Resistance (20 ) 30W7.5	7.0~8.0Ω	

### Ignition System

Item		Specification
Spark plug	Standard	NGK CR7HSA (Recommended usage)
	Hot type	NGK CR8HSA
	Cold type	NGK CR6HSA
	Spark plug gap	0.6~0.7 mm
Ignition coil resistance (20 )	Primary	0.21±10%Ω
	Secondary	With plug cap : 7.6±10%KΩ
		Without plug cap : 3.1±10%KΩ
Ignition timing	“F” Mark	Before TDC 13° / 1700 rpm
	Timing advanced character	Before TDC 28° / 4000 rpm
		Before TDC 27° / 8000 rpm
Pulse generator resistance (20 )		50~200Ω
Exciting coil resistance (20 )		400~800Ω
Ignition coil-primary max. voltage		95~400 V
Pulse generator voltage		1.7 V above
Exciting coil voltage		95~400 V

### Starting System

Item		Specification
Starting motor	type	DC TYPE
	capacity	0.5 KW

**TROUBLE DIAGNOSIS****Charging System****No power supply**

- Dead battery
- Disconnect battery cable
- Fuse burned out
- Faulty ignition switch

**Low voltage**

- Weak battery
- Loose battery connection
- Charging system failure
- Voltage-current regulator failure

**Intermittent power supply**

- Loosen wire connector in charging system
- Loose battery cables
- Loose charging system connection
- Loose connection in lighting system

**Charging system failure**

- burn Fuse
- Loose, broken or shorted wire or wire connection
- Faulty voltage-current regulator
- Faulty alternator

**Starting System****Starter motor does not work**

- The fuse is blown
- The battery is not fully charge
- Poor main switch
- Poor starter switch
- The front and rear brake switches do not operate correctly
- Starter magnetic switch is out of work
- The ignition coil is poorly connected, open or short-circuited
- The starter motor is out of work

**Ignition System****No spark produced by spark plug**

- The spark plug is out of work
- The cable is poorly connected, open or short-circuited
  - Between alternator and C.D.I.
  - Between CDI and ignition coil.
  - Between CDI and main switch
- Poor main switch
- Poor C.D.I.
- alternator is out of work

**Engine does not crank smoothly**

- Primary coil circuit
  - Poor ignition coil
  - Poor connection of cable and connectors
  - Poor main switch
- Secondary coil circuit
  - Poor ignition coil
  - Poor spark plug
  - Poor high-tension cable
  - Current leakage in the spark plug cap
- Incorrect ignition timing
  - Poor alternator
  - Improper installation of the pulse sensor
  - Poor C.D.I.

**Weak starter motor**

- Poor charging system
- The battery is not fully charged
- Poor connection in the windings
- The motor gear is jammed by foreign material

**Starter motor is working, but engine does not crank**

- Poor starter motor pinion
- Poor starter clutch
- The starter motor run in reverse direction
- Poor battery

**CHARGING SYSTEM**

**Charging wire diagram**

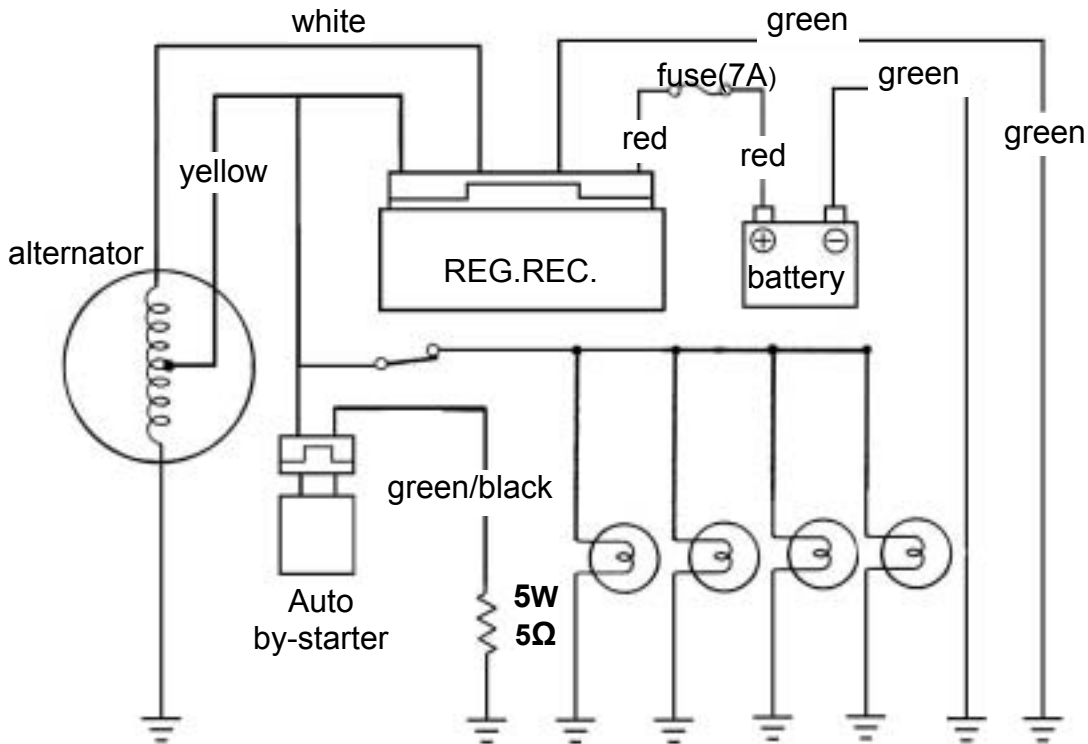

**Current Leakage Inspection**

Turn the main switch to OFF position, and remove the negative cable terminal (-) from the battery.

Connect an ammeter between the negative cable terminal and the battery negative terminal (as shown on left diagram).

**⚠ Caution**

- In the current leakage test, set the current range at larger scale, then gradually decrease to the lower scale as the test process goes to avoid possible damage to the ammeter and the fuse.
- Do not turn the main switch to "ON" position during test.

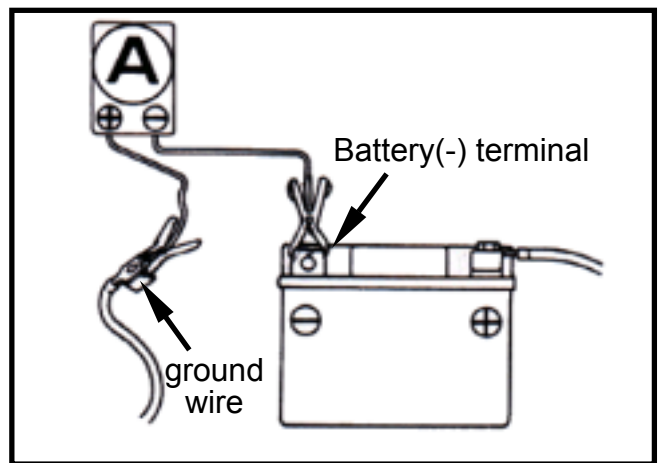

If the leaked current exceeds the specified value, it may indicate a short circuit.

**Allowable current leakage: Less than 1 mA.**

Disconnect each cable one by one and take measurement of the current of each cable to locate the short circuit.

## Battery

### Removal

Remove the 4 screws on the battery cover.  
(Screws x 4).

### CAUTION

- Electrolyte (diluted sulfuric acid) is very toxic. Once it spreading on clothes, skin, or eyes, it will cause burned or blind. In case of being spread, flush with great quantity of water immediately, and then send to hospital.
- When clothes is spread by electrolyte, it will contact with skin. So, it must flush with great quantity water to take off the clothes.

Remove the battery cover.

Disconnect the negative (-) cable from the battery first, then the positive (+) cable.  
Remove the battery.

Install the battery in reverse order of removal.

### CAUTION

- To prevent form circuit short, connect positive(+) terminal at first, and next negative (-) terminal.

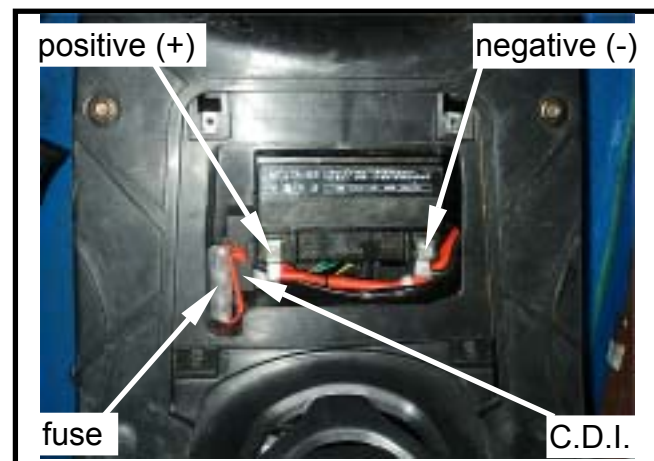
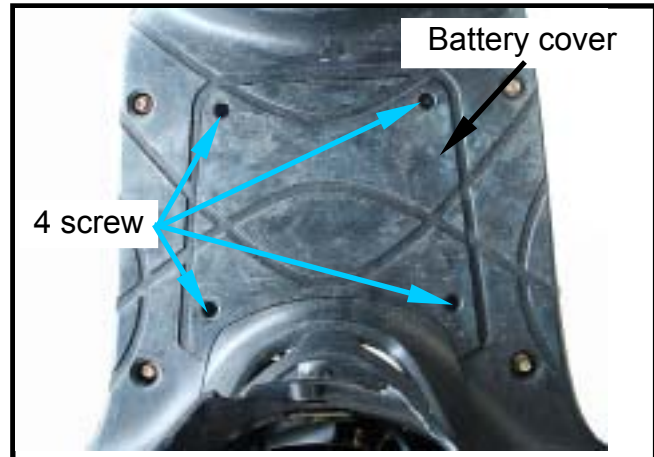

### Voltage Check

With a digital voltage meter or multi-meter to measure battery voltage.

#### Voltage:

**Fully charged:** 13.0 – 13.2V (at 20 )

**Undercharged:** Below 12.3 V (at 20 )

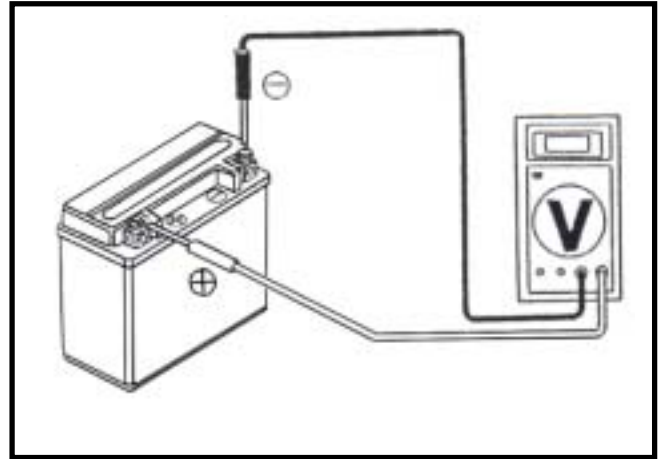

### CHARGING

Connect the Charger positive (+) to the battery positive (+) terminal.

Connect the Charger negative (-) to the battery negative (-) terminal.

	Standard	Max.
Charging current	0.6A	6.0A
Charging time	5~10H	1H

#### Warning

- Strictly keep flames away from a charging battery.
- The charging "ON"/ "OFF" is controlled by the charger's switch. Do not control the charging by battery jump wires.
- Turn the charger's switch "OFF" at first before or after charging to prevent from sparks created on the connectors and explosion.
- To charge a battery must be based on the battery's ampere-hour showed on label.

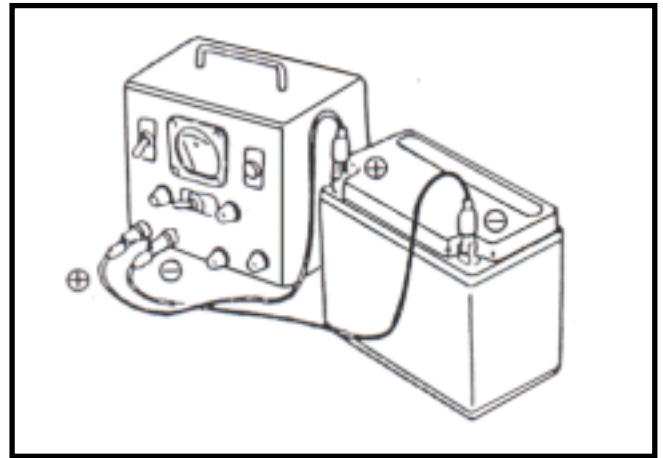

#### CAUTION

- Quick charge a battery should be used only in an emergency.
- Make sure the current and charging time of above description.
- The battery will be damaged by too much current or too rush charging.
- When finishing charge, it is necessary to measure voltage after 30 minutes.

After installing the battery, coat the terminals with clean grease.

## Charging Voltage/Current Inspection

### ⚠ Caution

- Before conducting the inspection, be sure that the battery is fully charged. Use a fully charged battery having a voltage larger than 13.0 V. If undercharged, the current changes dramatically.
- While starting the engine, the starter motor draws large amount of current from the battery. Thus, do not start the engine with battery.

After the engine is warmed up, replace original battery with a fully charged battery. Connect a digital voltmeter to the battery terminals.

Connect an ammeter between both ends of the main fuse.

### ⚠ Caution

When the probe is reversibly connected, use a voltmeter having an indication that the current flows from the positive or the negative direction and the measurement should be at zero, ammeter at one direction only.

### ⚠ Caution

- Do not use short-circuit cable.
- It is possible to measure the current by connecting an ammeter between the battery positive terminal and the cable position terminal, however, while the starter motor is activated, the surge current of the motor draws from the battery may damage the ammeter. Use the kick lever to start the engine.
- The main switch shall be turned to OFF position during the process of inspection. Never tamper with the ammeter and the cable while there is current flowing through. It may damage the ammeter.

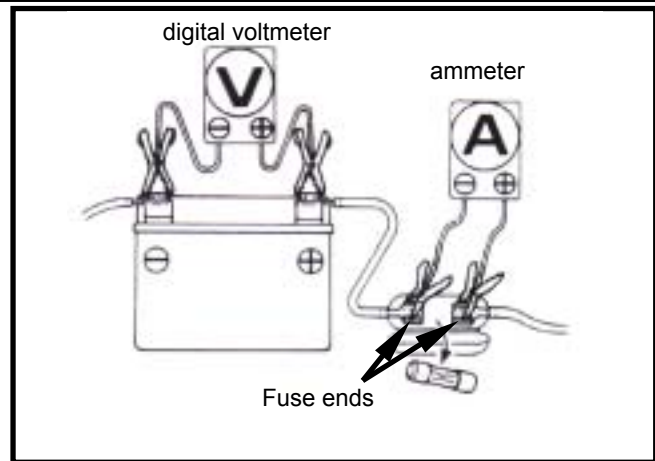

Turn on the headlight to high beam and start the engine.

Accelerate the engine gradually to the specified revolution per minute and measure the charging voltage/current.

### Specified Charging Current:

- |                 |                          |
|-----------------|--------------------------|
| (headlight OFF) | 0.6 A or more/2500rpm    |
|                 | 1.2 A or more / 6000 rpm |
| (headlight ON)  | 0.4 A or more/2500rpm    |
|                 | 1.0 A or more / 6000 rpm |

### Control Charging Voltage:

14.0±0.5 V / 2000 rpm

### ⚠ Caution

To replace the old battery, use a new battery with the same current and voltage.

The following problems are related to the charging system, follow the instructions provided in the checking list to correct it if any one of the problems takes place.

- (1) The charging voltage can not exceed the voltage between two battery terminals and the charging current is in the discharging direction.
- (2) The charging voltage and current are too much higher than the standard values.

The following problems are not related to the charging system; correct it if any by following steps indicate in the checking list.

- (1) The standard charging voltage and current can only reach when the revolution of the engine exceeds the specified rpm.
  - Bulbs used exceed their rate and consume too much power.
  - The replacement battery is aged and does not have enough capacity.
- (2) The charging voltage is normal, but the current is not.
  - The replacement battery is aged and does not have enough capacity.
  - Battery used do not have enough electricity or is over charged.
  - The fuse of the ammeter is blown.
  - The ammeter is improperly connected.
- (3) The charging current is normal, but the voltage is not.
  - The fuse of the voltmeter is blown.

**VOLTAGE REGULATOR INSPECTION**

Remove the front cover. (screws x 3 x 2).  
 Remove the front cover mounting screw(screws x 1)and remove the headlight wiring connector.  
 Disconnect the 4P connector on the diode, and check the continuity between main wire terminals according to following method.

**Main wire circuit inspection**

Item (wire color)	Judgment
Check voltage between battery terminal (red) and ground (green).	Battery voltage
Check continuity between ground(green) and frame.	Continuity
Check illumination wire (yellow) to ground. (disconnect the connector of the resistor's pin and automatic by-starter pin. Illumination switch is in OFF)	Continuity & resistance
Check charging coil (white) to ground)	Continuity & resistance

If the measured value is abnormal, check the abnormal wire circuit. If components are good, it could be a poor wire circuit.  
 If all items are in good condition, then replace the voltage regulator.  
 If main wire circuit check is in normal and there is no loose in the pins of voltage regulator connector, then measure the resistance between the connector of voltage regulator.

**Voltage Regulator Check** Unit: Ω

Multi-meter(+)	Red (R)	White (W)	Yellow (Y)	Green (G)
Multi-meter				
Red (R)				
White (W)			0.04~0.06	160~180
Yellow (Y)		0.04~0.06		160~180
Green (G)		160~180	160~180	

If the resistance values are abnormal among the pins, replace the voltage regulator.

**⚠ Caution**

- Do not touch the probe of multi-meter by fingers, then the resistance values will be incorrect because there is some resistance existence in human body.
- To use the multi-meter recommended by SYM. Otherwise, the measured resistance might be different.

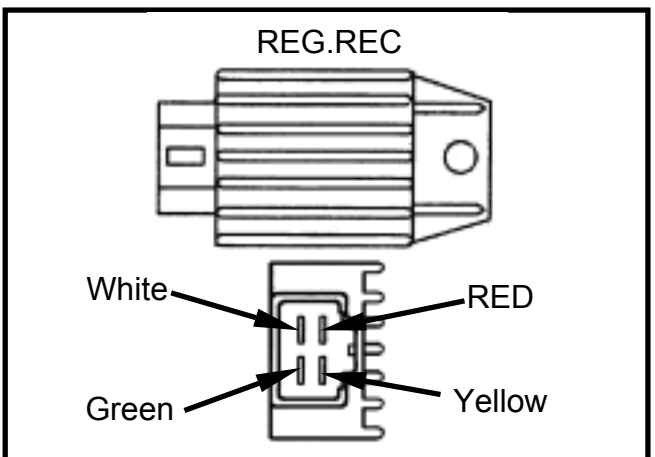
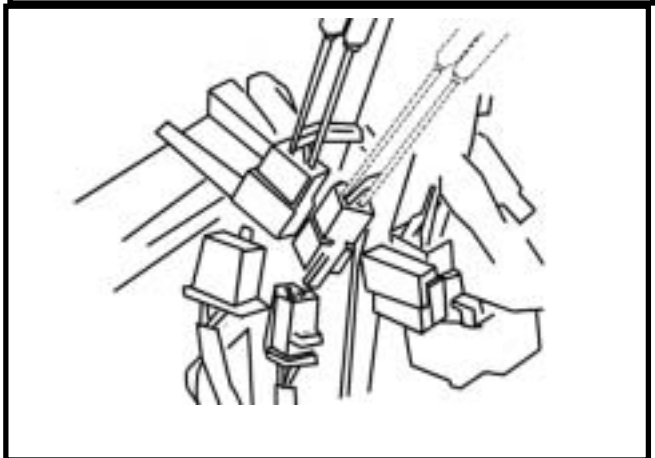



## Alternator charging coil

### Caution

The check of alternator charging coil and illumination coil can be done when the alternator is mounted on engine.

### Check

Remove the 3P connector of the alternator. Measure the resistance between the white wire on the alternator and frame ground with a multi-meter.

**Standard:  $0.6 \pm 0.1$  (20 )**

Replace the alternator charging coil if the measured value exceeds standard.

## Alternator lighting coil

### Check

Remove the 3P connector of the alternator. Measure the resistance between the yellow wire on the alternator and frame ground by multi-meter.

**Standard:  $0.8 \pm 0.1$  (20 )**

Replace the alternator lighting coil if the measured value exceeds standard.

## Resistor check

Remove the front cover.

Measure the resistance between the resistor wire (green/black) and frame ground.

**Standard: 5 /5W: 4.5~5.5(green/black)**

**Standard: 7.5 /30W: 7.0~8.0(pink)**

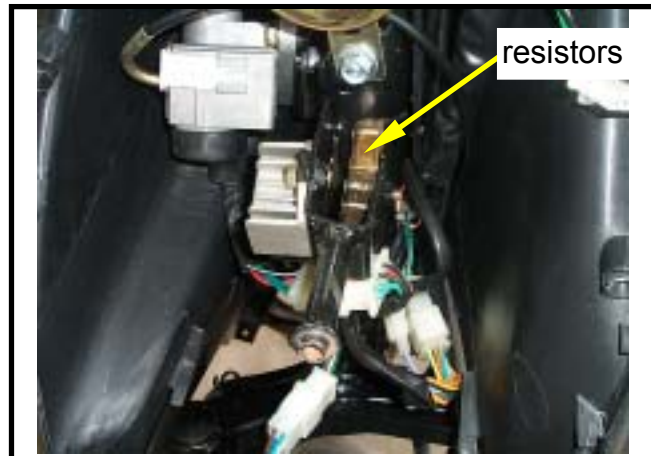
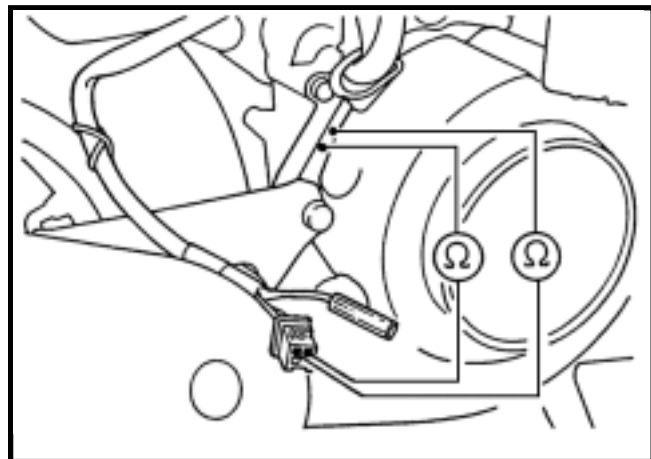
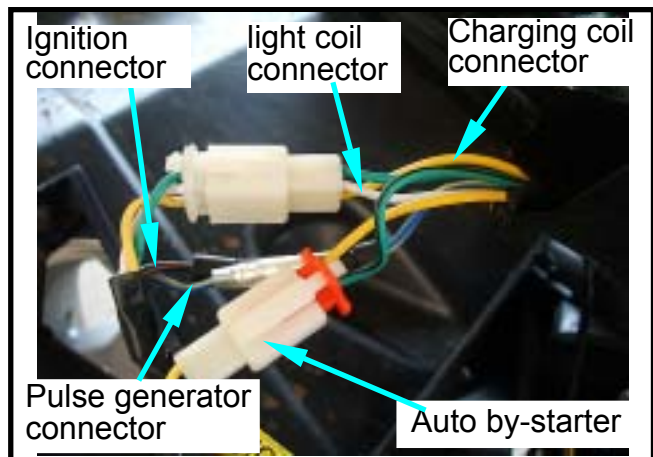

**IGNITION SYSTEM**

**Ignition System Circuit**

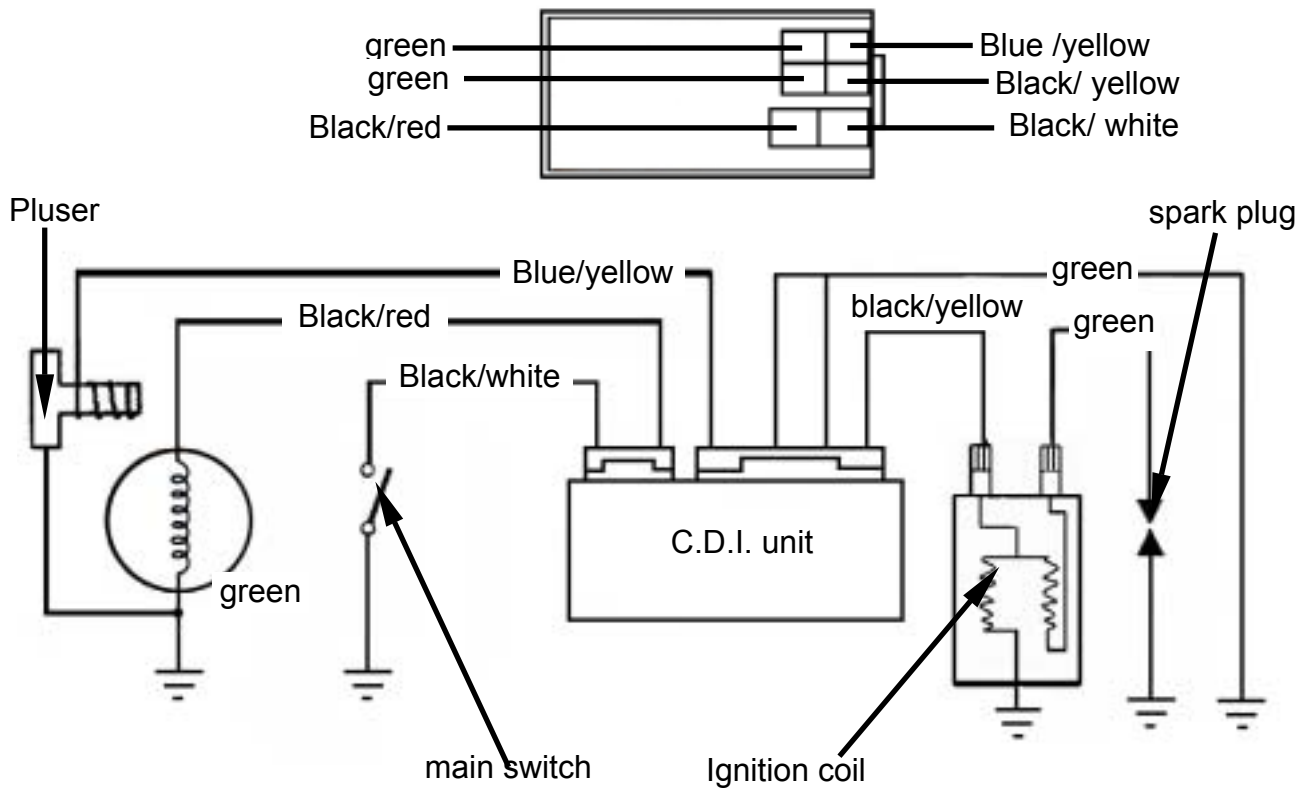

**CDI UNIT**

**Removal**

Remove the right body cover, then the C.D.I. unit can be removed from the frame.

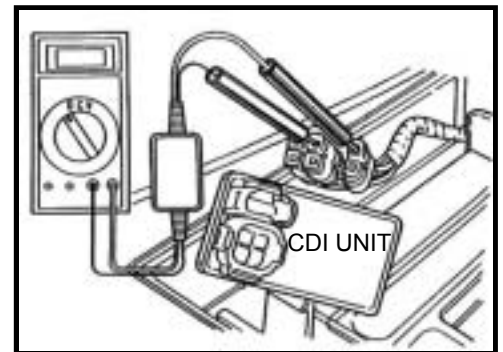

**Check**

Disconnect the connector from the CDI unit.

Make the following inspection at each terminal of the harness side connector.

ITEM		Measure at:	Standard (at 20C)
Pulse Generator		Blue/Yellow-green	50 ~200Ω
Ignition Coil	Primary	Black/yellow-green	0.21Ω±10%
	Secondary	Green-high voltage cable -w/o cap	3~5KΩ
		Green-high voltage cable - w/ cap	7~12KΩ

## Ignition coil

### Removal

Remove the luggage box, center cover.  
 Remove spark plug cap.  
 Remove the primary coil wire of ignition coil.  
 Remove the fix bolts for the ignition coil, and remove the ignition coil.  
 Install the ignition coil in reverse order of removal.

### ⚠ Caution

Install primary coil with black/yellow lead connected to black connector and green lead connected to green connector.

### Spark plug confirmation

Remove the spark plug and install a good plug into plug cap, and then ground it to engine ground.  
 Make sure its spark condition. If it is in not good or burnt spark plug, replace the spark plug with new one.

### ⚠ Caution

- Make sure each wire connection is correct, and test as required. Even the wire connection is in correct, sometimes, it might not be tested occurred.

Connect the high voltage shunt with a multi-meter or input a resistor in the 10M 100V of voltage meter.  
 Connect ignition coil wires, and connect a shunt between primary terminal (black/yellow and green) and frame ground.  
 Press the starting motor button, or starting lever to test the max. primary voltage of ignition coil.  
 Connection: connect (+) terminal to green side, and (-) to black/yellow side.

**Min. voltage: Above 95 V.**

### ⚠ Caution

Do not touch metal parts on the test probe with fingers to avoid electric shock.

### Primary coil check

Disconnect the primary coil connector and check the resistance between primary coil terminals.

**Standard: 0.21 ±10% (at 20 )**

Primary coil is good if resistance within standard.

Primary coil is broken if resistance is infinite.  
 Replace the coil.

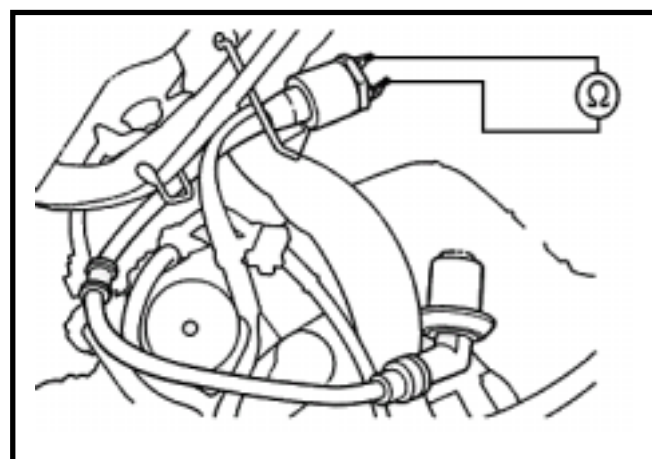
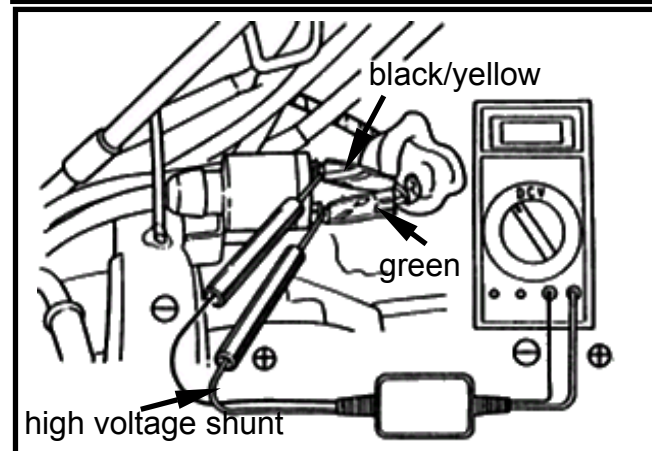
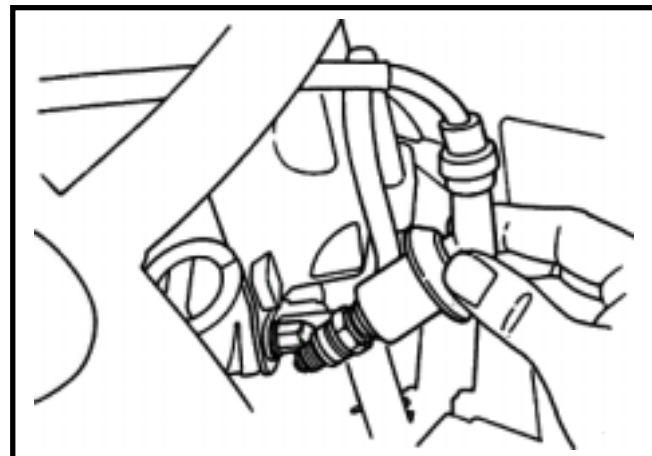
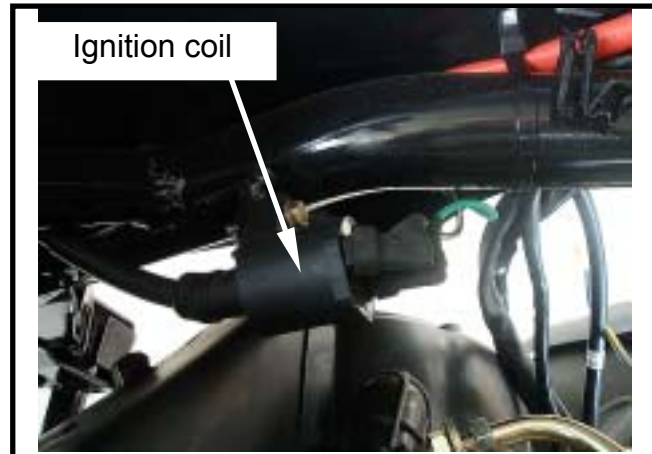

**Secondary coil**

Attached the spark plug cap, measure the resistance between plug cap side and green terminal.

**Standard value: 7-12 k (20 )**

Remove the spark plug cap, measure the resistance between plug cap side and green terminal.

**Standard value: 3-5 k (20 )**

Secondary coil is good if resistance within standard.

Secondary coil is broken if resistance is infinite. If the spark plug cap attached and the measured value is exceed standard value, it means the spark plug cap is in not good.

**Replacement**

Remove the ignition coil bolt to replace the ignition coil if necessary.

**Pulse generator****Caution**

Checking pulse generator can be done on engine. But, the spark plug must be installed onto the cylinder head, and cylinder compression pressure must be in normal condition.

**Check**

Remove body cover.

Remove the pulse generator connector.

Measure the resistance between blue/yellow terminal on engine side and frame ground.

**Standard: 140 ± 20 (20 )**

Replace the alternator if the measured value exceeds standard value.

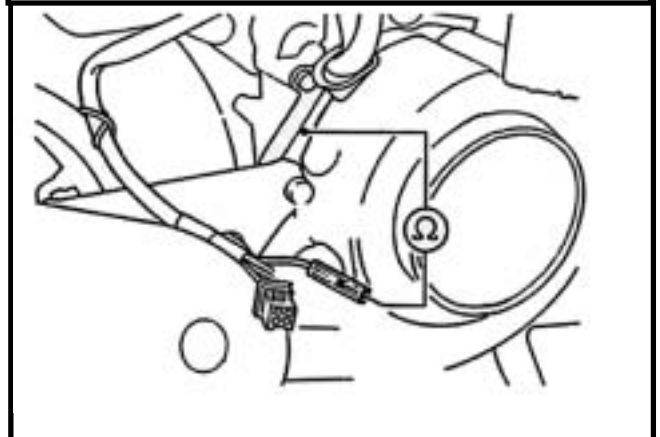
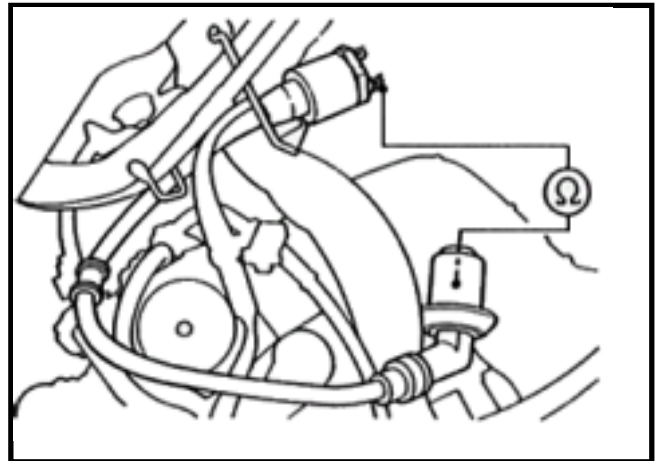

## STARTING SYSTEM

### Starting Circuit

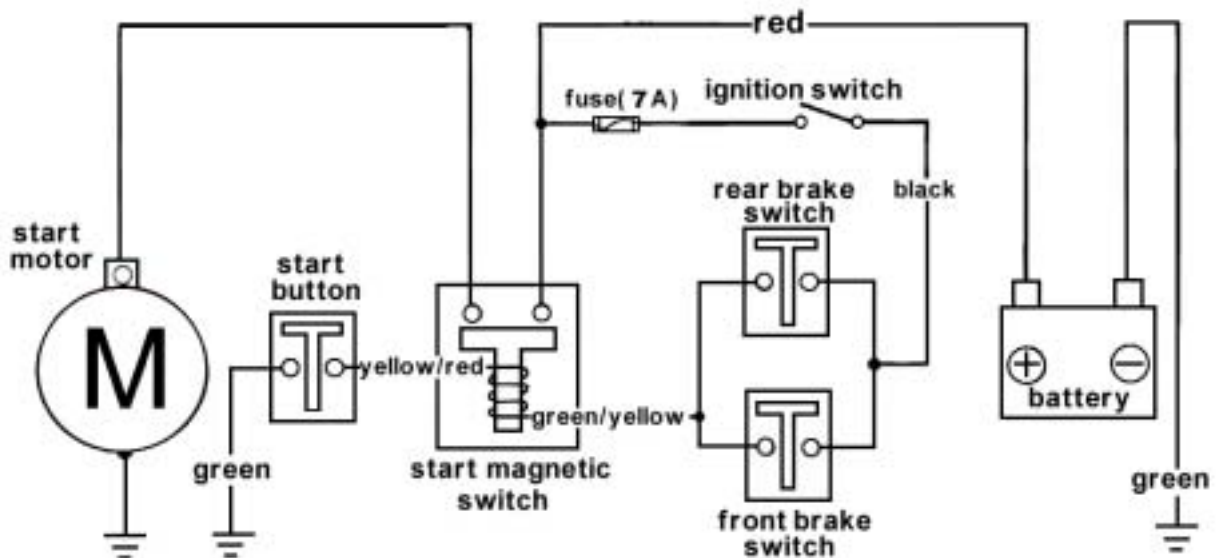

#### Starter magnetic switch inspection

Turn main switch to "on", and operate the brake lever. Then press starting button to check if there a click sound. It is normal if there is a click sound.

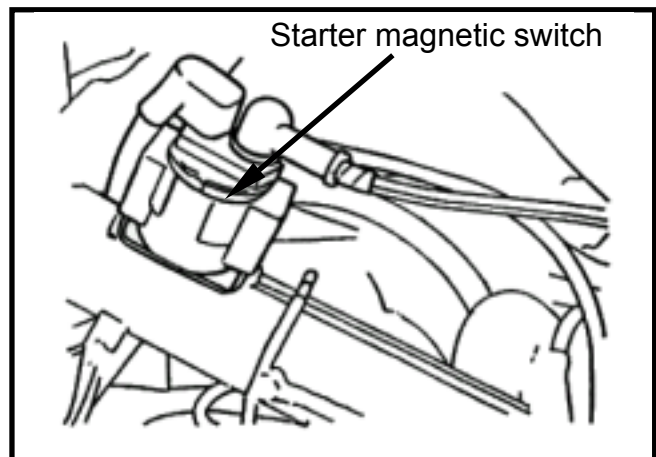

Remove the luggage box.  
 Disconnect the battery negative (-) terminal.  
 Remove the battery positive (+) connection and starting motor wires from the starter magnetic switch large pin.  
 Remove the power control connector of the Starter magnetic switch.  
 Connect a Ohmmeter between the Starter magnetic switch large pins.  
 Connect the green/yellow wire to battery positive (+) terminal, and yellow/red to battery negative (-) terminal.  
 Check the continuity between the Starter magnetic switch large pins. If it is not continuity, then replace the starter magnetic switch.

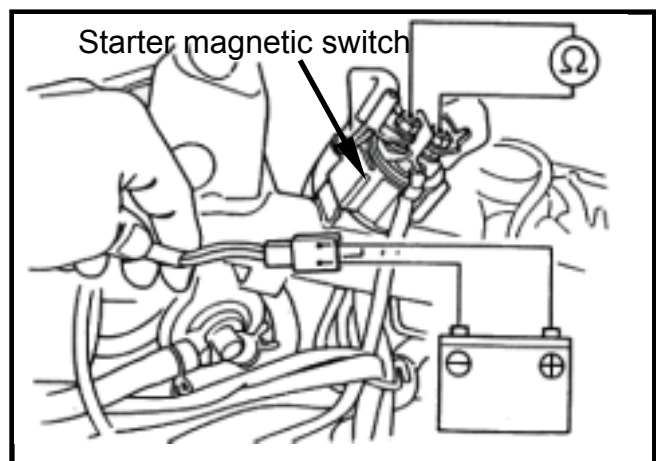

**Starting Motor Removal**

Remove the right side cover. (screws x3)  
Firstly, remove the battery negative (-) terminal, and then remove the positive (+) terminal.  
Remove the luggage box.  
Remove the starting motor power wire.  
Remove the starting motor mounting bolts and motor.

**Starting Motor Installation**

Install the motor in reverse order of removal.

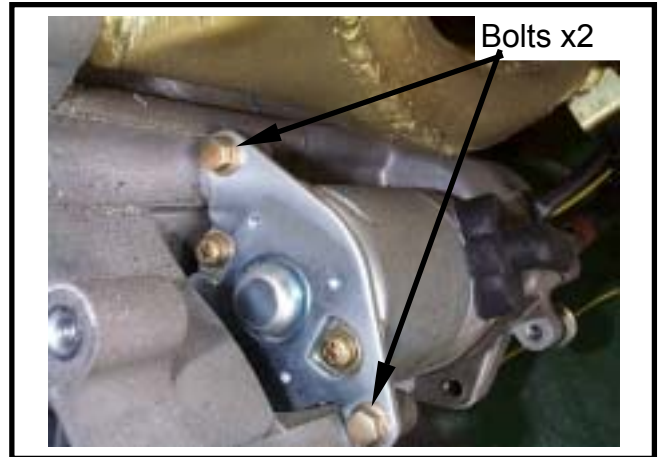

**METER**

**Removal**

Remove the front handle cover.

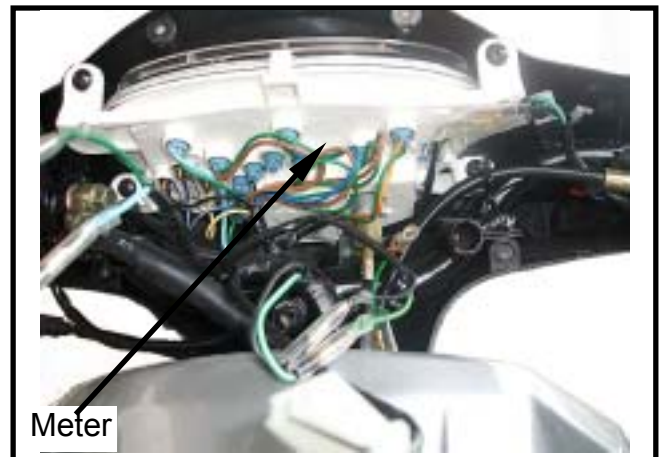

Remove the speedometer cable.

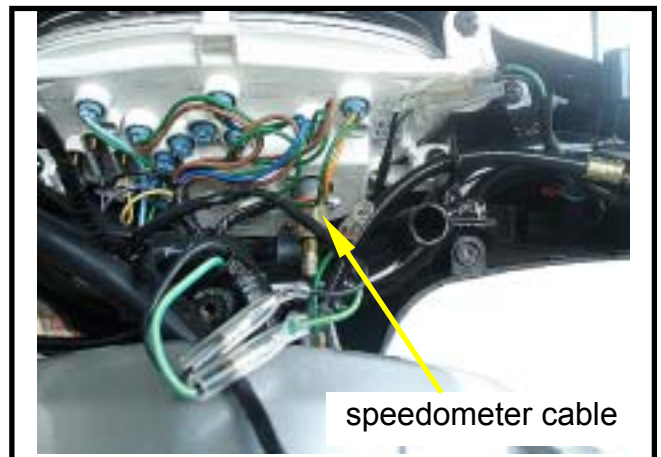

Remove the front cover.  
Remove the power connector of the meter.

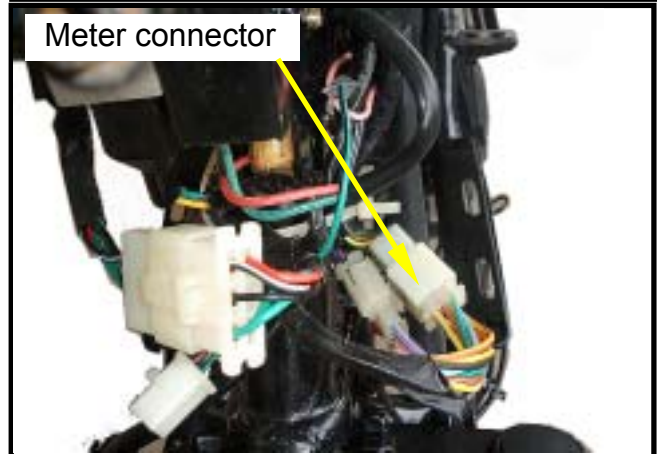

## 16. ELECTRICAL EQUIPMENT



Remove the rear handle cover.  
Remove the meter mounting screws.  
Take out the meter.

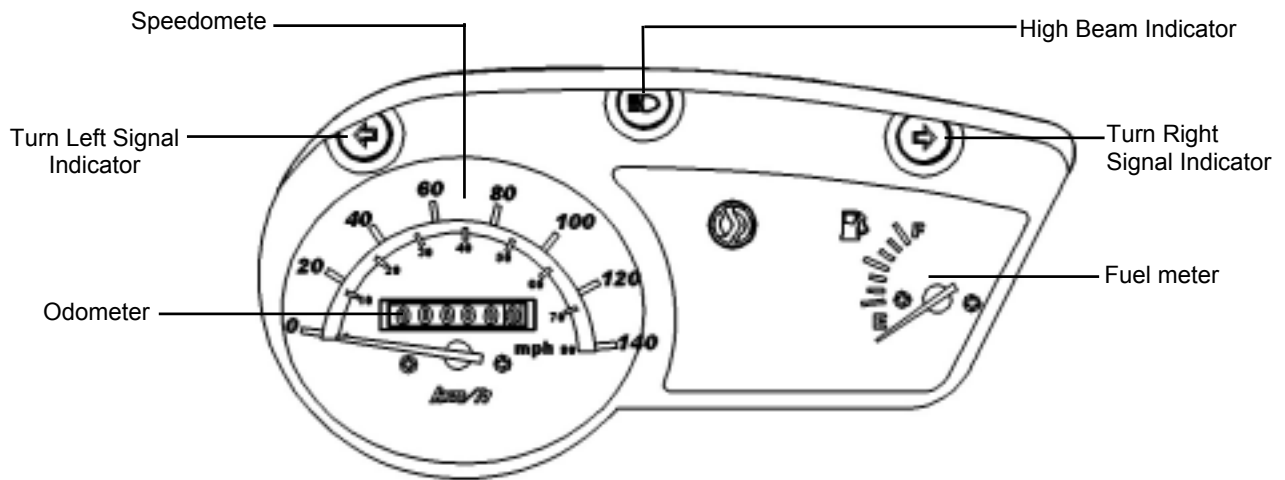
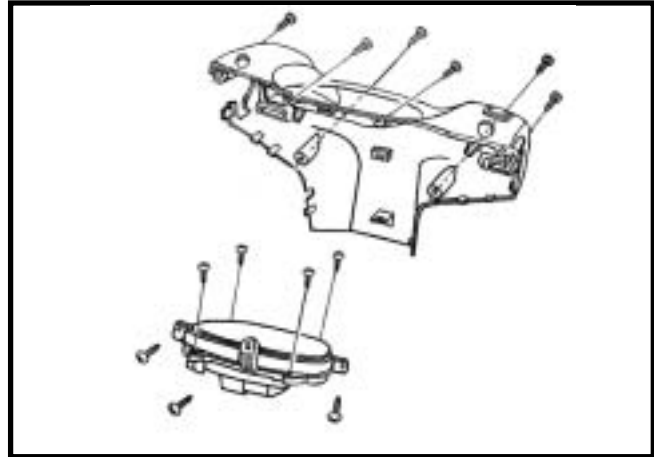

### Caution

Do not wipe the meter or headlight with organic solvent such as gasoline to prevent from damage these components.

### Installation

Install the meter in reverse order of removal.

**LIGHT/BULBS****Headlight Bulb Replacement**

Rear the screw of the front cover.

Rear the front cover.

Disconnect the headlight wire connector.

Press down the bulb spring locker and then

remove the locker with turning it left motion.

Remove the bulb.

Replace the bulb with new one if necessary.

(12V 35W/35W)

**Caution**

- Do not touch the bulb surface with fingers because the bulb will create hot-spot so that let it be burnt. It has to be package with cloth or wear glove as installing.
- Wipe the bulb with cloth to prevent from damaged if the bulb be touched by hands.

Install the bulb in reverse order of removal.  
Turn the main switch ON/OFF to check if the bulb has been installed properly after installation.



Please conduct the headlight beam adjustment job if replace the headlight bulb.

**The headlight beam adjustment**

Loosen the adjustment bolt located under the headlight.

**Caution**

- This outer cover of headlight is a fixed type so that the light seat will be moved only when adjusting.





## 16. ELECTRICAL EQUIPMENT



### Front Turn Signal Lamp Bulb Replacement

Remove the front handle cover.  
Remove the wire connector of the turn signal light.

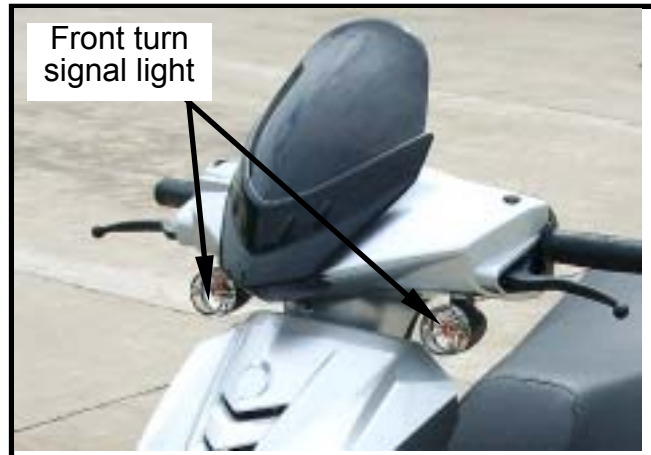

Pull out the bulb and replace it with new one.  
(12V 5W)

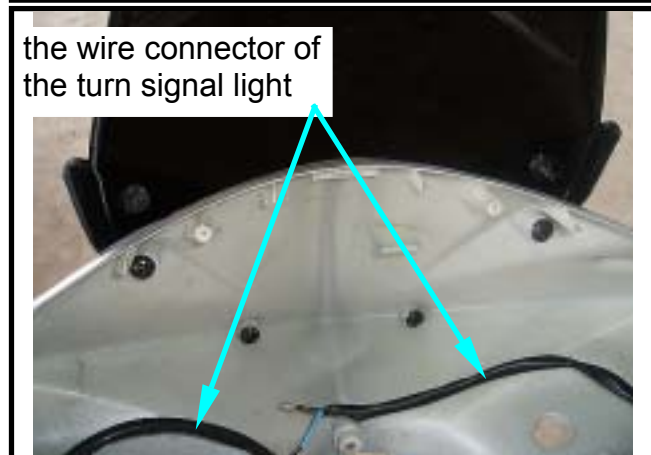

### Installation

Install the bulb in reverse order of removal.

### Bulbs Replacement of tail light/brake light/rear turn signal light.

Remove the seat and luggage box .(Bolts x4)  
Remove the rear carrier.(Bolts x3)  
Remove the rear center cover.  
Remove the 2 bolts of the rear fender.

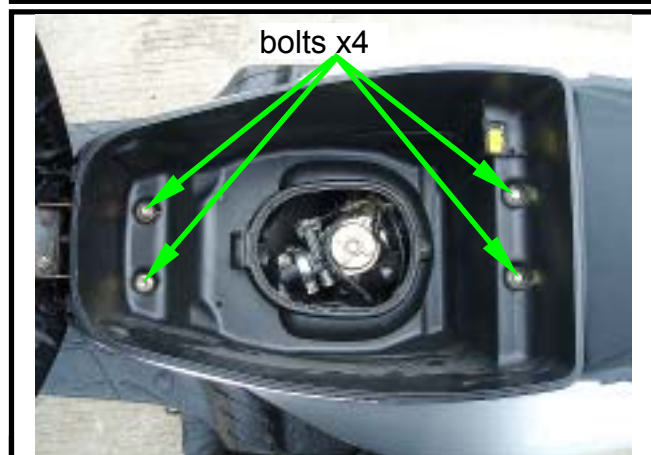

Remove the tail light assembly.



Replace the bulbs of the tail light, brake light (12V 5W/21W)  
 Replace the bulbs of the turn signal light (12V/10W).

**Installation**

Install the bulb in reverse order of removal.



**MAIN SWITCH/HORN**

**Main Switch**

**Check**

Remove the headlight connector and the front cover.

Disconnect main switch leads connector.

Check connector terminals for continuity.

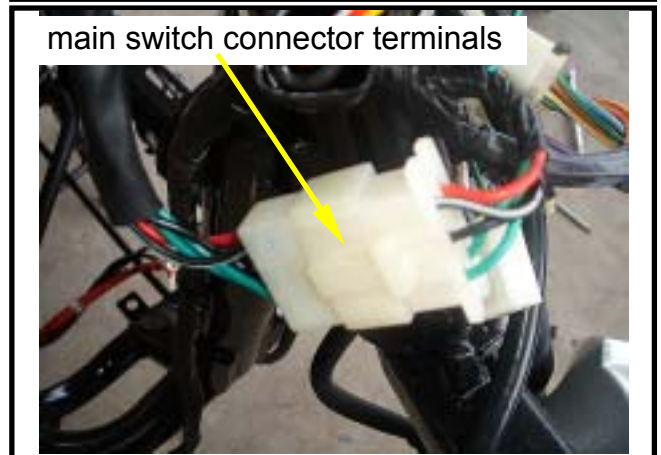

color Location	Black	Black/ white	Red	Green	Green
<b>LOCK</b>		—————			
<b>OFF</b>		—————			
<b>ON</b>	—————				

**Replacement**

Remove the main switch connector and fixing bolts (bolts x 2)

Remove the main switch.

Install a new main switch and tighten the bolts. (bolts x2)

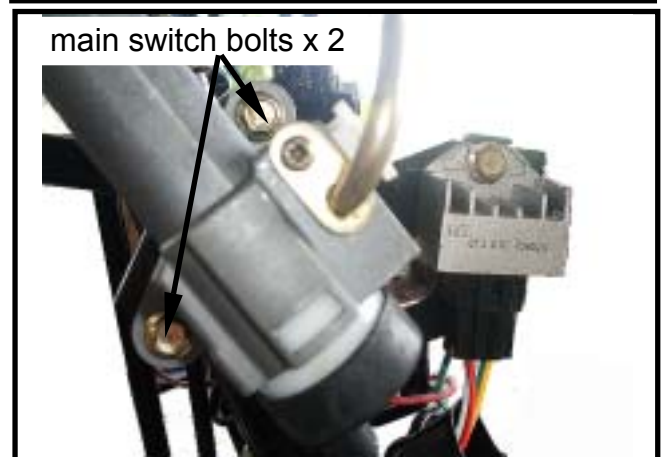

# 16. ELECTRICAL EQUIPMENT



## Handle switch

Remove the front handle cover.  
 Disconnect the connector of the handle switch.  
 Check the continuity of follow pins listed below columns.

### Headlight switch

color \ Location	Brown	Yellow	Pink	Brown /White	Yellow
		—			
	—				
	—			—	

### Starting switch

color \ Location	Yellow/red	green
FREE		
	—	—

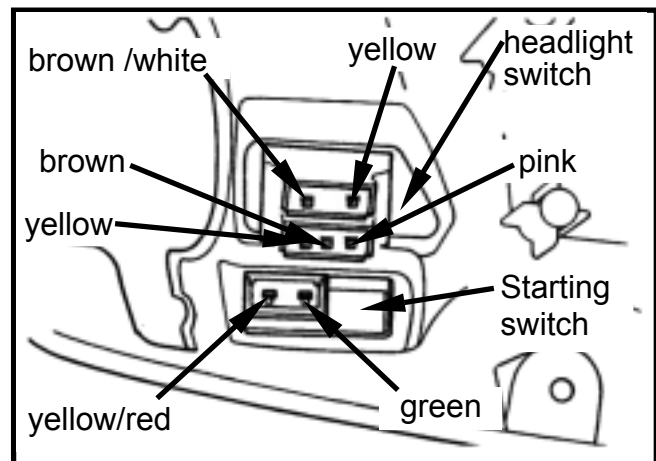
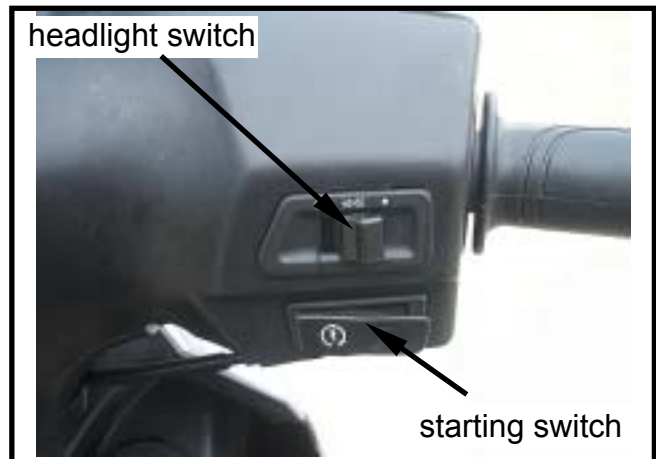

### High/Low beam switch/ seat open

color \ Location	blue	white	brown/white	black	purple
	—	—			
		—			
seat open	—	—		—	

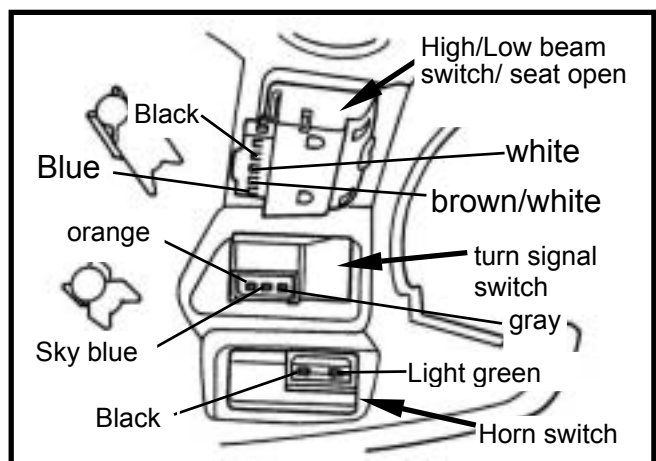
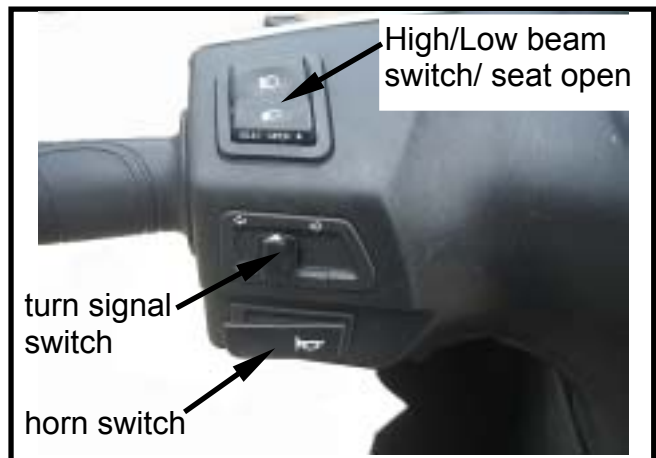

### Horn switch

color \ Location	Black	Light green
FREE		
	—	—

**Turn signal light switch**

Location		color	Sky blue	Gray	orange
➔			—	—	
N	FROM R		—		
	PUSH OFF				
	FROM L			—	
➔				—	

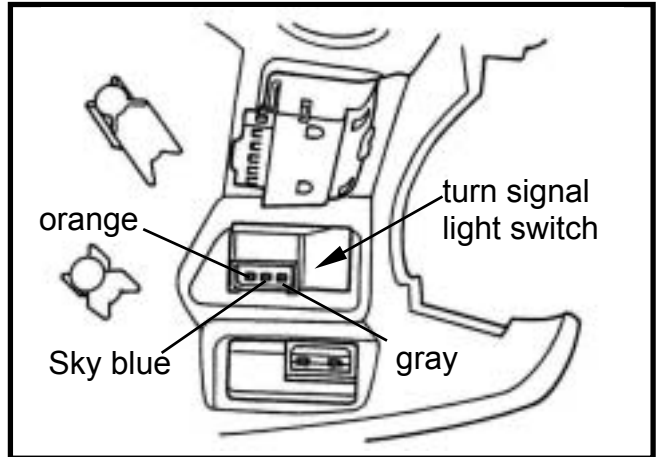

**Brake light switch**

The circuit of black wire and the green/yellow wire on the brake light switch should be in continuity when operating the brake lever. If the switch damaged, replace it with new one.

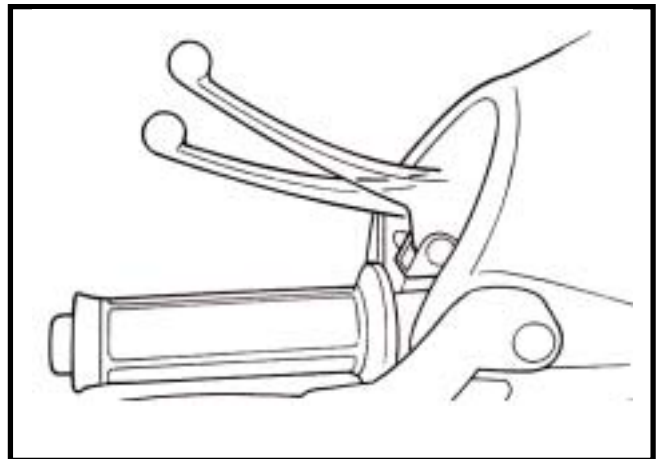

**Horn**

Remove the front cover. Connect the light blue wire on the horn to the battery positive (+) terminal, and the green wire to the battery negative (-) terminal. Then, the horn should sound. Replace it if necessary.

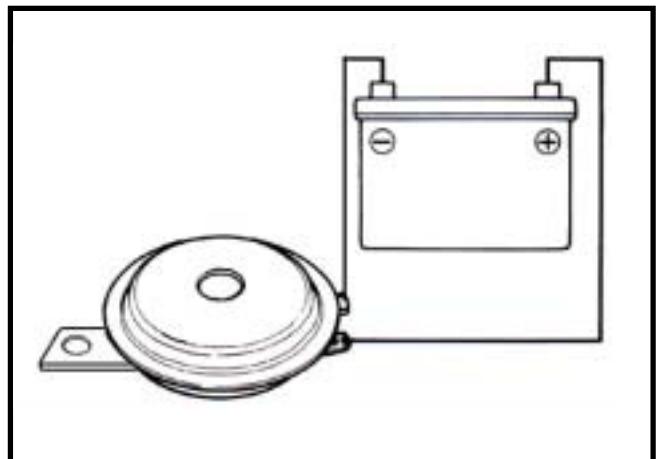

## 16. ELECTRICAL EQUIPMENT



### FUEL UNIT

- Open the seat.
- Remove the luggage box(bolts x 4) .
- Remove the R.R. carrier(bolts x 3) .
- Remove the R.R. center cover.
- Disconnect the fuel unit wire connector.

**⚠ Caution**

Do not damage or bend the float arm as removing.

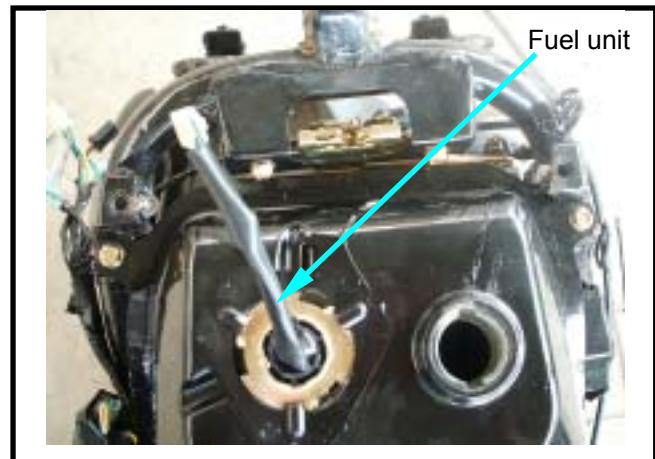

The resistance values are listed below when the float arm in “F” and “E” positions.

Float arm position	Resistance value
E(empty)	97.5~107.5Ω
F(full)	4~10Ω

DOWN(empty) Connect the fuel unit to the main harness.

- Turn the main switch “ON” position.
- Move the float arm in “UP” & “DOWN”, and then check if the fuel unit indication needle is in correct position.

**⚠ Caution**

Turn on the turn signal light to make sure battery is in good condition before this test.

Float arm position	Indicator needle
UP(full)	E(empty)
DOWN(empty)	F(full)

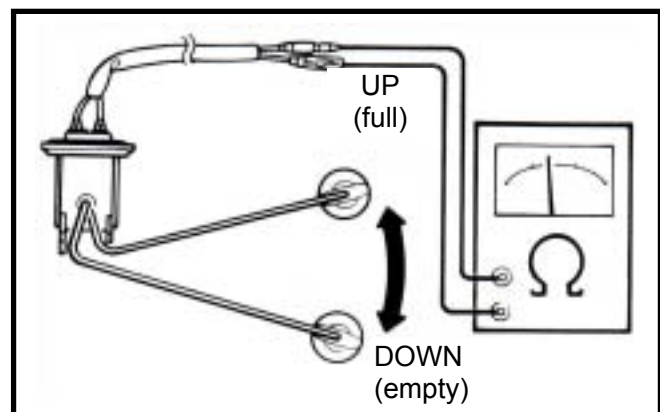

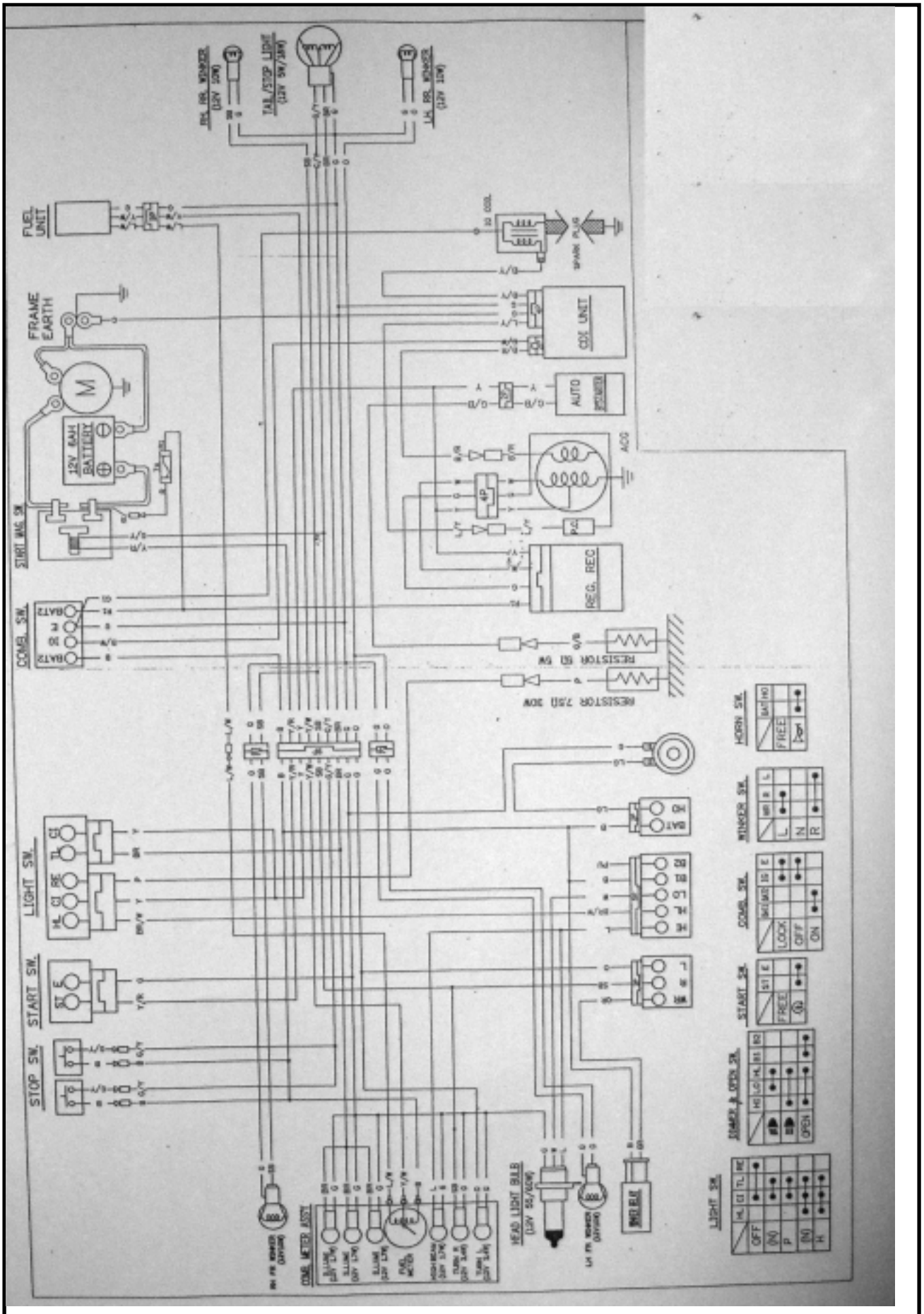



# SPECIAL TOOL



<p>ITEM: R/L CRANKCASE DISASSEMBLE TOOL NO : SYM-1120100 PURPOSE: DISASSEMBLE CRANKCASE</p>	<p>ITEM: CRANK PULLER NO : SYM-1130000 PURPOSE: INSTALL CRANKCASE</p>
	
<p>ITEM: OUTER BEARING PULLER NO : SYM-6204010 PURPOSE: REMOVE THE BEARING</p>	<p>ITEM: ACG FLYWHEEL PULLER NO : SYM-3110A00 PURPOSE: REMOVE ACG FLYWHEEL</p>
	
<p>ITEM: LOCK NUT PULLER NO : SYM-9020100 PURPOSE: REMOVE THE LOCK NUT</p>	<p>ITEM: UNIVERSAL HOLDER NO : SYM-2210100 PURPOSE: HOLD THE MDF/CLUTCH OUTER</p>
	

<b>ITEM: CLUTCHSPRING COMPRESSOR</b> <b>NO : SYM-2301000</b> <b>PURPOSE:DISASSEMBLE THE CLUTCH</b>	<b>ITEM: CLUTCH NUT WRENCH</b> <b>NO : SYM-9020200</b> <b>PURPOSE:LOOSE THE CLUTCH NUT</b>
 A black metal clutch spring compressor tool with a central vertical rod and a horizontal T-bar handle at the top. The tool has two curved arms that hold a circular spring.	 A black metal wrench with a long handle and a circular head with a hexagonal opening.
<b>ITEM: GY6 STARTER GEAR PULLER</b> <b>NO : SYM-2822100-GY6</b> <b>PURPOSE:REMOVE THE STARTER GEAR</b>	
 A set of four black metal parts for a starter gear puller. It includes a central shaft with a ball joint at the top, a top cap, and two side caps.	